













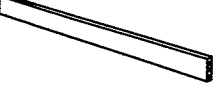

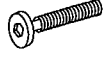
ASSEMBLY INSTRUCTION

RECTANGULAR DINING TABLE

A TABLE TOP  1 PC	B TRESTLE LEG  2 PCS	C BASE  2 PCS	D UPPER TRESTLE BAR  1 PC
E LOWER TRESTLE BAR  1 PC	F SUPPORT BAR (Unloose from step 1)  2 PCS	G ALLEN WRENCH  1 PC	H JCBC M6 x 40MM (Included 8 pcs from step 1)  24 PCS
I JCBC M6 x 80MM  14 PCS	J SPRING WASHER M6 (Included 8 pcs from step 1)  38 PCS	K FLAT WASHER M6 (Included 8 pcs from step 1)  16 PCS	L PVC DOWEL M8 x 30MM  2 PCS
M CSK SCREW M4 x 38MM  5 PCS	N WOOD BUTTON  6 PCS	O LEVELER  4 PCS	

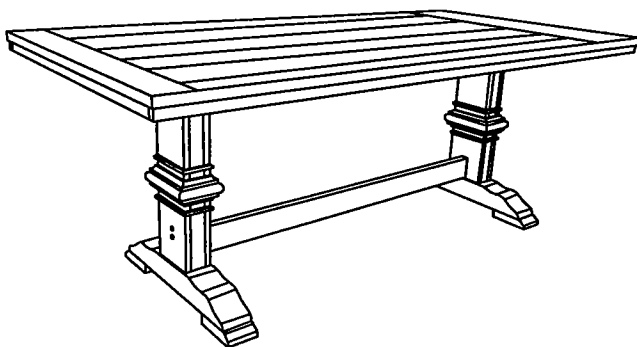

This Page lists all the contents included in the box . Please take the time to identify the hardware as well as the individual components to this product . As you unpack and prepare for assembly , place the contents on a carpeted or padded area to protect them from damage .

- 1** Please unloose 8 pcs bolt and spring washer and flat washer from the support bar(F) with Allen wrench(G). Keep the hardware for step 5 use and support bar for step 3 use.

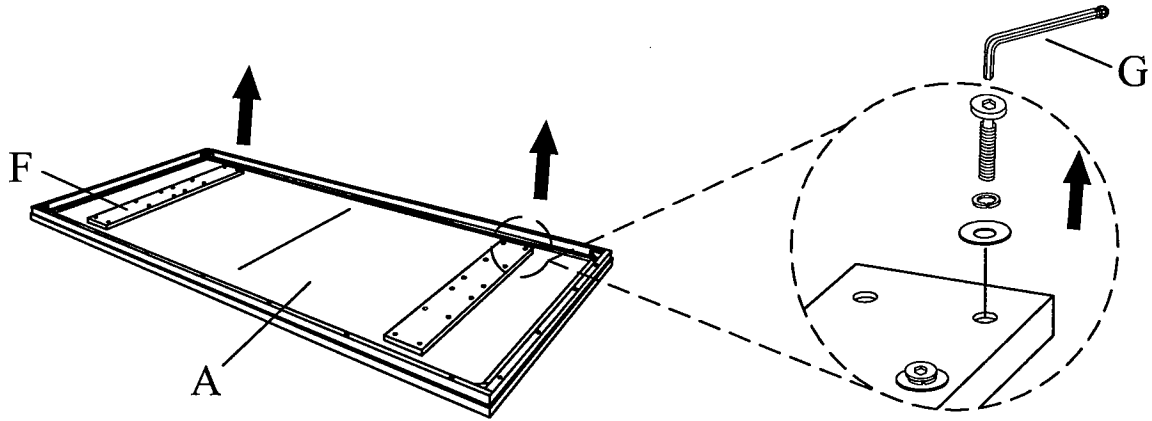

- 2** i) Insert pvc dowel(L) to both end of lower trestle bar(E).
ii) Align and fasten upper trestle bar(D) with sticker arrow as shown below and lower trestle bar(E) to trestle leg(B) using long bolt(I) and spring washer(J) and tighten with Allen wrench(G). Insert wood button(N) to cover the open hole of the leg.

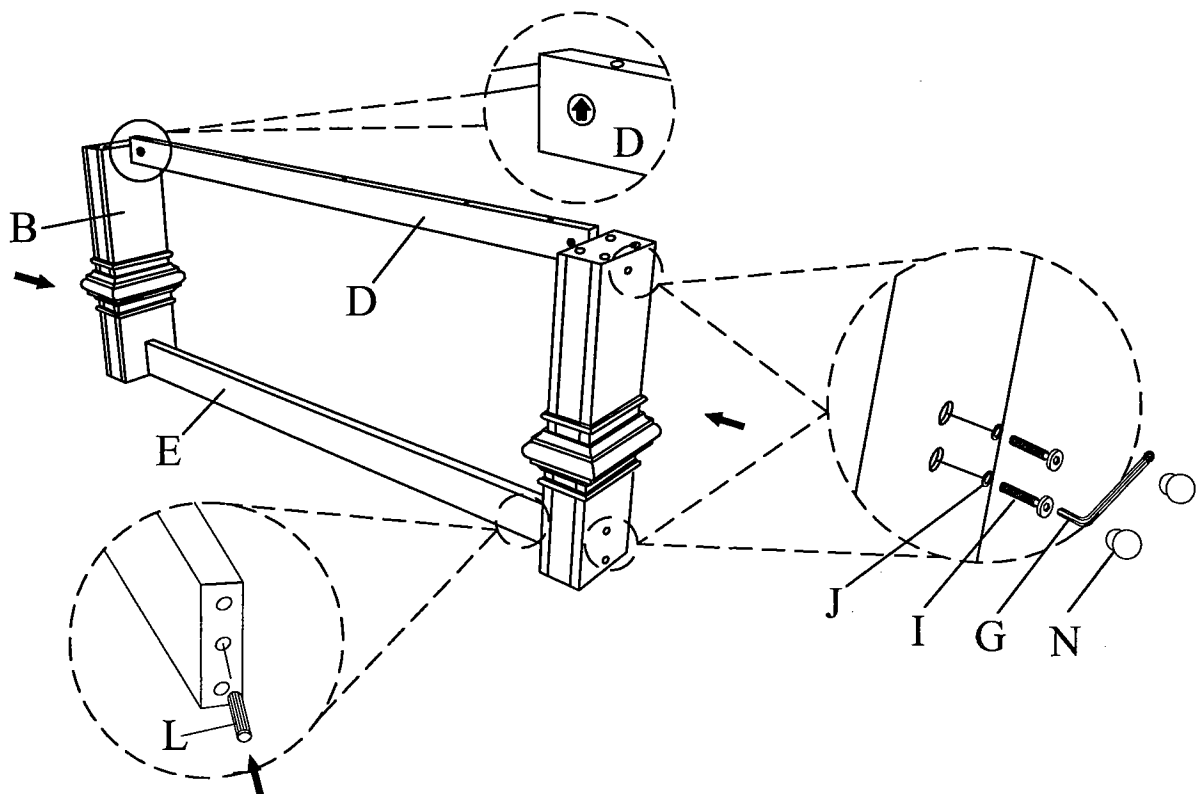

- 3** Align and fasten support bar(F) to trestle leg(B) using short bolt(H) and spring washer(J). Please follow the ARROW sticker direction as shown below.
**** Do not fully tighten the nut or bolt until all nuts and bolts are attached.**

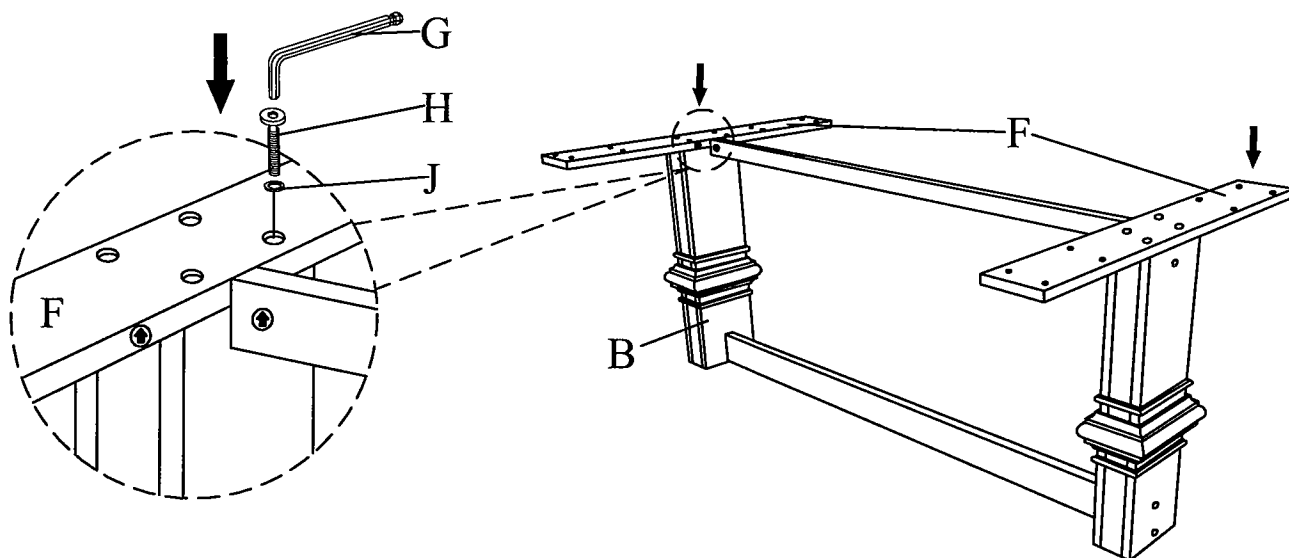

- 4** Flip table leg over, align and fasten bottom base(C) to trestle leg(B) using long bolt(I) and spring washer(J). Tighten bolts with Allen wrench(G).
Screw in the leveler(O) to bottom base.
**** Do not fully tighten the nut or bolt until all nuts and bolts are attached.**

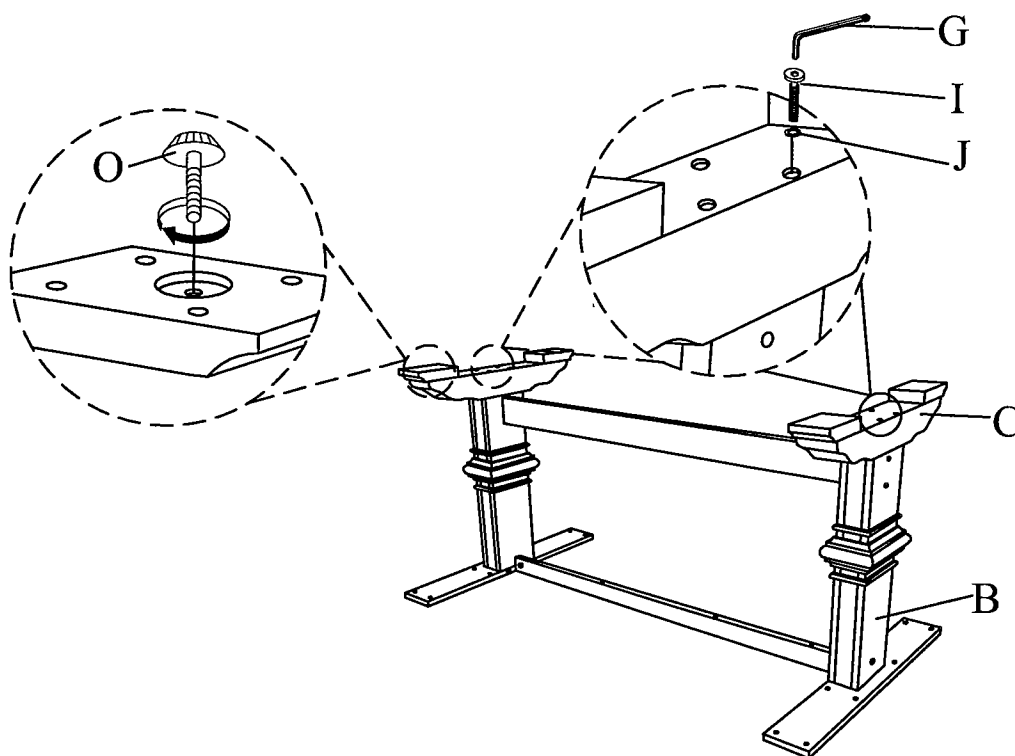

- 5** i) Place table top upside down on soft surface. Align and fasten support bar to table top using short bolt(H), spring washer(J) and flat washer(K) and fully tighten with Allen wrench(G). Which unloose from step 1 and tighten with Allen wrench(G).
- ii) Align and fasten upper trestle bar(D) to table top(A) using screw(M) and fully tighten with screw driver (Not Included).
- ** Do not fully tighten the nut or bolt until all nuts and bolts are attached.**

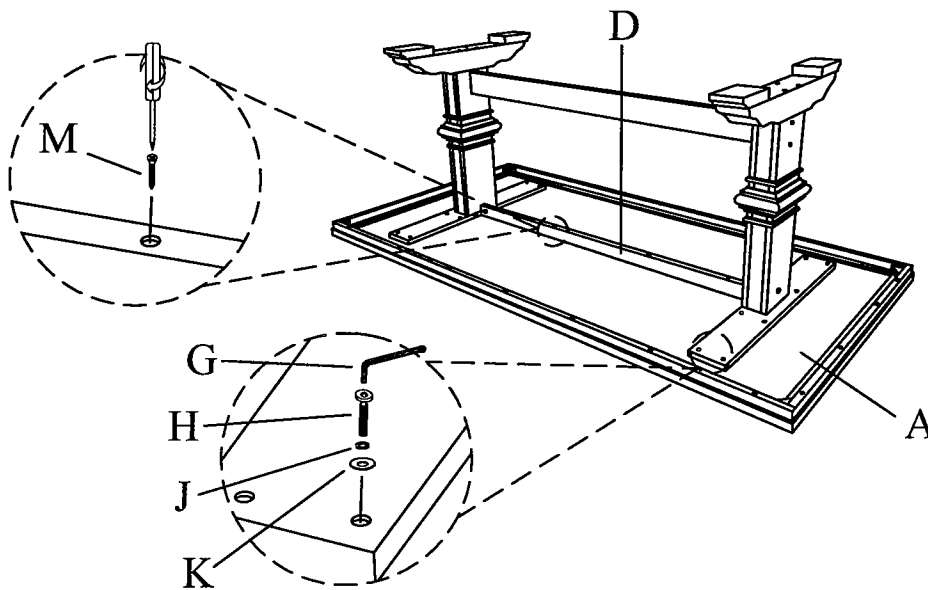

Stand table up on an even surface and check that it is balanced. If there is a slight wobble, please adjust the leveler.

Cleaning & Care

Treat Surface with care. Surface is resistant to scratches but is not scratch resistant. Clean surface with a dry or damp soft cloth. Do not use abrasive cleaners. Hardware may loosen over time. Periodically check that all connections are tight.

ASSEMBLY INSTRUCTION

DOUBLE X-BACK SIDE CHAIR

A Chair Back

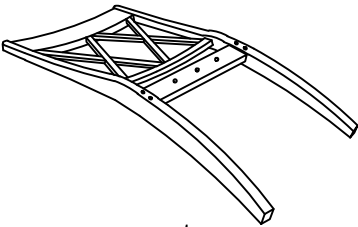

1pc

B Box Frame

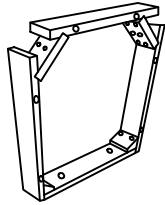

1pc

C Wooden Seat

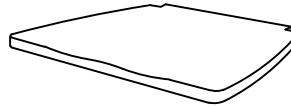

1pc

D Front Leg (L & R)

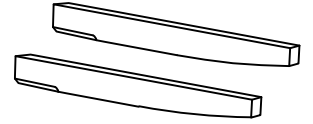

2pcs

E Jcbc Bolt M6 x 70mm

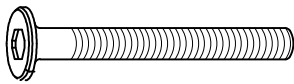

4pcs

F Jcbc Bolt M6 x 60mm

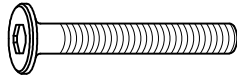

4pcs

G Jcbc Bolt M6 x 40mm

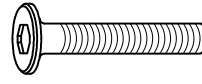

2pcs

H Lock Washer M6



10pcs

I Flat Washer M6 x 16mm
1.2 mm



10pcs

J Csk-Cb Screw #8 x 1"

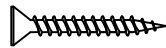

6pcs

K Allen Key M4 x 60mm



1pc

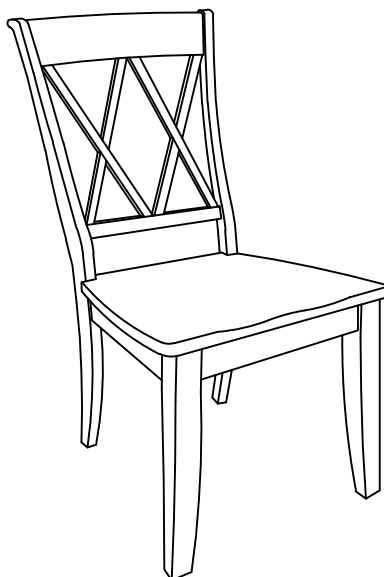

This page lists all the contents included in the box. Please take the time to identify the hardware as well as the individual components to this product. As you unpack and prepare for assembly, place the contents on a carpeted or padded area to protect them from damage.

1

Put the Chair Back (A) Box Frame (B) upside down on the soft and smooth surface. With assistance attach Box Frame (B) onto Chair Back (A). Then insert Jcbc Bolt (E), Lock Washer (H) and Flat Washer (I) into predrilled holes of each corner, by using Allen Key (K). Insert Jcbc Bolt (G), Lock Washer (H) and Flat Washer (I) into the predrilled holes of the middle of Chair Back (A), by using Allen Key (K). Do not fully tighten the bolts in this step.

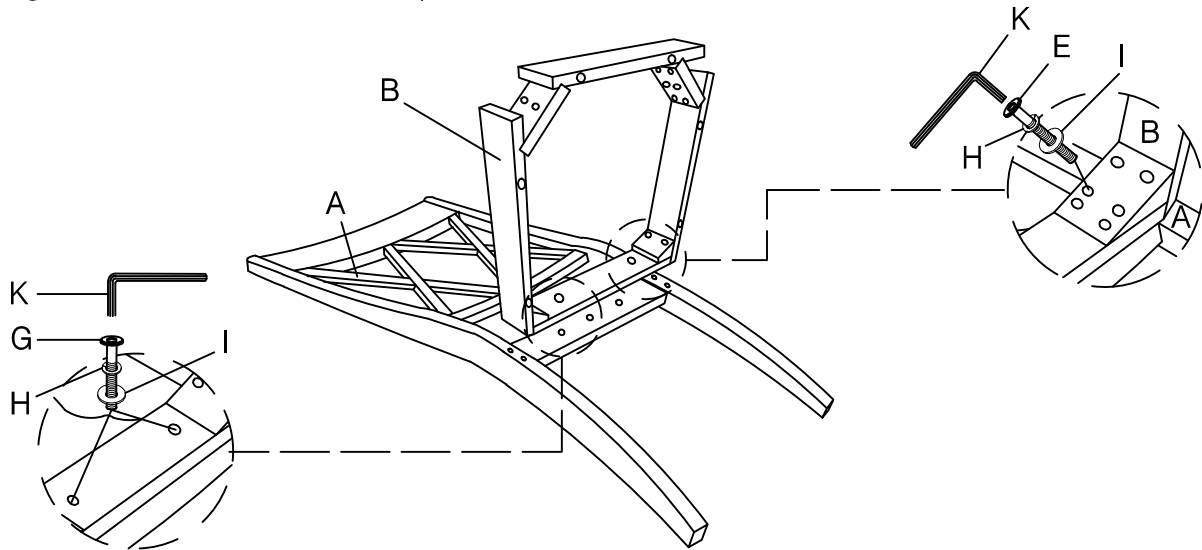

Take the Allen Wrench, and turn the bolts until the legs are secure. **DO NOT TIGHTEN COMPLETELY.** Stop when you feel you are adding force to tighten the bolt.

2

Attach Chair Legs (D) and corner of Box Frame (B), insert Flat Washer (I), Lock Washer (H) and Jcbc Bolt (F) using Allen Key (K).

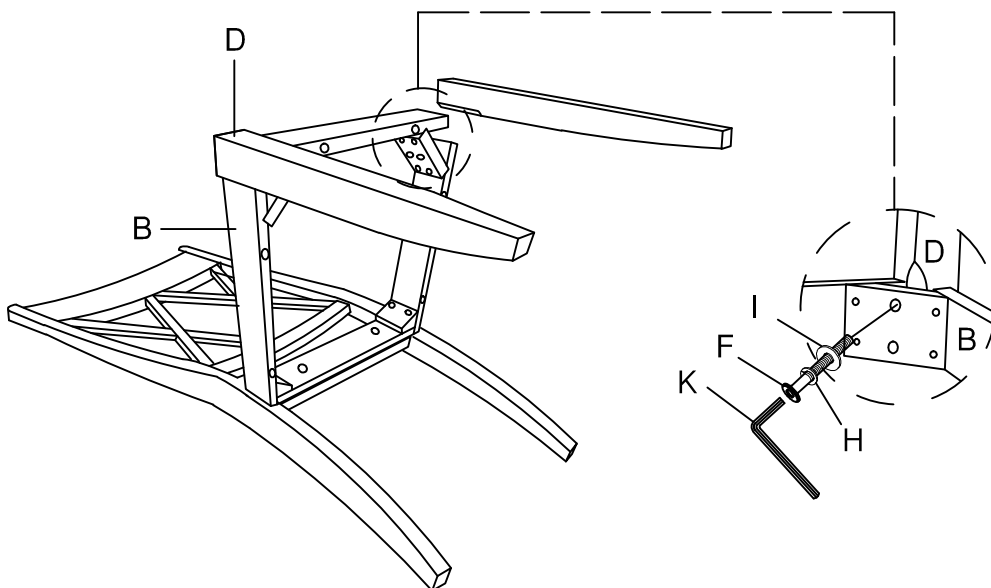

-
- 3** Attach Wooden Seat (C) and Box Frame (B) with Csk-Cb Screw (J) by using Screwdriver (not included). Tighten all wood screws in this step.

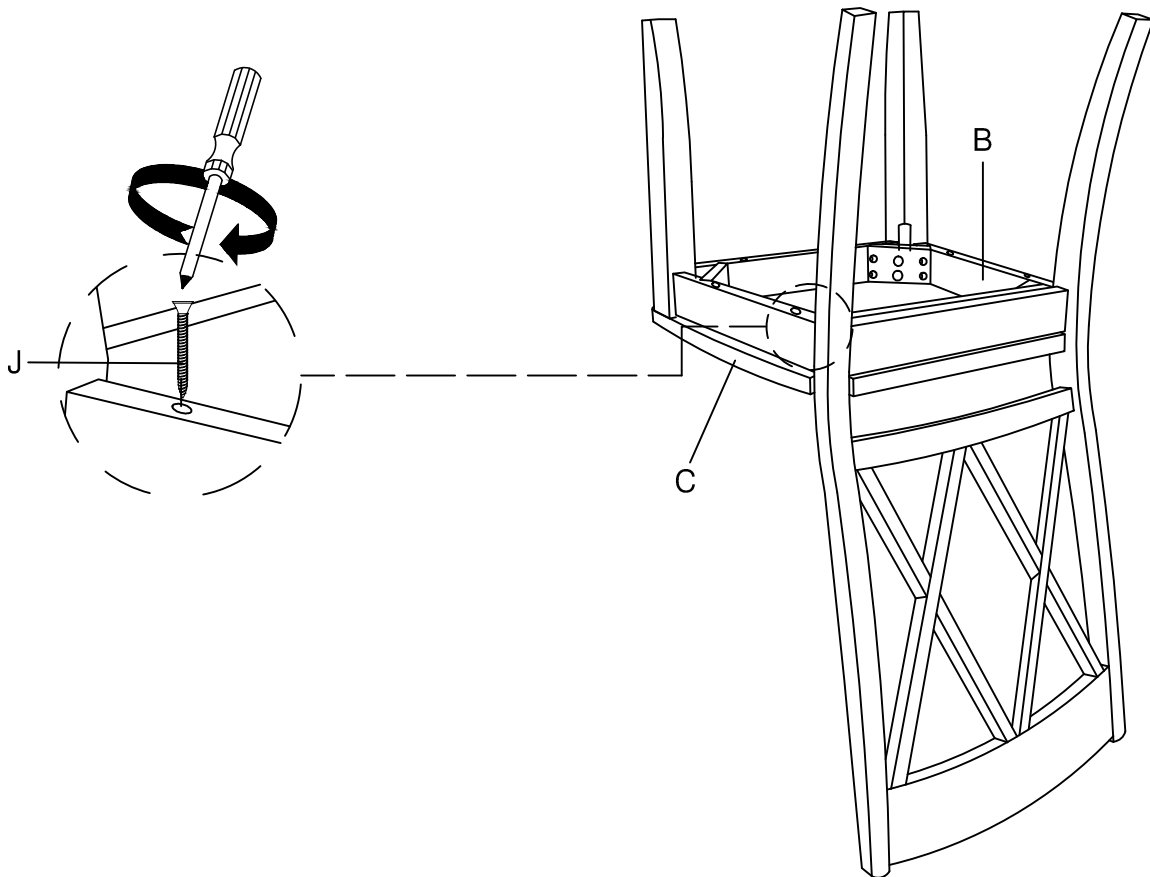

Stand chair up on an even surface and check that it is balanced. If there is a slight wobble, apply downward pressure in the corner where a leg is uneven. Keeping pressure in that corner, tighten all bolts. If balanced, apply downward pressure evenly in the center and tighten all bolts. Do not over-tighten beyond hole depth.









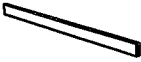

Helpful Tip:- Instead of applying downward pressure while reaching under to tighten bolts, have someone sit in the chair while you tighten the bolts.

Cleaning & Care

Treat surface with care. Surface is resistant to scratches but is not scratch resistant. Clean surface with a dry or damp soft cloth. Do not use abrasive cleaners. Hardware may loosen over time. Periodically check that all connections are tight.

ASSEMBLY INSTRUCTION

DINING BENCH WITH TRESTLE LEG

A WOODEN SEAT  1 PC	B TRESTLE LEG  2 PCS	C BASE  2 PCS	D TRESTLE BAR  1 PC
E SUPPORT BAR (Unloose from step 1)  2 PCS	F ALLEN WRENCH  1 PC	G JCBC M6 x 35mm (Included 4 pcs from step 1)  16 PCS	H JCBC M6 x 70mm  12 PCS
I SPRING WASHER M6 (Included 4 pcs from step 1)  28 PCS	J FLAT WASHER M6 (Included 4 pcs from step 1)  8 PCS	K PVC DOWEL M8 x 30mm  2 PCS	L WOOD BUTTON  4 PCS

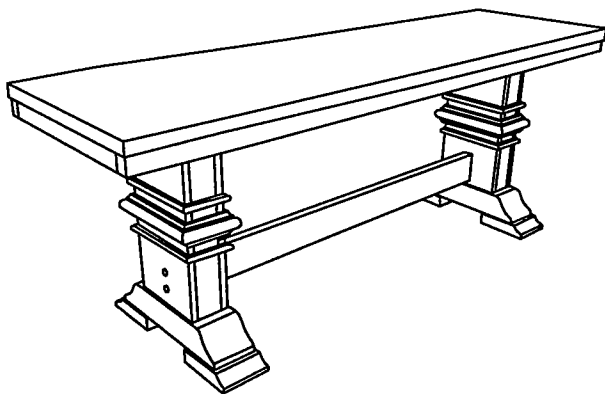

This Page lists all the contents included in the box . Please take the time to identify the hardware as well as the individual components to this product . As you unpack and prepare for assembly , place the contents on a carpeted or padded area to protect them from damage .

1 Please unloose bolt, spring washer and flat washer from support bar(E) with Allen wrench(F). Keep the hardware for step 5 and support bar for step 2 use.

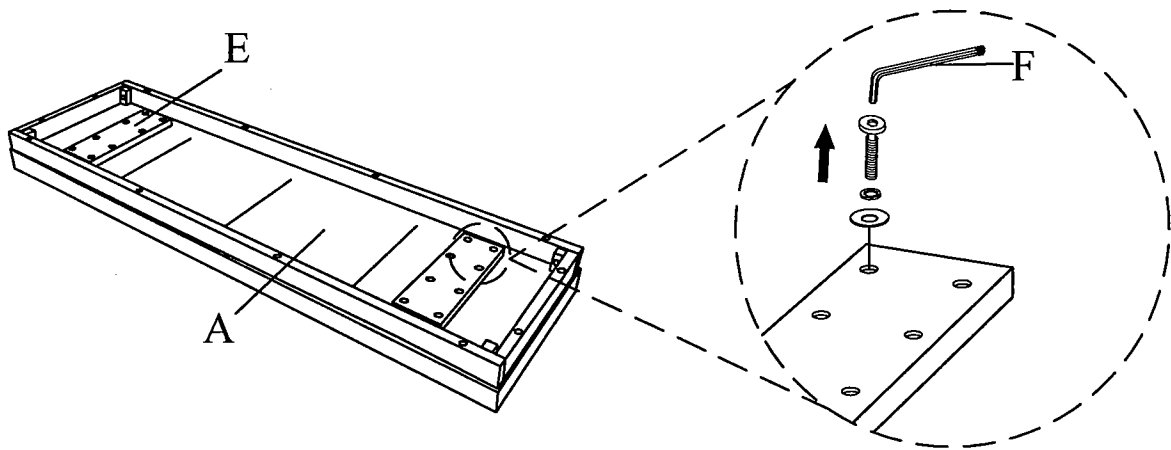

2 Align and fasten support bar(E) to trestle leg(B) using short bolt(G) and spring washer(I) which unloose from step 1 and tighten with Allen wrench(F).
** Do not fully tighten the nut or bolt until all nuts and bolts are attached.

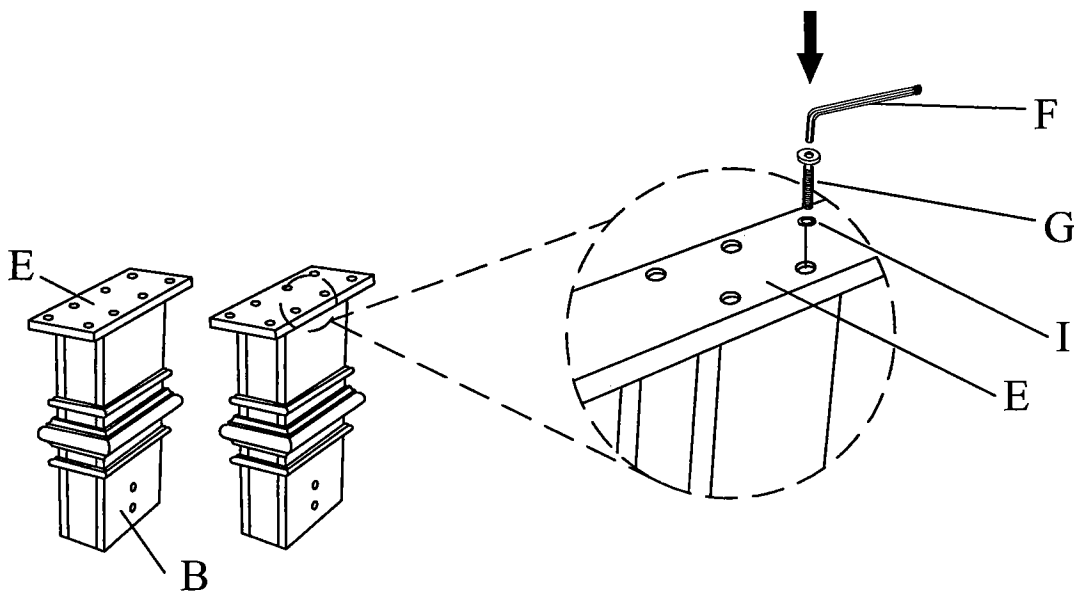

-
- 3** i) Insert pvc dowel(K) to both end of trestle bar(D).
ii) Align and fasten trestle bar(D) to trestle leg(B) using long bolt(H) and spring washer(I) and tighten with Allen wrench(F). Insert wood button(L) to cover the open hole of the leg.

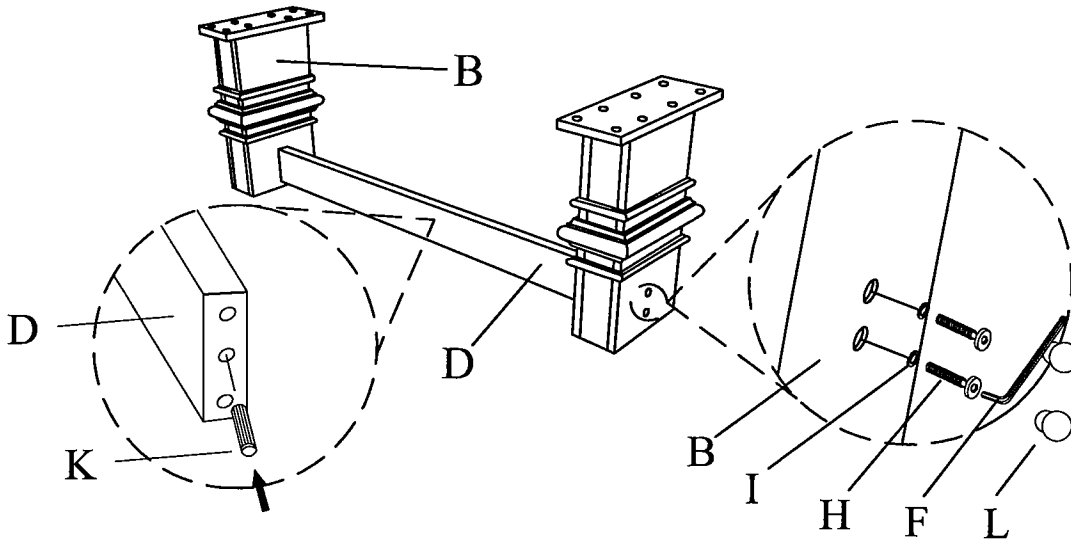

-
- 4** Flip bench leg over, align and fasten bottom base(C) to trestle leg(B) using long bolt(H) and spring washer(I). Tighten bolts with Allen wrench(F).
**** Do not fully tighten the nut or bolt until all nuts and bolts are attached.**

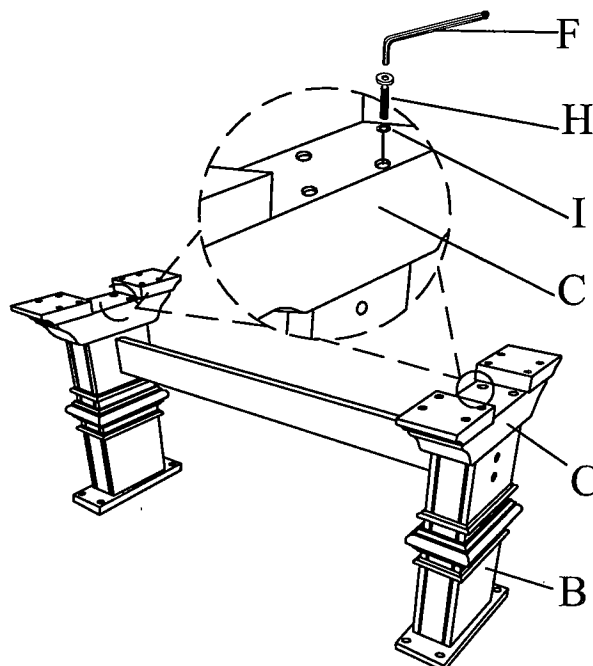

5 Place wooden seat upside down on soft surface. Align and fasten support bar(E) to wooden seat(A) using short bolt(G), spring washer(I) and flat washer(J) and tighten with Allen wrench(F).

**** Do not fully tighten the nut or bolt until all nuts and bolts are attached.**

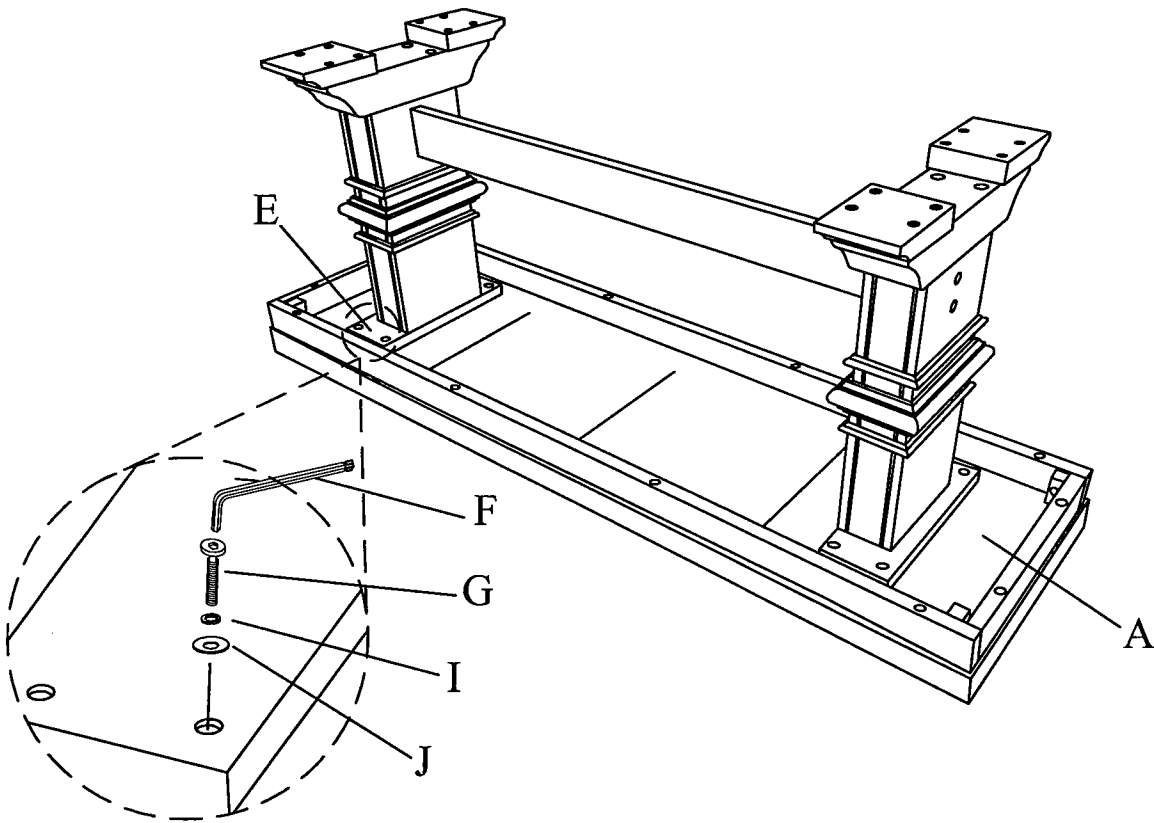

Cleaning & Care

Treat Surface with care. Surface is resistant to scratches but is not scratch resistant. Clean surface with a dry or damp soft cloth. Do not use abrasive cleaners. Hardware may loosen over time. Periodically check that all connections are tight.