





# ASSEMBLY INSTRUCTIONS



## TABLE, COCKTAIL

**Read instructions carefully prior to assembly.**

Thank you for purchasing this quality product. Check carefully for small parts which may come loose during shipment. Remove all components from pack and place top down on soft surface such as carpet or cloth to prevent scratching the finish. Identify and count all parts as specified below.

**It is recommended to use two or more persons during the assembly process.**

Parts List			
No.	Description	Sketch	Q'TY
A	Top Frame		1 PC
B	Shelf		1 PC
C	Bottom Panel		1 PC
D	Glass Top		1 PC
E	Legs		4 PCS

Hardware List			
No.	Description	Sketch	Q'TY
1	Allen Bolt 1/4" x 50mm		4PCS
2	Allen Bolt 1/4" x 28mm		8PCS
3	Spring Washer 1/4"		12PCS
4	Flat Washer 1/4"		12PCS
5	Allen Key M4		1PC
6	Screw		16PCS
7	Wheel		4PCS

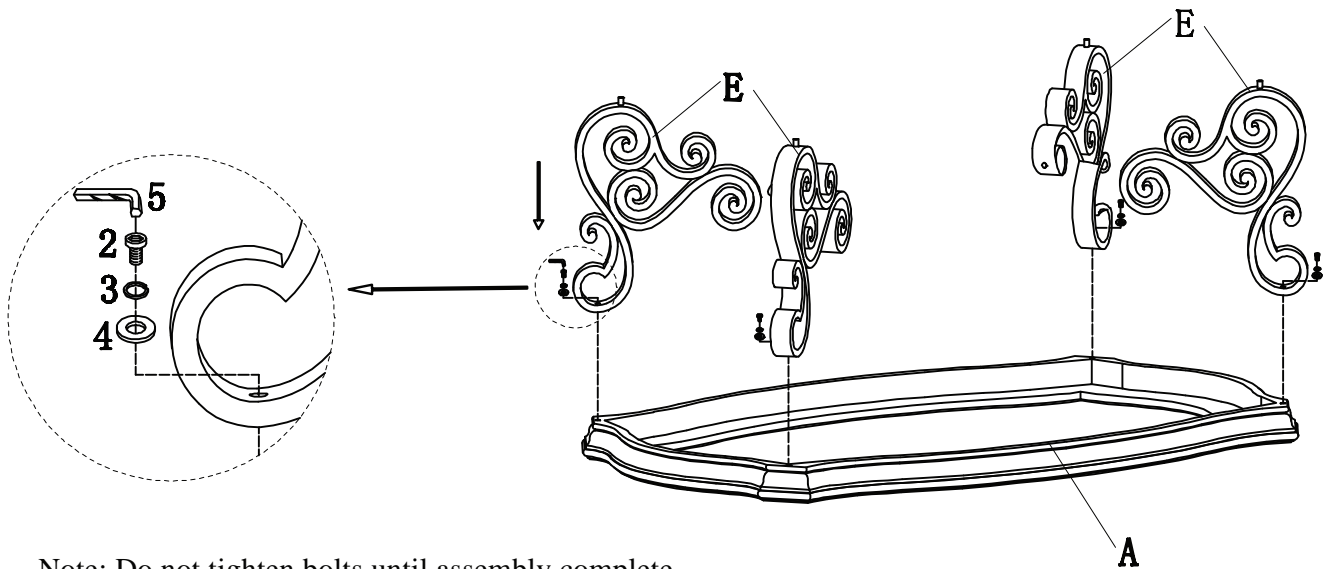

Note: Do not tighten bolts until assembly complete.

**STEP1:**

Place Top Frame (A) on a soft flat, attach four Legs (E) to Top Frame (A) by using Allen Key M4 (5) Flat Washer 1/4"(4), Spring Washer 1/4"(3), Allen Bolt 1/4"x 28mm (2).

# ASSEMBLY INSTRUCTIONS

## TABLE, COCKTAIL

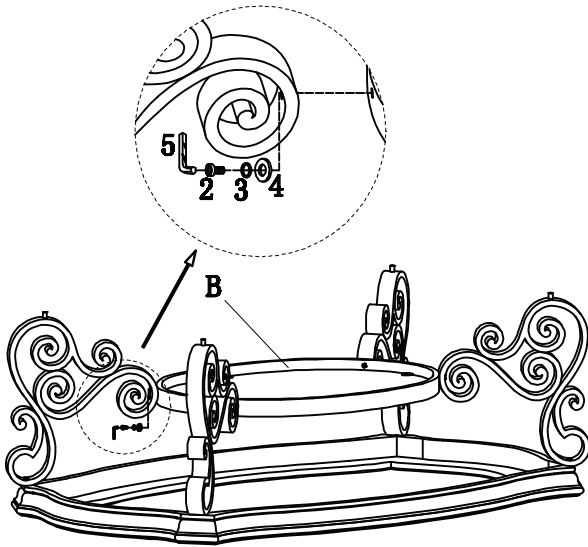

**STEP 2 :**  
Attach Shelf (B) to Legs (E) by using  
Allen Key M4 (5), Allen Bolt 1/4" x 28mm (2)  
Spring Washer 1/4" (3), Flat Washer 1/4" (4)

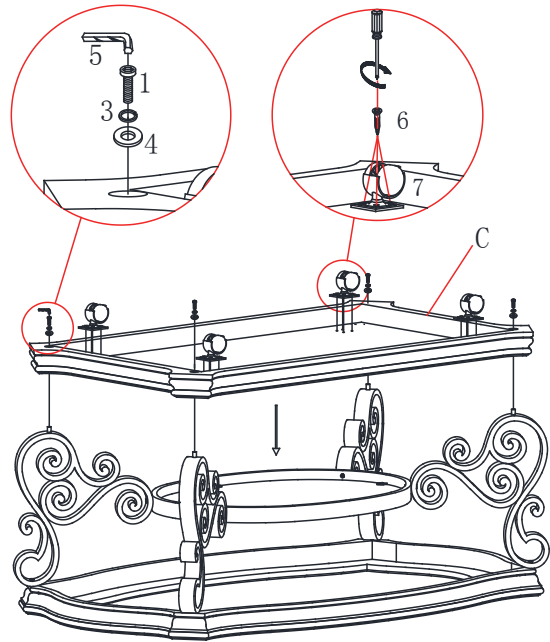

**STEP 3 :**  
Attach Bottom Panel (C) to Legs (E) by using  
Allen Key M4 (5), Allen Bolt 1/4" x 50mm (1)  
Spring Washer 1/4" (3), Flat Washer 1/4" (4)  
Attach Wheel (7) to Bottom Panel (C) by using Scwric (6)

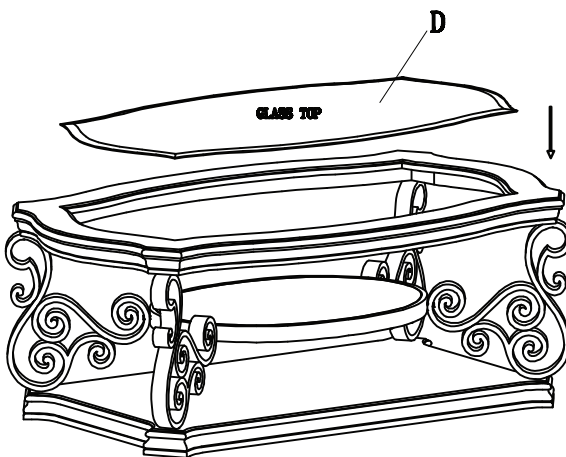

**STEP 4 :**  
Turn over the table. Tighten all bolts carefully  
and Insert Glass top (D) into the Top Frame (A)

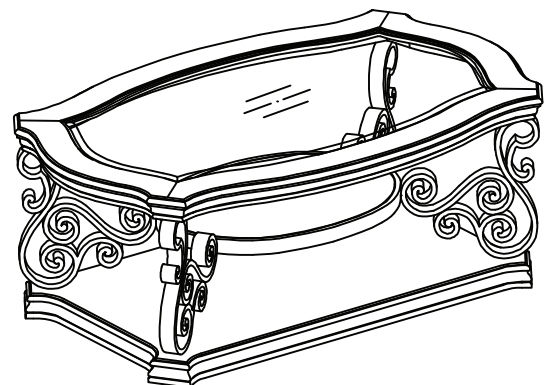

**STEP 5 :**  
Assembly is completed





# ASSEMBLY INSTRUCTIONS





## TABLE,END

**Read instructions carefully prior to assembly.**

Thank you for purchasing this quality product. Check carefully for small parts which may come loose during shipment. Remove all components from pack and place top down on soft surface such as carpet or cloth to prevent scratching the finish. Identify and count all parts as specified below.

**It is recommended to use two or more persons during the assembly process.**

Parts List			
No.	Description	Sketch	Q'TY
A	Top Frame		1 PC
B	Shelf		1 PC
C	Bottom Panel		1 PC
D	Glass Top		1 PC
E	Legs		4 PCS

Hardware List			
No.	Description	Sketch	Q'TY
1	Allen Bolt 1/4" x 50mm		4PCS
2	Allen Bolt 1/4" x 28mm		8PCS
3	Spring Washer 1/4"		12PCS
4	Flat Washer 1/4"		12PCS
5	Allen Key M4		1PC

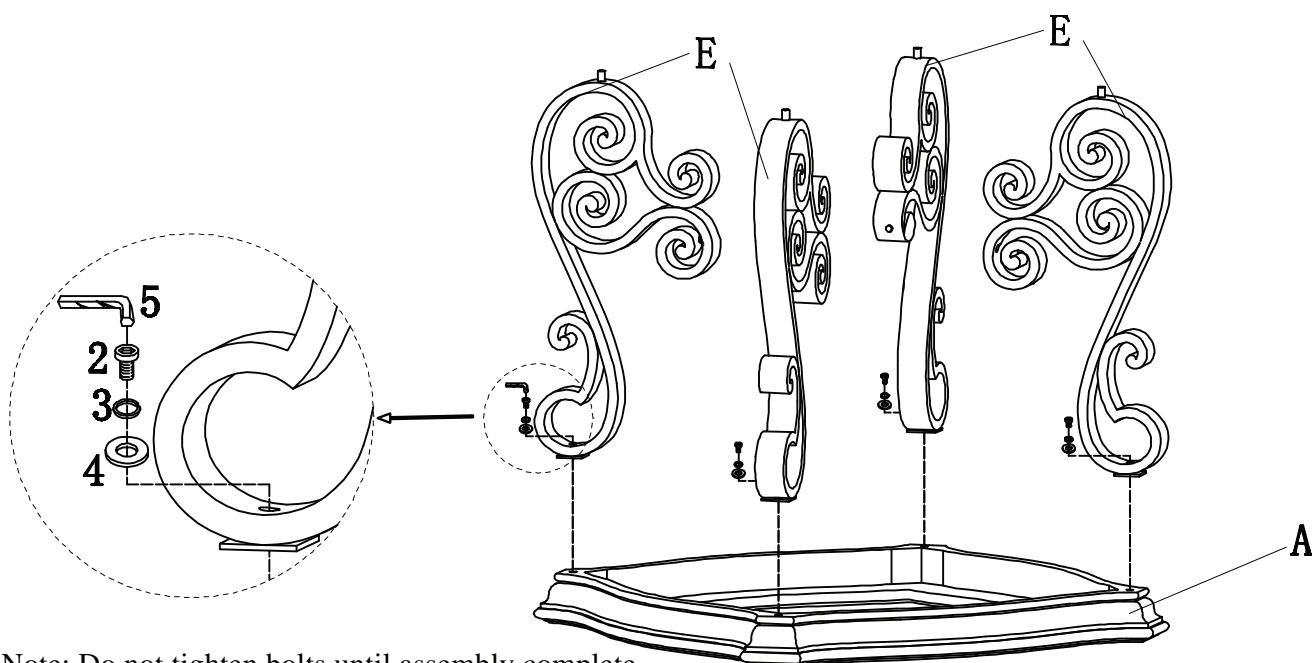

Note: Do not tighten bolts until assembly complete.

### STEP 1:

Place Top Frame (A) on a soft flat, attach four Legs (E) to the Top Frame (A) by using Allen Key M4 (5) Allen Bolt 1/4" x 28mm (2), Spring Washer 1/4" (3), Flat Washer 1/4" (4)

# ASSEMBLY INSTRUCTIONS

## TABLE,END

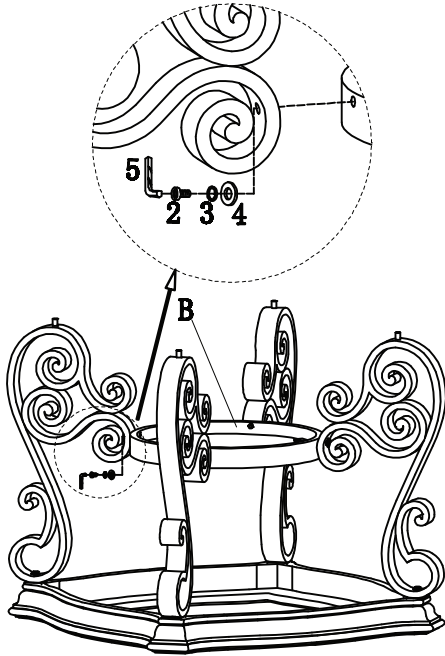

### STEP 2 :

Attach Shelf ( B) to Legs (E) by using Allen Key M4 (5),Allen Bolt 1/4" x1"28mm (2), Spring Washer 1/4" (3), Flat Washer 1/4" (4)

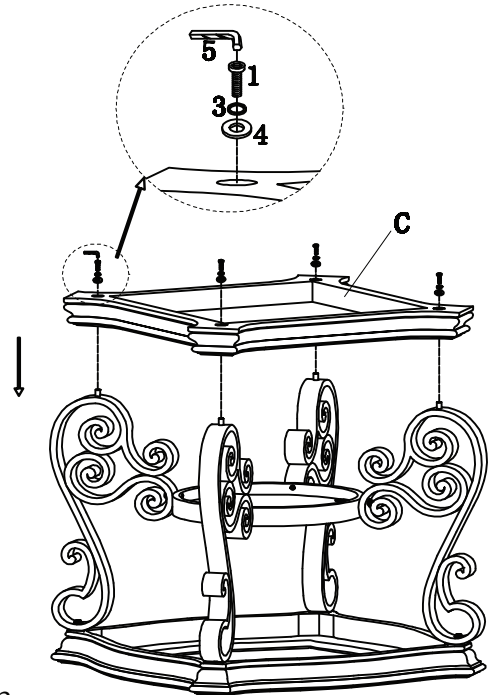

### STEP 3:

Attach Bottom Panel (C) to Legs (E) by using Allen Key M4 (5),Allen Bolt 1/4"x 50mm (1), Spring Washer 1/4"(3), Flat Washer 1/4"(4)

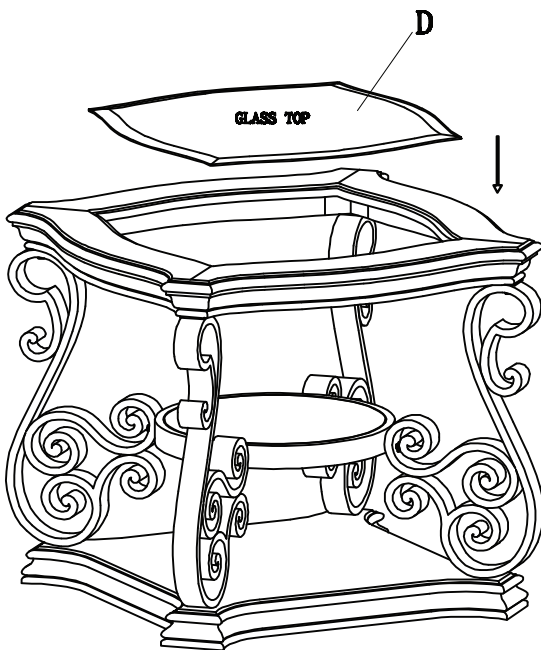

### STEP 4 :

Turn over the table. Tighten all bolts carefully and Insert Glass top (D) into the Top Frame (A)

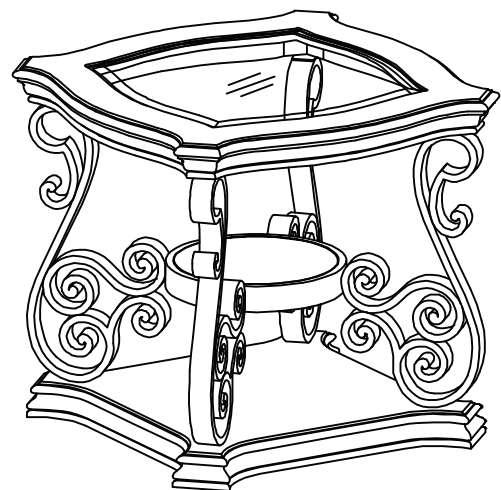





### STEP 5 :



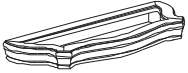

Assembly is completed.

**Read instructions carefully prior to assembly.**

Thank you for purchasing this quality product. Check carefully for small parts which may come loose during shipment. Remove all components from pack and place top down on soft surface such as carpet or cloth to prevent scratching the finish. Identify and count all parts as specified below.

**It is recommended to use two or more persons during the assembly process.**

Parts List			
No.	Description	Sketch	Q'TY
A	Top Frame		1 PC
B	Shelf		1 PC
C	Bottom Panel		1 PC
D	Glass Top		1 PC
E	Legs		4 PCS

Hardware List			
No.	Description	Sketch	Q'TY
1	Allen Bolt 1/4" x 50mm		4PCS
2	Allen Bolt 1/4" x 28mm		8PCS
3	Spring Washer 1/4"		12PCS
4	Flat Washer 1/4"		12PCS
5	Allen Key M4		1PC

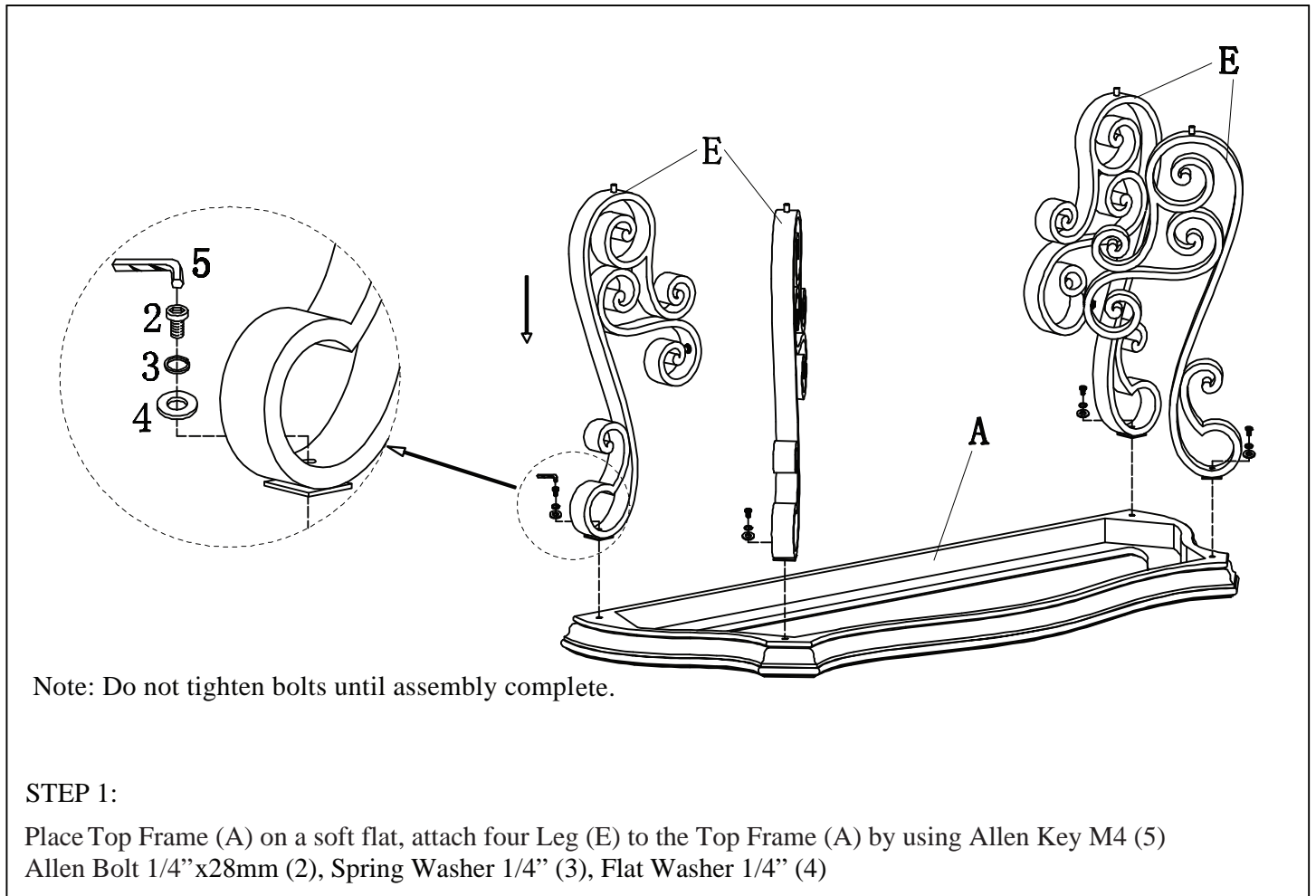

Note: Do not tighten bolts until assembly complete.

**STEP 1:**

Place Top Frame (A) on a soft flat, attach four Leg (E) to the Top Frame (A) by using Allen Key M4 (5) Allen Bolt 1/4"x28mm (2), Spring Washer 1/4" (3), Flat Washer 1/4" (4)

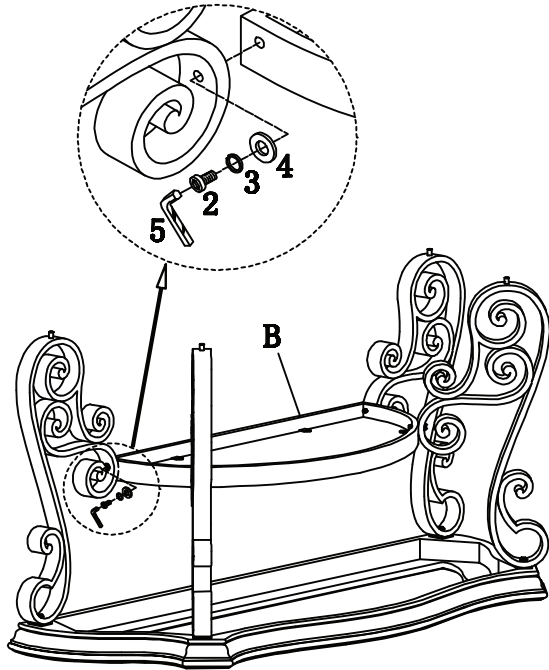

**STEP 2:**  
 Attach Shelf (B) to Legs (E) by using Allen Key M4 (5), Allen Bolt 1/4" x 28mm (2), Spring Washer 1/4" (3), Flat Washer 1/4" (4)

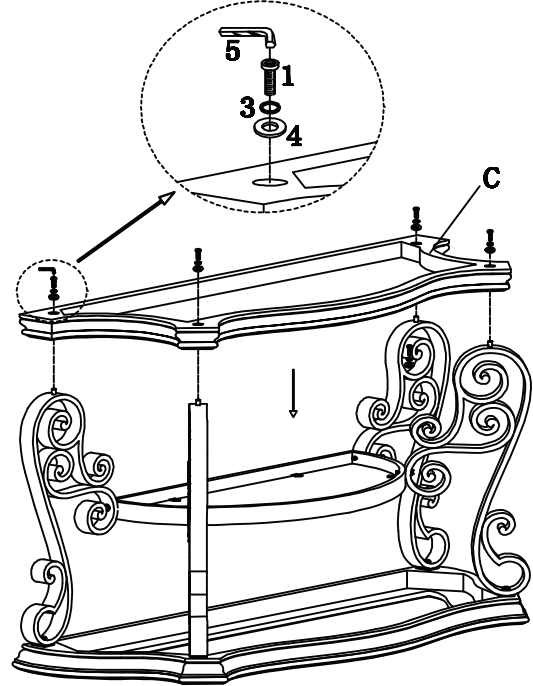

**STEP 3:**  
 Attach Bottom Panel (C) to Legs (E) by using Allen Key M4 (5), Allen Bolt 1/4" x 50mm (1), Spring Washer 1/4" (3), Flat Washer 1/4" (4)

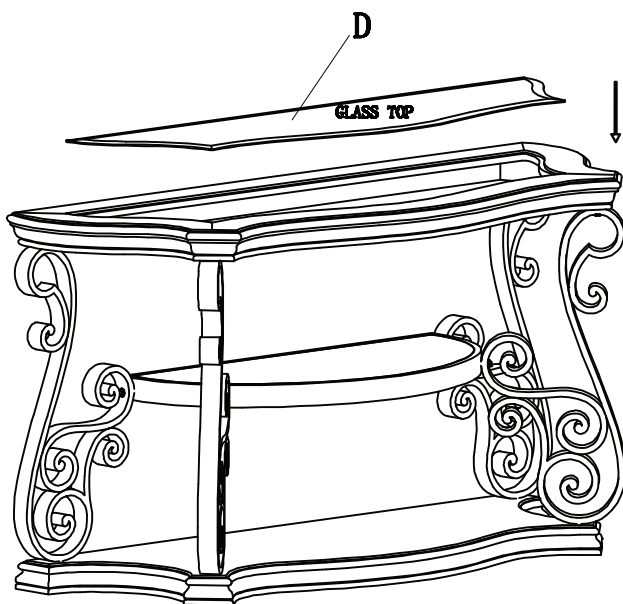

**STEP 4:**  
 Turn over the table. Tighten all bolts carefully and Insert Glass top (D) into the Top Frame (A)



**STEP 5:**  
 Assembly is completed.