

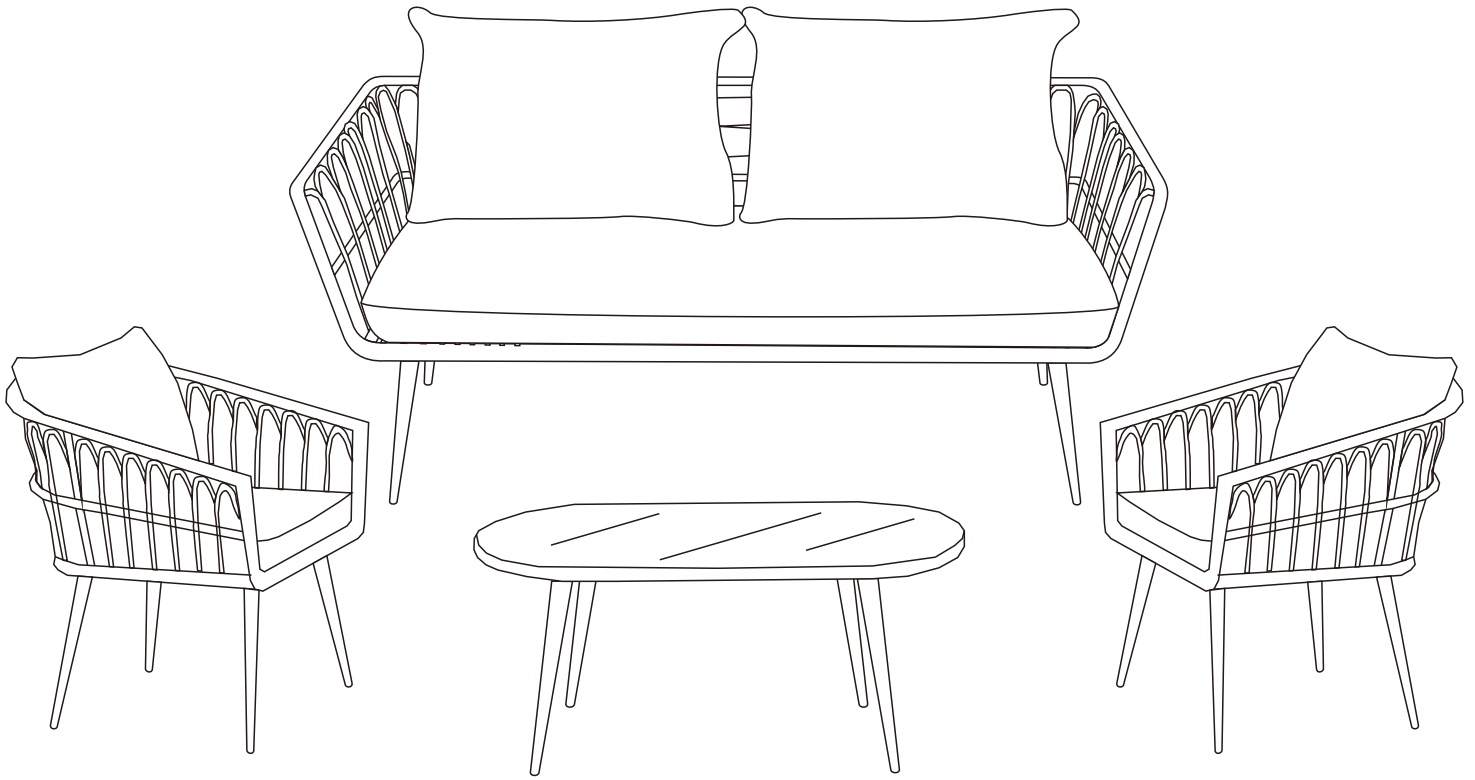





# Assembly Instructions



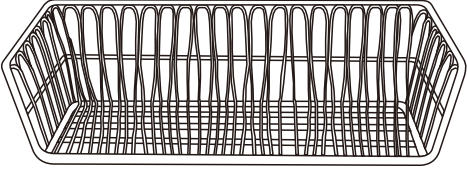
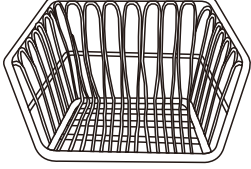

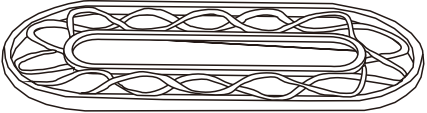
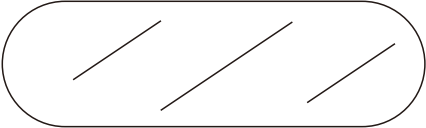
## TIPS

1. Insert the screws in holes and tighten the screws. but not too tight, 50% is ok, finally tighten all the screws. If some issues happened that some screws can not target to the hole or some parts are difficult to install. please adjust the tightness of the screws.

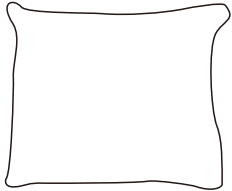
2. 2 people are recommended to finish

<p><b>A</b></p>  <p>x1</p>	<p><b>B</b></p>  <p>x2</p>	<p><b>C</b></p>  <p>x12</p>
<p><b>D</b></p>  <p>x1</p>	<p><b>E</b></p>  <p>x1</p>	<p><b>F</b></p>  <p>x4</p>
<p><b>G</b></p>  <p>x1</p>	<p><b>H</b></p>  <p>x2</p>	<p><b>J</b></p>  <p>x4</p>

<p><b>1</b></p>  <p>M6*16</p> <p>x64</p>	<p><b>2</b></p>  <p>x64</p>	<p><b>3</b></p>  <p>x1</p>		
---	--	---	--	--

NOTE:50% TIGHTEN BEFORE FIXING ALL BOLTS

01

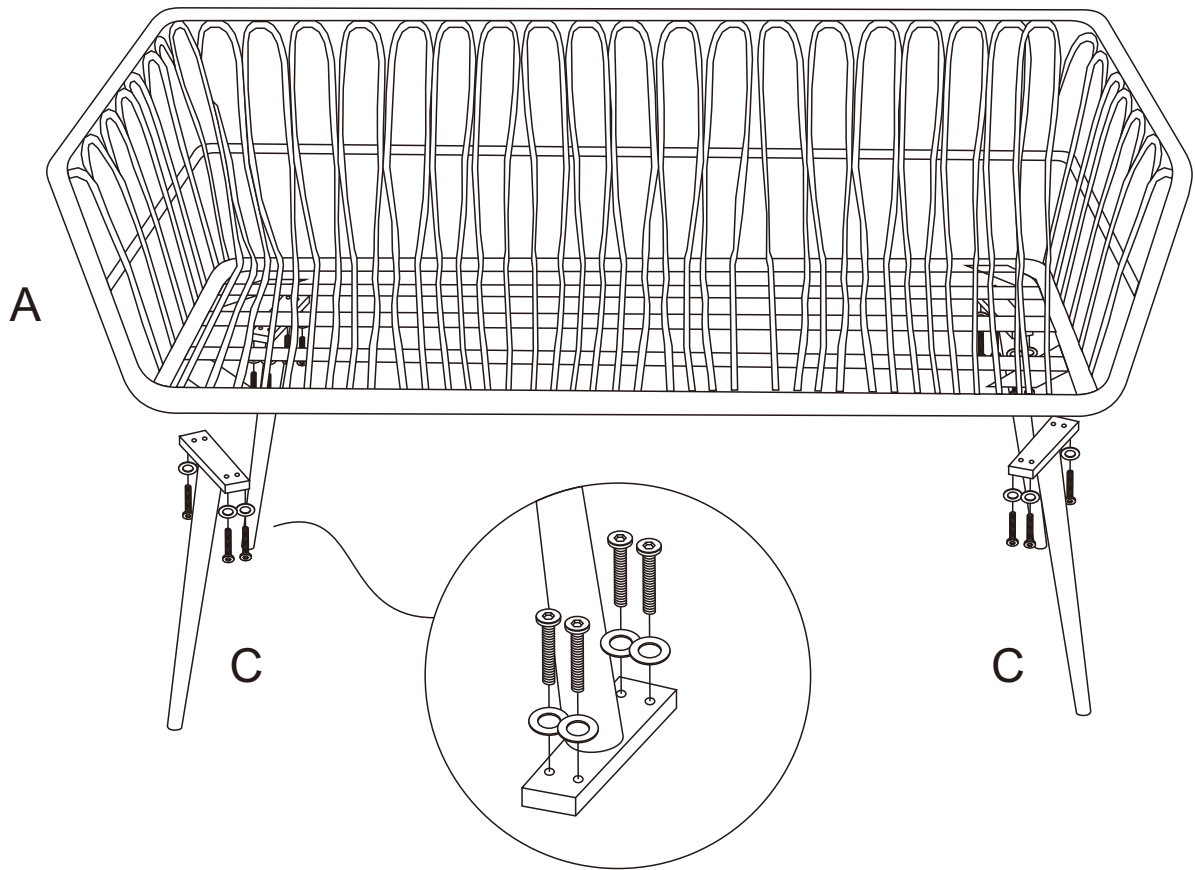

02

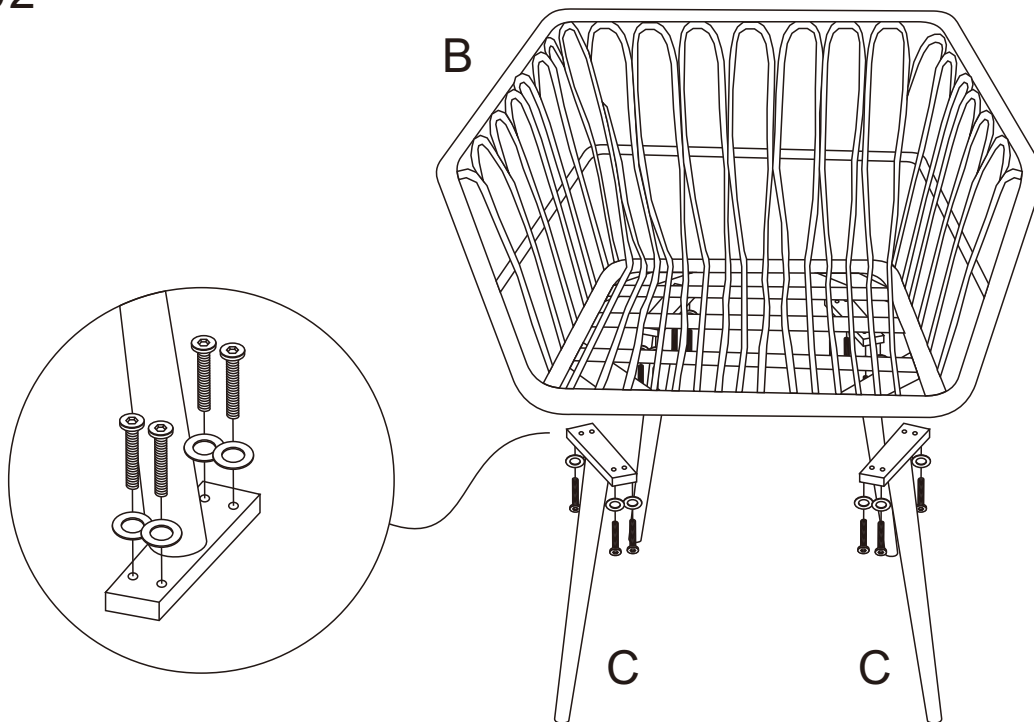

NOTE:50% TIGHTEN BEFORE FIXING ALL BOLTS

03

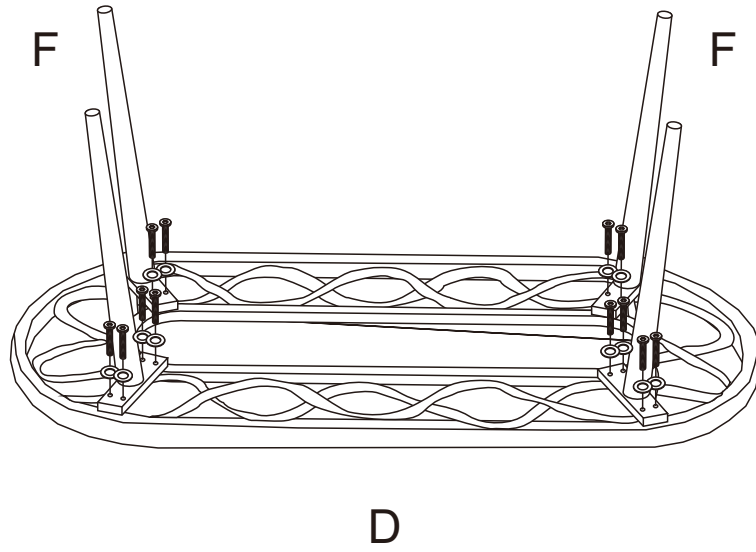

04

