

SAFETY INFORMATION



Please read and understand this entire manual before attempting to assemble, operate or install the product.



WARNING

- Some steps are more easily handled with two adults.

CAUTION

- Before assembly and/or installation, carefully unwrap all parts.
- Locate and set aside the hardware kit before discarding packaging.
- Use care when assembling your new product. Take your time and follow assembly instructions closely.

INFORMATION DE SÉCURITÉ



Assurez-vous de lire et de comprendre l'intégralité du présent manuel avant de tenter d'assembler, d'utiliser ou d'installer le produit.



AVERTISSEMENT

- Certaines étapes sont plus faciles à effectuer avec l'aide.

MISE EN GARDE

- Avant l'assemblage et/ou l'installation, vous devez débarrasser minutieusement toutes les pièces.
- Localisez et mettez de côté le jeu de quincaillerie avant de jeter l'emballage.
- Soyez vigilant lorsque vous assemblez le nouveau produit. Prenez votre temps et suivez attentivement ces instructions.

INFORMACIÓN DE SEGURIDAD



Lea y comprenda completamente este manual antes de intentar ensamblar, usar o instalar el producto.



ADVERTENCIA

- Algunos de los pasos se pueden realizar con mayor facilidad entre dos adultos.

PRECAUCIÓN

- Antes del ensamblaje y/o instalación, desenvuelva cuidadosamente todas las piezas.
- Localice y separe el equipo de accesorios antes de desechar el embalaje.
- Tenga cuidado al ensamblar el nuevo producto. Tómese su tiempo y siga detenidamente las instrucciones de ensamblaje.

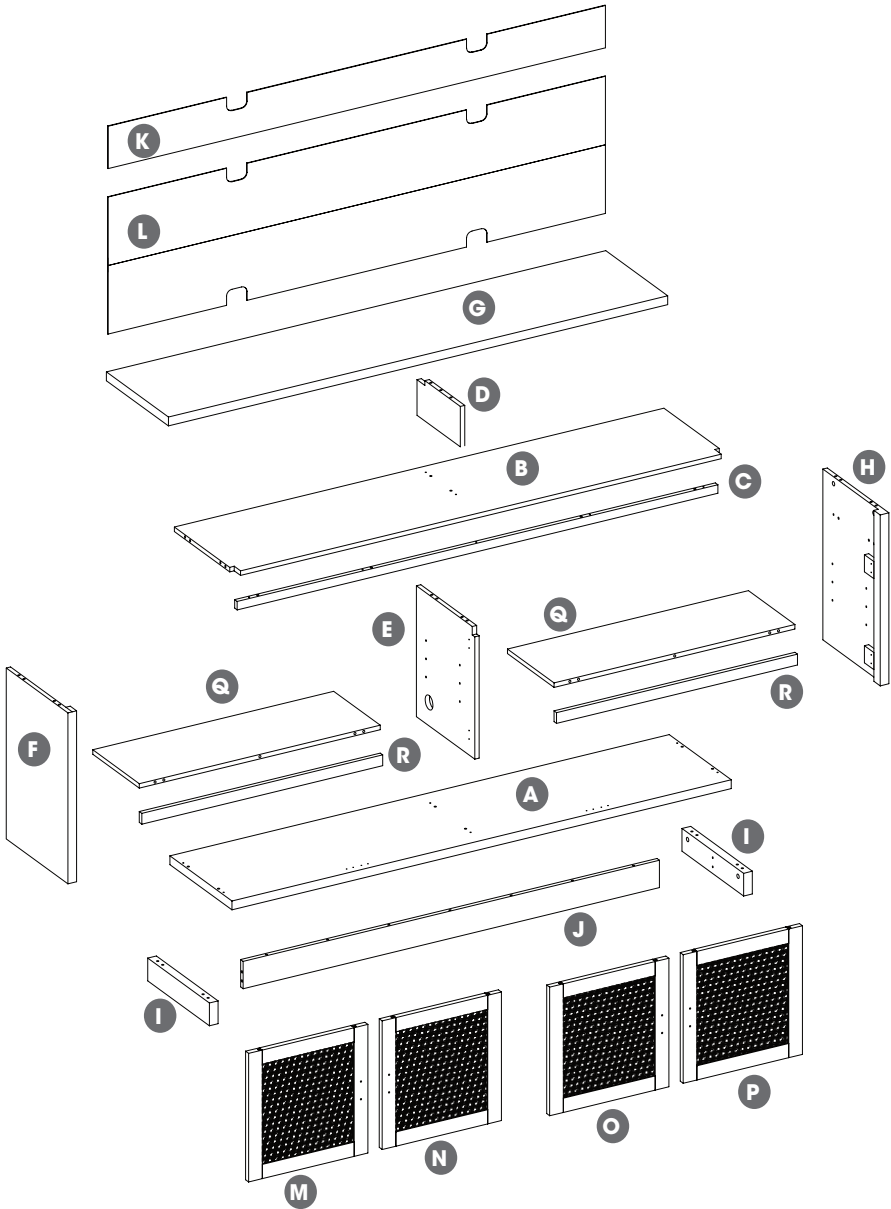

MAXIMUM LOAD
40.8 kg / 90 lb
CHARGE MAXIMALE DE
40.8 kg / 90 lb
CARGA MÁXIMA
40.8 kg / 90 lb

MAXIMUM LOAD
20.4 kg / 45 lb
CHARGE MAXIMALE DE
20.4 kg / 45 lb
CARGA MÁXIMA
20.4 kg / 45 lb

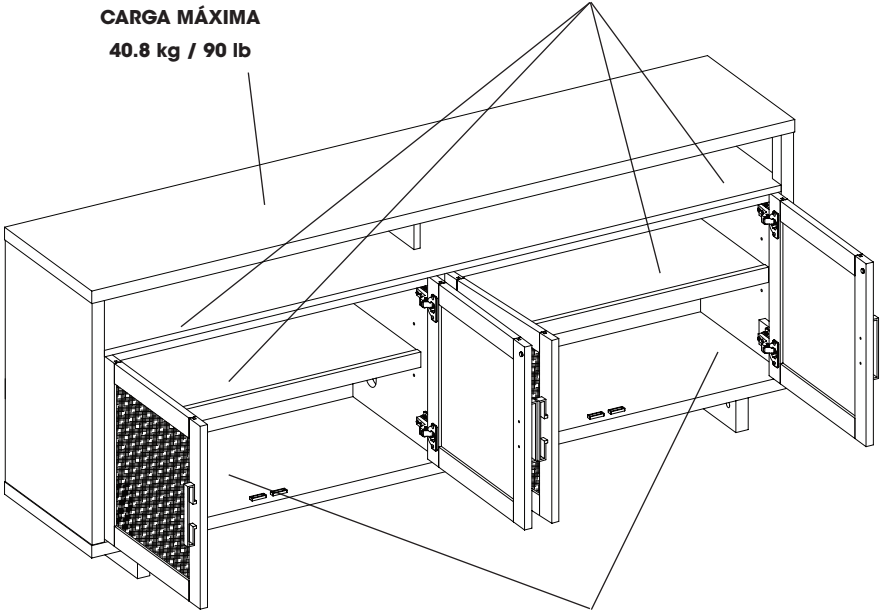

MAXIMUM LOAD
22.7kg / 50 lb
CHARGE MAXIMALE DE
22.7kg / 50 lb
CARGA MÁXIMA
22.7kg / 50 lb



WARNING

For use with most flat panel televisions weighing 40.8 kg / 90 lb or less. Usage with televisions or loads heavier than the maximum weights specified may result in instability causing tip over resulting in death or serious injury.

ATTENTION

Destiné à la plupart des téléviseurs à écran plat pesant 40.8 kg / 90 lb ou moins. L'utilisation avec des téléviseurs ou des charges dont le poids dépasse les valeurs spécifiées peut entraîner l'instabilité et le basculement pouvant provoquer la mort ou des blessures graves.

PRECAUCIÓN

Para usar con la mayoría de televisiones de flat panel, con peso de 40.8 kg / 90 lb o inferior. Colocar televisores o cargas mayores que los pesos máximos especificados puede generar inestabilidad y, en consecuencia, desplomes que pueden causar la muerte o lesiones graves.

HARDWARE / QUINCAILLERIE / FERRETERÍA

AA

[x34]



Ø8x30mm
PH-DWLNTL001

BB

[x30]



PH-KDBZNC001

CC

[x5]

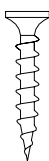

Ø4x25mm
PH-SCRBLK018

DD

[x8]



Ø4x50mm
PH-SCRBLK006

EE

[x30]



PH-KDCZNC001

FF

[x4]



PH-BMPBLK002

GG

[x8]

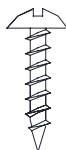

Ø3x15mm
PH-SCRBLK010

HH

[x44]

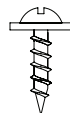

Ø3.5x12mm
PTC727030-HH

II

[x4]

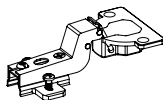

PH-HNG2H35CR95

JJ

[x4]

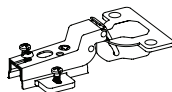

PH-HNG2H35BR95

KK

[x16]

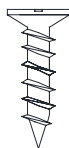

Ø3.5 x 15mm
PH-SCRNKL008

LL

[x4]



PH-BMPCLR001

HARDWARE/QUINCAILLERIE/FERRETERÍA

MM

[x4]

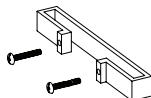

VNA10477L

NN

[x10]



PH-KDPGRY001

OO

[x8]

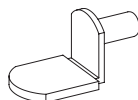

PH-SPNPCSPLB2

PP

[x1]

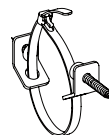

PH-FTRHH510

INSTALLED REPLACEMENT PARTS PIÈCES DE REMPLACEMENT INSTALLÉES PIEZAS DE REPUESTO INSTALADAS

QQ

[x4]

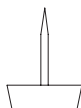

PH-GLDBRW001

ATTENTION: Follow instructions in the order they are given below. This will ensure that your product is properly assembled. To reduce the risk of damage to your furniture, please lay down a blanket, cloth, or cardboard on the floor prior to assembly.

ATTENTION: Suivre les instructions dans l'ordre donné ci-dessous. Cela vous assurera d'assembler correctement le produit. Pour réduire le risque d'endommager vos fournitures, veuillez les poser sur un tapis, un tissu ou un carton sur le sol avant l'assemblage.

ATENCIÓN: Siga las instrucciones en el orden que se indica a continuación. Esto asegurará que su producto se ensamble correctamente. Para reducir el riesgo de daño a sus muebles, por favor coloque una manta, tela o cartón en el suelo antes del montaje.

1

AA  **[x6]**

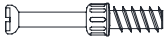
BB  **[x2]**

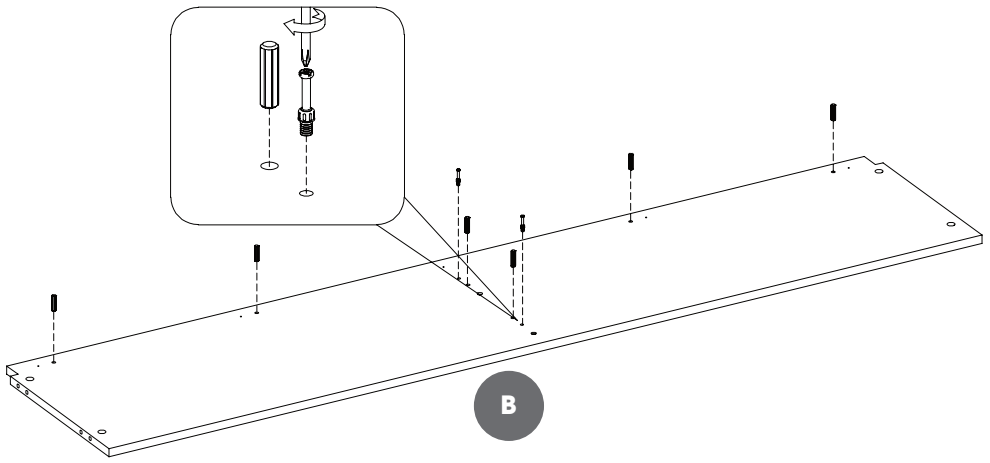

B

2

CC



[x5]

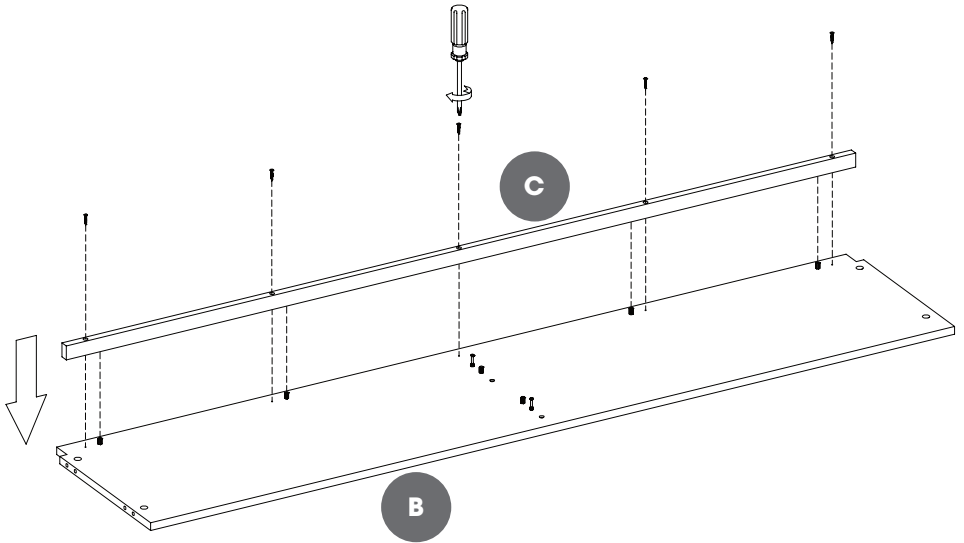

3

AA

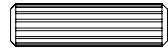

[x2]

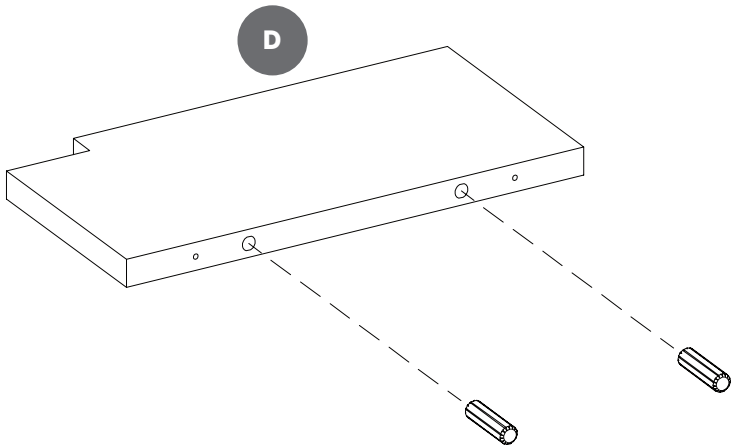

4

DD  [x2]

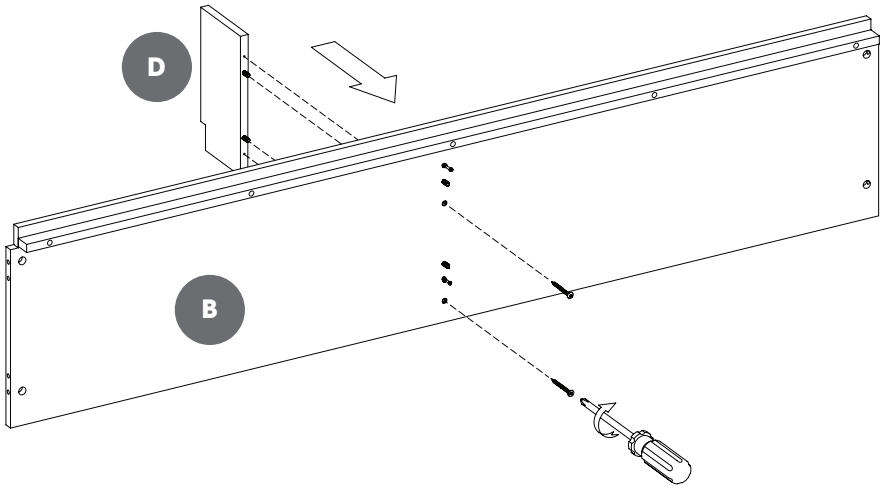

5

EE



[x2]

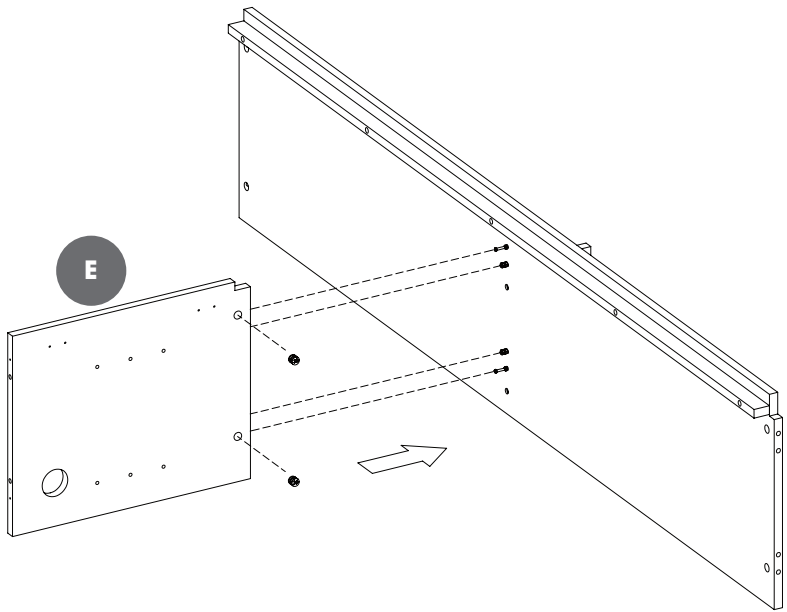
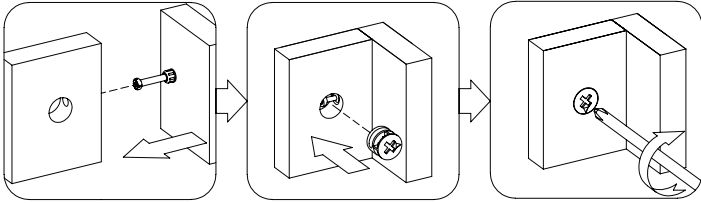

6

AA [x4]



BB [x4]

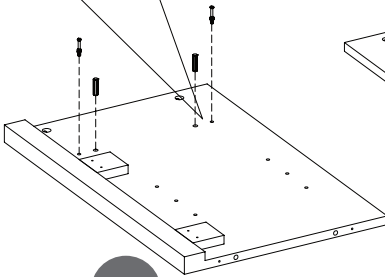
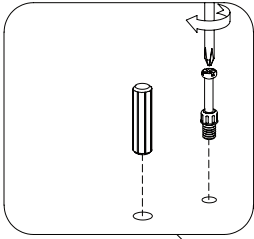
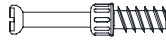

F

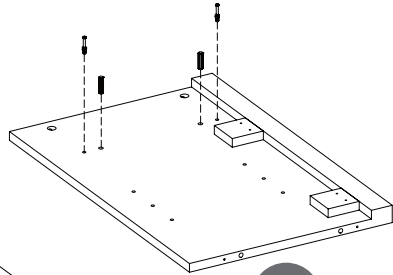

H

7

EE



[x4]

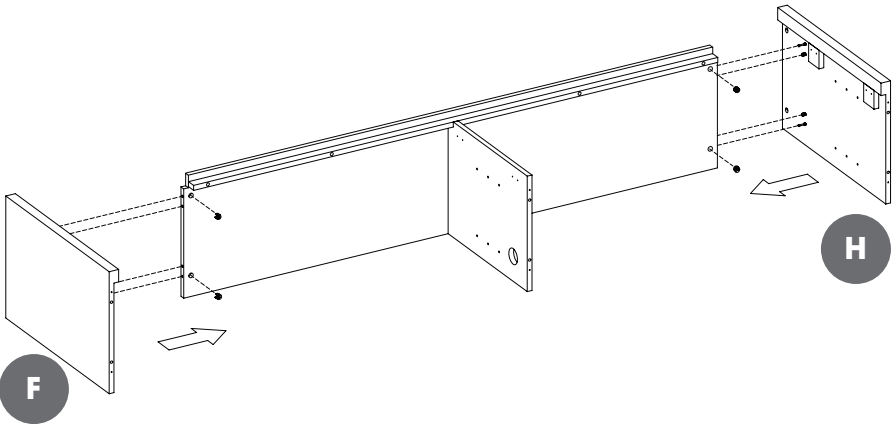
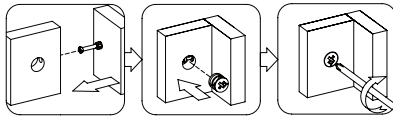

8

AA



[x6]

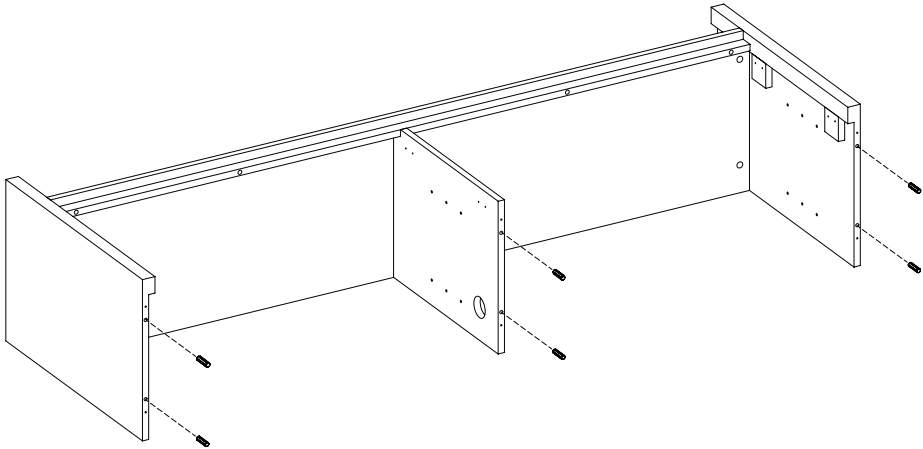

9

FF [x4]

Ge [x8]

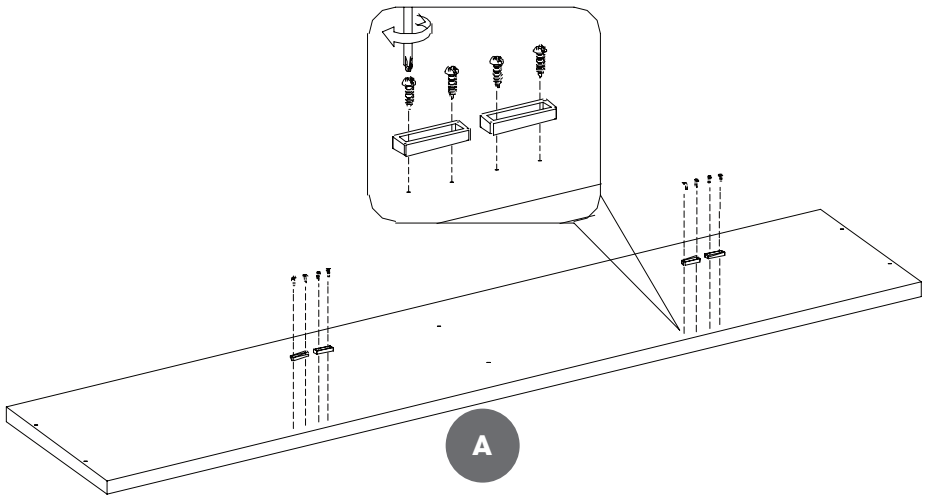

10

DD



[x6]

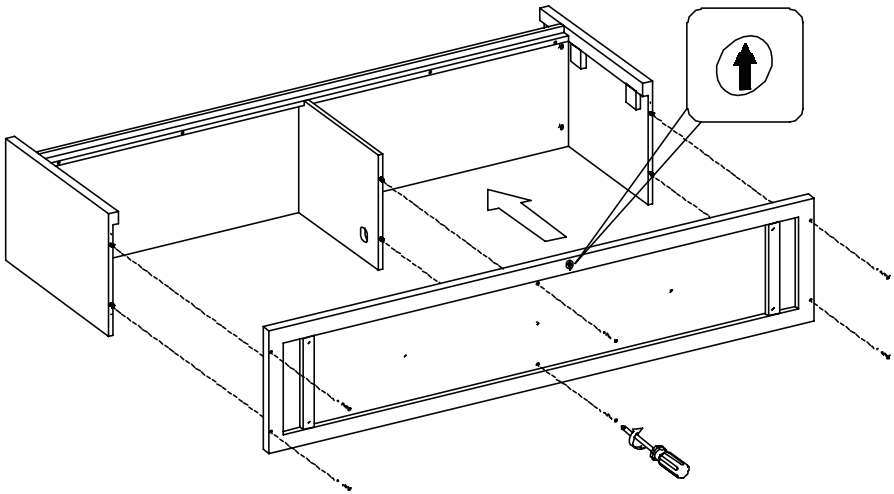

11

AA  [x7]

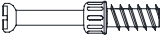
BB  [x8]

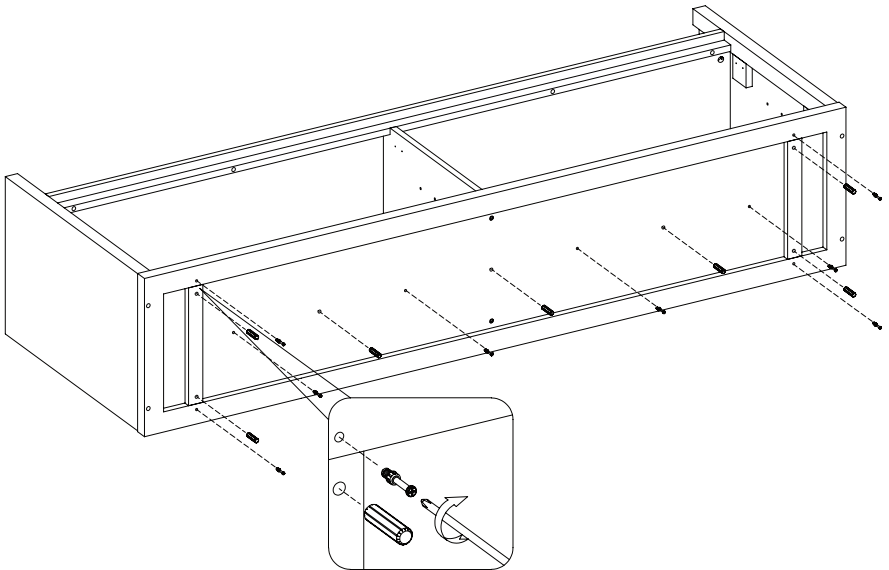

12

BB

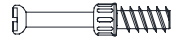

[x4]

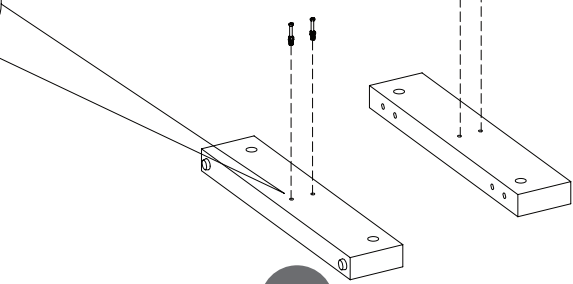
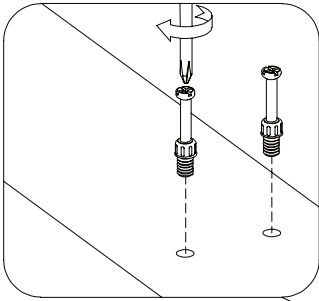

I

13

EE



[x4]

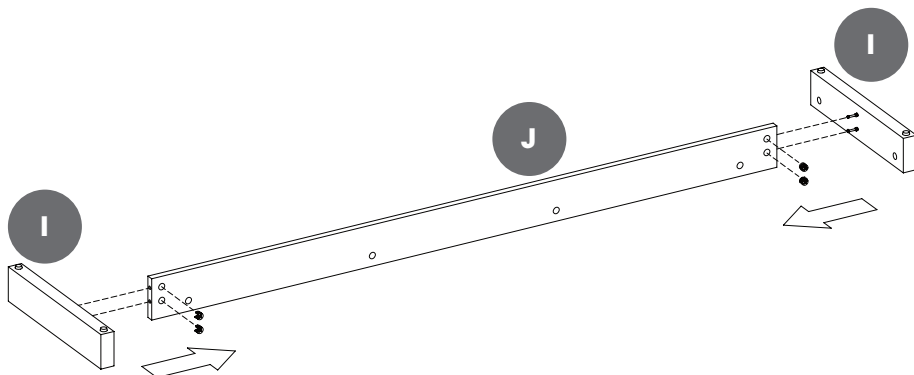
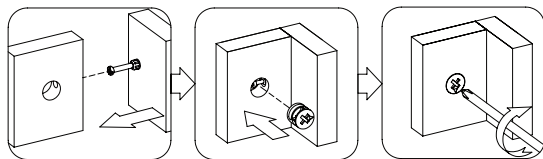

14

EE



[x8]

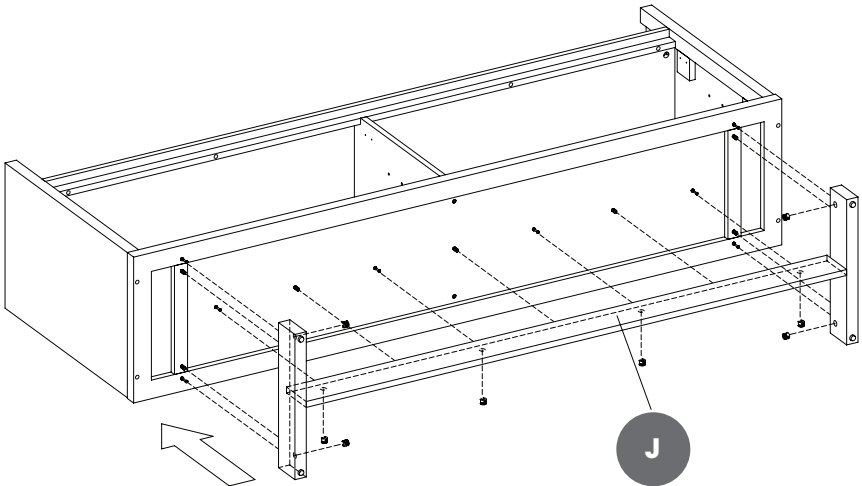
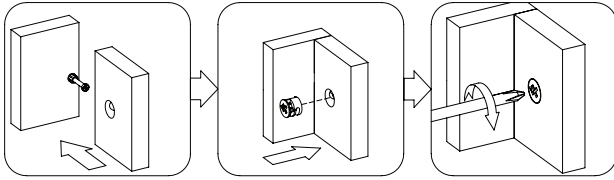

15

AA

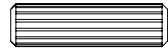

[x5]

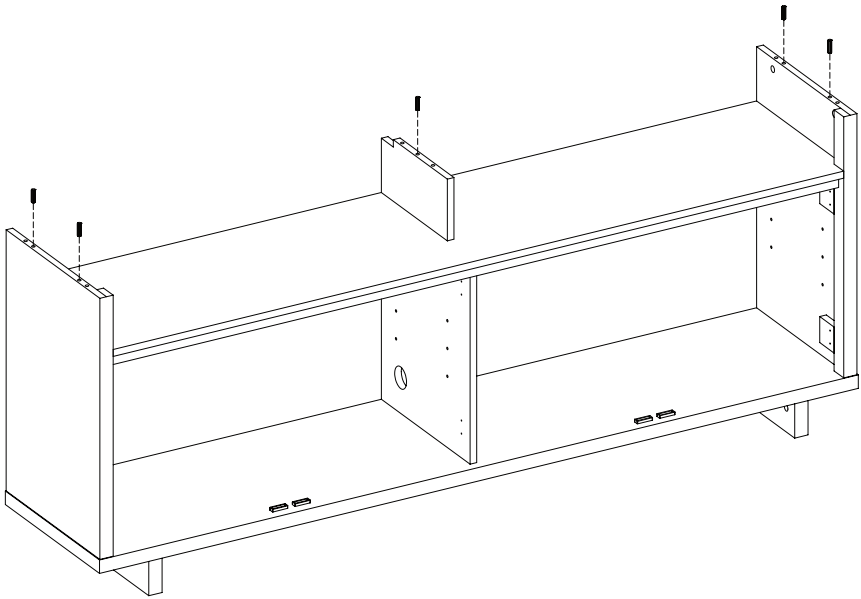

16

BB



[x6]

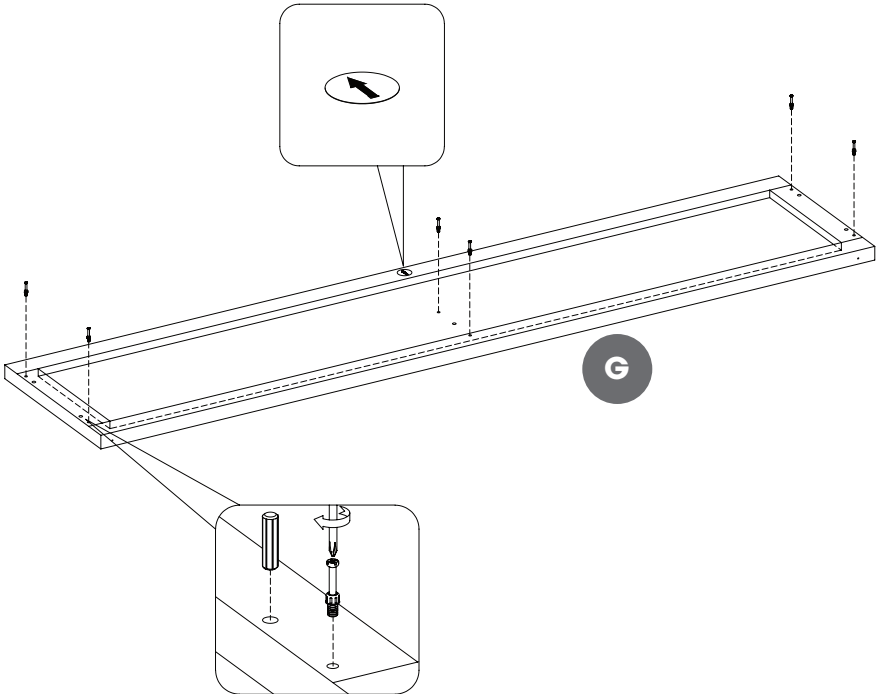

17

EE



[x6]

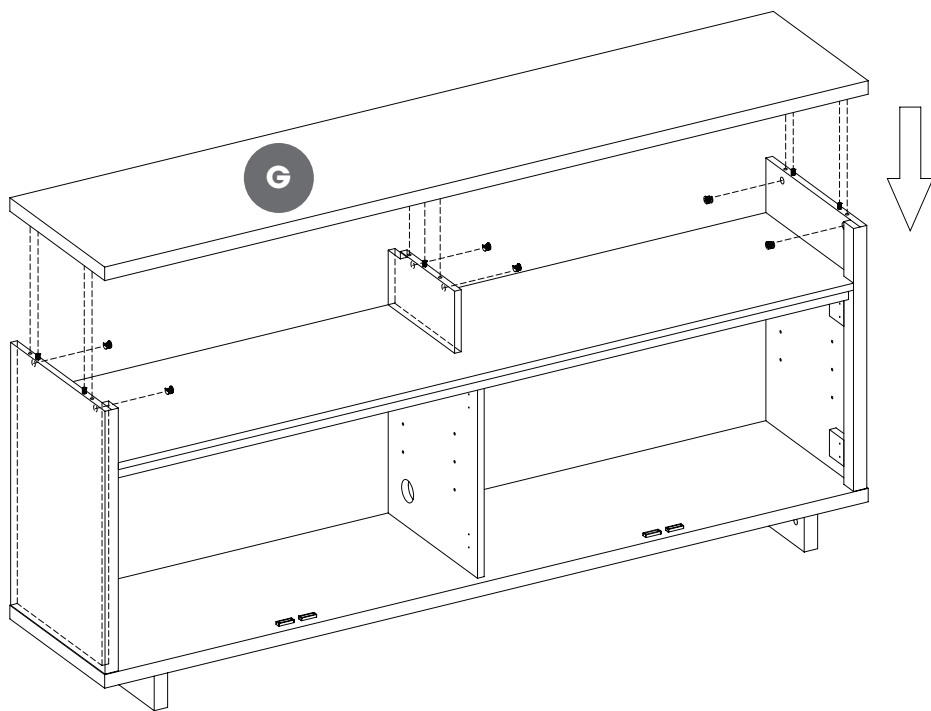
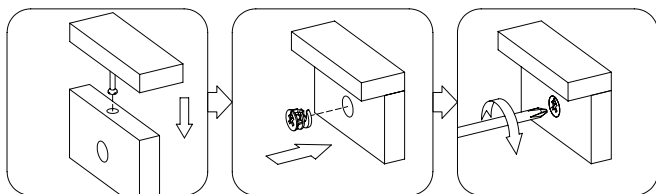

18

HH

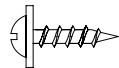

[x2]

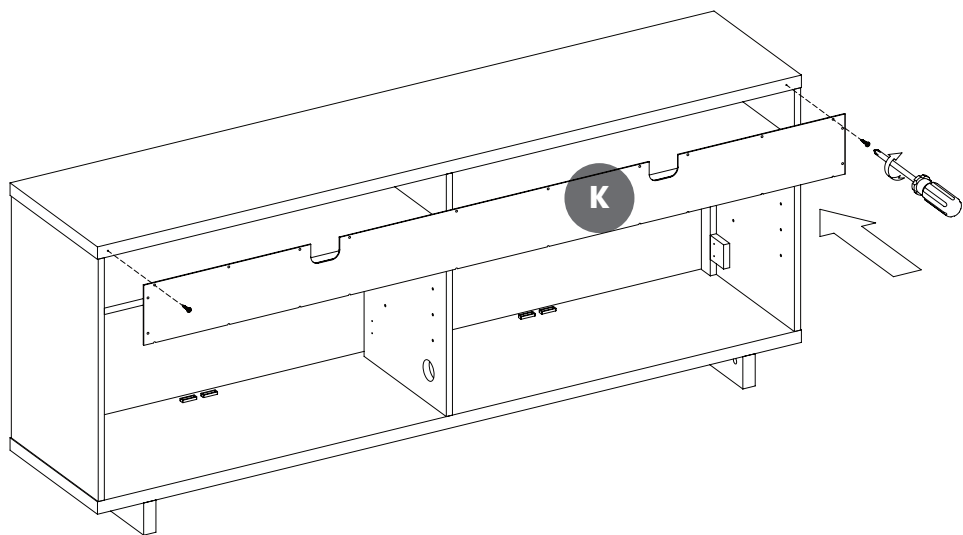

19

HH

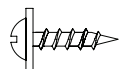

[x12]

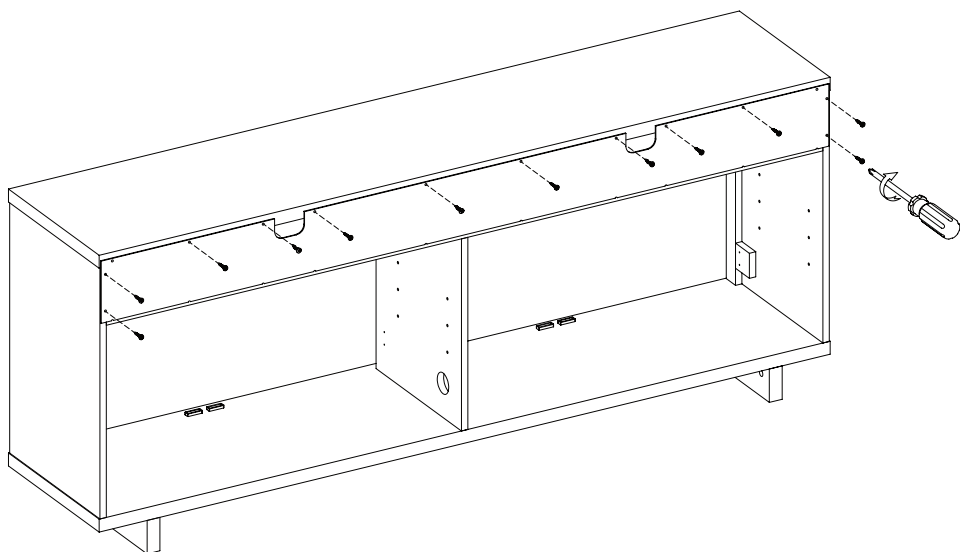

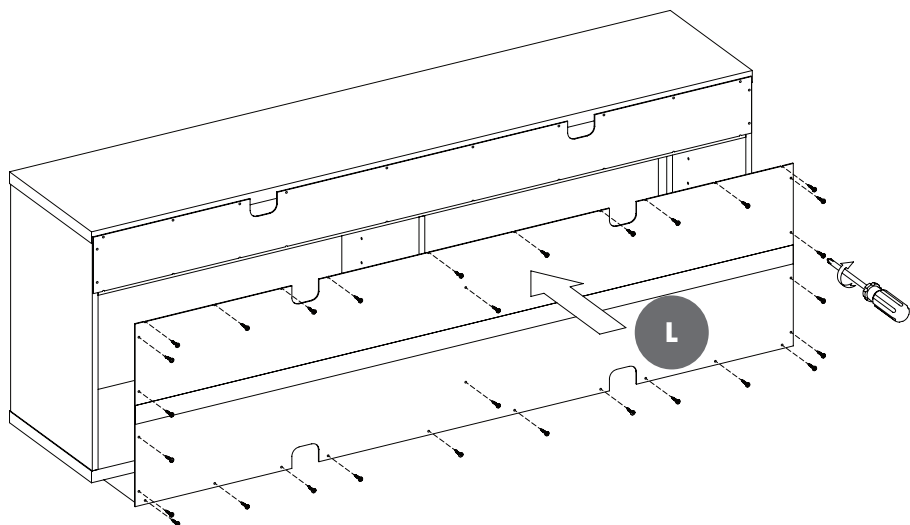
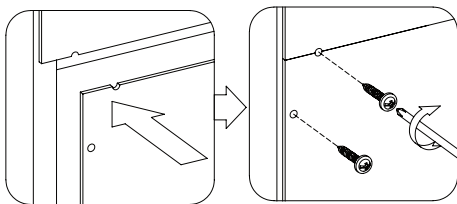
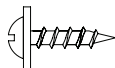

21

NN



[x10]

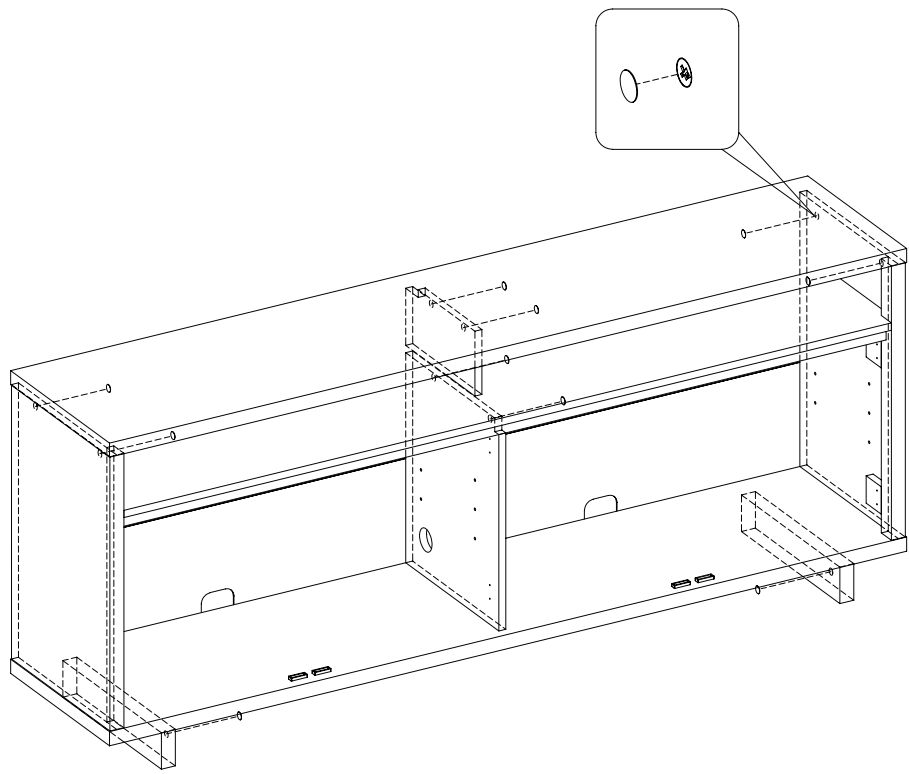

22

AA [x4]



BB [x6]

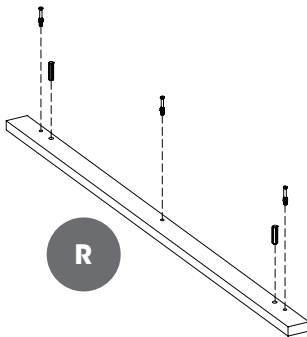
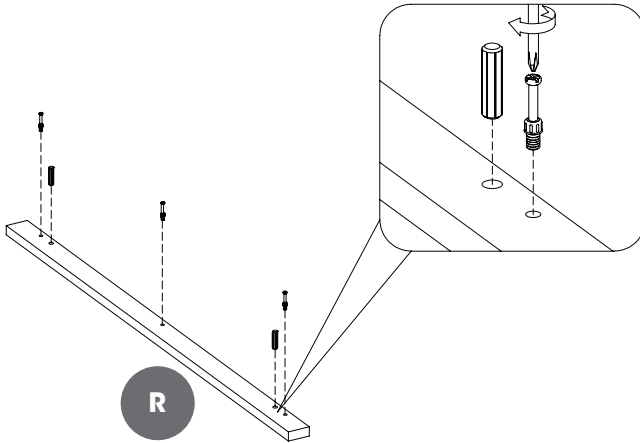

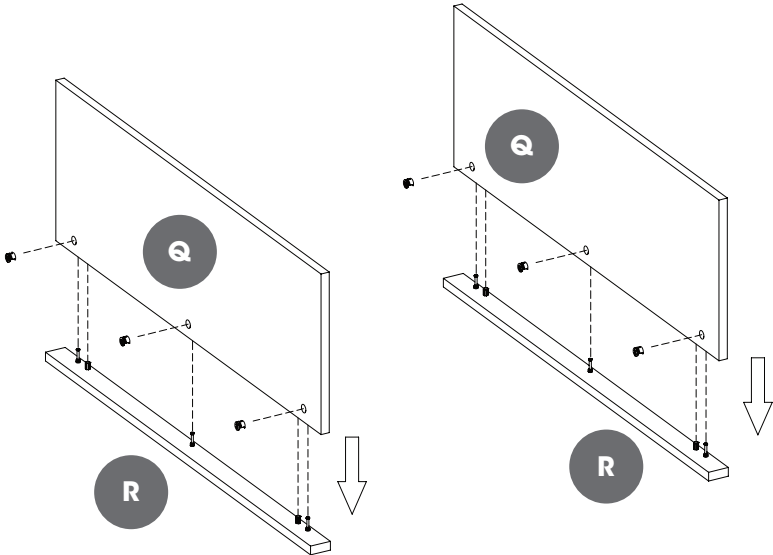
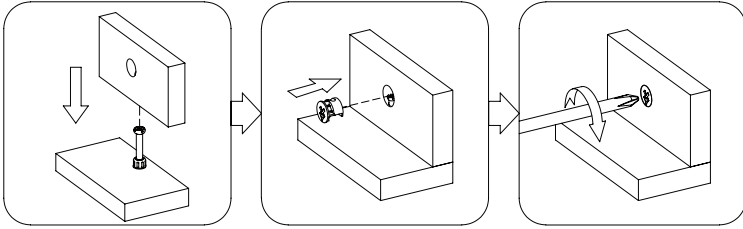

24



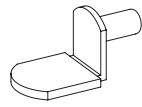

∞

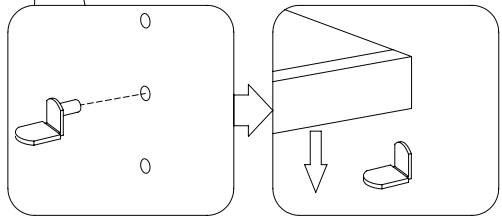
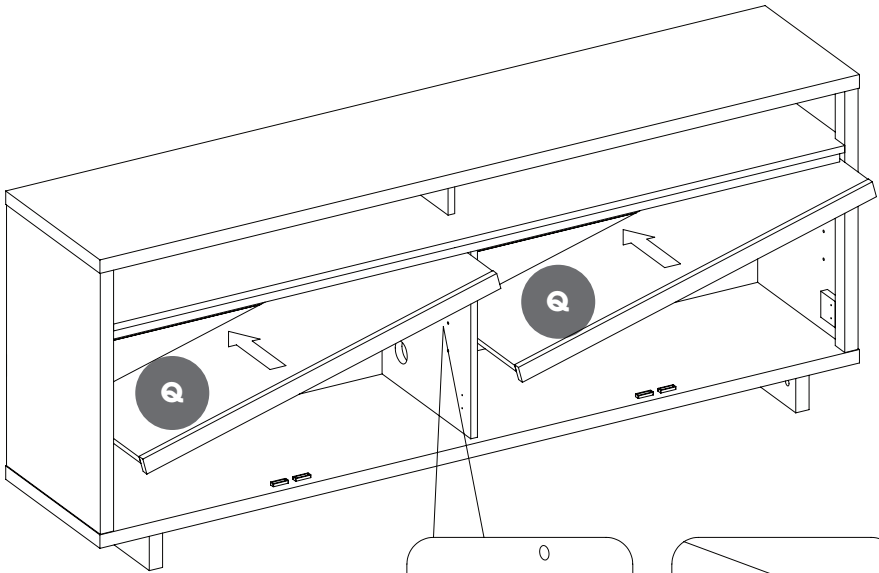

[x8]



25

- II  [x4]
- JJ  [x4]
- KK  [x16]
- LL  [x4]

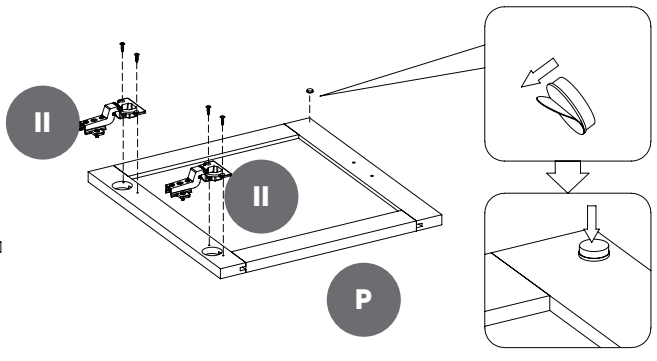
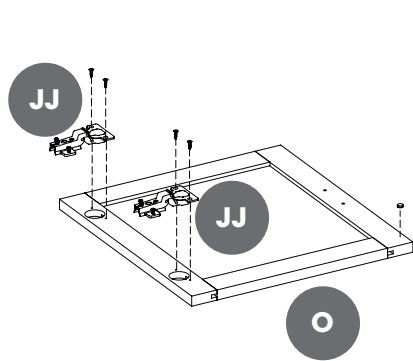
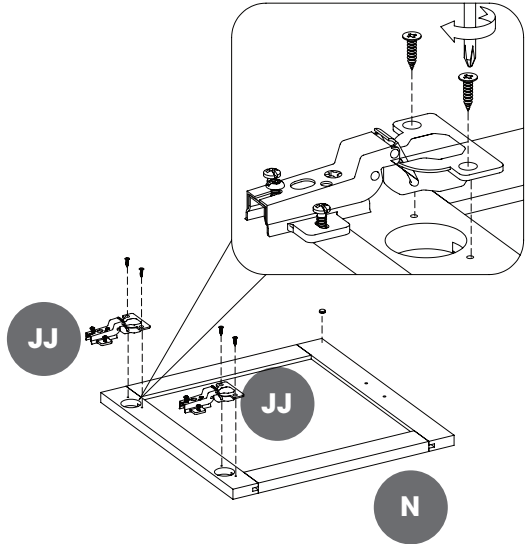
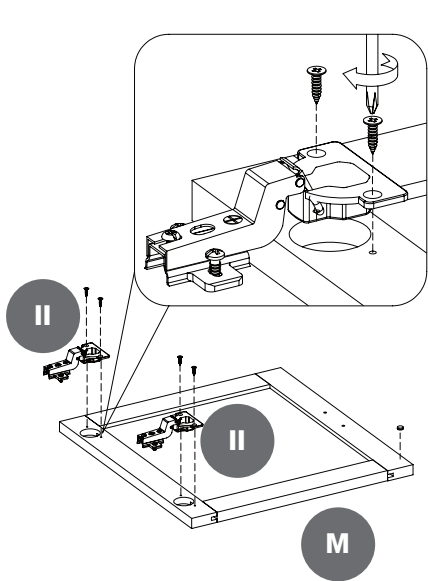

MM

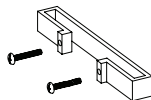

[x4]

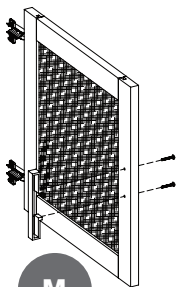

M

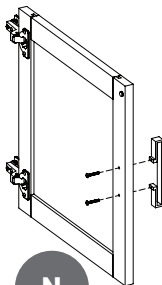

N

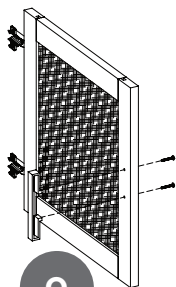

O

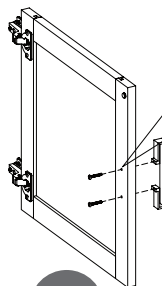

P

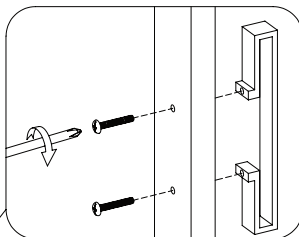

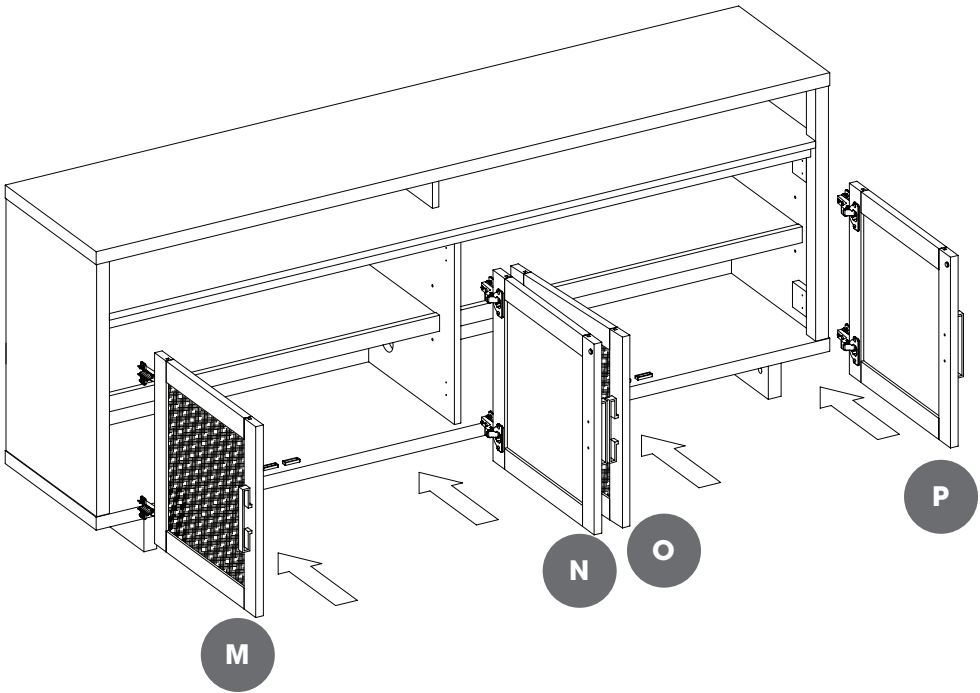
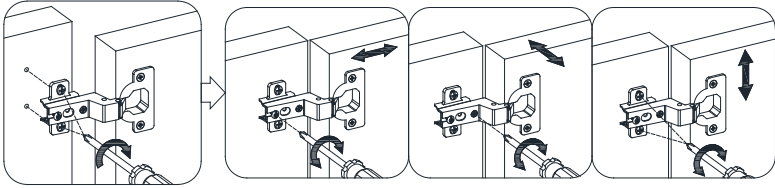

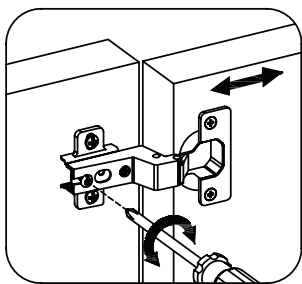

TO ADJUST DOOR FORWARD OR BACKWARD

Loosen the screw and slide the hinge into position, then retighten.

POUR AJUSTER LES PORTES VERS L'AVANT OU L'ARRIÈRE

Dévissez la vis et faites glisser la charnière en position avant de revisser.

PARA AJUSTAR LA PUERTA HACIA ADELANTE O HACIA ATRÁS

Afloje el tornillo y deslice la bisagra a la posición deseada, luego vuelva a apretar.

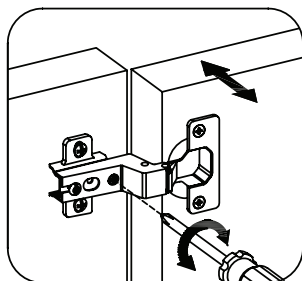

TO ADJUST DOOR RIGHT OR LEFT

Loosen the screw to move the door away from the hinge. Tighten to move the door toward the hinge.

POUR AJUSTER LES PORTES VERS LA GAUCHE OU LA DROITE

Dévissez la vis et éloignez la porte de la charnière. Revissez la vis pour rapprocher la porte de la charnière.

PARA AJUSTAR LA PUERTA A LA DERECHA O A LA IZQUIERDA

Afloje el tornillo para alejar la puerta de la bisagra. Apriete para mover la puerta hacia la bisagra.

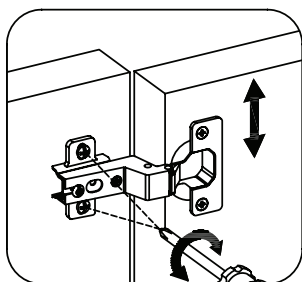

TO ADJUST DOOR UP OR DOWN

Adjust the four screws at the top and bottom of the hinge. Each screw should be loosened or tightened in small increments.

POUR AJUSTER LES PORTES VERS LE HAUT OU LE BAS

Ajustez les quatre vis en haut et en bas de la charnière. Chaque vis doit être dévissée ou revissée petit à petit.

PARA AJUSTAR LA PUERTA HACIA ARRIBA O HACIA ABAJO

Ajuste los cuatro tornillos en la parte superior e inferior de la bisagra. Cada tornillo debe aflojarse o apretarse en pequeños incrementos.

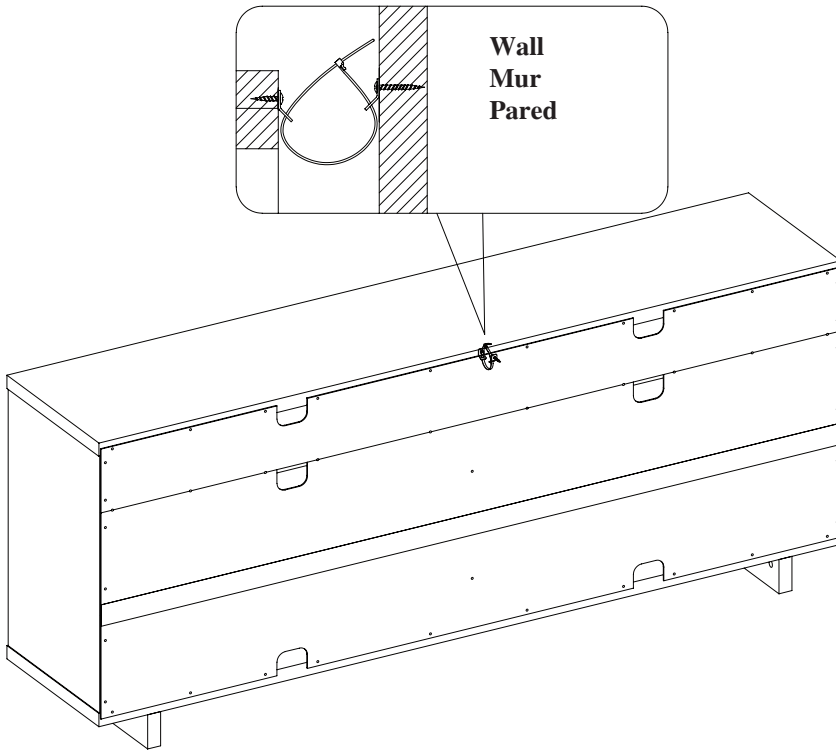

Warning: You must install the tip restraint hardware to help prevent any accidents or damage to the unit. We strongly recommend attaching the tip restraint hardware to a wall stud and your unit. For all other wall types, please visit your local hardware store to obtain the proper hardware.

Avertissement: Il est nécessaire d'installer les pièces d'arrimage anti basculement pour prévenir les accidents ou les dommages à l'unité. Nous vous recommandons fortement de fixer le support avec retenue anti-basculement à un poteau mural et à votre unité. En ce qui concerne tous les autres types de murs, veuillez visiter votre quincaillerie pour obtenir les articles appropriés.

Advertencia: Debe instalar el Herraje contra Caídas para evitar accidentes o que se dañe la unidad. Recomendamos enfáticamente sujetar el extremo de la herramienta de retención a un perno de pared y su unidad. Respecto de todos los demás tipos de pared, vaya a su ferretería local para obtener las herramientas adecuadas.

Care and Maintenance

- Use a soft, clean cloth that will not scratch the surface when dusting.
- Use of furniture polish is not necessary. Should you choose to use polish, test first in an inconspicuous area.
- Using solvents of any kind on your furniture may damage the finish.
- Never use water to clean your furniture as it may cause damage to the finish.
- Always use coasters under beverage glasses and flowerpots.
- Liquid spills should be removed immediately, as it may damage the furniture. Use a soft, clean cloth and blot the spill gently. Avoid rubbing.
- Always use protective pads under hot dishes and plates. Heat can cause chemical changes that may create spotting within the furniture.

Further advice about wood furniture care

It is best to keep your furniture in a climate-controlled environment. Temperature and humidity changes can cause fading, warping, shrinking and splitting of wood. It is advised to keep furniture away from direct sunlight as sun may damage the finish. Proper care and cleaning at home will extend the life of your purchase.

We hope you enjoy your purchase for many years. Thank you for your purchase!

Soin / Entretien

- Lors de l'époussetage, utilisez un chiffon doux et propre qui n'égratigne pas la surface.
- Il n'est pas nécessaire d'utiliser du poli à meuble. Si vous décidez d'utiliser du poli à meuble, veuillez d'abord en faire l'essai dans un endroit moins en évidence.
- L'utilisation de solvant de quelque sorte sur votre ameublement peut endommager le fini.
- Ne jamais utiliser d'eau pour nettoyer votre ameublement car cela peut endommager le fini.
- Utilisez toujours des dessous de verre sous les verres/tasses des breuvages et sous les pots à fleur.
- Tout déversement de liquide doit être enlevé immédiatement car cela peut endommager l'ameublement. Utilisez un chiffon doux et propre et épongez délicatement le déversement. Évitez de frotter.
- Utilisez toujours des tampons protecteurs sous les plats et les assiettes chaudes. La chaleur peut causer des changements chimiques qui peuvent créer des taches sur l'ameublement.

Conseils supplémentaires pour l'entretien de meubles en bois

Il est préférable de garder vos meubles dans un environnement climatisé. Les changements de température et d'humidité peuvent décolorer, déformer, rétracter et fendiller le bois. Il est conseillé de garder les meubles à l'abri de la lumière directe du soleil car cela pourrait endommager le fini. L'entretien et le nettoyage appropriés à domicile prolongeront la vie de votre achat.

Nous espérons que vous apprécierez votre achat pendant de nombreuses années. Nous vous remercions pour votre achat!

Cuidado / Mantenimiento

- Use un paño suave y limpio que no raye la superficie cuando elimine el polvo.
- El uso de cera para muebles no es necesario. Si elige utilizar la cera, realice primero una prueba en un área discreta.
- Usar solventes de cualquier clase en sus muebles puede dañar el acabado.
- Nunca utilice agua para limpiar sus muebles, ya que puede causar daños en el acabado.
- Siempre utilice posavasos para colocar los vasos de bebidas y las macetas.
- Los derrames de líquidos se deben de secar inmediatamente, ya que pueden dañar el mueble. Use un paño suave y limpio y seque el derrame con cuidado. Evite frotar.
- Siempre utilice almohadillas protectoras debajo de los platos y vajillas calientes. El calor puede causar cambios químicos los cuales pueden crear manchas en los muebles.

Consejos adicionales sobre el cuidado de los muebles de madera

Lo mejor es mantener sus muebles en un ambiente con clima controlado. Los cambios de temperatura y humedad pueden hacer que la madera se decolore, se combe, se encoja y se parta. Se aconseja mantener los muebles alejados de la luz solar directa, ya que esta puede dañar el acabado. El cuidado y la limpieza adecuados en casa extenderán la vida útil de su compra.

Esperamos que disfrute de su compra durante muchos años. ¡Gracias por su compra!

When registering your product, be sure to sign up for our updates to receive important service information and helpful tips. We value your privacy and will never share your personal information with other organizations. The information you submit is used only for providing product related services to you.

If you are unable to register your product, please save your proof of purchase for part replacement.

Lorsque vous enregistrez votre produit, assurez-vous de vous inscrire à nos mises à jour afin de recevoir d'importantes informations concernant les services et de précieux conseils. Nous accordons de l'importance à votre vie privée et nous ne communiquerons jamais vos informations personnelles à d'autres organisations. Les informations que vous fournissez sont utilisées uniquement pour vous offrir des services en lien avec les produits.

Si vous n'êtes pas en mesure d'effectuer l'enregistrement, conservez votre preuve d'achat pour le remplacement de pièces.

Cuando registre su producto, asegúrese de suscribirse para recibir actualizaciones importantes sobre el servicio y consejos útiles. Valoramos su privacidad y no compartiremos su información personal con otras organizaciones. Valoramos su privacidad y no compartiremos su información personal con otras organizaciones.

Si no puede registrar su producto, guarde el comprobante de compra para obtener piezas de repuesto.