

# N625P333718W/N625P333719W

Product manual  
Gebrauchsanweisung  
Manuel du produit  
Manual del producto  
Manuale del prodotto

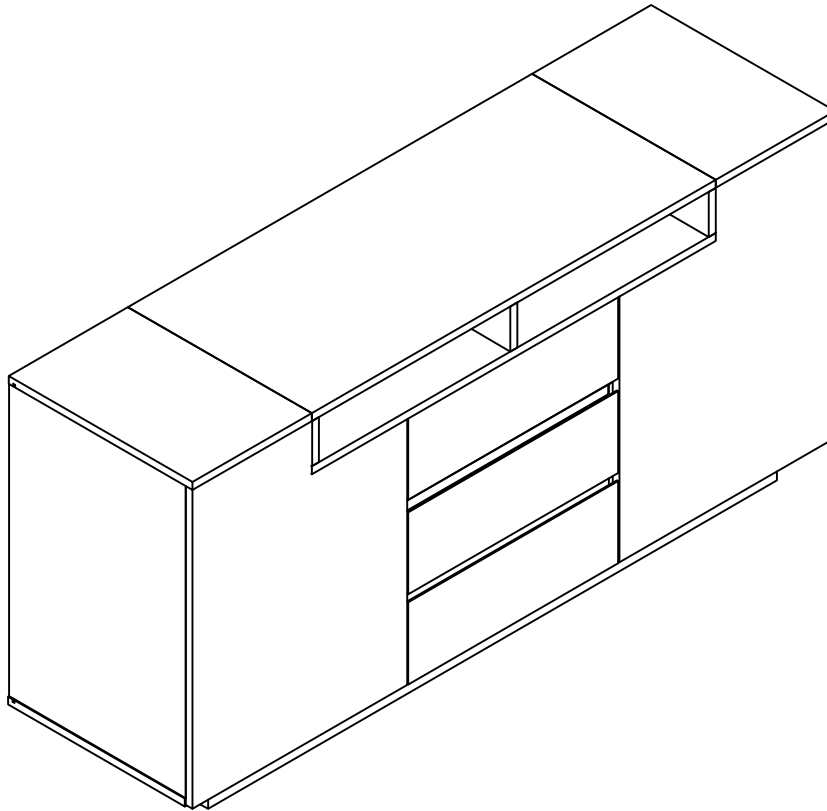

EN:Our product will be delivered to you in 2 packages.The delivery times of these 2 packages may differ, please be patient and thank you for your understanding

FR:Notre produit vous sera livré en 2 colis.Les délais de livraison de ces 2 colis peuvent différer, soyez patient et merci de votre compréhension.

DE:Unser Produkt wird Ihnen in 2 Paketen geliefert.Die Lieferzeiten dieser 2

Paketekönnen abweichen, bitte haben Sie etwas Geduld und vielen Dank für Ihr Verständnis

IT:I nostri prodotti vengono trasportati in due pacchetti. I tempi di consegna dei due pacchetti sono diversi, abbiamo pazienza e vi ringraziamo per la vostra comprensione.

ES:Nuestro producto se entrega en dos paquetes. El tiempo de entrega de estos dos paquetes es diferente. Por favor sea paciente. Gracias por su comprensión.



FR  
Cet appareil,  
ses cordons,  
et batterie  
se recyclent

A DÉPOSER  
EN MAGASIN



A DÉPOSER  
EN DÉCHÈTERIE



OU

Points de collecte sur [www.quefairedesdechets.fr](http://www.quefairedesdechets.fr)  
Privilégiez la réparation ou le don de votre appareil !



2PERS



45 MIN

Tool Required Not Provided

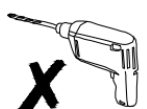
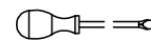



[DE]

Warnung: Lesen Sie diese Anleitung vor dem Zusammenbau bitte vollständig durch. Überprüfen Sie, ob Sie alle auf den Seiten aufgeführten Komponenten und Werkzeuge haben. Bewahren Sie die Anleitung zum späteren Nachschlagen auf. Teile des Zusammenbaus lassen sich mit 2 Personen leichter durchführen. Suchen Sie bei Bedarf professionelle Hilfe.

Warnung: Legen Sie alle Teile auf eine ebene Fläche. Legen Sie eine weiche Decke oder Ähnliches darunter, um sie vor Kratzern oder Flecken zu schützen. Vermeiden Sie es, Komponenten über den Boden zu ziehen oder zu schieben.

sind und um Unfälle zu vermeiden. Wenn Teile fehlen, kaputt, beschädigt oder abgenutzt sind, verwenden Sie das Produkt nicht weiter, bis es mit vom Hersteller autorisierten Teilen repariert wurde.

Warnung: Lassen Sie Kinder nicht auf die Möbel klettern, da dies zum Umkippen und zu schweren Verletzungen führen kann. Bauen Sie die Möbel außerhalb der Reichweite von Kindern zusammen.

Warnung: Stellen Sie die Möbel nicht in die Nähe von Feuerquellen oder heißen Gegenständen, um Brandgefahr zu vermeiden.

Warnung: Reinigen Sie die Möbel mit einem feuchten Tuch oder Alkohol. Verwenden Sie keine Reinigungsmittel mit ätzenden Chemikalien.

Warnung: Dieses Produkt ist mit einer Kippschutzvorrichtung ausgestattet. Bitte installieren Sie diese Vorrichtung unbedingt, um unnötige Verletzungen durch Umkippen zu vermeiden.

[EN]

Warning: Please read these instructions fully before starting assembly. Check you have all the components and tools listed on pages. Keep the instructions for later reference. Parts of the assembly will be easier with 2 people. Seek professional assistance if necessary.

Warning: Please place all parts on a flat surface. Place a soft blanket or similar underneath to protect against scratches or stains. Avoid dragging or sliding components across the floor.

Warning: Regularly check all fittings and fastenings to ensure they are secure and to prevent accidents. If any parts are missing, broken, damaged, or worn, discontinue use of the product until repairs have been made using factory authorized parts.

Warning: Do not allow children to climb on the furniture as this may result in tipping and serious personal injury. Assemble the furniture away from the reach of children.

Warning: Do not place furniture close to fire sources or high-temperature objects to avoid the risk of fire. Do not place furniture in damp environments to prevent material damage.

Warning: Clean furniture with a damp cloth or alcohol, avoid using cleaning agents containing corrosive chemicals.

Warning: This product is equipped with an anti-tilt device. Please be sure to install this device to prevent unnecessary injuries caused by tipping.

[FR]

Avertissement : Veuillez lire attentivement ces instructions avant de commencer l'assemblage. Vérifiez que vous disposez de tous les composants et outils répertoriés sur les pages. Conservez les instructions pour référence ultérieure. Certaines parties de l'assemblage seront plus faciles à 2 personnes. Demandez l'aide d'un professionnel si nécessaire.

Avertissement : Veuillez placer toutes les pièces sur une surface plane. Placez une couverture douce ou similaire en dessous pour les protéger des rayures ou des taches. Évitez de faire glisser les composants sur le sol.

Avertissement : Vérifiez régulièrement tous les raccords et fixations pour vous assurer qu'ils sont bien fixés et pour éviter les accidents. Si des pièces manquent, sont cassées, endommagées ou usées, cessez d'utiliser le produit jusqu'à ce que des réparations aient été effectuées à l'aide de pièces autorisées par l'usine.

Avertissement : Ne laissez pas les enfants grimper sur les meubles car cela pourrait entraîner un basculement et des blessures graves. Assemblez les meubles hors de portée des enfants.

Avertissement : Ne placez pas les meubles à proximité de sources de feu ou d'objets à haute température pour éviter tout risque d'incendie.

Avertissement : Nettoyez les meubles avec un chiffon humide ou de l'alcool, évitez d'utiliser des produits de nettoyage contenant des produits chimiques corrosifs.

Avertissement : Ce produit est équipé d'un dispositif anti-basculement. Assurez-vous d'installer ce dispositif pour éviter les blessures inutiles causées par un basculement.

[IT]

Attenzione: leggere attentamente queste istruzioni prima di iniziare il montaggio. Verificare di avere tutti i componenti e gli strumenti elencati nelle pagine. Conservare le istruzioni per riferimento futuro. Alcune parti del montaggio saranno più facili con 2 persone. Se necessario, chiedere assistenza professionale.

Attenzione: posizionare tutte le parti su una superficie piana. Posizionare una coperta morbida o simile sotto per proteggere da graffi o macchie. Evitare di trascinare o far scivolare i componenti sul pavimento.

Attenzione: controllare regolarmente tutti i raccordi e i dispositivi di fissaggio per assicurarsi che siano sicuri e per prevenire incidenti. Se alcune parti sono mancanti, rotte, danneggiate o usurate, interrompere l'uso del prodotto fino a quando non siano state eseguite le riparazioni utilizzando parti autorizzate dalla fabbrica.

Attenzione: non consentire ai bambini di arrampicarsi sui mobili poiché ciò potrebbe causare ribaltamenti e gravi lesioni personali. Montare i mobili lontano dalla portata dei bambini.

Attenzione: non posizionare i mobili vicino a fonti di fuoco o oggetti ad alta temperatura per evitare il rischio di incendio.

Attenzione: pulire i mobili con un panno umido o alcol, evitare di utilizzare detergenti contenenti sostanze chimiche corrosive.

Attenzione: questo prodotto è dotato di un dispositivo antiribaltamento. Assicurarsi di installare questo dispositivo per prevenire lesioni inutili causate dal ribaltamento.

[ES]

Advertencia: Lea estas instrucciones completamente antes de comenzar el montaje. Compruebe que tiene todos los componentes y herramientas que se enumeran en las páginas. Conserve las instrucciones para consultarlas más adelante. El montaje de algunas partes será más sencillo con 2 personas. Busque ayuda profesional si es necesario.

Advertencia: Coloque todas las piezas sobre una superficie plana. Coloque una manta suave o algo similar debajo para protegerlas de rayones o manchas. Evite arrastrar o deslizar los componentes por el piso.

Advertencia: Verifique regularmente todos los accesorios y fijaciones para asegurarse de que estén seguros y evitar accidentes. Si falta alguna pieza, está rota, dañada o desgastada, deje de usar el producto hasta que se hayan realizado las reparaciones con piezas autorizadas de fábrica.

Advertencia: No permita que los niños se suban a los muebles, ya que esto puede provocar que se vuelquen y lesiones personales graves. Monte los muebles fuera del alcance de los niños.



Advertencia: No coloque los muebles cerca de fuentes de fuego u objetos de alta temperatura para evitar el riesgo de incendio.

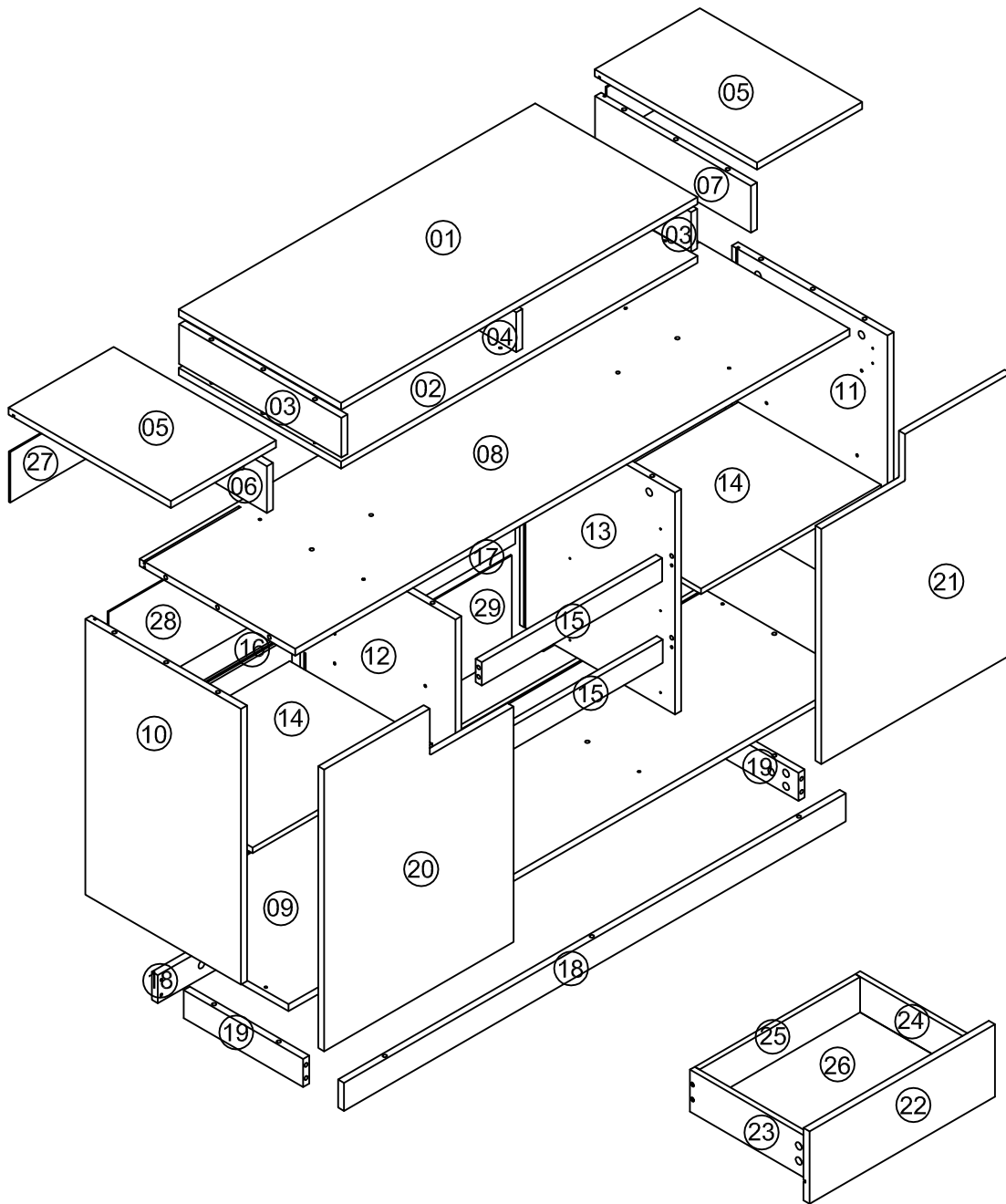

Advertencia: Limpie los muebles con un paño húmedo o alcohol, evite usar agentes de limpieza que contengan químicos corrosivos.



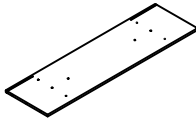
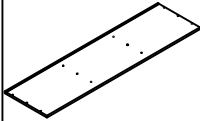

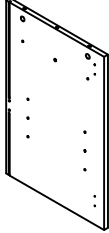
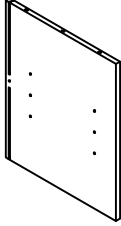
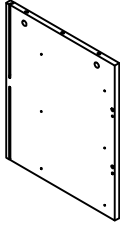
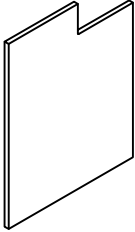
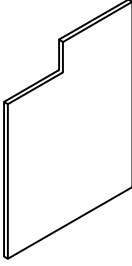

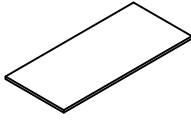
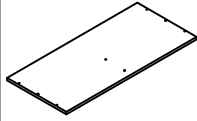
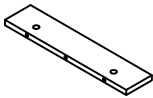
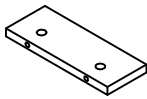
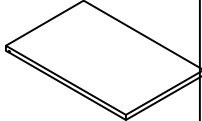
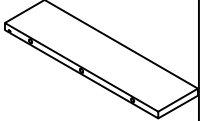
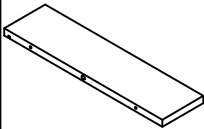
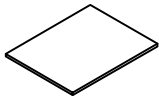
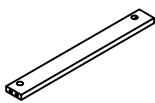
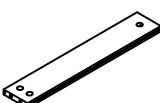
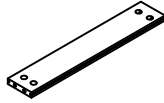
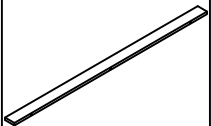
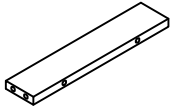
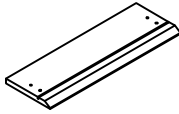
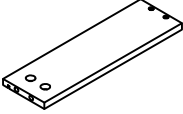
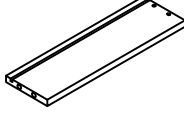

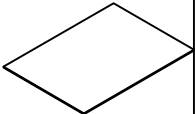
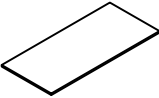
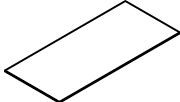
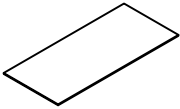
Advertencia: Este producto está equipado con un dispositivo antivuelco. Asegúrese de instalar este dispositivo para evitar lesiones innecesarias causadas por vuelcos.

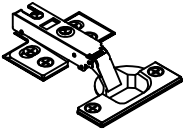
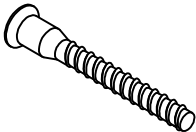

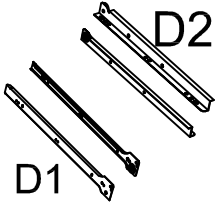
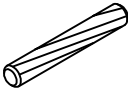
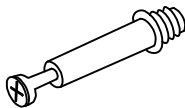
X3

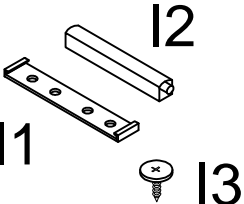
					
⑧ X1	⑨ X1	⑩ X1	⑪ X1	⑫ X1	⑬ X1
					
⑳ X1	㉑ X1				

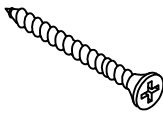
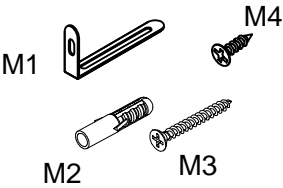
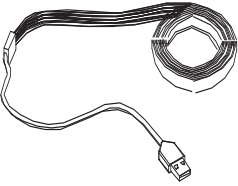
					
① X1	② X1	③ X2	④ X1	⑤ X2	⑥ X1
					
⑦ X1	⑭ X2	⑮ X2	⑯ X2	⑰ X1	⑱ X2
					
⑲ X2	⑳ X3	㉓ X3	㉔ X3	㉕ X3	㉖ X3
					
㉗ X2	㉘ X4	㉙ X2			

<p><b>A</b> 4pcs</p> 	<p><b>B</b> 18pcs</p> 	<p><b>C</b> 8pcs</p> 	<p><b>D</b> 3pcs</p> 
	<p>Φ5*40</p>		<p>300mm</p>
<p><b>E</b> 22pcs</p> 	<p><b>F</b> 66pcs</p> 	<p><b>G</b> 66pcs</p> 	<p><b>H</b> 12pcs</p> 
<p>Φ8*40</p>		<p>Φ15*12</p>	
<p><b>I</b> 8pcs</p> 	<p><b>J</b> 2pcs</p> 	<p><b>K</b> 76pcs</p> 	<p><b>L</b> 12pcs</p> 
	<p>Φ6*20</p>	<p>Φ3.5*14</p>	<p>Φ3.5*35</p>
<p><b>M</b> 2pcs</p> 	<p><b>N</b> 1pc</p> 	<p><b>O</b> 66pcs</p> 	
	<p>800mm</p>		

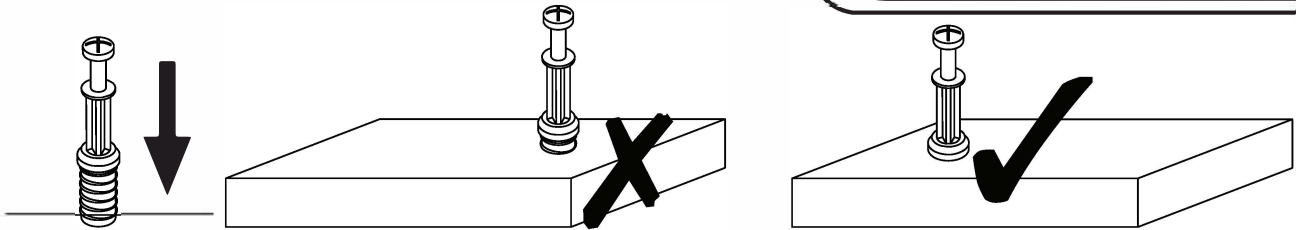

**EN\_QUICKFIT:** Tighten quickfit until shoulder is flush with panel. Do not overtighten or undertighten.

**FR\_RACCORD RAPIDE:** Faites serrer le raccord rapide jusqu'à ce que l'épaulement soit parfaitement encastré dans le panneau. Il ne faut ni trop serrer ni insuffisamment serrer.

**ES\_QUICKFIT:** Apriete quickfit hasta que el hombro se descargue con el panel. NO lo sobreapriete ni lo apriete poco.

**DE\_QUICKFIT:** Ziehen Sie den Quickfit fest, bis die Schulter mit der Platte bündig ist. Bitte nicht zu fest oder zu schwach anziehen.

**IT\_MONTAGGIO RAPIDO:** Stringere il montaggio rapido fino a quando la spalla è a filo con il pannello, non stringere troppo o troppo poco.

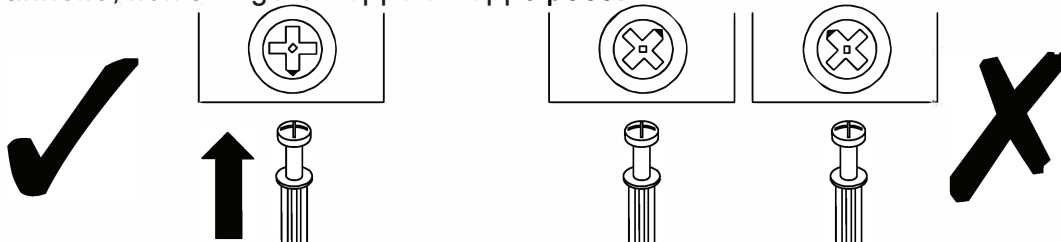

**EN\_CAM LOCK:** When fitting cam lock, ensure starting position is correct before you insert connecting quickfit.

**FR\_SERRURE BATTEUSE:** Avant d'insérer la serrure batteuse, veillez à la bonne orientation avant d'insérer le raccord rapide.

**ES\_CIERRE DE LA CÁMARA:** Cuando instale el cierre de la cámara, asegúrese de que la posición de inicio es correcta antes de que inserte el quickfit conector.

**DE\_CAM-LOCK:** Achten Sie bei der Montage des Cam-Locks auf die richtige Ausgangsposition, bevor Sie den Quickfit einsetzen.

**IT\_BLOCCAGGIO A CAMMA:** Quando si monta il bloccaggio a camma, assicurarsi che la posizione iniziale sia corretta prima di inserire il montaggio rapido di collegamento.

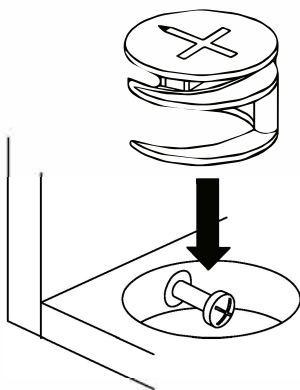

**EN\_Quickfit head** should be in the centre of the cam lock when the two panels are joined.

Cam lock should be inserted before quickfit.

**FR\_**Lorsque les deux panneaux sont assemblés, la tête du raccord rapide doit reposer au centre de la serrure batteuse. Il faut insérer la serrure batteuse avant le raccord rapide.

**ES\_**El cabezal del quickfit debe estar en el centro del cierre de la cámara cuando se unan los dos paneles.

Se debe insertar el cierre de la cámara antes que el quickfit.

**DE\_**Der Quickfit-Kopf sollte sich in der Mitte des Cam-Locks befinden, wenn die beiden Platten zusammengefügt sind. Der Cam-Lock sollte vor dem Quickfit eingesetzt werden.

**IT\_**La testa del montaggio rapido deve trovarsi al centro del bloccaggio a camma quando i due pannelli sono uniti.

Il Bloccaggio a Camma deve essere inserito prima del montaggio rapido.

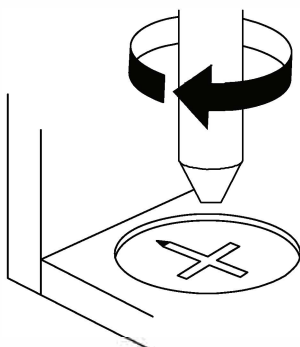

**EN\_**Turn cam lock clockwise to tighten.

**FR\_**Faites tourner la serrure batteuse dans le sens des aiguilles d'une montre pour la resserrer.

**ES\_**Gire el cierre de la cámara en sentido horario para apretarlo.

**DE\_**Drehen Sie den Cam-Lock im Uhrzeigersinn, um ihn festzuziehen.

**IT\_**Ruotare il bloccaggio a camma in senso orario per stringere.

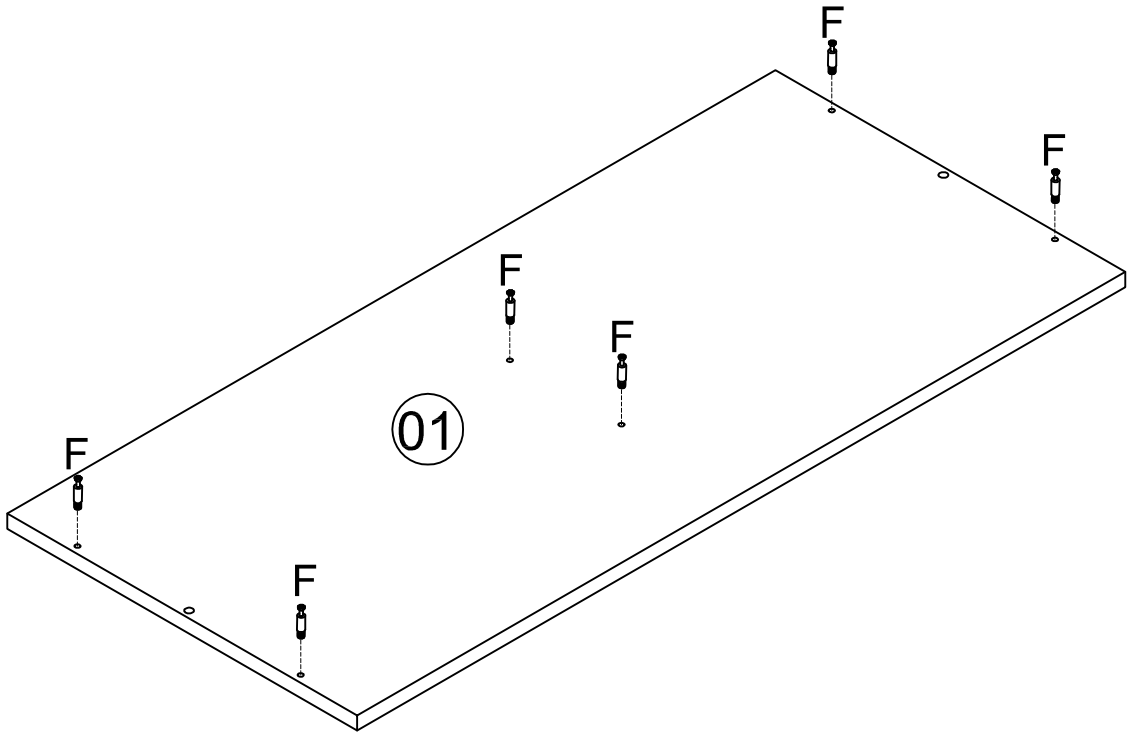
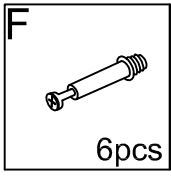

01

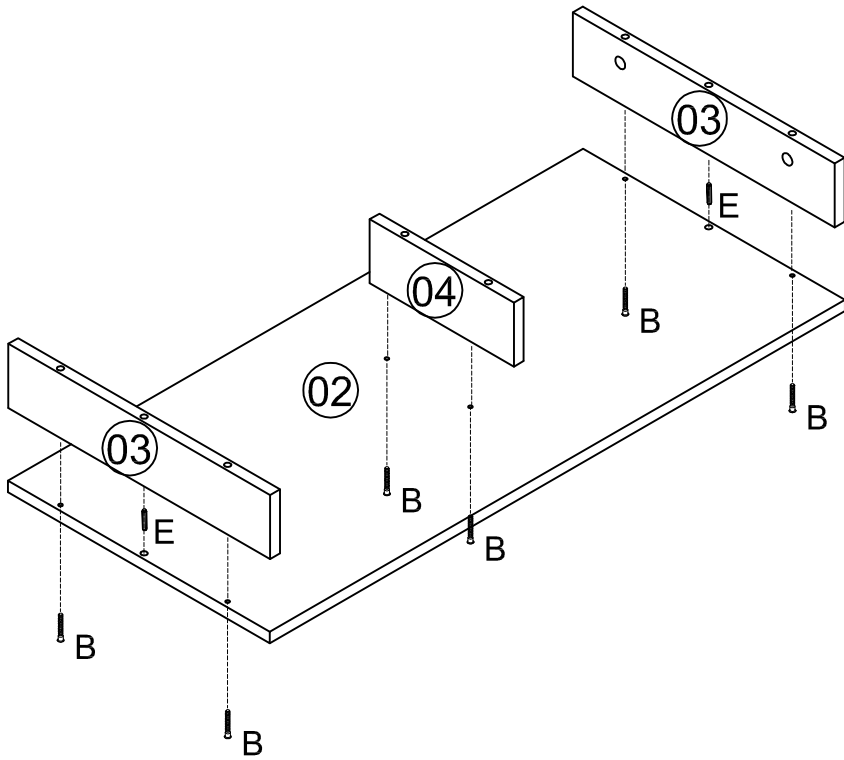
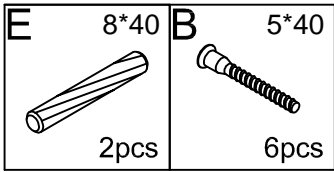

02



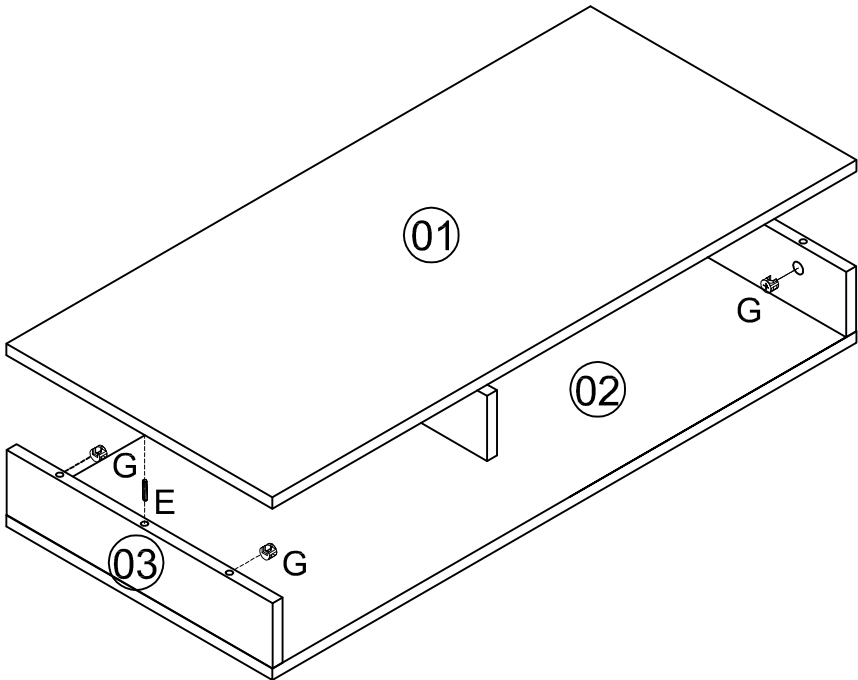

# 03

<b>G</b>  6pcs	<b>E</b> $\Phi 8 \times 40$  2pcs
--	---

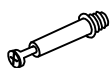

# 04

<b>F</b>  10pcs	<b>D1</b>  3pcs	<b>K</b> 3.5*14  12pcs
--	--	---

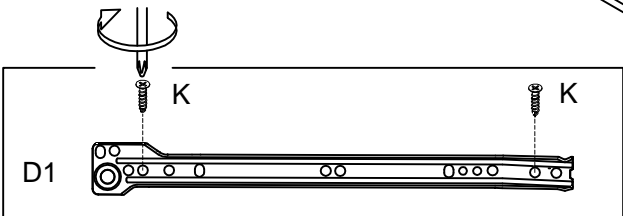
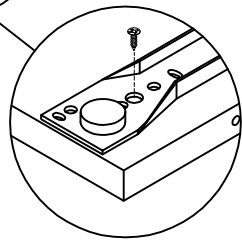
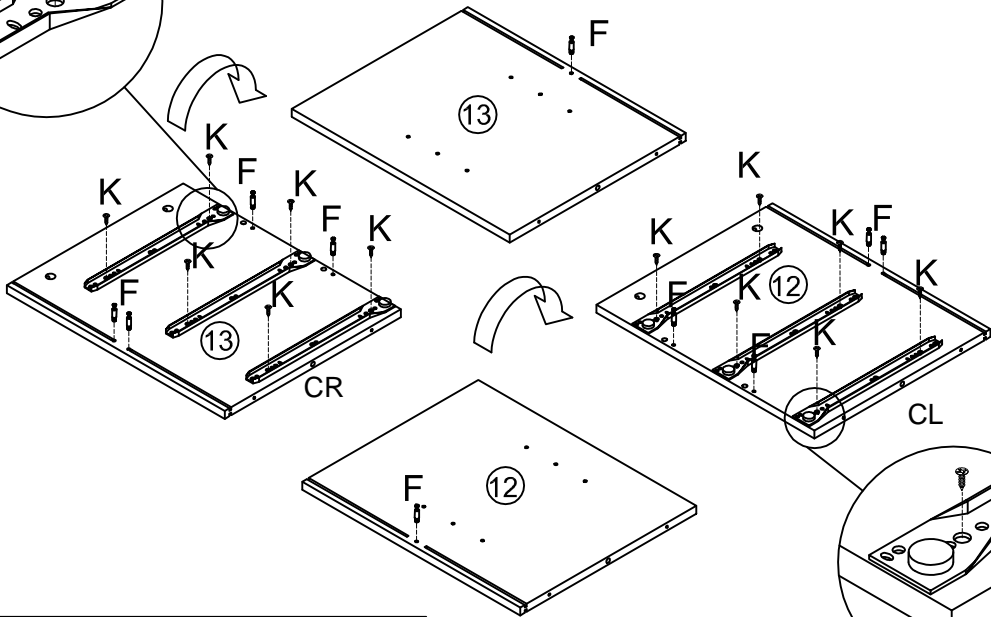
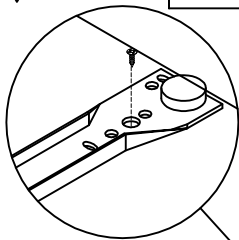

05

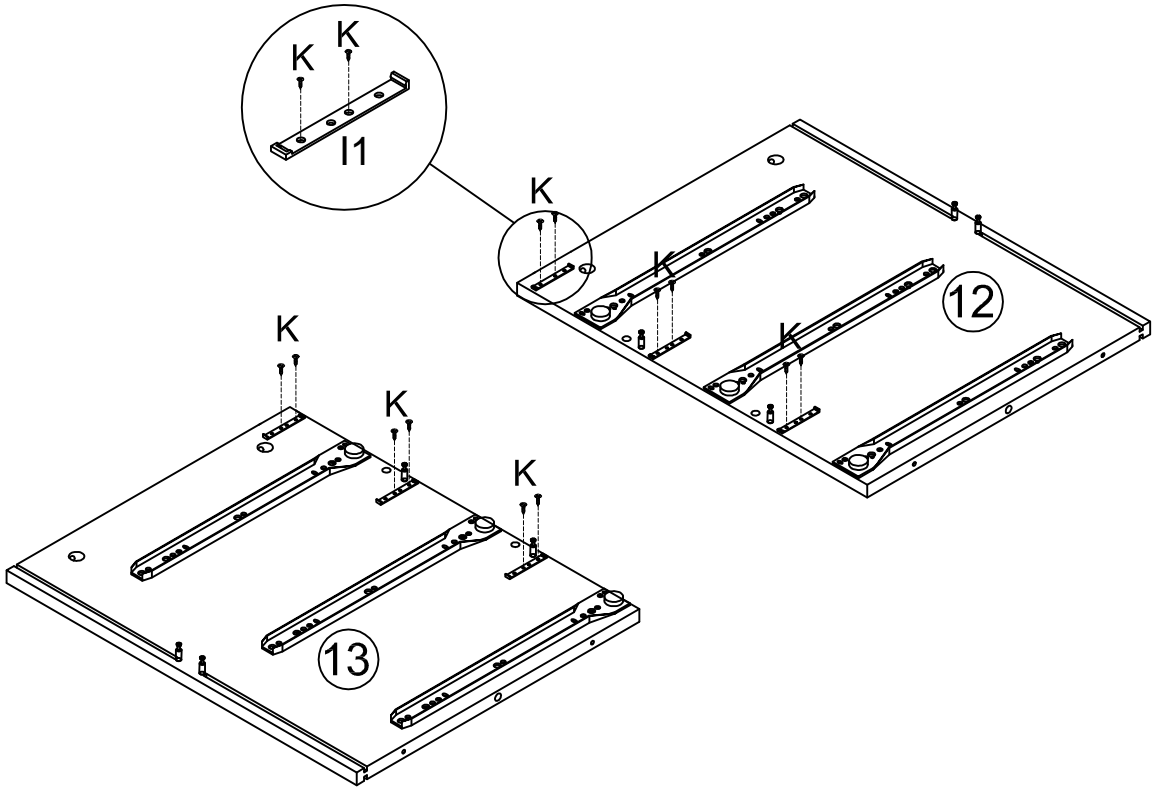
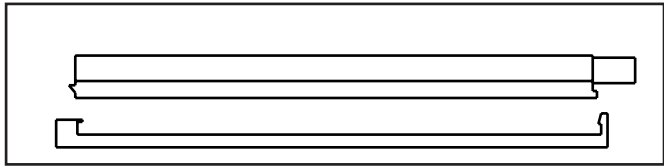
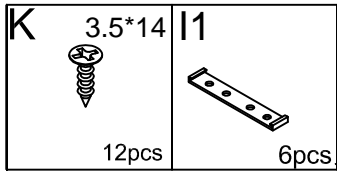

06

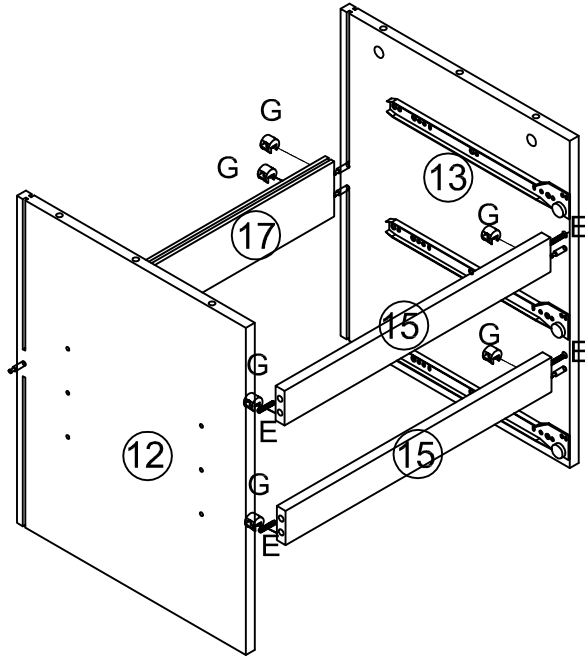
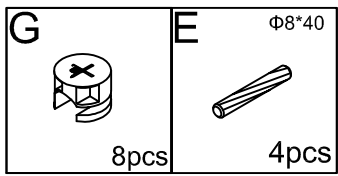

07

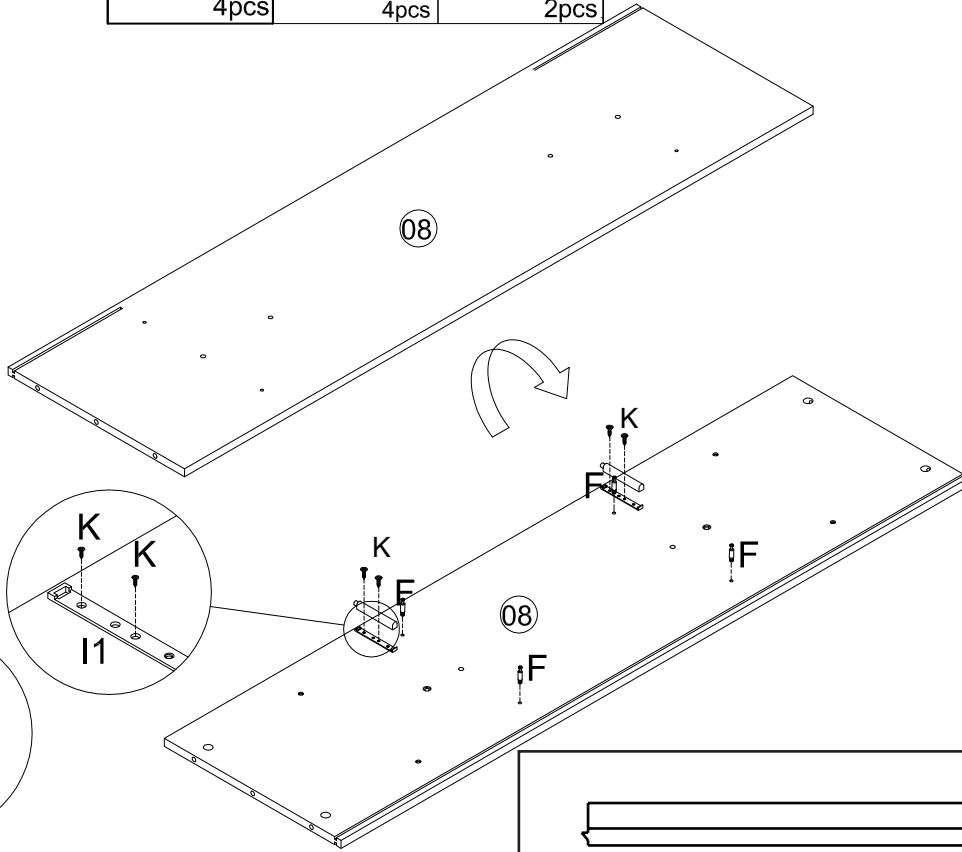
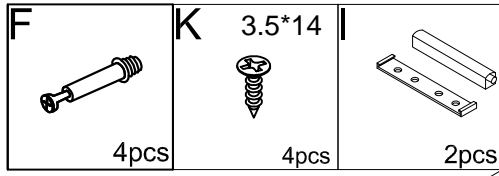

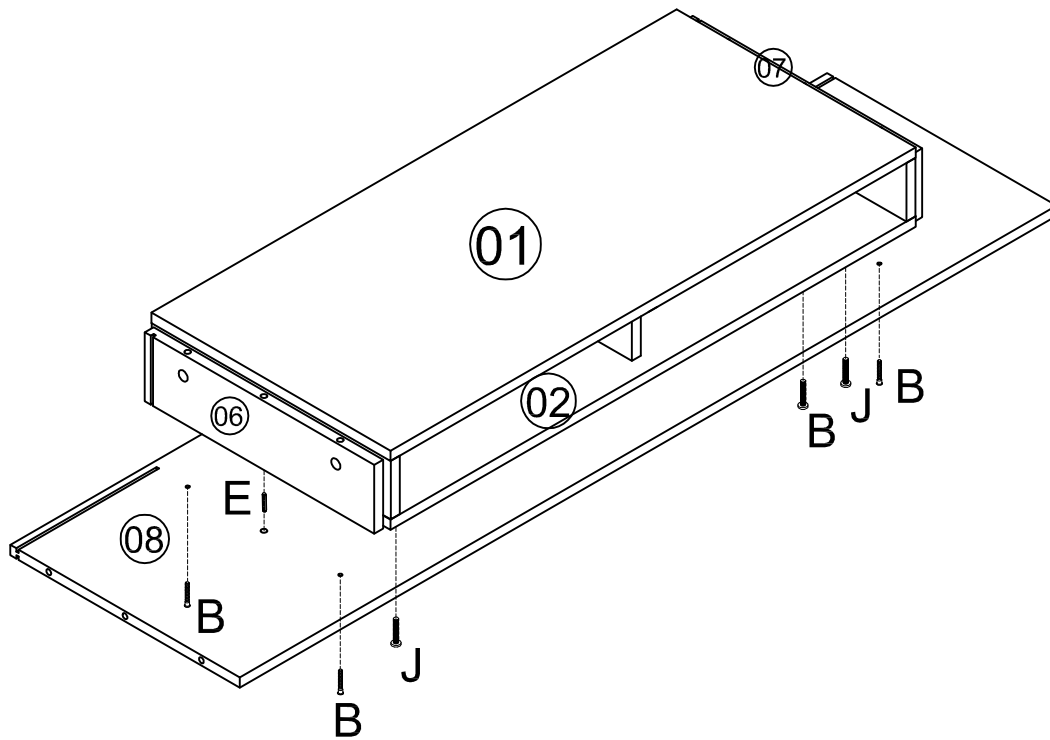
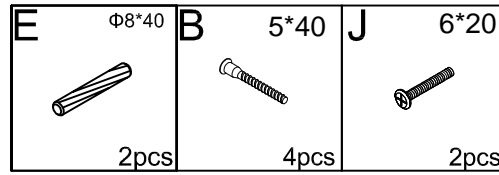

08





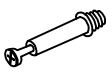

11

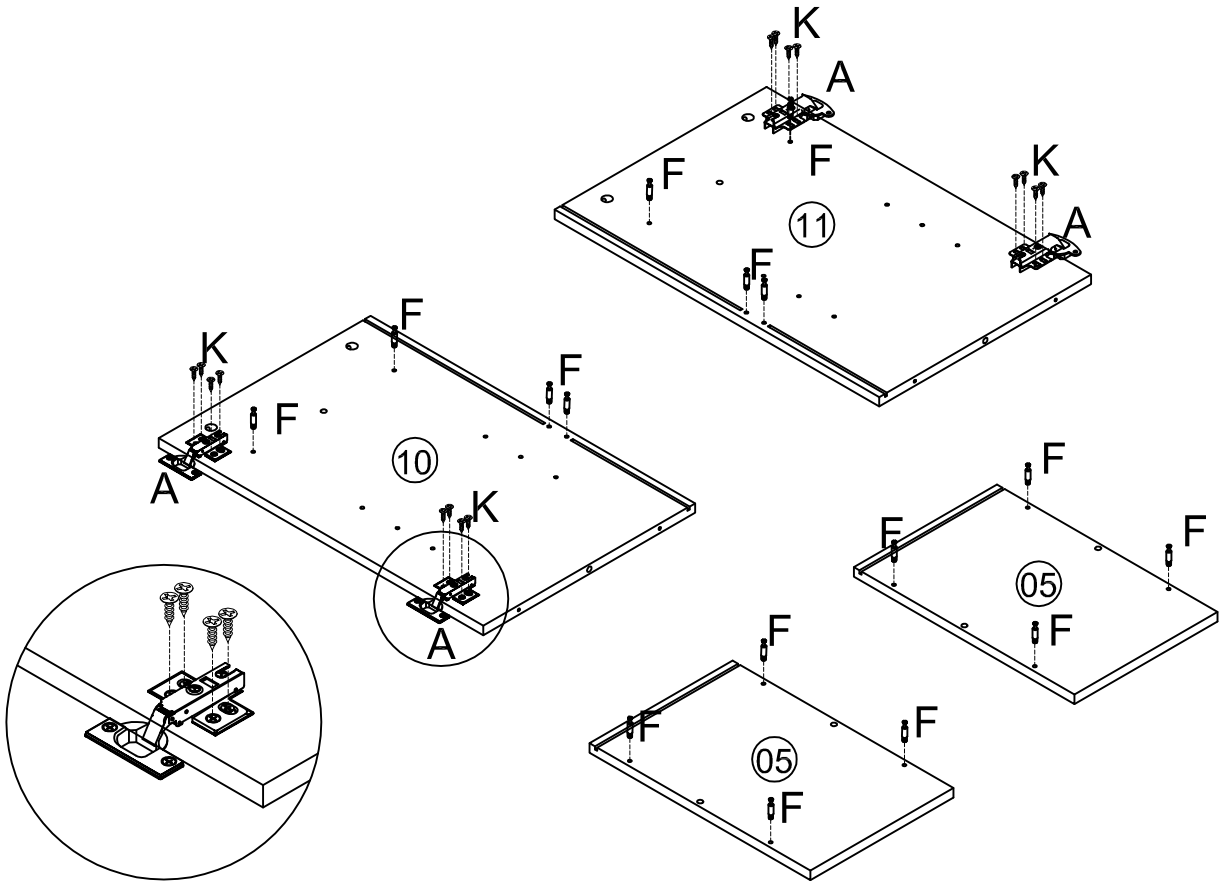
<b>K</b> 3.5*14  16pcs	<b>F</b>  16pcs	<b>A</b>  4pcs
--	---	--



12

<b>G</b>  8pcs	<b>E</b> $\Phi 8 \times 40$  2pcs
---	--

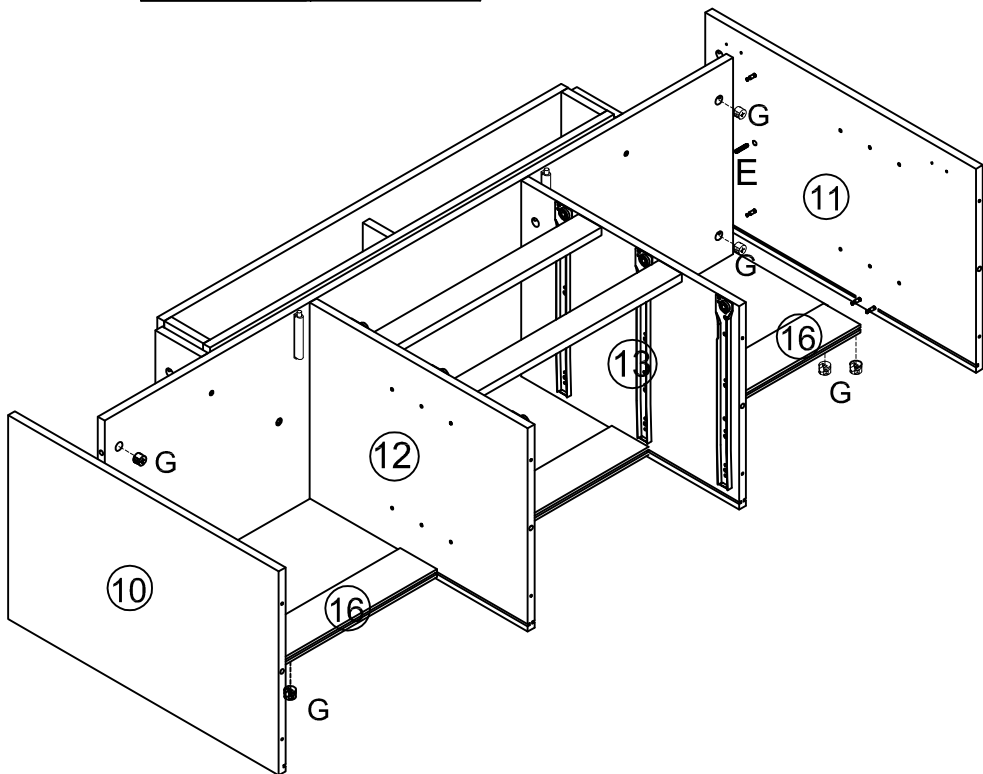

13

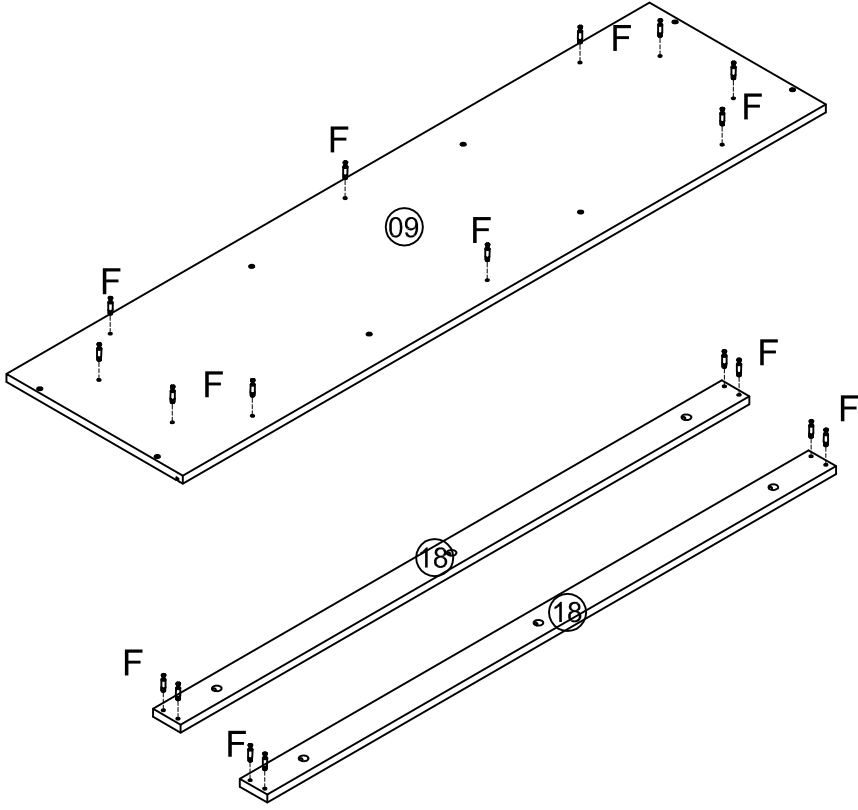
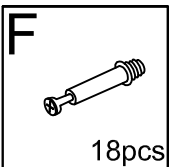

14

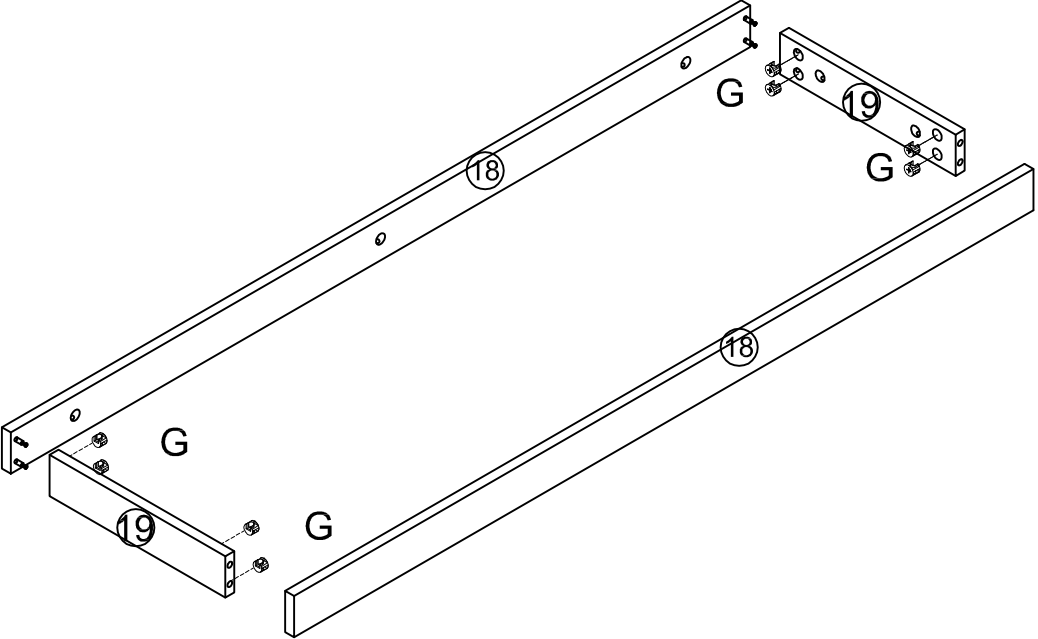
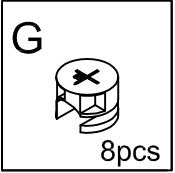

15

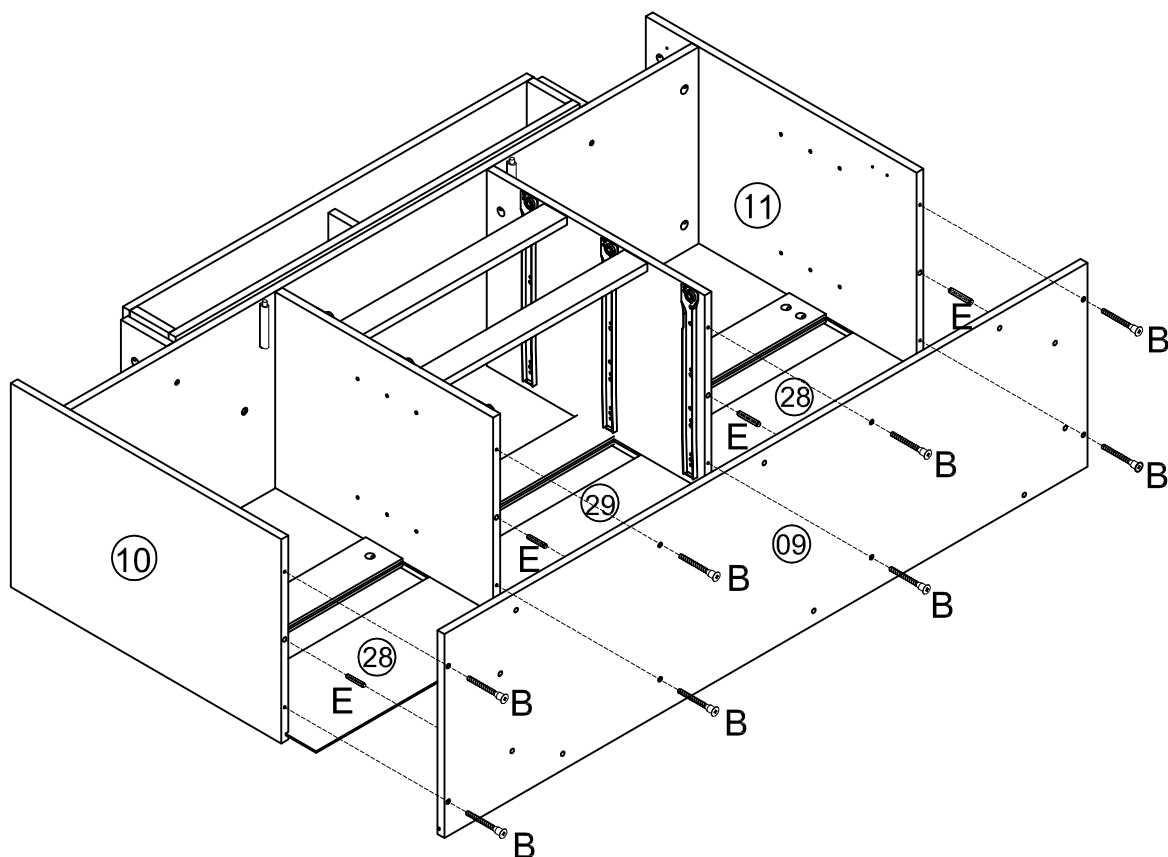
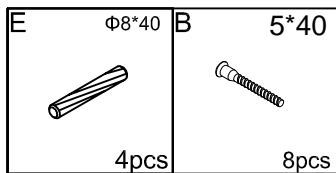

16

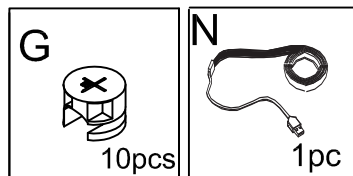

EN: Tearoff the back tape  
 FR: Déchirer le ruban adhésif arrière  
 DE: Reiß das hintere Band ab  
 IT: Rimuovere il nastro posteriore  
 ES: Arrancar la cinta trasera

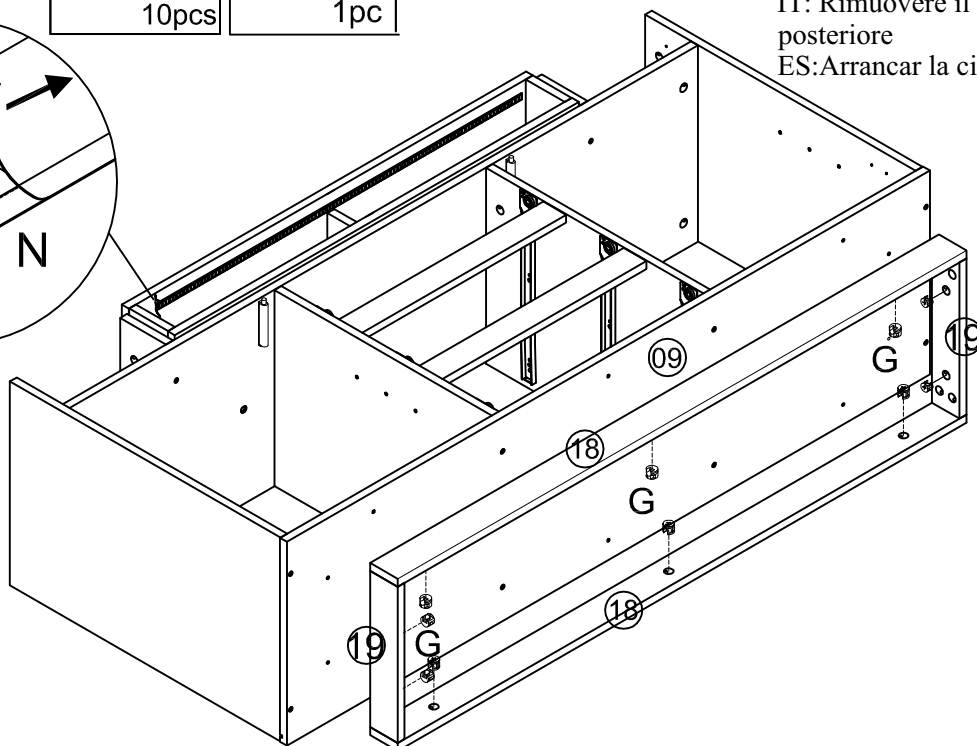
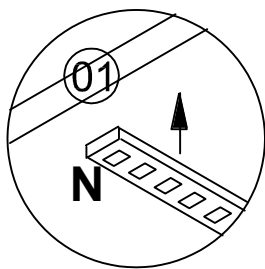
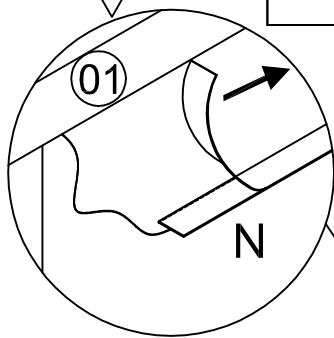

DE: Scannen Sie den QR-Code, um die  
 EN: Scan the QR code to download the app to control the LED light.  
 IT: Scansiona il codice QR per scaricare l'app per controllare la luce LED.  
 FR: Scannez le code QR pour télécharger l'application afin de contrôler la lumière LED.  
 ES: Escanea el código QR para descargar la aplicación y controlar la luz LED.

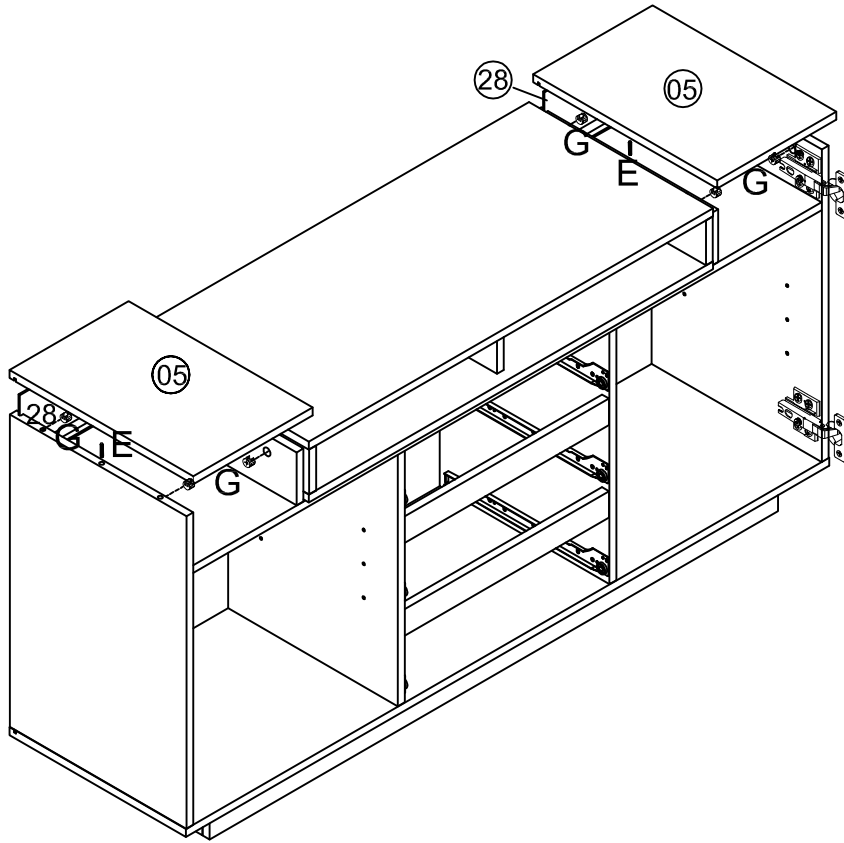
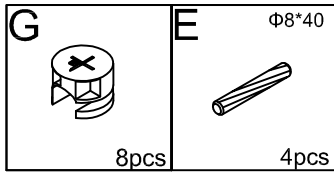

17

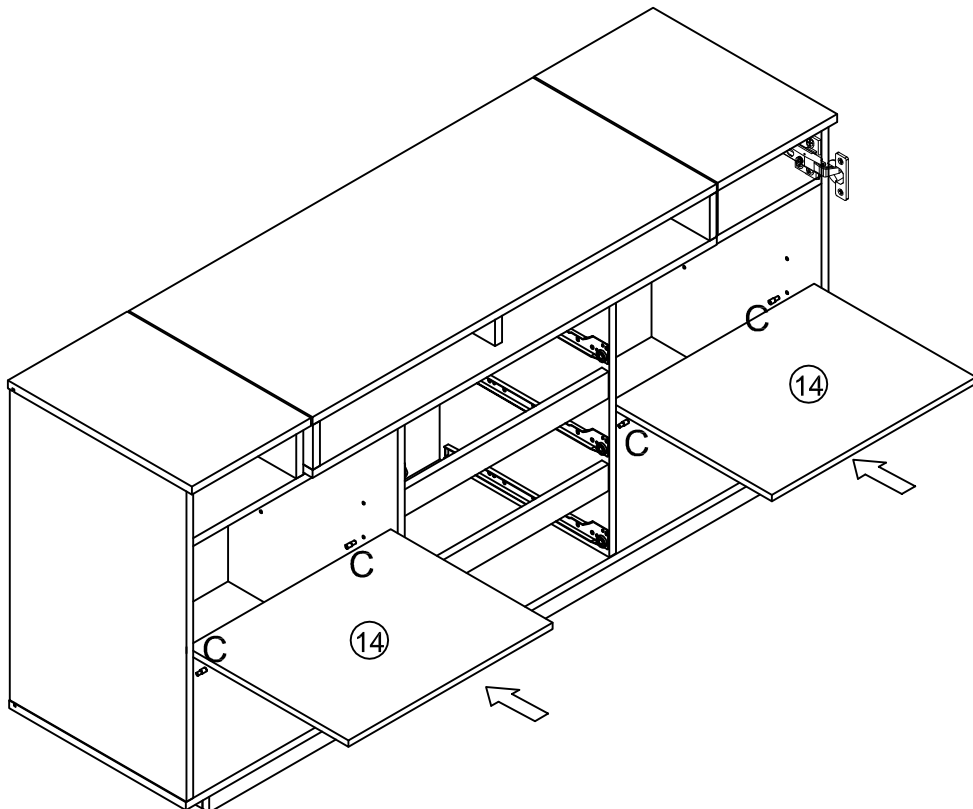
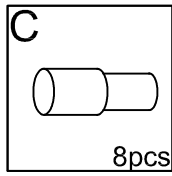

18



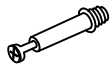

19

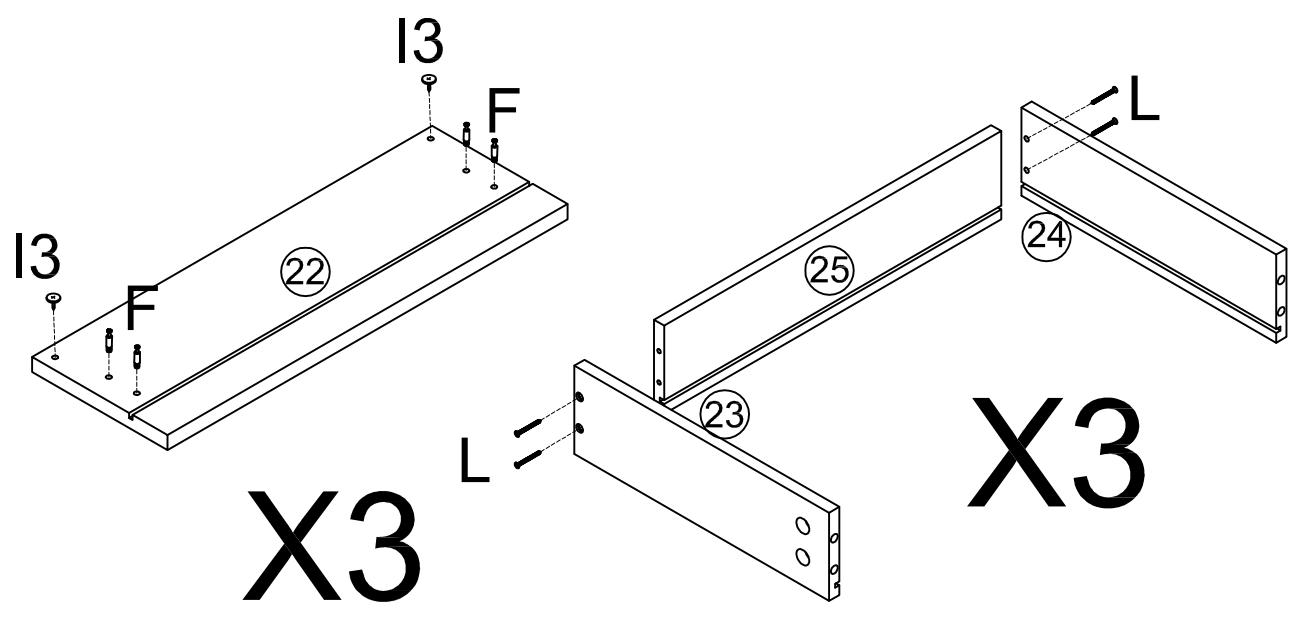
<b>F</b>  12pcs	<b>L</b> 3.5*35  12pcs	<b>I3</b>  6pcs
---	--	---



20

<b>G</b>  12pcs	<b>K</b> 3.5*14  12pcs	<b>D2</b>  3pcs
--	---	--

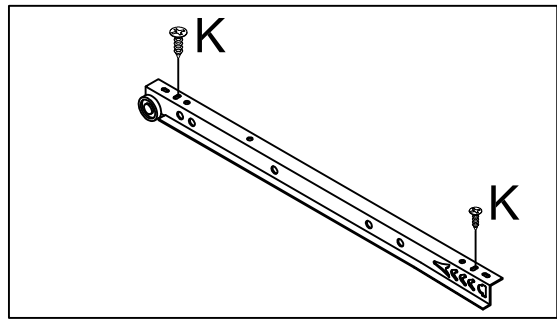
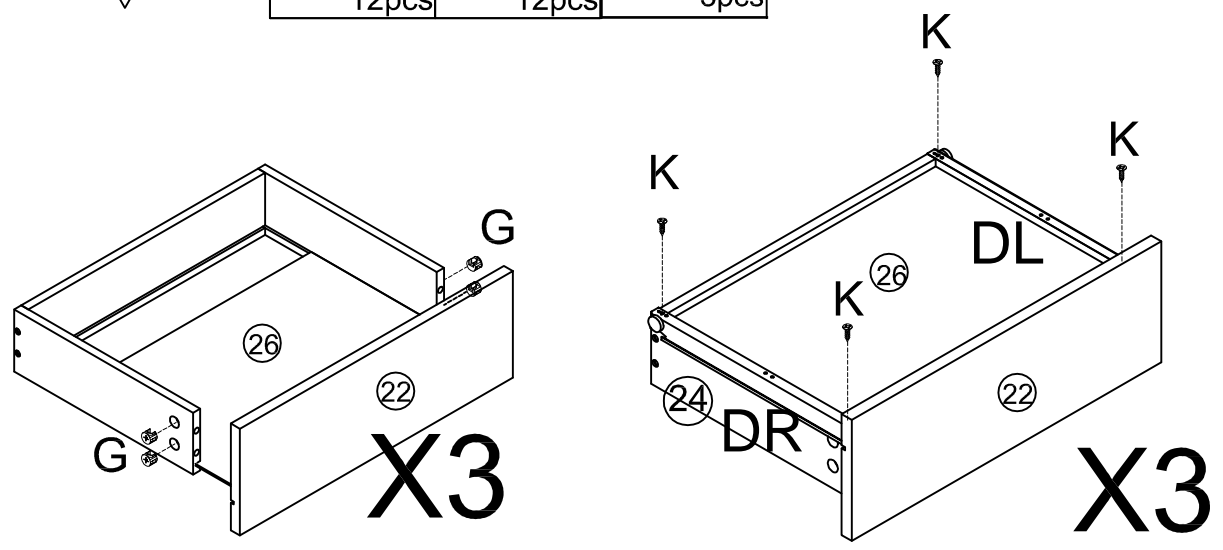

21

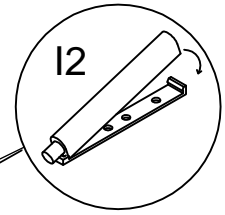
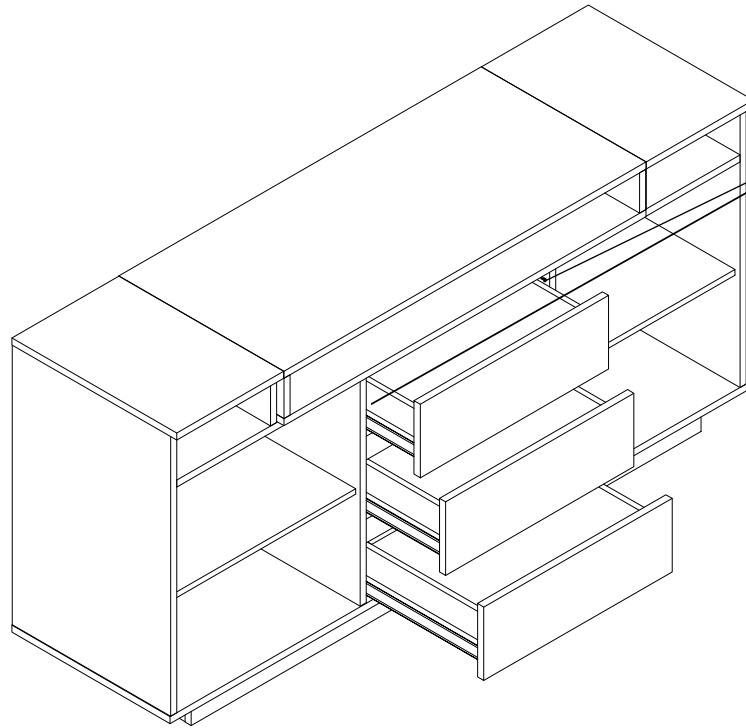
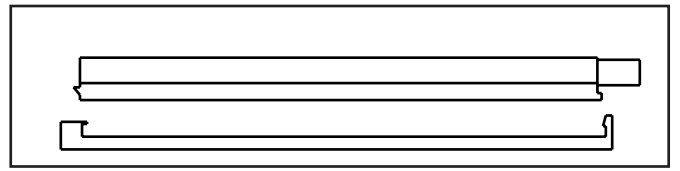
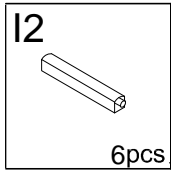

22

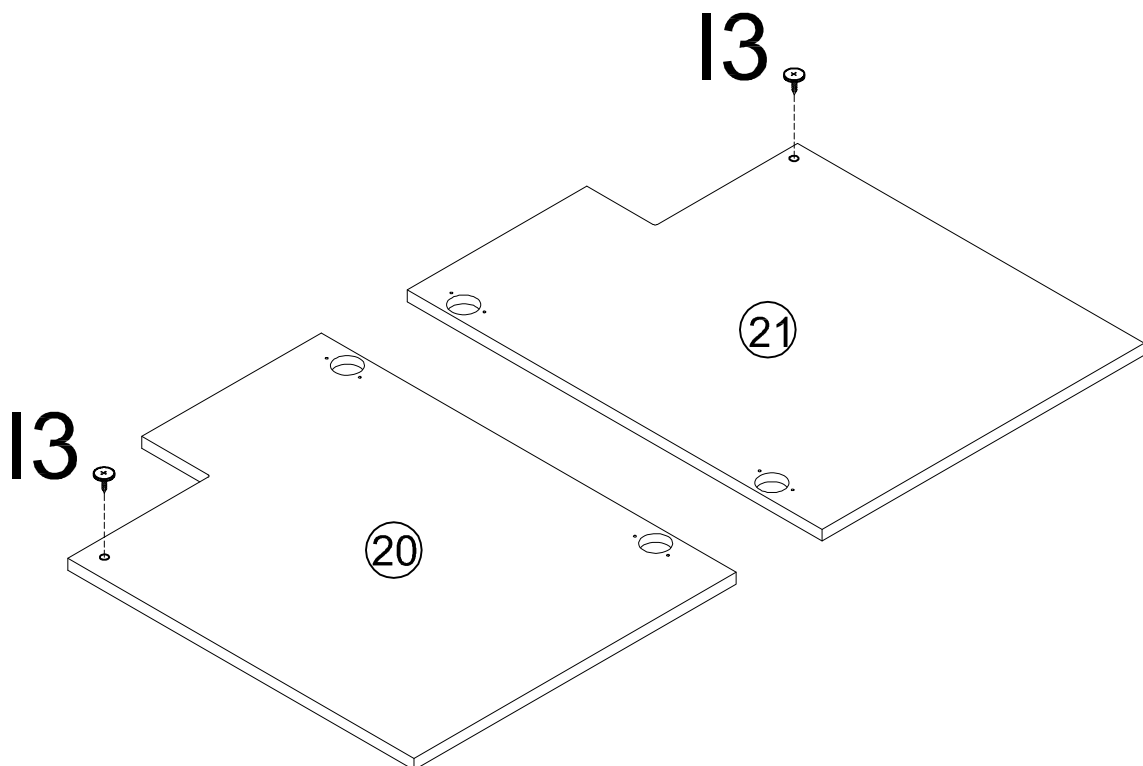
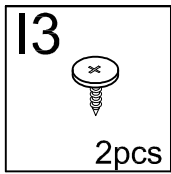

23

K 3.5\*14  
8pcs

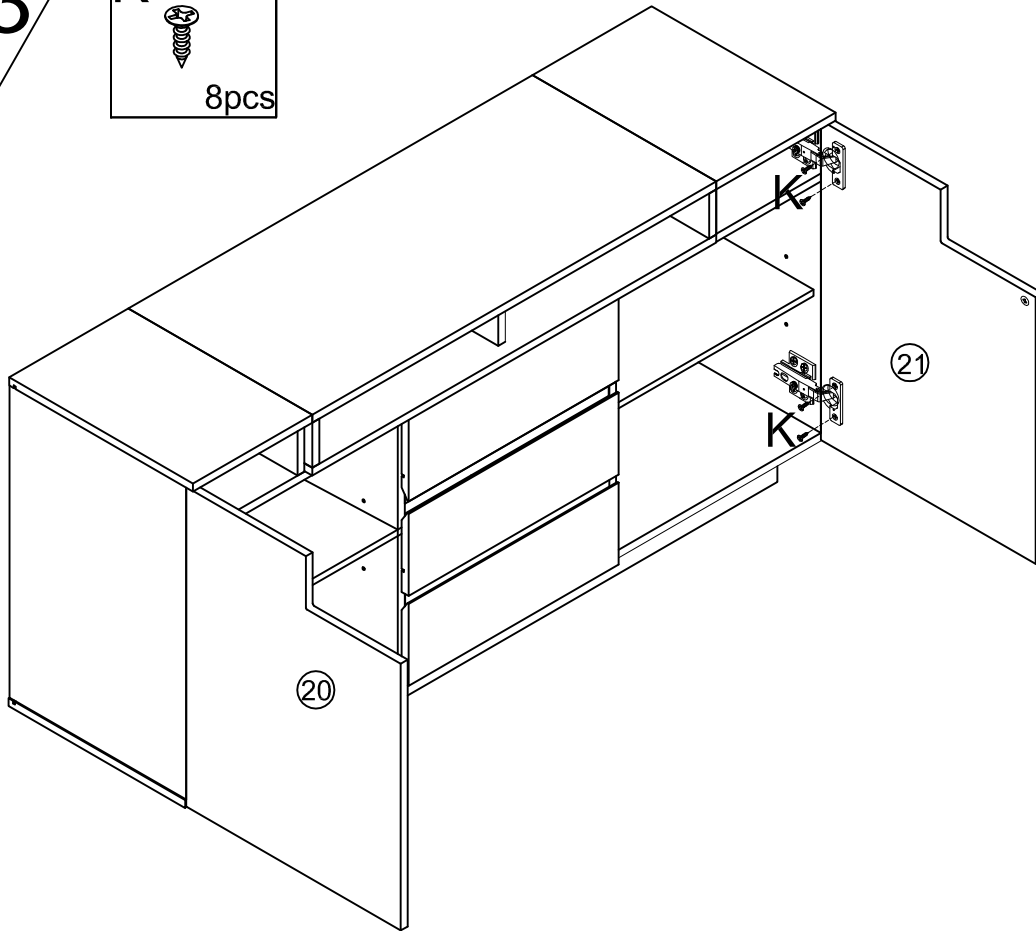

24

H K 3.5\*14  
12pcs 12pcs

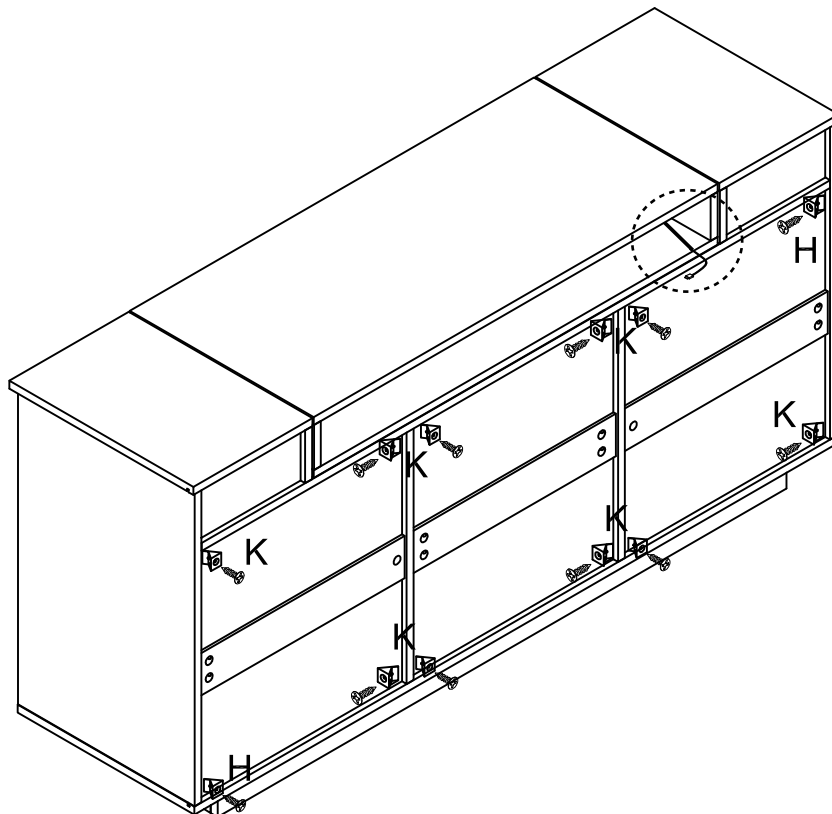

25

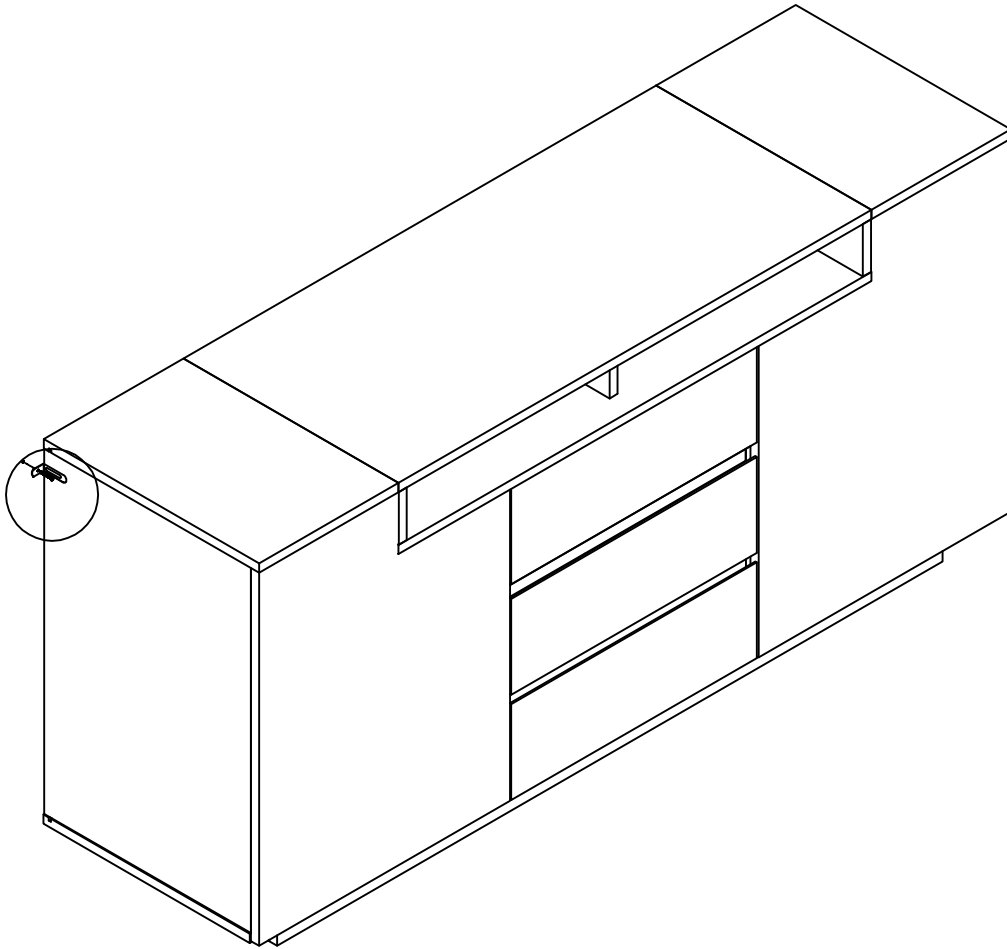
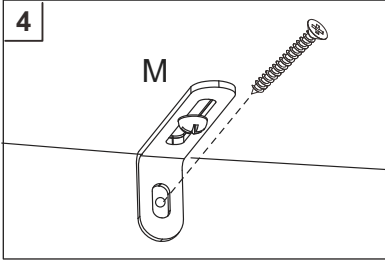
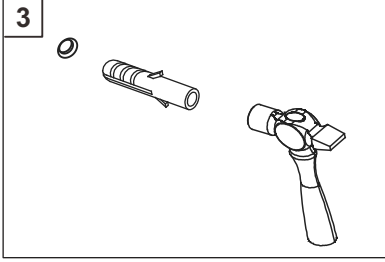
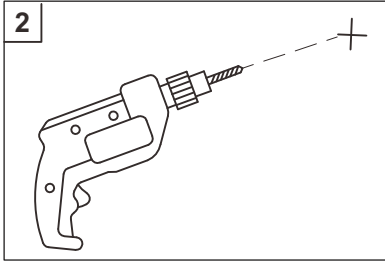
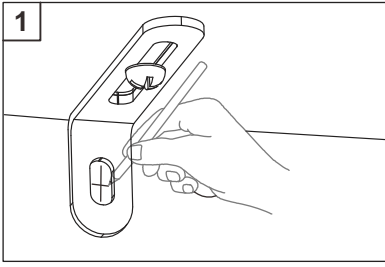
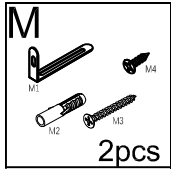

26

O x66

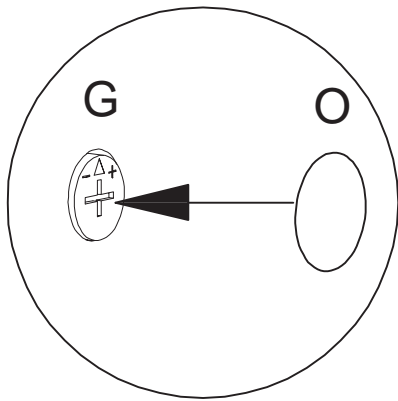
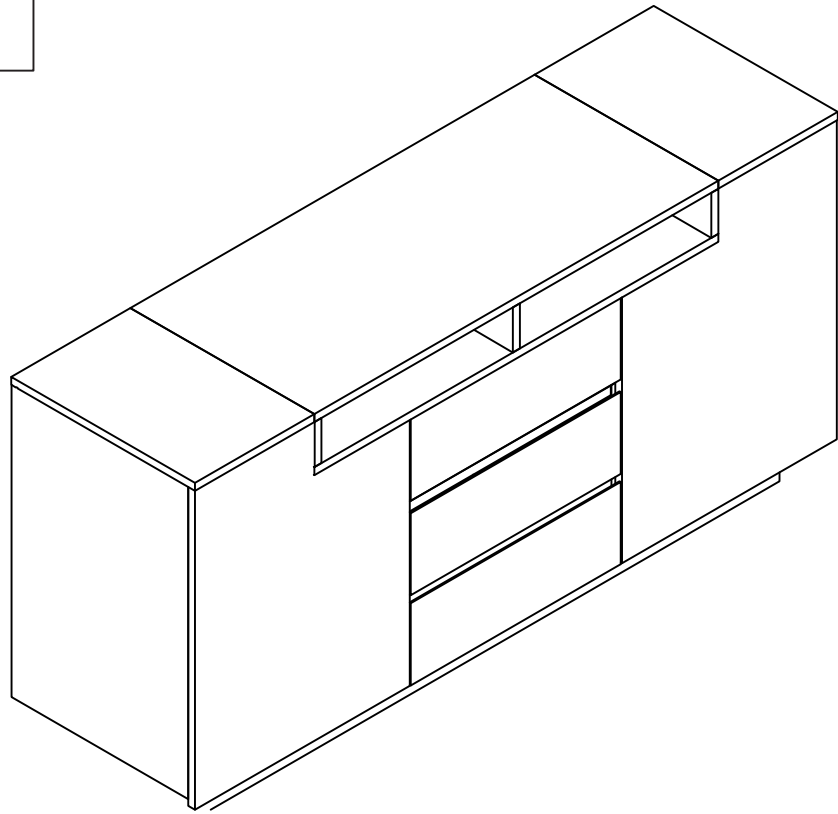
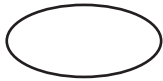

UK: After installing the product, stick the number O on the perforated position

FR: Une fois le produit installé, collez le numéro O à l'endroit où il y a des trous

DE: Nach der Installation des Produkts kleben Sie die Nummer O auf die perforierte Position

IT: Dopo l'installazione del prodotto, fissare il numero O sulla posizione perforata

ES: Después de instalar el producto, pegue el número O en la posición perforada

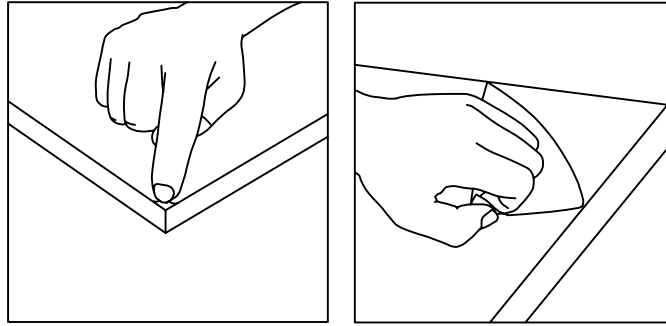

[DE]

**BITTE BEACHTEN:** Teilenummer 20.21.22 ist mit einer dichten Kunststoffschutzfolie überzogen. Wenn das Produkt nach der Demontage Kratzer aufweist, machen Sie sich bitte keine Sorgen, es handelt sich nicht um einen Produktschaden. Bitte ziehen Sie die schützende Kunststoffolie langsam entlang der Kante von der Oberfläche ab. Nach dem Abziehen wird das Produkt glatt und sauber.

[EN]

**PLEASE NOTE:** Part number 20.21.22 are covered with a tight plastic protective film. If there are scratches on the product after disassembly, please don't worry, it's not product damage. Please slowly tear off the protective plastic film on the surface along the edge. After peeling off, the product becomes smooth and clean.

[FR]

**REMARQUE :** les pièces numéro 20.21.22 sont recouvertes d'un film protecteur en plastique étanche. Si le produit présente des rayures après le démontage, ne vous inquiétez pas, il ne s'agit pas d'un dommage au produit. Retirez lentement le film protecteur en plastique sur la surface le long du bord. Une fois décollé, le produit devient lisse et propre.

[IT]

**NOTA BENE:** il numero di parte 20.21.22 è coperto da una pellicola protettiva in plastica stretta. Se ci sono graffi sul prodotto dopo lo smontaggio, non preoccuparti, non è un danno al prodotto. Strappare lentamente la pellicola protettiva in plastica sulla superficie lungo il bordo. Dopo averla staccata, il prodotto diventa liscio e pulito.

[ES]

**NOTA:** La pieza número 20.21.22 está cubierta con una película protectora de plástico. Si hay rayones en el producto después de desmontarlo, no se preocupe, no se trata de daños en el producto. Retire lentamente la película protectora de plástico de la superficie a lo largo del borde. Después de despegarla, el producto quedará liso y limpio.

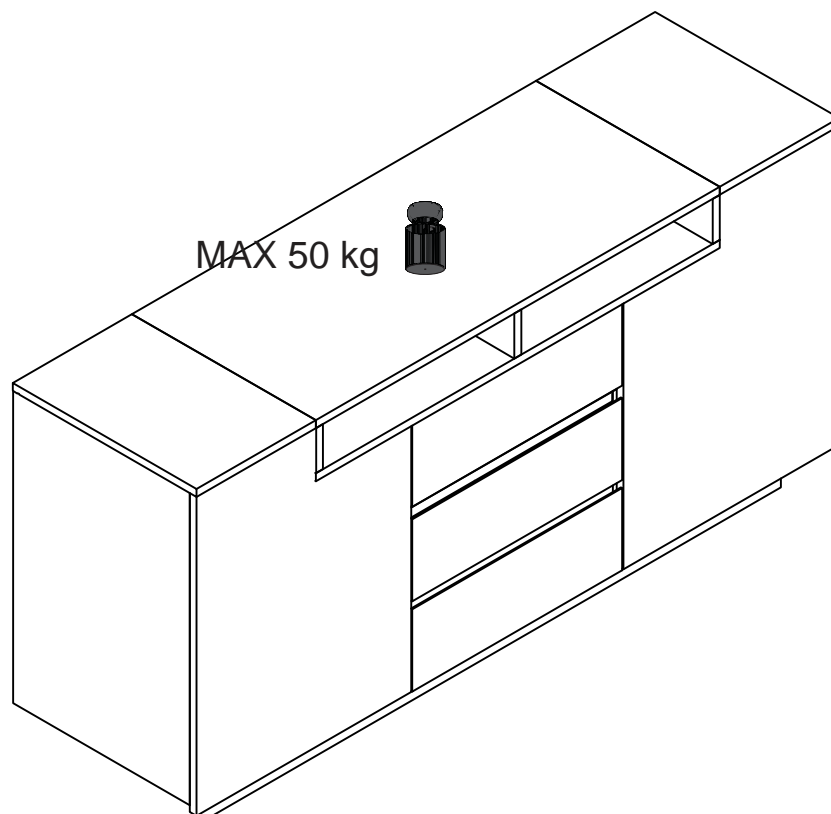

MAX 50 kg



# Certificate

Certificate Number: UNIA23010714EC-11



Product: LED low voltage light belt

Applicant: Shenzhen Light Belt Cloud Chain Lighting Co., Ltd  
303 Xingfu Building, Tongfu Industrial Zone, Aiqun Road, Shangwu Community, Shiyuan Street, Bao'an District, Shenzhen

Manufacturer: Shenzhen Light Belt Cloud Chain Lighting Co., Ltd  
303 Xingfu Building, Tongfu Industrial Zone, Aiqun Road, Shangwu Community, Shiyuan Street, Bao'an District, Shenzhen

Model No.: SMD 12V-2835-120, SMD 12V-2835-60, SMD 12V-2835-180, SMD 12V-2835-240

Trade Mark: N/A

Test Methods: EN IEC 55015:2019+A11:2020  
EN 61547:2009

The laboratory tested the product provided by the applicant according to the above test methods. According to the test results, the product conforms to EMC Directive (2014/30/EU) issued by the European Commission. It is possible to use CE marking to demonstrate the compliance with EMC Directive.

The certificate applies to the tested sample above mentioned only and shall not imply an assessment of the whole production. It is only valid in connection with the test report number: UNIA23010714ER-11.

Feb.09,2023  
Issue Date



Shenzhen United Testing Technology Co., Ltd.

Shenzhen:2/F.,Annex Building,Jiahuangyuan Tech Pack, No.355, Bao'an East Road,Tongang, Xixiang Street, Bao'an District, Shenzhen, Guangdong, China/518050  
Guangzhou:No.47-3, Industrial Road, Zhushan, Dalong Street, Panyu District, Guangzhou, Guangdong, China/511450  
Tel:+86-755-86180996/+86-020-39277769 Fax:+86- 0755-86180156  
Web.Site:www.uni-lab.hk/ E-mail:hofferlau@uni-lab.hk



Certificate of Compliance