

FLEXSTEEL®

W1042 - 91Q1 / 91Q2 / 90R3

Queen Panel Bed

IMPORTANT

Carefully remove all parts from the carton, and put them individually on a soft cloth to prevent damage to the parts.

We have taken great care in the design of this product and request that you carefully and accurately follow our assembly instructions to ensure proper set-up.

A Phillips Head Screwdriver is required for assembly (Not Provided)

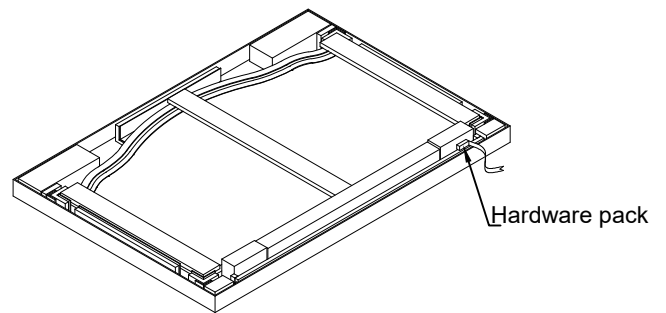
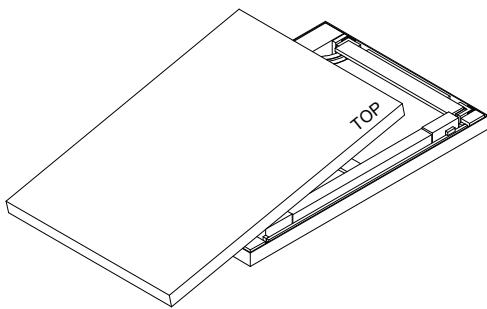
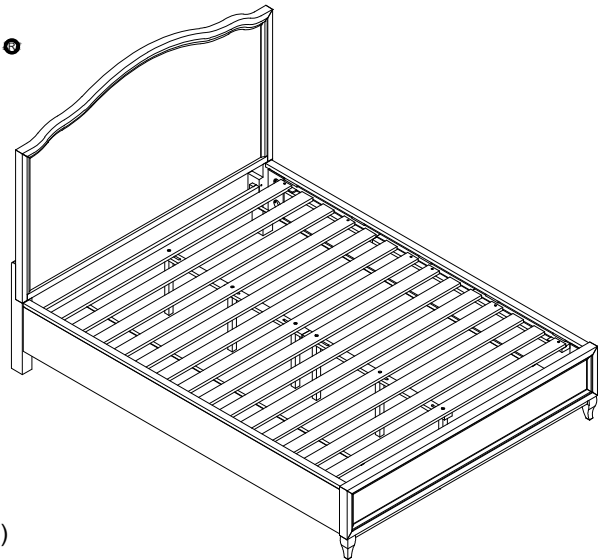

Part List

Assembly Instructions 1/4

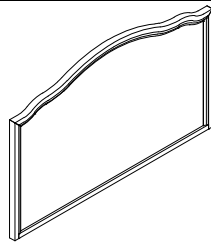

A. Headboard
1 piece

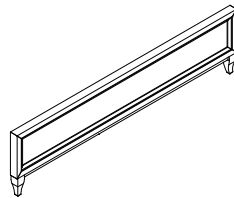

B. Footboard
1 piece

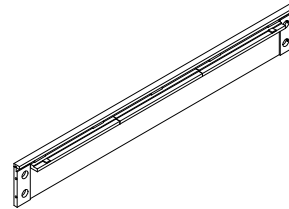

C. Side rail
2 pieces

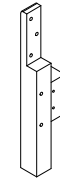

D. Headboard Post Left
1 piece

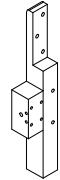

E. Headboard Post Right
1 piece

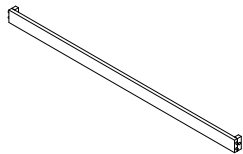

F. Headboard Bottom Rail
1 piece

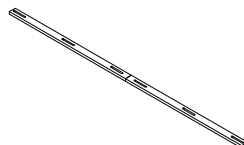

G. Center Rail
1 piece

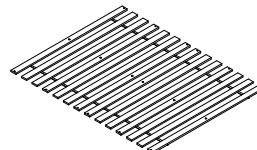

H. Roll Slats
1set



I. Slat Support
6 pieces

Hardware List

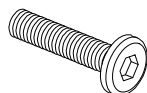

Bolt
Ø5/16" x 18 UNC x 1-1/2"
8 pieces



Spring Washer
Ø5/16" x 1.5mm
8 pieces



Flat Washer
Ø5/16" x Ø19 x 1.5mm
8 pieces

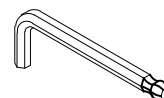

Hex Key
5/32"
1 piece

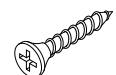

Screw
12 pieces

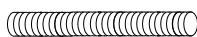

Thread Bolt
Ø5/16" x 18 UNC x 3-1/2"
8 pieces



Curved Washer
1" x 5/8" x 1/16"
8 pieces



Hexagonal Nut
Ø5/16" x 1/2"
8 pieces

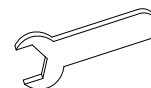

Spanner Wrench
1/2"
1 pieces

FLEXSTEEL®

Assembly Instructions 2/4

IMPORTANT NOTES

- Do not tighten up all the bolts until each part is properly assembled.
- Keep the Hex Key in a safe place as you may need to tighten up the bolts in the future.
- Use a soft cloth between these parts and the floor.
- We recommend this product be assembled by at least two adults.

STEP 1

Fix Headboard Post Left (D) and Headboard Post Right (E) to Headboard Bottom Rail (F). Insert Bolt, Spring Washer, Flat Washer and fully tighten bolts with Hex Key. (See Figure 1)

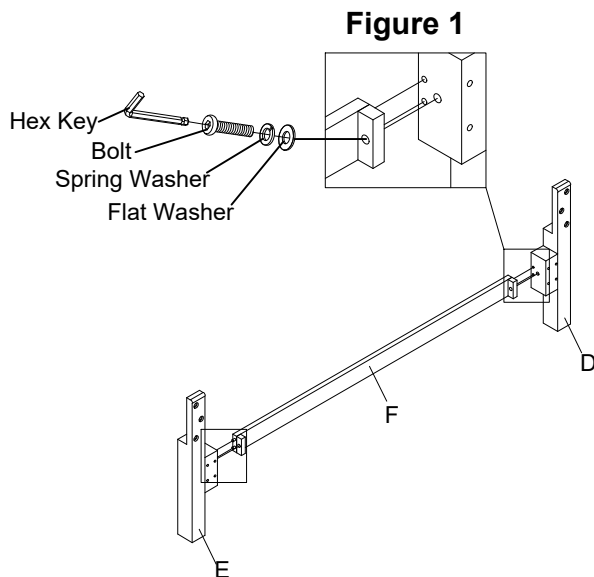

STEP 2

Fix Headboard Post Left (D) and Headboard Post Right (E) to Headboard (A). Insert Bolt, Spring Washer, Flat Washer and fully tighten bolts with Hex Key. (See Figure 2)

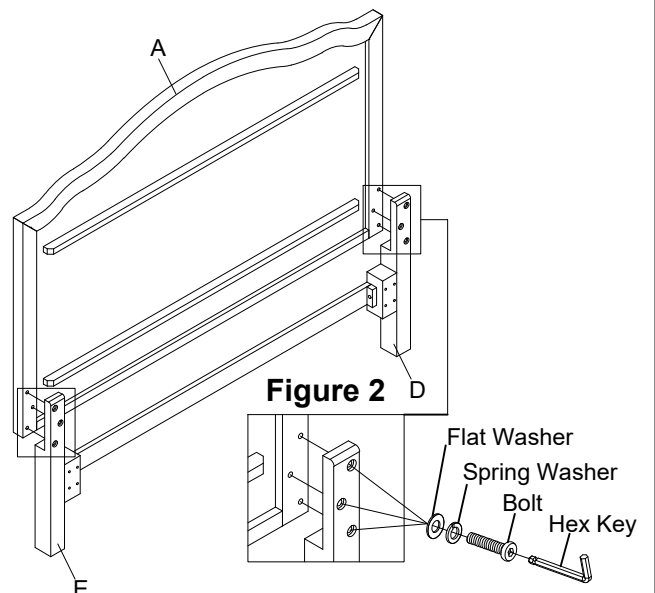

STEP 3

Connect the Side rail (C) to Headboard Post (D) and (E) and Footboard (B). Insert Thread Bolt, Curved Washer, Hexagonal Nut and fully tighten bolts with Spanner Wrench. (See Figure 3)

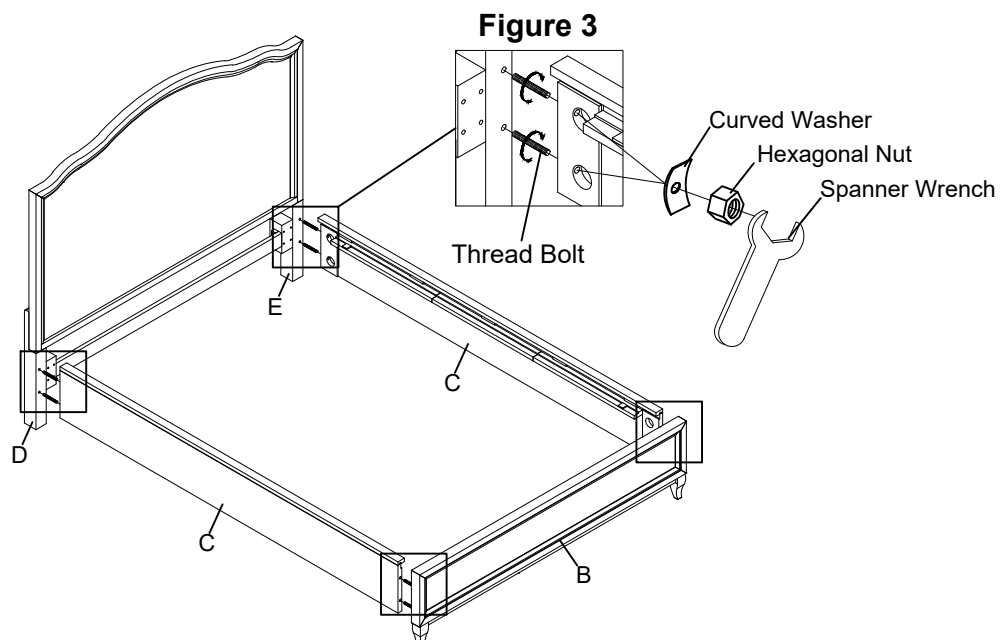

FLEXSTEEL®

Assembly Instructions 3/4

IMPORTANT NOTES

- Do not tighten up all the bolts until each part is properly assembled.
- Keep the Hex Key in a safe place as you may need to tighten up the bolts in the future.
- Use a soft cloth between these parts and the floor.
- We recommend this product be assembled by at least two adults.

STEP 4

Connect the Slat Support (I) and Center Rail (G) to Roll Slats (H). (See Figure 4)

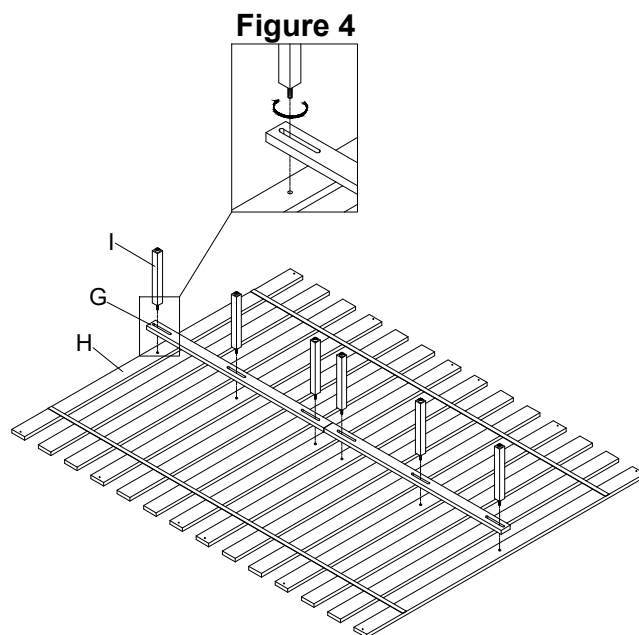

STEP 5

Fix Roll Slats (H) to Side rail (C). Insert Screw. (See Figure 5)

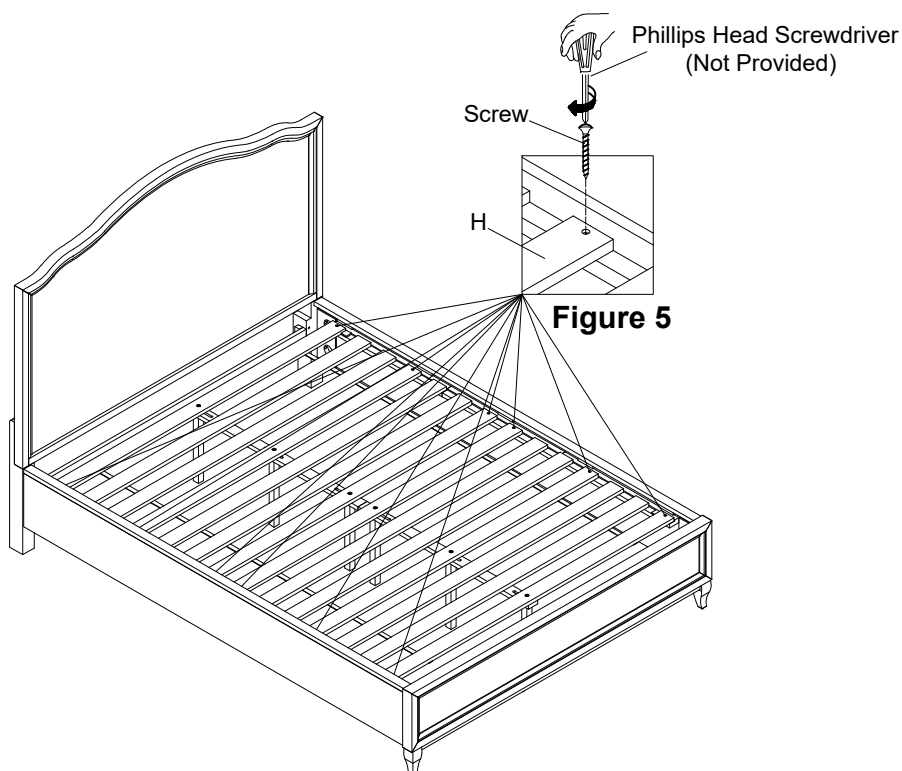

FLEXSTEEL®

Assembly Instructions 4/4

IMPORTANT NOTES

- Do not tighten up all the bolts until each part is properly assembled.
- Keep the Hex Key in a safe place as you may need to tighten up the bolts in the future.
- Use a soft cloth between these parts and the floor.
- We recommend this product be assembled by at least two adults.

STEP 6

Adjust the levelers on the Slat Supports (I) touching the floor. (See Figure 6)

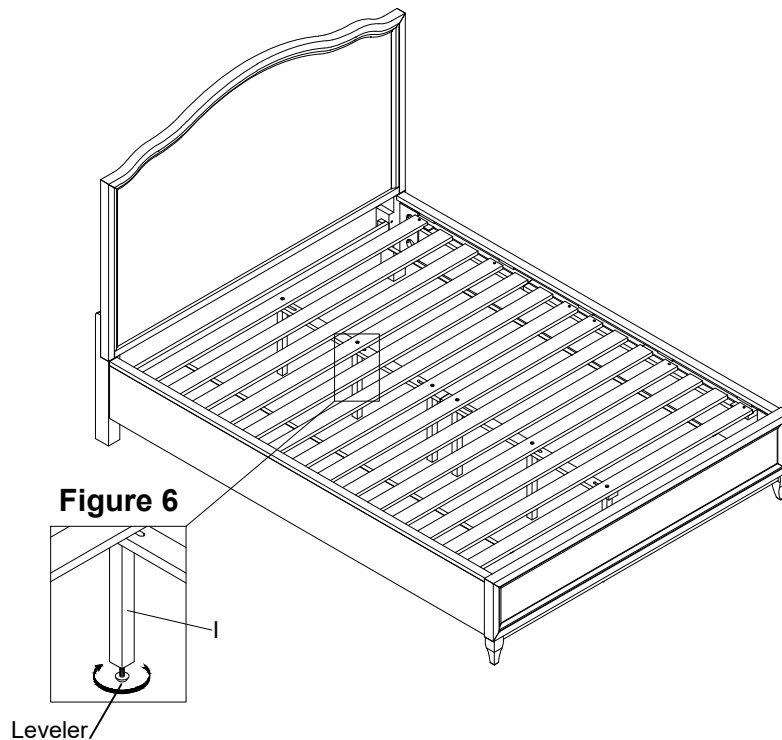

CARE INSTRUCTIONS

- To avoid scratches, do not place sharp or jagged objects directly on the bed.
- Do not place hot items directly on the bed.
- Avoid the use of harsh chemicals or abrasive cleaning materials.
- Wipe the bed clean with a soft, dry cloth after each use.
- Wipe up spills quickly with a soft, dry cloth.

Flexsteel Industries, Inc.

For Parts or Customer Service call

toll-free:

1-888-415-3979

Monday-Friday

8:00 a.m. -5:00 p.m.

(Central Time)

Email:

customersolutions@flexsteel.com

www.flexsteel.com

FLEXSTEEL®

W1042 - 91K1 / 91K2 / 90R3

King Panel Bed

IMPORTANT

Carefully remove all parts from the carton, and put them individually on a soft cloth to prevent damage to the parts.

We have taken great care in the design of this product and request that you carefully and accurately follow our assembly instructions to ensure proper set-up.

A Phillips Head Screwdriver is required for assembly (Not Provided)

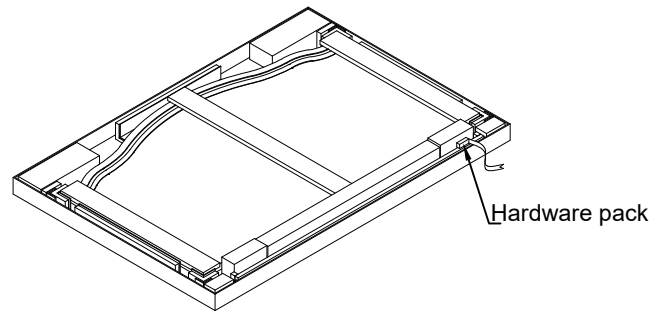
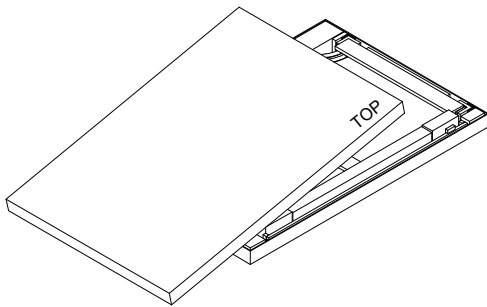
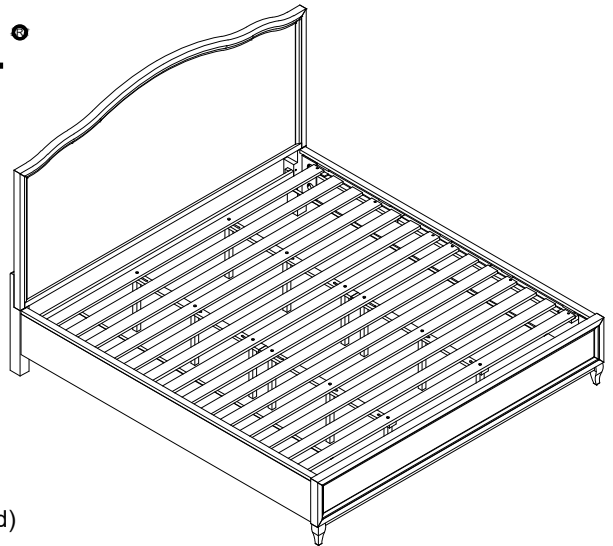

Part List

Assembly Instructions 1/4

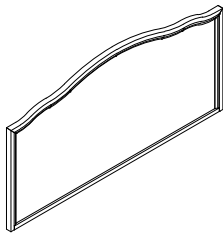

A. Headboard
1 piece

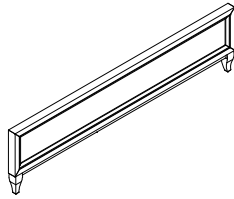

B. Footboard
1 piece

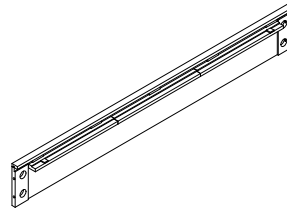

C. Side rail
2 pieces

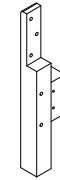

D. Headboard
Post Left
1 piece

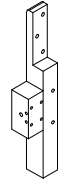

E. Headboard
Post Right
1 piece

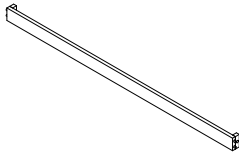

F. Headboard
Bottom Rail
1 piece

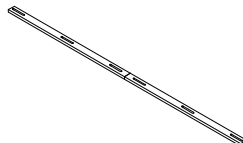

G. Center Rail
2 pieces

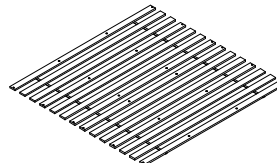

H. Roll Slats
1set



I. Slat Support
12 pieces

Hardware List

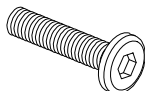

Bolt
Ø5/16" x 18 UNC x 1-1/2"
8 pieces



Spring Washer
Ø5/16" x 1.5mm
8 pieces



Flat Washer
Ø5/16" x Ø19 x 1.5mm
8 pieces

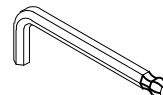

Hex Key
5/32"
1 piece

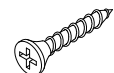

Screw
12 pieces

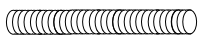

Thread Bolt
Ø5/16" x 18 UNC x 3-1/2"
8 pieces



Curved Washer
1" x 5/8" x 1/16"
8 pieces



Hexagonal Nut
Ø5/16" x 1/2"
8 pieces

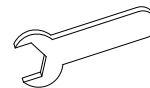

Spanner Wrench
1/2"
1 pieces

FLEXSTEEL®

Assembly Instructions 2/4

IMPORTANT NOTES

- Do not tighten up all the bolts until each part is properly assembled.
- Keep the Hex Key in a safe place as you may need to tighten up the bolts in the future.
- Use a soft cloth between these parts and the floor.
- We recommend this product be assembled by at least two adults.

STEP 1

Fix Headboard Post Left (D) and Headboard Post Right (E) to Headboard Bottom Rail (F). Insert Bolt, Spring Washer, Flat Washer and fully tighten bolts with Hex Key. (See Figure 1)

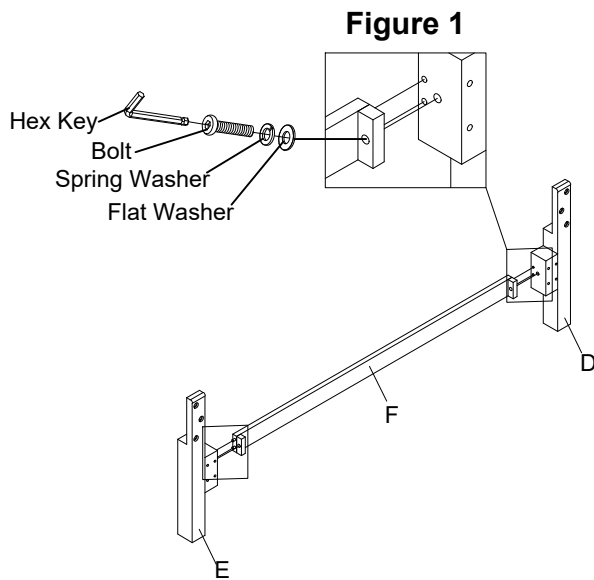

STEP 2

Fix Headboard Post Left (D) and Headboard Post Right (E) to Headboard (A). Insert Bolt, Spring Washer, Flat Washer and fully tighten bolts with Hex Key. (See Figure 2)

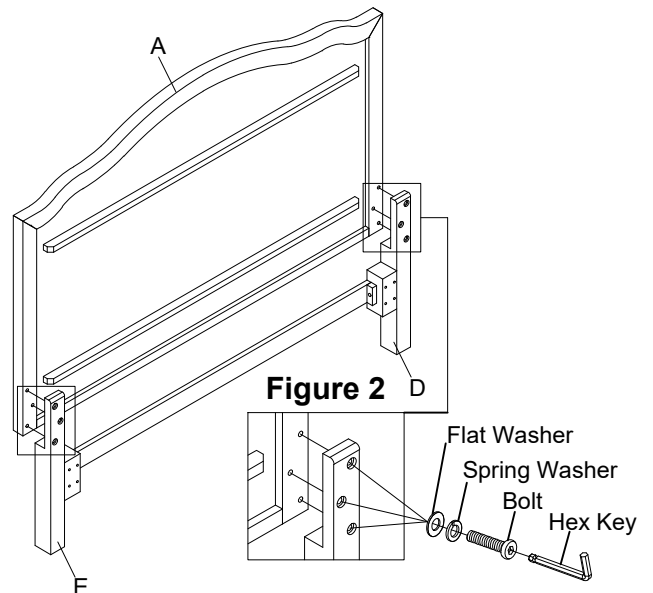

STEP 3

Connect the Side rail (C) to Headboard Post (D) and (E) and Footboard (B). Insert Thread Bolt, Curved Washer, Hexagonal Nut and fully tighten bolts with Spanner Wrench. (See Figure 3)

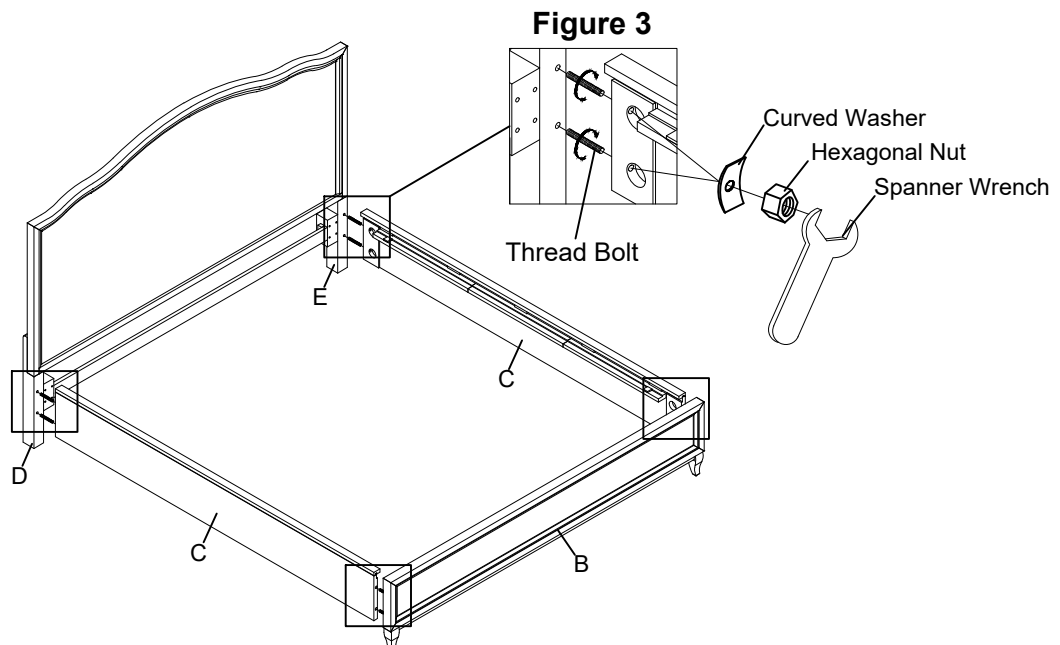

FLEXSTEEL®

Assembly Instructions 3/4

IMPORTANT NOTES

- Do not tighten up all the bolts until each part is properly assembled.
- Keep the Hex Key in a safe place as you may need to tighten up the bolts in the future.
- Use a soft cloth between these parts and the floor.
- We recommend this product be assembled by at least two adults.

STEP 4

Connect the Slat Support (I) and Center Rail (G) to Roll Slats (H). (See Figure 4)

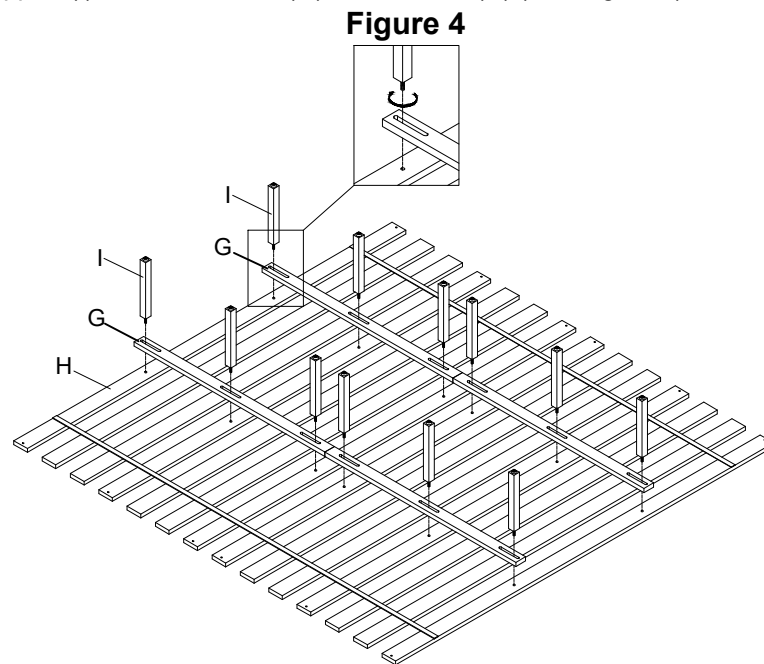

STEP 5

Fix Roll Slats (H) to Side rail (C). Insert Screw. (See Figure 5)

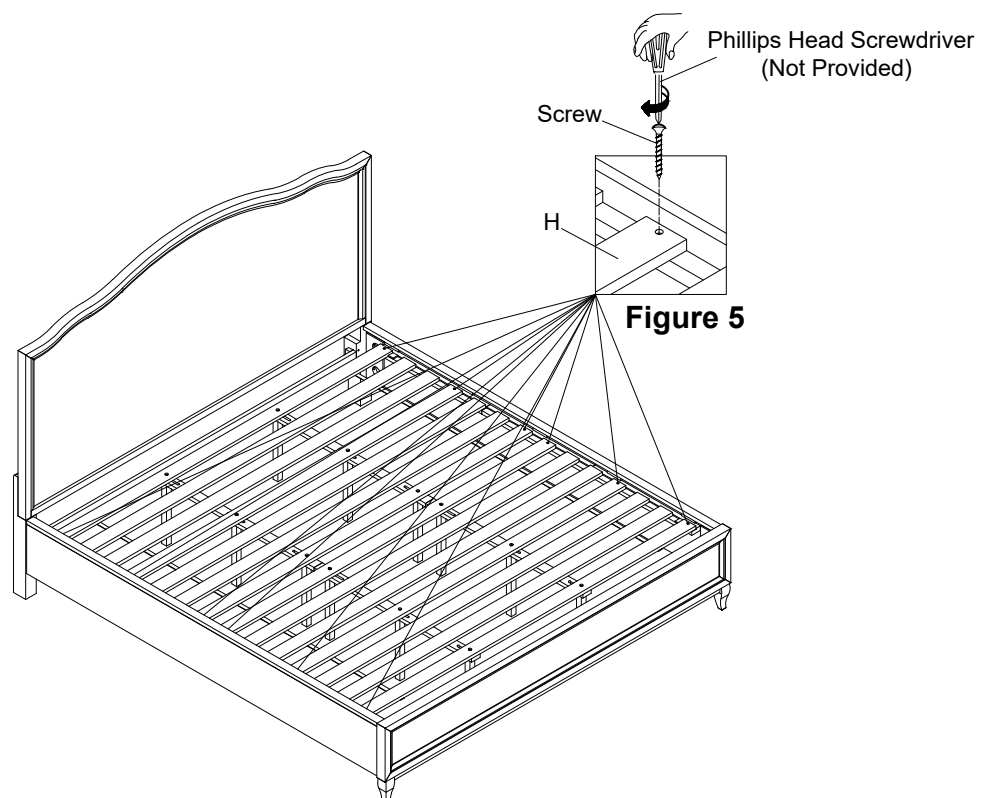

FLEXSTEEL®

Assembly Instructions 4/4

IMPORTANT NOTES

- Do not tighten up all the bolts until each part is properly assembled.
- Keep the Hex Key in a safe place as you may need to tighten up the bolts in the future.
- Use a soft cloth between these parts and the floor.
- We recommend this product be assembled by at least two adults.

STEP 6

Adjust the levelers on the Slat Supports (I) touching the floor. (See Figure 6)

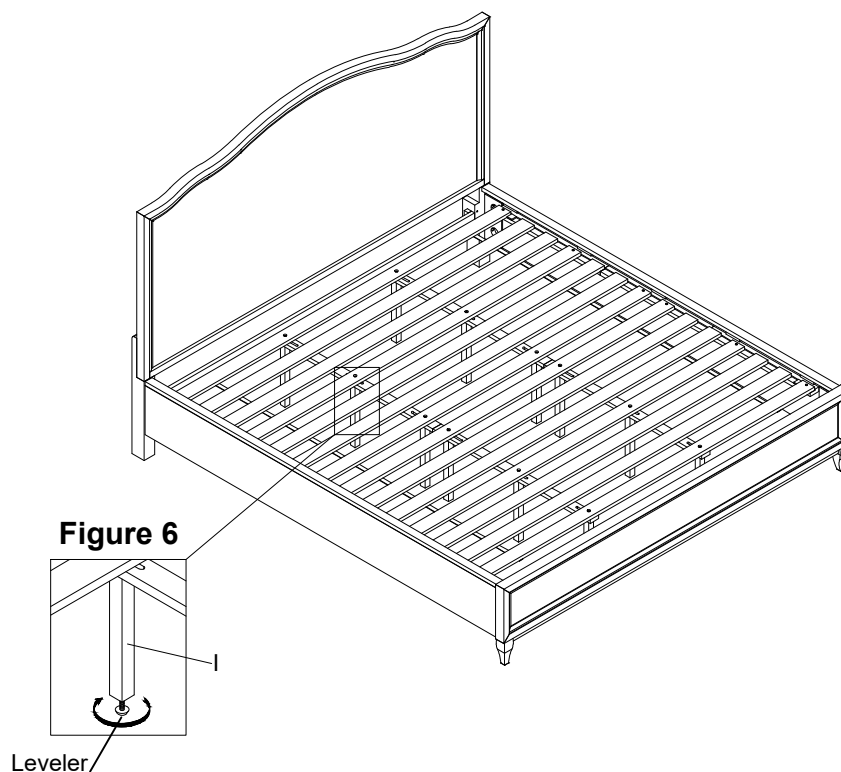

CARE INSTRUCTIONS

- To avoid scratches, do not place sharp or jagged objects directly on the bed.
- Do not place hot items directly on the bed.
- Avoid the use of harsh chemicals or abrasive cleaning materials.
- Wipe the bed clean with a soft, dry cloth after each use.
- Wipe up spills quickly with a soft, dry cloth.

Flexsteel Industries, Inc.

For Parts or Customer Service call

toll-free:

1-888-415-3979

Monday-Friday

8:00 a.m. -5:00 p.m.

(Central Time)

Email:

customersolutions@flexsteel.com

www.flexsteel.com

FLEXSTEEL®

W1042 - 90Q1 / 90Q2 / 90R3

Queen UPH Bed

IMPORTANT

Carefully remove all parts from the carton, and put them individually on a soft cloth to prevent damage to the parts.

We have taken great care in the design of this product and request that you carefully and accurately follow our assembly instructions to ensure proper set-up.

A Phillips Head Screwdriver is required for assembly (Not Provided)

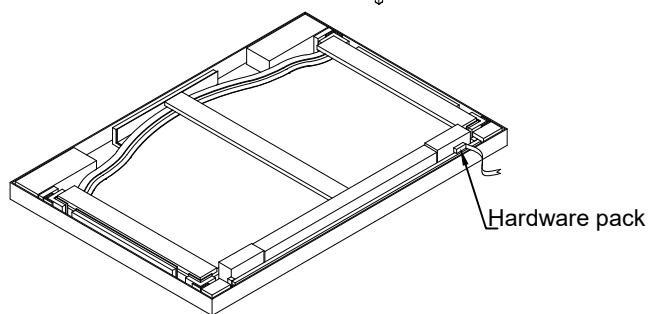
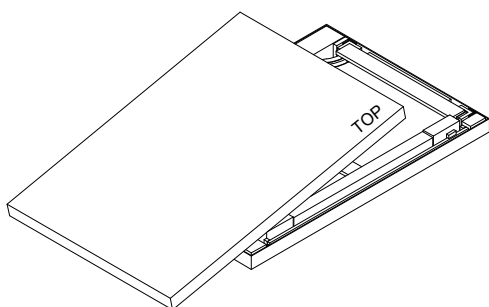
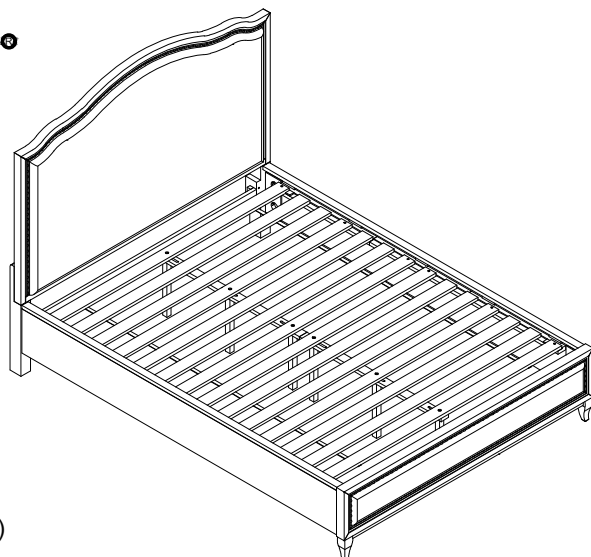

Part List

Assembly Instructions 1/4

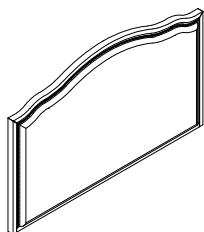

A. Headboard
1 piece

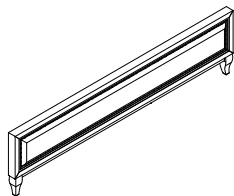

B. Footboard
1 piece

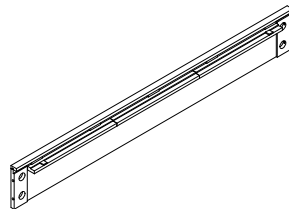

C. Side rail
2 pieces

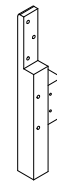

D. Headboard Post Left
1 piece



E. Headboard Post Right
1 piece

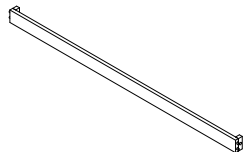

F. Headboard Bottom Rail
1 piece

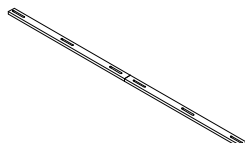

G. Center Rail
1 piece

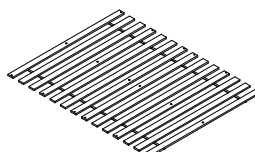

H. Roll Slats
1set



I. Slat Support
6 pieces

Hardware List

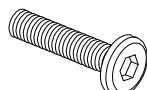

Bolt
Ø5/16" x 18 UNC x 1-1/2"
8 pieces



Spring Washer
Ø5/16" x 1.5mm
8 pieces



Flat Washer
Ø5/16" x Ø19 x 1.5mm
8 pieces

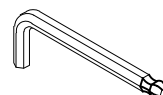

Hex Key
5/32"
1 piece

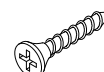

Screw
12 pieces

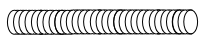

Thread Bolt
Ø5/16" x 18 UNC x 3-1/2"
8 pieces



Curved Washer
1" x 5/8" x 1/16"
8 pieces



Hexagonal Nut
Ø5/16" x 1/2"
8 pieces



Spanner Wrench
1/2"
1 pieces

FLEXSTEEL®

Assembly Instructions 2/4

IMPORTANT NOTES

- Do not tighten up all the bolts until each part is properly assembled.
- Keep the Hex Key in a safe place as you may need to tighten up the bolts in the future.
- Use a soft cloth between these parts and the floor.
- We recommend this product be assembled by at least two adults.

STEP 1

Fix Headboard Post Left (D) and Headboard Post Right (E) to Headboard Bottom Rail (F). Insert Bolt, Spring Washer, Flat Washer and fully tighten bolts with Hex Key. (See Figure 1)

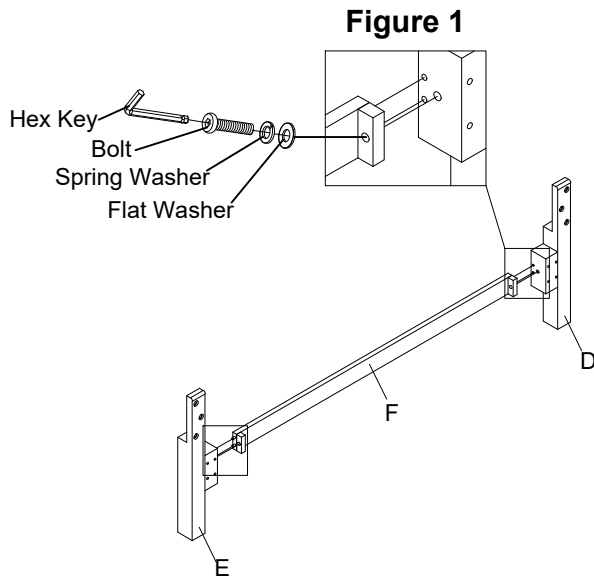

STEP 2

Fix Headboard Post Left (D) and Headboard Post Right (E) to Headboard (A). Insert Bolt, Spring Washer, Flat Washer and fully tighten bolts with Hex Key. (See Figure 2)

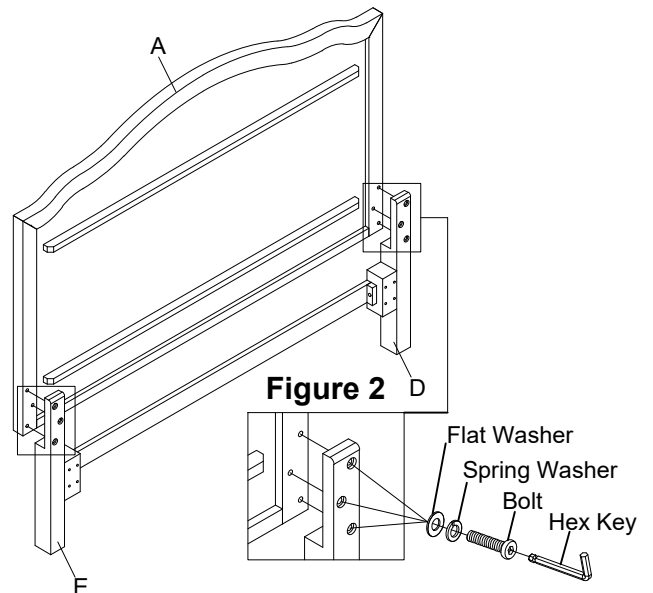

STEP 3

Connect the Side rail (C) to Headboard Post (D) and (E) and Footboard (B). Insert Thread Bolt, Curved Washer, Hexagonal Nut and fully tighten bolts with Spanner Wrench. (See Figure 3)

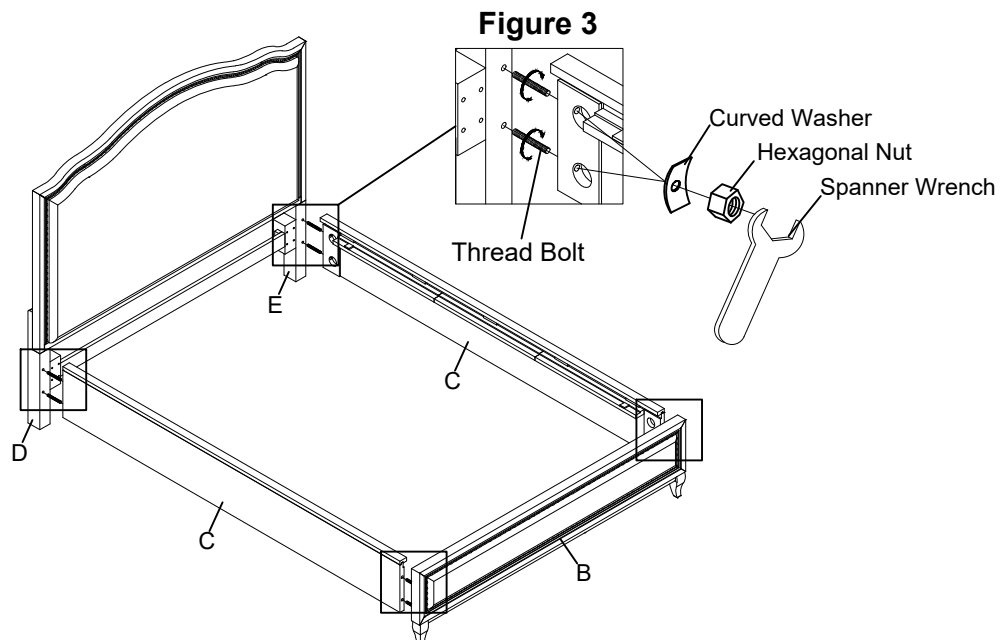

FLEXSTEEL®

Assembly Instructions 3/4

IMPORTANT NOTES

- Do not tighten up all the bolts until each part is properly assembled.
- Keep the Hex Key in a safe place as you may need to tighten up the bolts in the future.
- Use a soft cloth between these parts and the floor.
- We recommend this product be assembled by at least two adults.

STEP 4

Connect the Slat Support (I) and Center Rail (G) to Roll Slats (H). (See Figure 4)

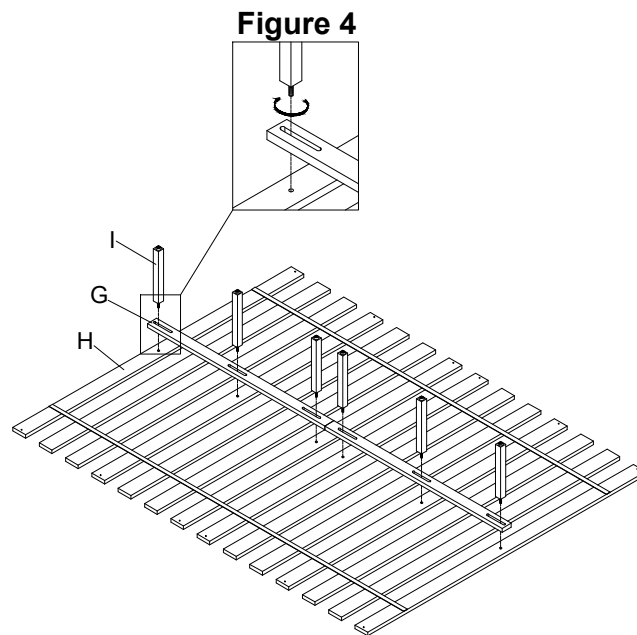

STEP 5

Fix Roll Slats (H) to Side rail (C). Insert Screw. (See Figure 5)

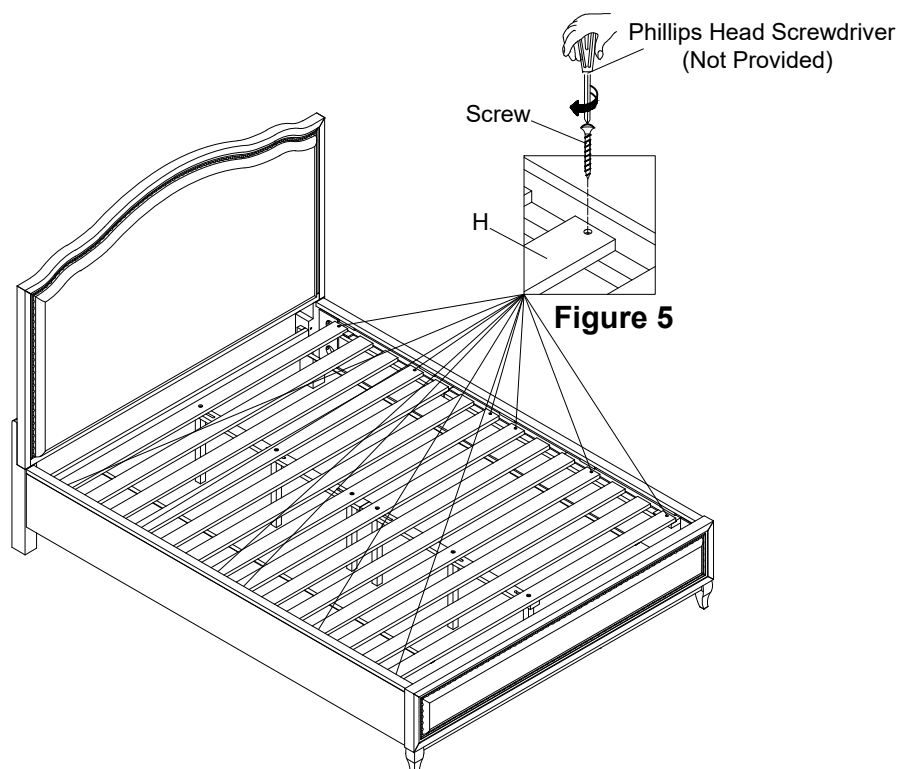

FLEXSTEEL®

Assembly Instructions 4/4

IMPORTANT NOTES

- Do not tighten up all the bolts until each part is properly assembled.
- Keep the Hex Key in a safe place as you may need to tighten up the bolts in the future.
- Use a soft cloth between these parts and the floor.
- We recommend this product be assembled by at least two adults.

STEP 6

Adjust the levelers on the Slat Supports (I) touching the floor. (See Figure 6)

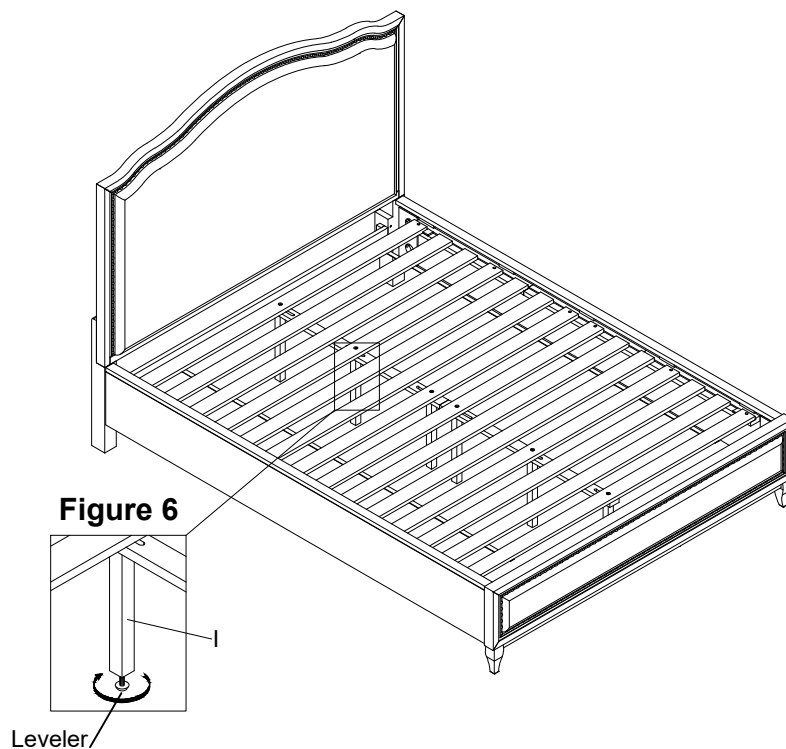

CARE INSTRUCTIONS

- To avoid scratches, do not place sharp or jagged objects directly on the bed.
- Do not place hot items directly on the bed.
- Avoid the use of harsh chemicals or abrasive cleaning materials.
- Wipe the bed clean with a soft, dry cloth after each use.
- Wipe up spills quickly with a soft, dry cloth.

Flexsteel Industries, Inc.

For Parts or Customer Service call

toll-free:

1-888-415-3979

Monday-Friday

8:00 a.m. -5:00 p.m.

(Central Time)

Email:

customersolutions@flexsteel.com

www.flexsteel.com

FLEXSTEEL®

W1042 - 90K1 / 90K2 / 90R3

King UPH Bed

IMPORTANT

Carefully remove all parts from the carton, and put them individually on a soft cloth to prevent damage to the parts.

We have taken great care in the design of this product and request that you carefully and accurately follow our assembly instructions to ensure proper set-up.

A Phillips Head Screwdriver is required for assembly (Not Provided)

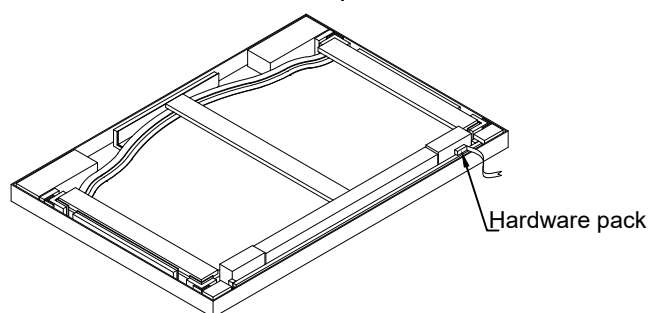
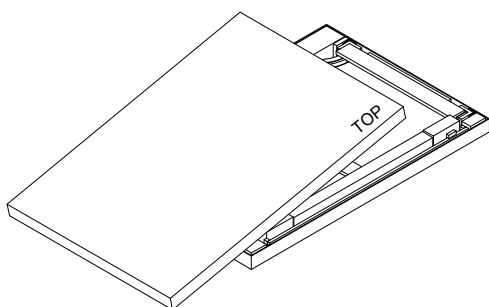
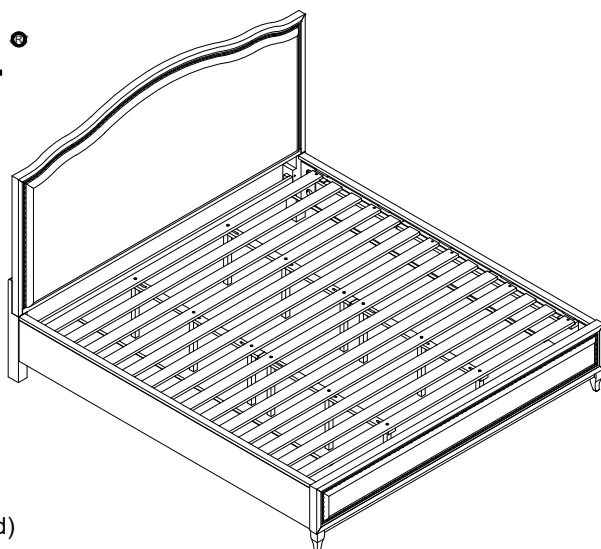

Part List

Assembly Instructions 1/4

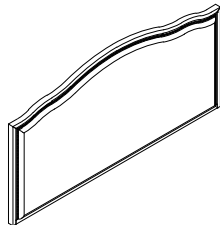

A. Headboard
1 piece

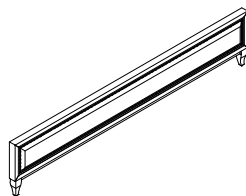

B. Footboard
1 piece

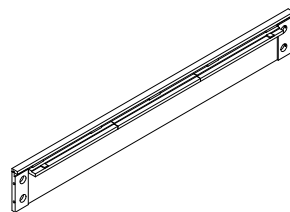

C. Side rail
2 pieces

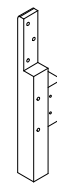

D. Headboard
Post Left
1 piece



E. Headboard
Post Right
1 piece

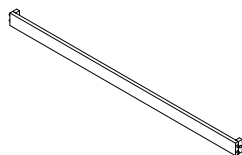

F. Headboard
Bottom Rail
1 piece

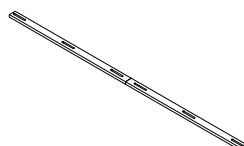

G. Center Rail
2 pieces

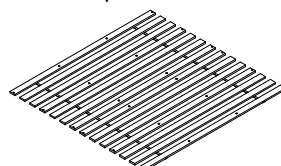

H. Roll Slats
1set



I. Slat Support
12 pieces

Hardware List

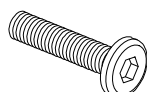

Bolt
Ø5/16" x 18 UNC x 1-1/2"
8 pieces



Spring Washer
Ø5/16" x 1.5mm
8 pieces



Flat Washer
Ø5/16" x Ø19 x 1.5mm
8 pieces

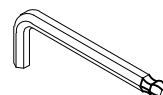

Hex Key
5/32"
1 piece



Screw
12 pieces

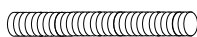

Thread Bolt
Ø5/16" x 18 UNC x 3-1/2"
8 pieces



Curved Washer
1" x 5/8" x 1/16"
8 pieces



Hexagonal Nut
Ø5/16" x 1/2"
8 pieces

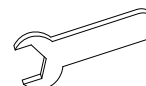

Spanner Wrench
1/2"
1 pieces

FLEXSTEEL®

Assembly Instructions 2/4

IMPORTANT NOTES

- Do not tighten up all the bolts until each part is properly assembled.
- Keep the Hex Key in a safe place as you may need to tighten up the bolts in the future.
- Use a soft cloth between these parts and the floor.
- We recommend this product be assembled by at least two adults.

STEP 1

Fix Headboard Post Left (D) and Headboard Post Right (E) to Headboard Bottom Rail (F). Insert Bolt, Spring Washer, Flat Washer and fully tighten bolts with Hex Key. (See Figure 1)

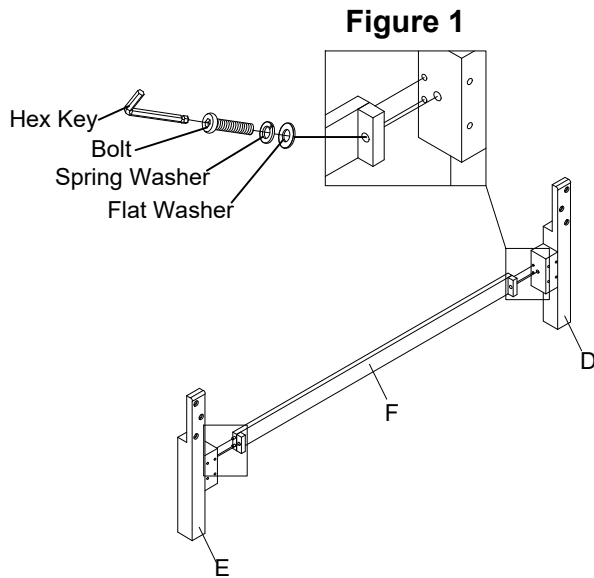

STEP 2

Fix Headboard Post Left (D) and Headboard Post Right (E) to Headboard (A). Insert Bolt, Spring Washer, Flat Washer and fully tighten bolts with Hex Key. (See Figure 2)

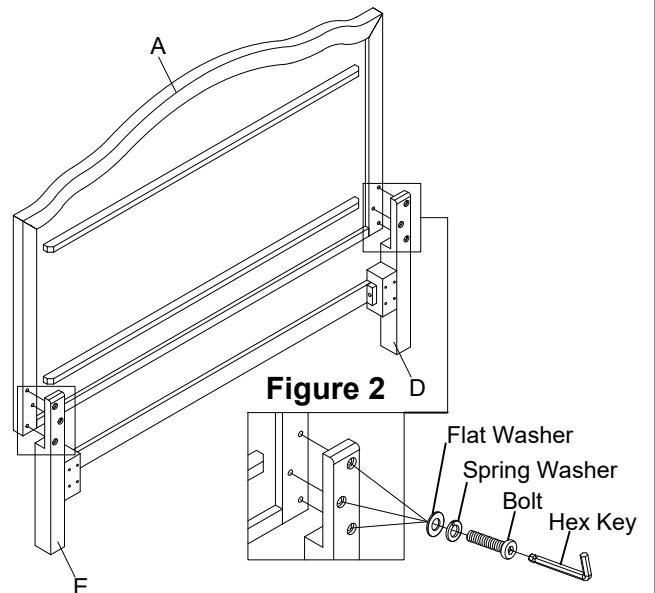

STEP 3

Connect the Side rail (C) to Headboard Post (D) and (E) and Footboard (B). Insert Thread Bolt, Curved Washer, Hexagonal Nut and fully tighten bolts with Spanner Wrench. (See Figure 3)

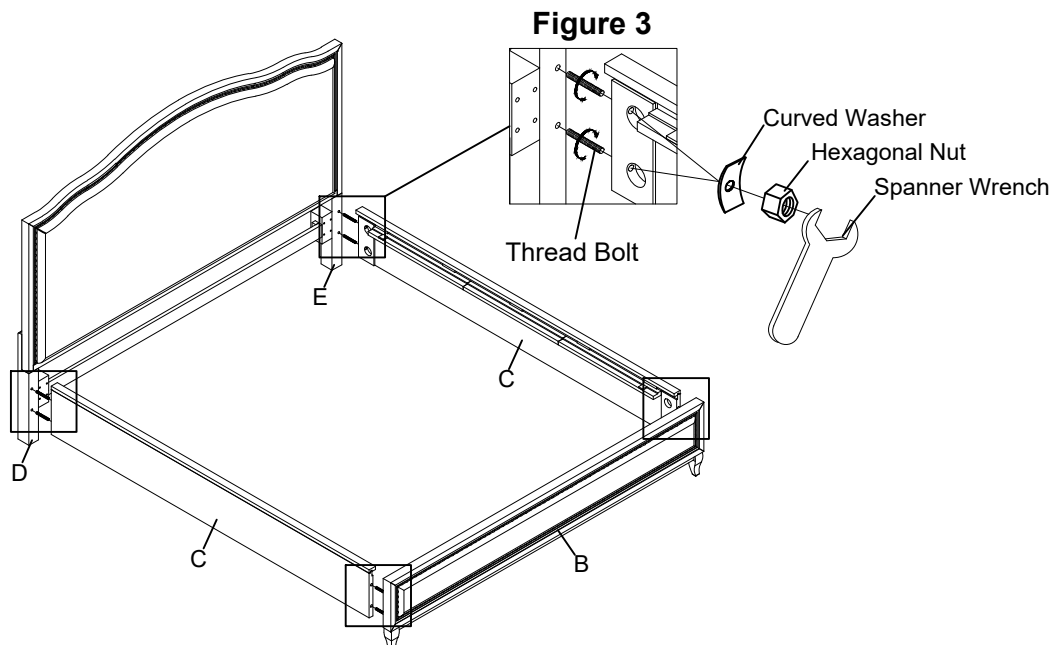

FLEXSTEEL®

Assembly Instructions 3/4

IMPORTANT NOTES

- Do not tighten up all the bolts until each part is properly assembled.
- Keep the Hex Key in a safe place as you may need to tighten up the bolts in the future.
- Use a soft cloth between these parts and the floor.
- We recommend this product be assembled by at least two adults.

STEP 4

Connect the Slat Support (I) and Center Rail (G) to Roll Slats (H). (See Figure 4)

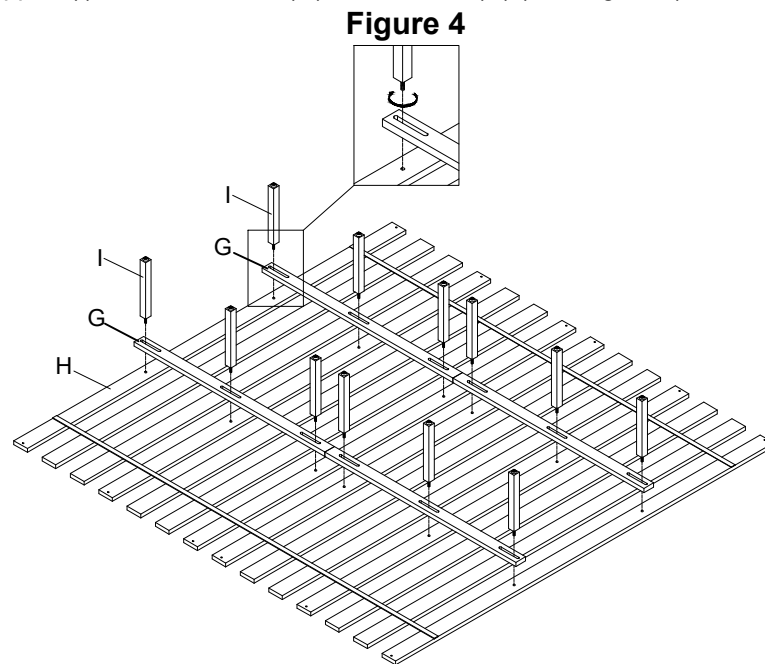

STEP 5

Fix Roll Slats (H) to Side rail (C). Insert Screw. (See Figure 5)

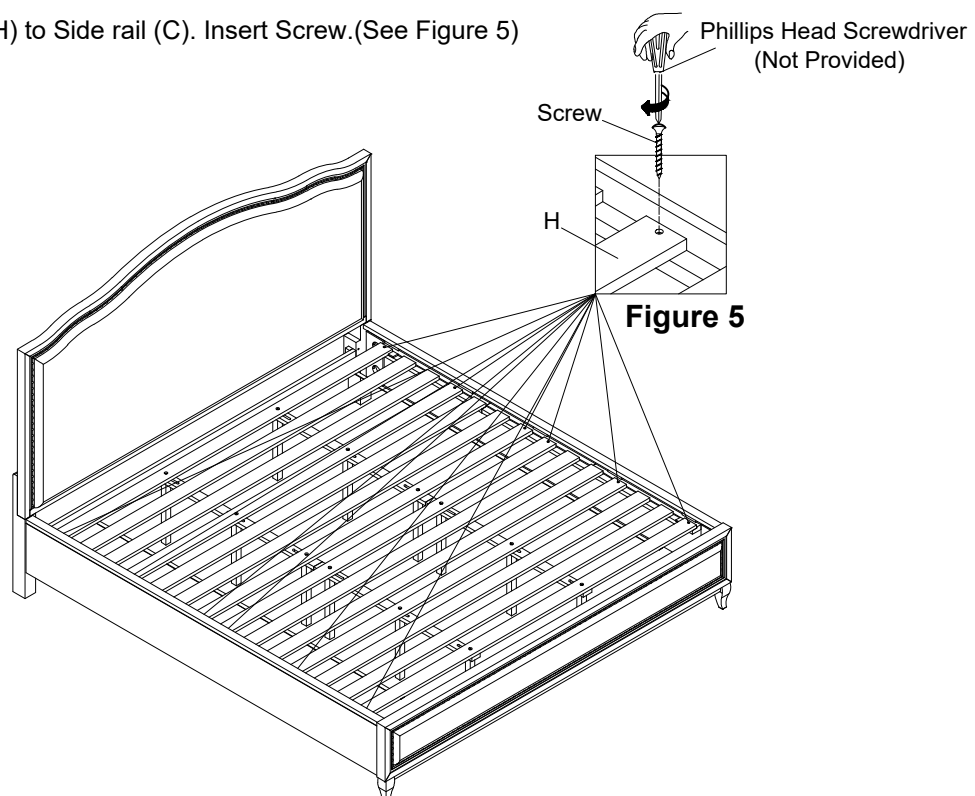

FLEXSTEEL®

Assembly Instructions 4/4

IMPORTANT NOTES

- Do not tighten up all the bolts until each part is properly assembled.
- Keep the Hex Key in a safe place as you may need to tighten up the bolts in the future.
- Use a soft cloth between these parts and the floor.
- We recommend this product be assembled by at least two adults.

STEP 6

Adjust the levelers on the Slat Supports (I) touching the floor. (See Figure 6)

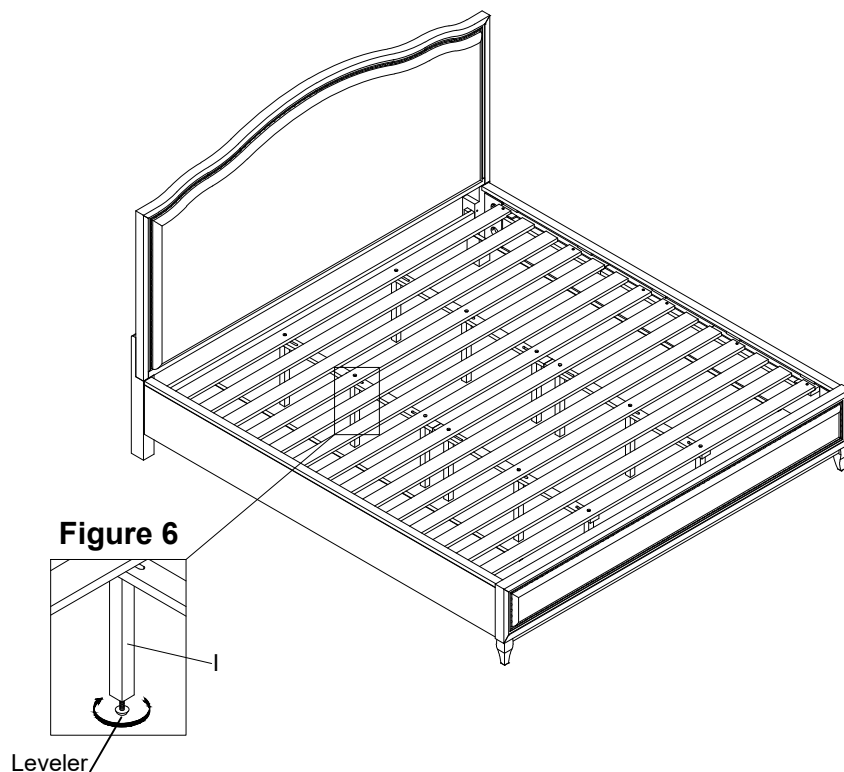

CARE INSTRUCTIONS

- To avoid scratches, do not place sharp or jagged objects directly on the bed.
- Do not place hot items directly on the bed.
- Avoid the use of harsh chemicals or abrasive cleaning materials.
- Wipe the bed clean with a soft, dry cloth after each use.
- Wipe up spills quickly with a soft, dry cloth.

Flexsteel Industries, Inc.

For Parts or Customer Service call

toll-free:

1-888-415-3979

Monday-Friday

8:00 a.m. -5:00 p.m.

(Central Time)

Email:

customersolutions@flexsteel.com

www.flexsteel.com

FLEXSTEEL®

W1042-860

Dresser

IMPORTANT

Carefully remove all parts from the carton, and put them individually on a soft cloth to prevent damage to the parts.

We have taken great care in the design of this product and request that you carefully and accurately follow our assembly instructions to ensure proper set-up.

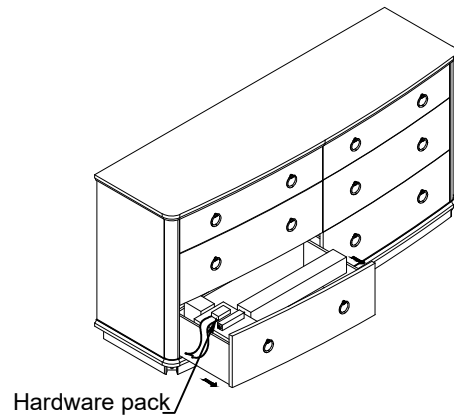
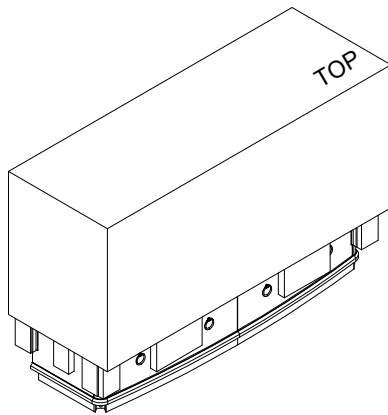
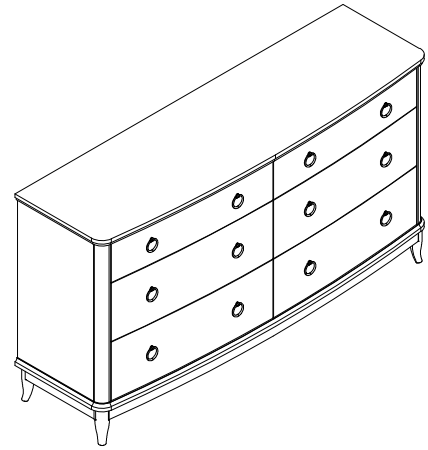

Part List

Assembly Instructions 1/3

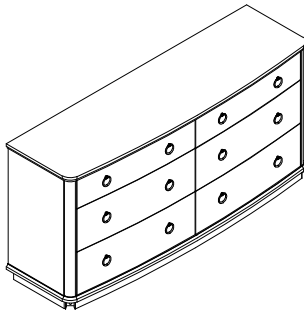

A. Dresser
1 piece



B. Leg
4 pieces



C. Support Leg
1 piece

Hardware List

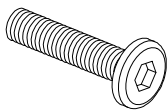

Bolt
Ø5/16" x 18 UNC x 1-3/4"
8 pieces



Spring Washer
Ø5/16" x 1.5mm
8 pieces



Flat Washer
Ø5/16" x Ø19 x 1.5mm
8 pieces

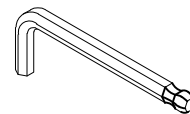

Hex Key
5/32"
1 piece

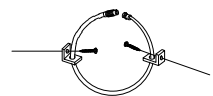

Anti-Tipping
1set

FLEXSTEEL®

Assembly Instructions 2/3

IMPORTANT NOTES

- Do not tighten up all the bolts until each part is properly assembled.
- Keep the Hex Key in a safe place as you may need to tighten up the bolts in the future.
- Use a soft cloth between these parts and the floor.
- We recommend this product be assembled by at least two adults.

STEP 1

Pull out the bottom drawer box to get out the assembly parts - legs (B) and support leg (C) . (See Figure 1)

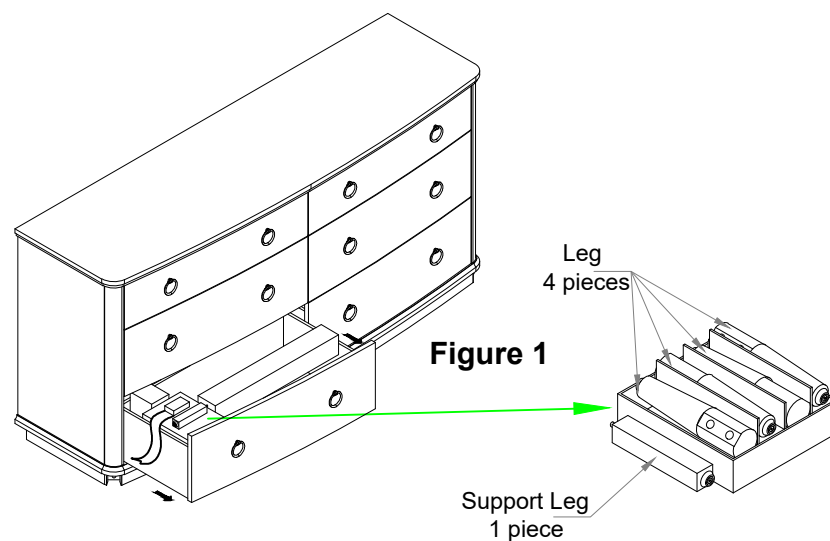

STEP 2

Fix Legs (B) to each corner of the Dresser (A). Insert Bolt, Spring Washer, Flat Washer and fully tighten bolts with Hex Key. (See Figure 2), Connect the Support Leg (C) to Dresser (A). (See Figure 3)

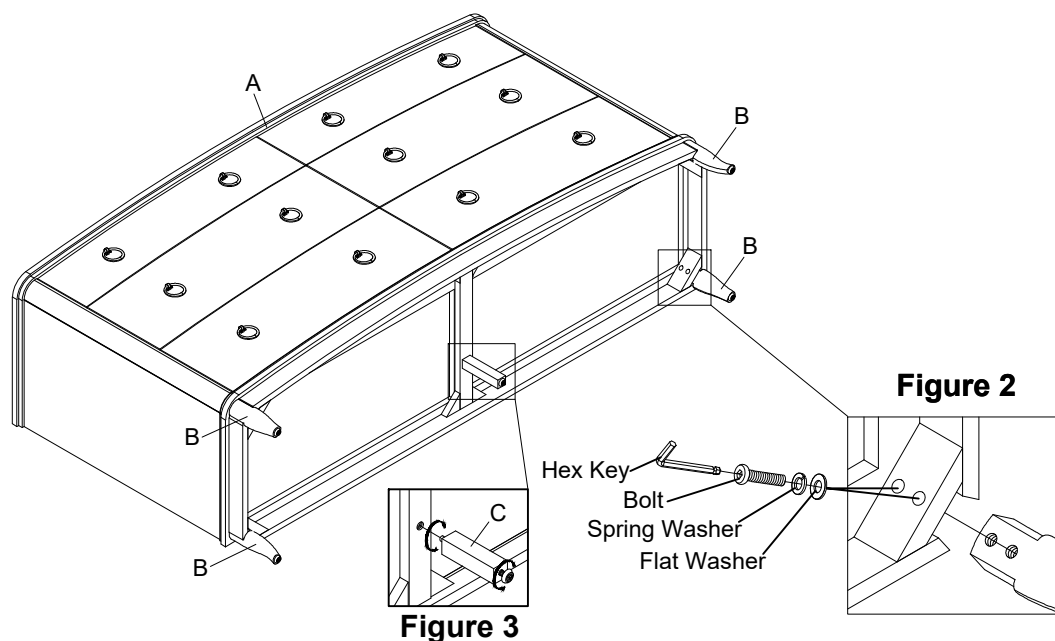

FLEXSTEEL®

Assembly Instructions 3/3

IMPORTANT NOTES

- Do not tighten up all the bolts until each part is properly assembled.
- Keep the Hex Key in a safe place as you may need to tighten up the bolts in the future.
- Use a soft cloth between these parts and the floor.
- We recommend this product be assembled by at least two adults.

STEP 3

Adjust the levelers on the legs until the furniture is leveled. (See Figure 4)

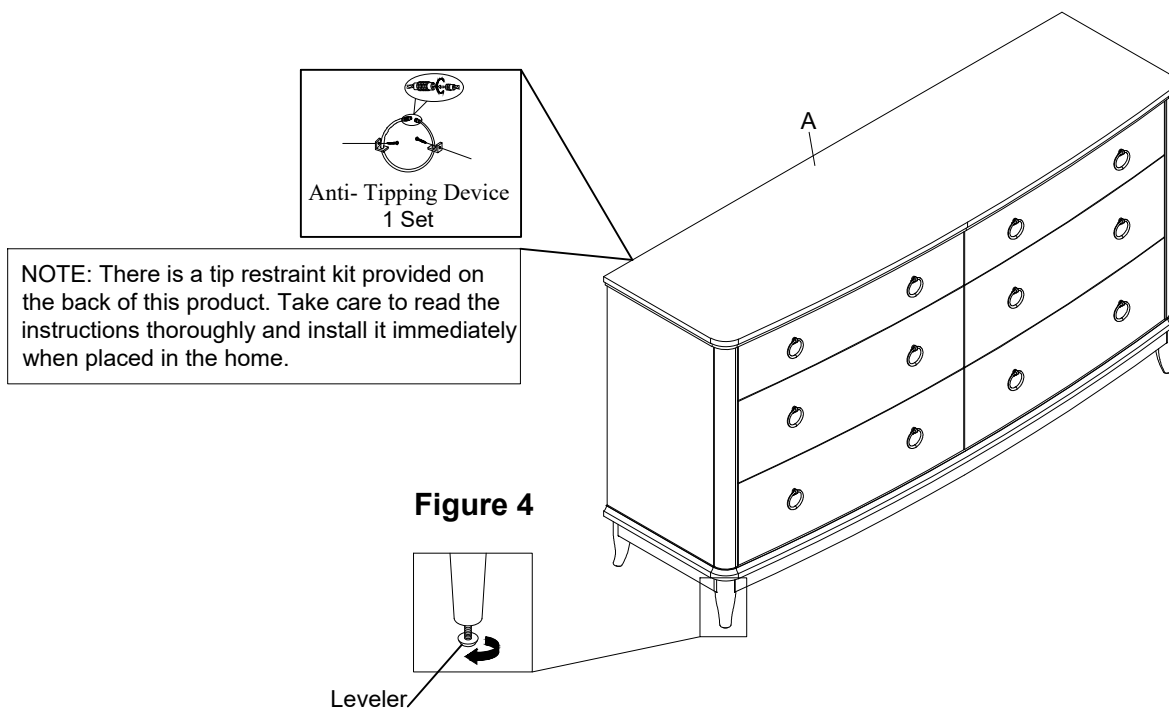

Figure 4

CARE INSTRUCTIONS

- To avoid scratches, do not place sharp or jagged objects directly on the cabinet.
- Do not place hot items directly on the cabinet.
- Use placemats or trivets under hot items and coasters under beverages to prevent marks and stains.
- Avoid the use of harsh chemicals or abrasive cleaning materials.
- Wipe the cabinet clean with a soft, dry cloth after each use.
- Wipe up spills quickly with a soft, dry cloth.

Flexsteel Industries, Inc.

For Parts or Customer Service call

toll-free:

1-888-415-3979

Monday-Friday

8:00 a.m. -5:00 p.m.

(Central Time)

Email:

customersolutions@flexsteel.com

www.flexsteel.com

FLEXSTEEL®

W1042-872

Chest

IMPORTANT

Carefully remove all parts from the carton, and put them individually on a soft cloth to prevent damage to the parts.

We have taken great care in the design of this product and request that you carefully and accurately follow our assembly instructions to ensure proper set-up.

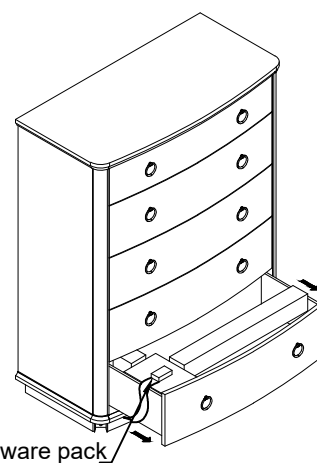
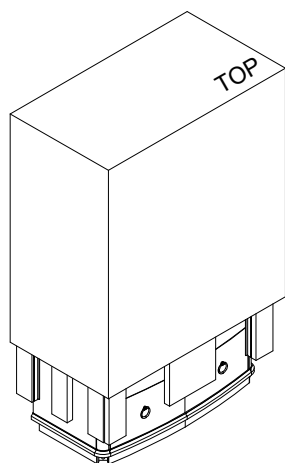
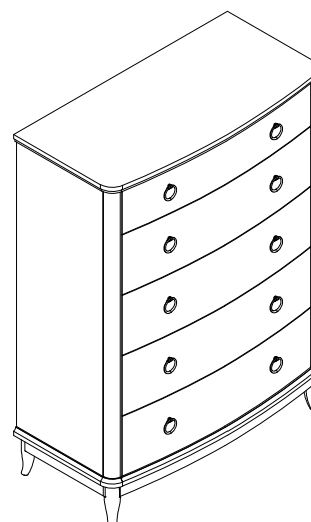

Hardware pack

Part List

Assembly Instructions 1/3

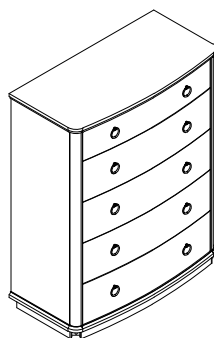

A. Box
1 piece



B. Leg
4 pieces

Hardware List

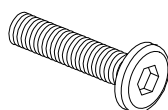

Bolt
Ø5/16" x 18 UNC x 1-3/4"
8 pieces



Spring Washer
Ø5/16" x 1.5mm
8 pieces



Flat Washer
Ø5/16" x Ø19 x 1.5mm
8 pieces

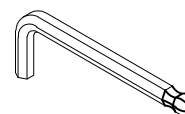

Hex Key
5/32"
1 piece

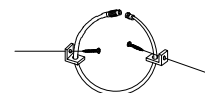

Anti-Tipping
1set

FLEXSTEEL®

Assembly Instructions 2/3

IMPORTANT NOTES

- Do not tighten up all the bolts until each part is properly assembled.
- Keep the Hex Key in a safe place as you may need to tighten up the bolts in the future.
- Use a soft cloth between these parts and the floor.
- We recommend this product be assembled by at least two adults.

STEP 1

Pull out the bottom drawer box to get out the assembly parts - legs (B). (See Figure 1)

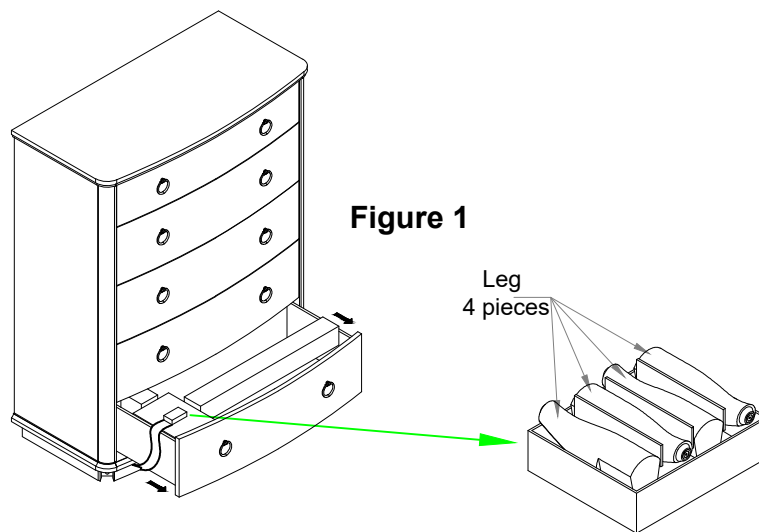

STEP 2

Fix Legs (B) to each corner of the Box (A). Insert Bolt, Spring Washer, Flat Washer and fully tighten bolts with Hex Key. (See Figure 2)

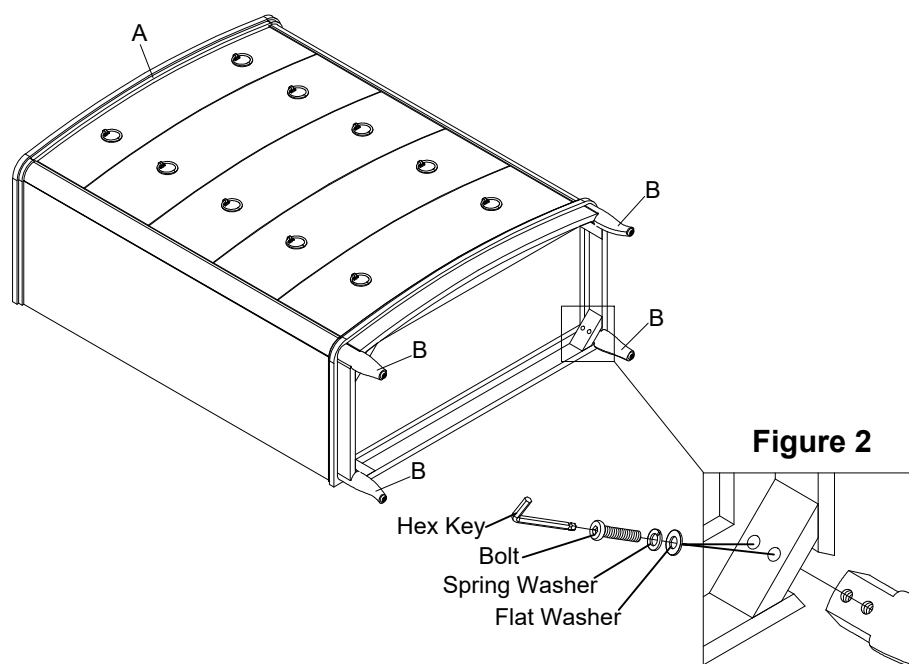

FLEXSTEEL®

Assembly Instructions 3/3

IMPORTANT NOTES

- Do not tighten up all the bolts until each part is properly assembled.
- Keep the Hex Key in a safe place as you may need to tighten up the bolts in the future.
- Use a soft cloth between these parts and the floor.
- We recommend this product be assembled by at least two adults.

STEP 3

Adjust the levelers on the legs until the furniture is leveled. (See Figure 3)

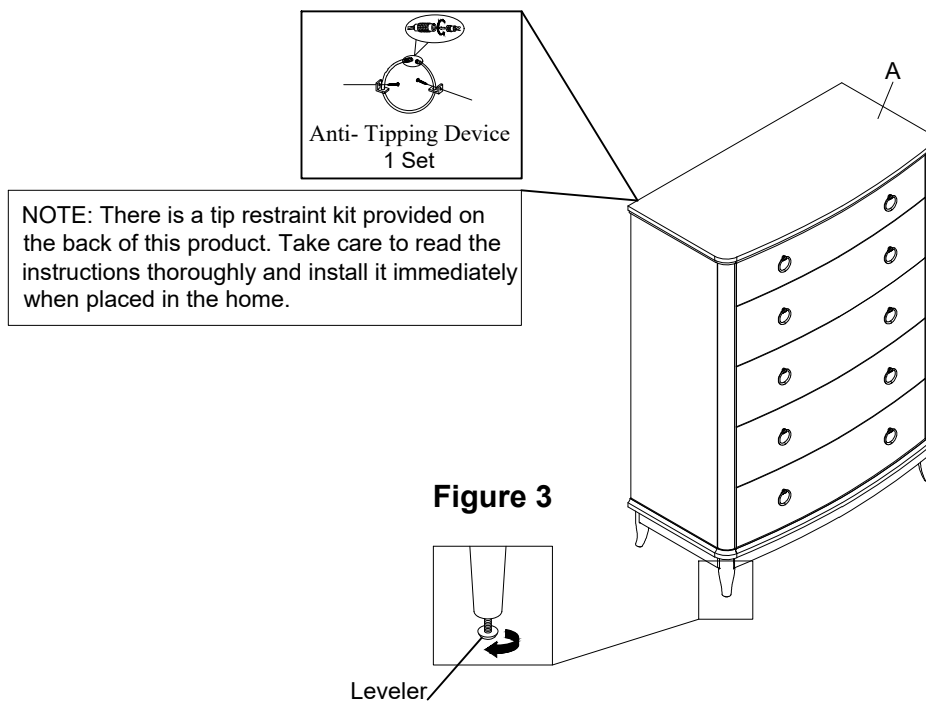

CARE INSTRUCTIONS

- To avoid scratches, do not place sharp or jagged objects directly on the cabinet.
- Do not place hot items directly on the cabinet.
- Use placemats or trivets under hot items and coasters under beverages to prevent marks and stains.
- Avoid the use of harsh chemicals or abrasive cleaning materials.
- Wipe the cabinet clean with a soft, dry cloth after each use.
- Wipe up spills quickly with a soft, dry cloth.

Flexsteel Industries, Inc.

For Parts or Customer Service call

toll-free:

1-888-415-3979

Monday-Friday

8:00 a.m. -5:00 p.m.

(Central Time)

Email:

customersolutions@flexsteel.com

www.flexsteel.com

FLEXSTEEL®

W1042-880

Mirror

IMPORTANT

Carefully remove all parts from the carton, and put them individually on a soft cloth to prevent damage to the parts.

We have taken great care in the design of this product and request that you carefully and accurately follow our assembly instructions to ensure proper set-up.

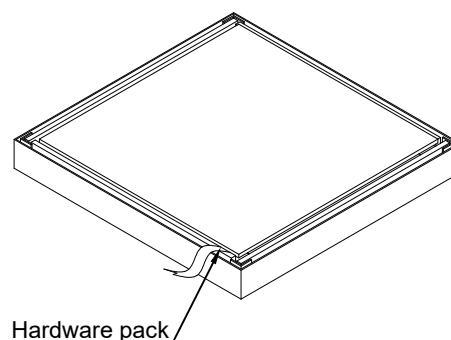
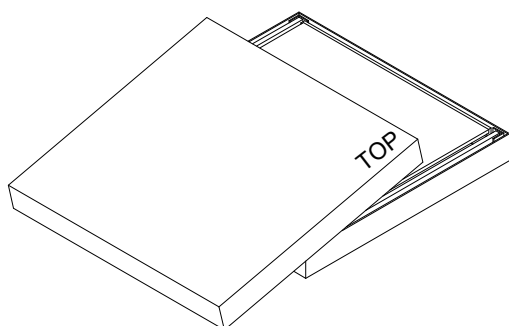
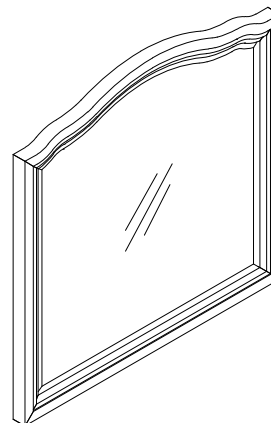

Part List

Assembly Instructions 1/2

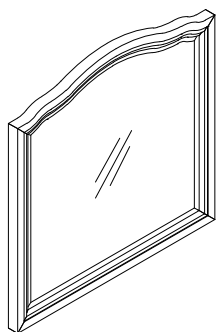

A. Mirror
1 piece



B. Mirror Support
2 pieces

Hardware List

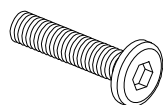

Bolt
Ø1/4" x 20 UNC x 1-1/2"
8 pieces



Spring Washer
Ø1/4" x 1.5mm
8 pieces



Flat Washer
Ø1/4" x Ø22 x 1.5mm
8 pieces

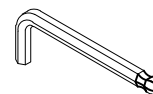

Hex Key
5/32"
1 piece

FLEXSTEEL®

Assembly Instructions 2/2

IMPORTANT NOTES

- Do not tighten up all the bolts until each part is properly assembled.
- Keep the Hex Key in a safe place as you may need to tighten up the bolts in the future.
- Use a soft cloth between these parts and the floor.
- We recommend this product be assembled by at least two adults.

STEP 1

Connect the Mirror Support (B) to Mirror (A) and Dresser. Insert Bolt, Spring Washer, Flat Washer and fully tighten bolts with Hex Key. (See Figure 1)

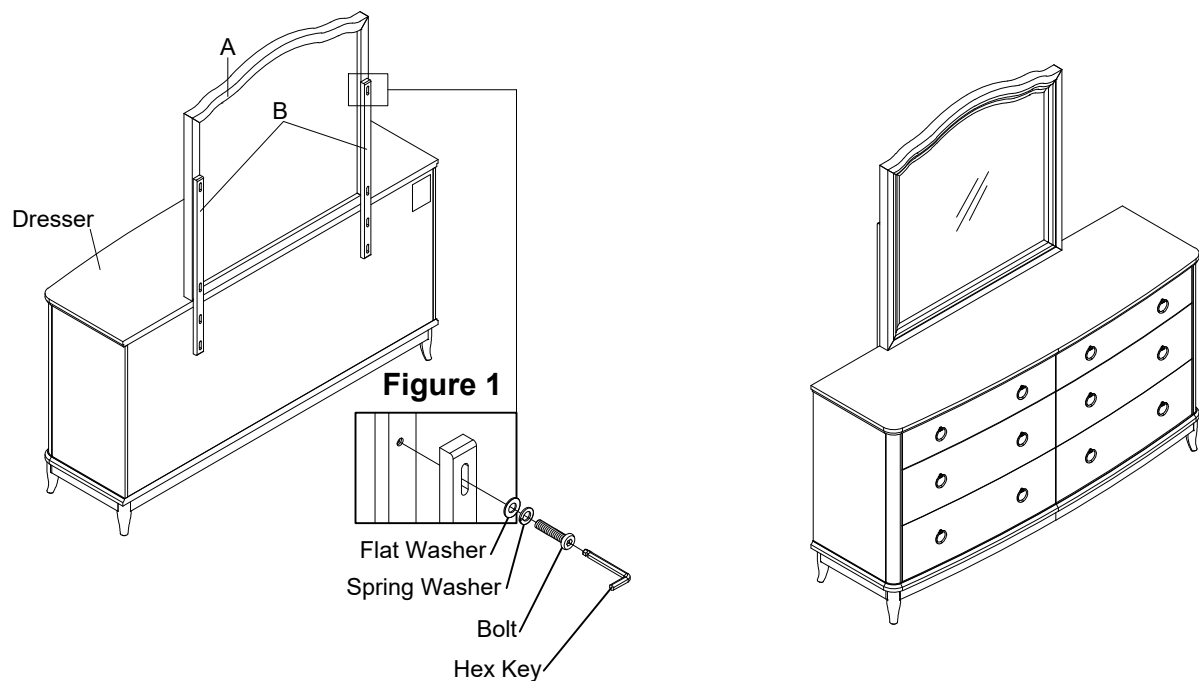

CARE INSTRUCTIONS

- To avoid scratches, do not place sharp or jagged objects directly on the cabinet.
- Do not place hot items directly on the mirror.
- Use placemats or trivets under hot items and coasters under beverages to prevent marks and stains.
- Avoid the use of harsh chemicals or abrasive cleaning materials.
- Wipe the mirror clean with a soft, dry cloth after each use.
- Wipe up spills quickly with a soft, dry cloth.

Flexsteel Industries, Inc.

For Parts or Customer Service call

toll-free:

1-888-415-3979

Monday-Friday

8:00 a.m. -5:00 p.m.

(Central Time)

Email:

customersolutions@flexsteel.com

www.flexsteel.com

FLEXSTEEL®

W1042-864

Open Nightstand

IMPORTANT

Carefully remove all parts from the carton, and put them individually on a soft cloth to prevent damage to the parts.

We have taken great care in the design of this product and request that you carefully and accurately follow our assembly instructions to ensure proper set-up.

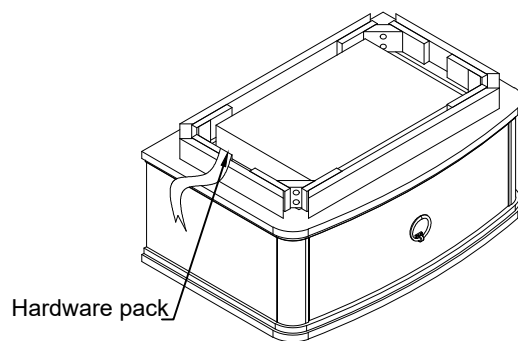
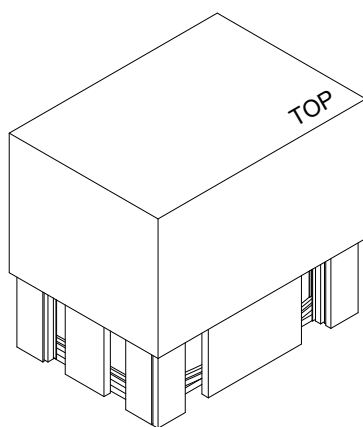
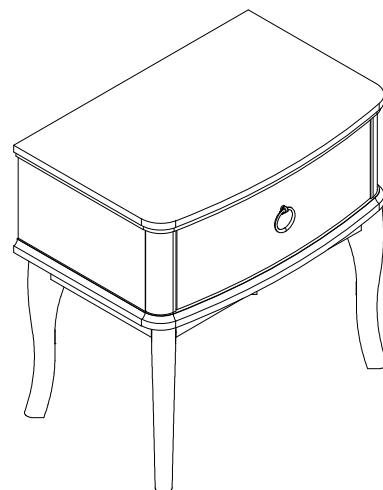

Part List

Assembly Instructions 1/3

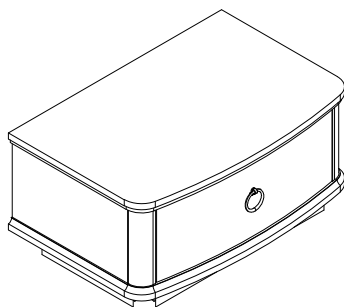

A. Box
1 piece



B. Leg
4 pieces

Hardware List

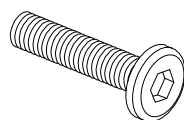

Bolt
Ø5/16" x 18 UNC x 2-3/8"
8 pieces



Spring Washer
Ø5/16" x 1.5mm
8 pieces



Flat Washer
5/16" x Ø19 x 1.5mm
8 pieces

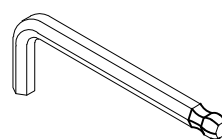

Hex Key
5/32"
1 piece

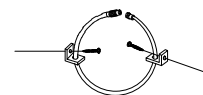

Anti-Tipping
1set

FLEXSTEEL®

Assembly Instructions 2/3

IMPORTANT NOTES

- Do not tighten up all the bolts until each part is properly assembled.
- Keep the Hex Key in a safe place as you may need to tighten up the bolts in the future.
- Use a soft cloth between these parts and the floor.
- We recommend this product be assembled by at least two adults.

STEP 1

Flip the Box (A) over to get out the assembly parts - legs (B). (See Figure 1)

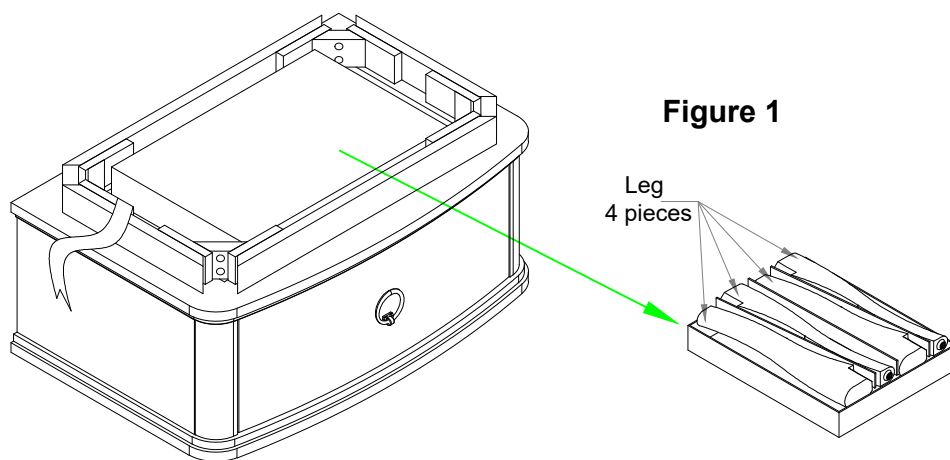

STEP 2

Fix Legs (B) to each corner of the Box (A). Insert Bolt, Spring Washer, Flat Washer and fully tighten bolts with Hex Key. (See Figure 2)

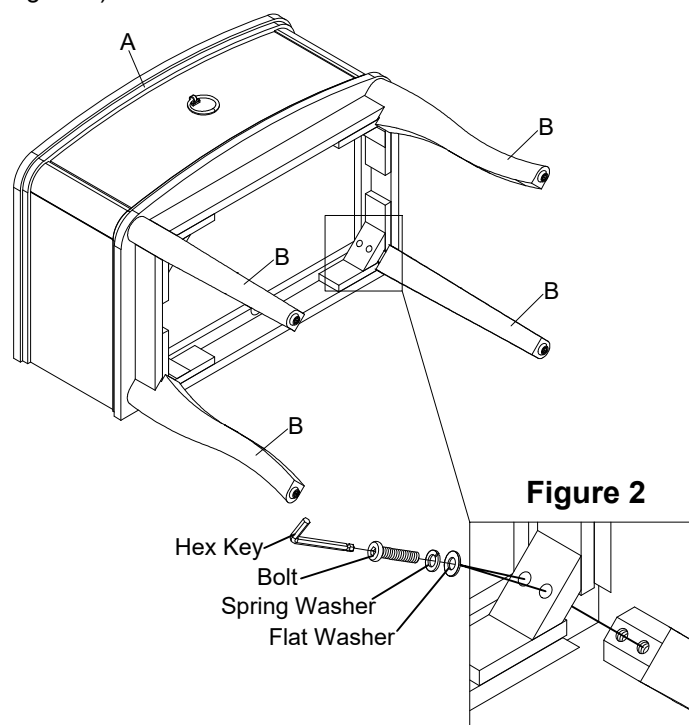

FLEXSTEEL®

Assembly Instructions 3/3

IMPORTANT NOTES

- Do not tighten up all the bolts until each part is properly assembled.
- Keep the Hex Key in a safe place as you may need to tighten up the bolts in the future.
- Use a soft cloth between these parts and the floor.
- We recommend this product be assembled by at least two adults.

STEP 3

Adjust the levelers on the legs until the furniture is leveled. (See Figure 3)

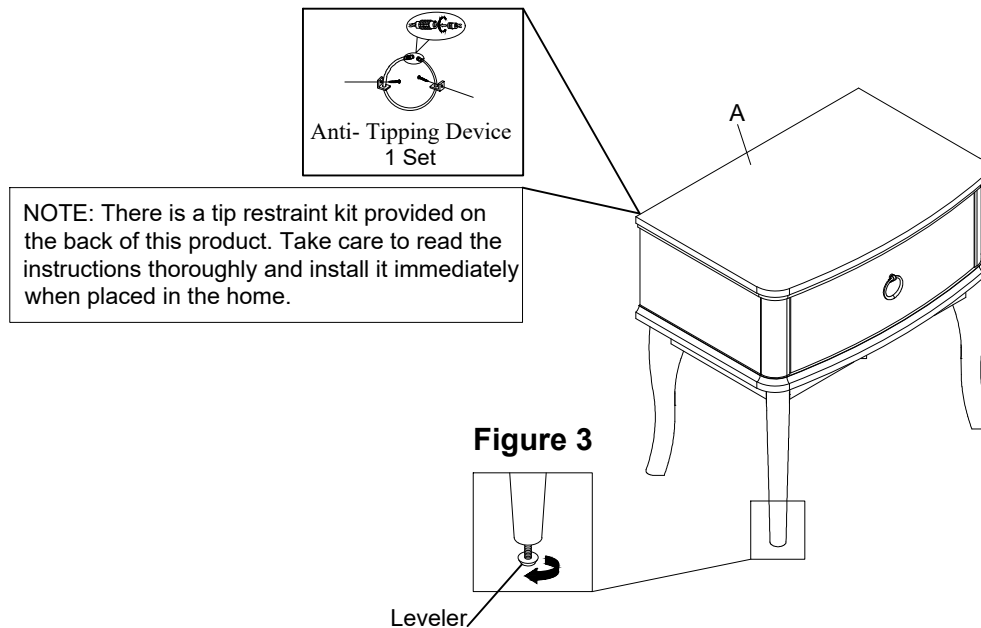

CARE INSTRUCTIONS

- To avoid scratches, do not place sharp or jagged objects directly on the cabinet.
- Do not place hot items directly on the cabinet.
- Use placemats or trivets under hot items and coasters under beverages to prevent marks and stains.
- Avoid the use of harsh chemicals or abrasive cleaning materials.
- Wipe the cabinet clean with a soft, dry cloth after each use.
- Wipe up spills quickly with a soft, dry cloth.

Flexsteel Industries, Inc.

For Parts or Customer Service call

toll-free:

1-888-415-3979

Monday-Friday

8:00 a.m. -5:00 p.m.

(Central Time)

Email:

customersolutions@flexsteel.com

www.flexsteel.com

FLEXSTEEL®

W1042-863

Nightstand

IMPORTANT

Carefully remove all parts from the carton, and put them individually on a soft cloth to prevent damage to the parts.

We have taken great care in the design of this product and request that you carefully and accurately follow our assembly instructions to ensure proper set-up.

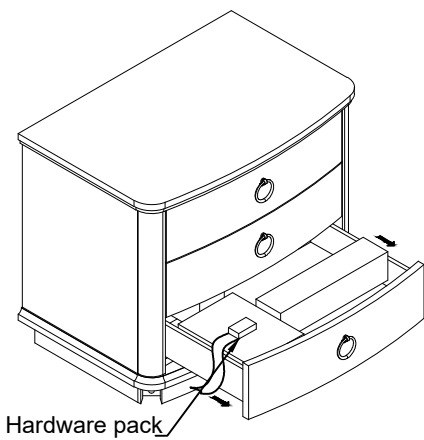
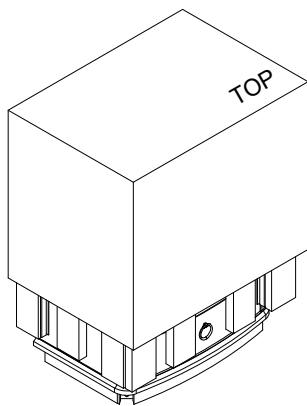

Hardware pack

Part List

Assembly Instructions 1/3

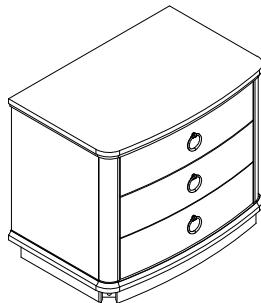

A. Box
1 piece



B. Leg
4 pieces

Hardware List

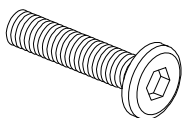

Bolt
Ø5/16" x 18 UNC x 1-3/4"
8 pieces



Spring Washer
Ø5/16" x 1.5mm
8 pieces



Flat Washer
Ø5/16" x Ø19 x 1.5mm
8 pieces

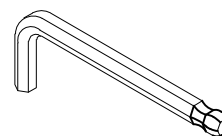

Hex Key
5/32"
1 piece

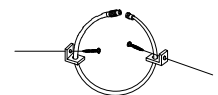

Anti-Tipping
1set

FLEXSTEEL®

Assembly Instructions 2/3

IMPORTANT NOTES

- Do not tighten up all the bolts until each part is properly assembled.
- Keep the Hex Key in a safe place as you may need to tighten up the bolts in the future.
- Use a soft cloth between these parts and the floor.
- We recommend this product be assembled by at least two adults.

STEP 1

Pull out the bottom drawer box to get out the assembly parts - legs (B). (See Figure 1)

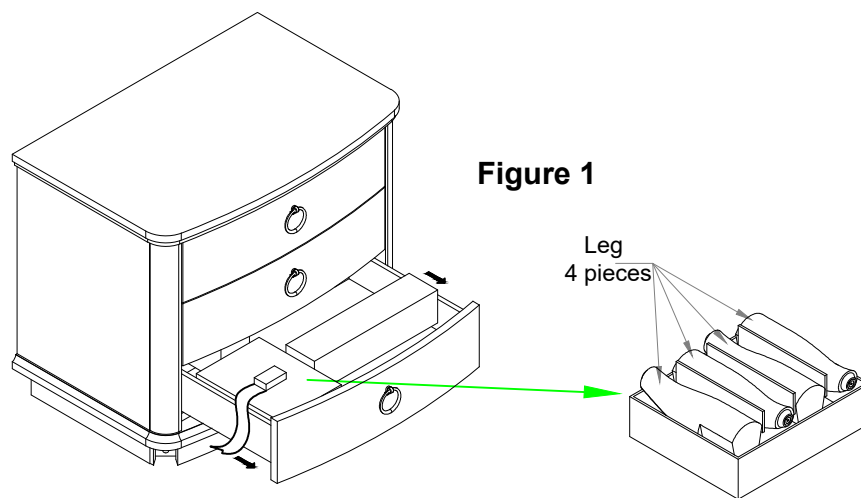

STEP 2

Fix Legs (B) to each corner of the Box (A). Insert Bolt, Spring Washer, Flat Washer and fully tighten bolts with Hex Key. (See Figure 2)

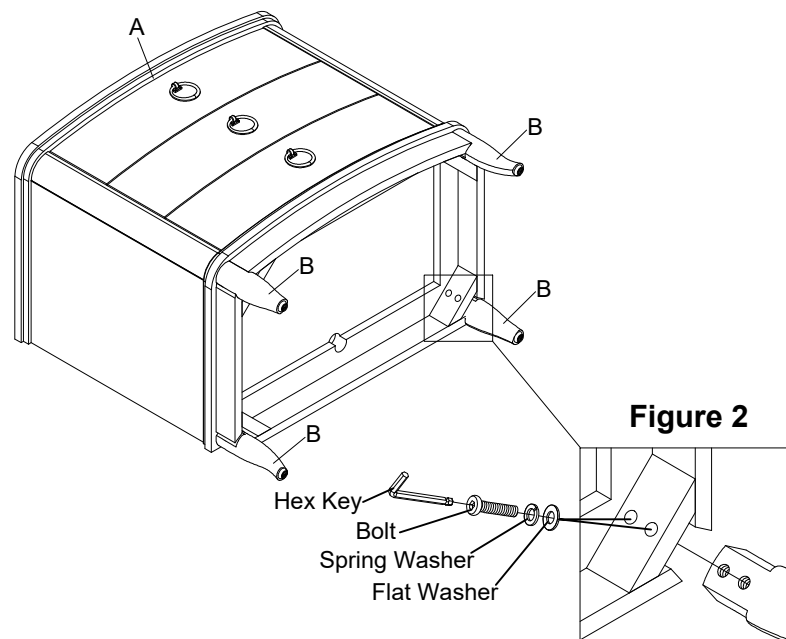

FLEXSTEEL®

Assembly Instructions 3/3

IMPORTANT NOTES

- Do not tighten up all the bolts until each part is properly assembled.
- Keep the Hex Key in a safe place as you may need to tighten up the bolts in the future.
- Use a soft cloth between these parts and the floor.
- We recommend this product be assembled by at least two adults.

STEP 3

Adjust the levelers on the legs until the furniture is leveled. (See Figure 3)

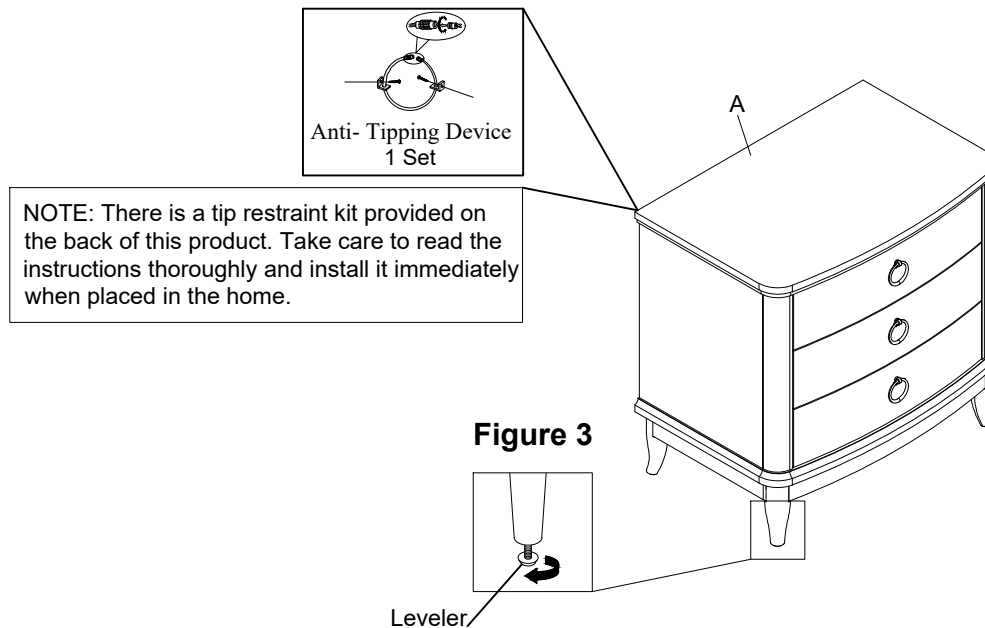

CARE INSTRUCTIONS

- To avoid scratches, do not place sharp or jagged objects directly on the cabinet.
- Do not place hot items directly on the cabinet.
- Use placemats or trivets under hot items and coasters under beverages to prevent marks and stains.
- Avoid the use of harsh chemicals or abrasive cleaning materials.
- Wipe the cabinet clean with a soft, dry cloth after each use.
- Wipe up spills quickly with a soft, dry cloth.

Flexsteel Industries, Inc.

For Parts or Customer Service call

toll-free:

1-888-415-3979

Monday-Friday

8:00 a.m. -5:00 p.m.

(Central Time)

Email:

customersolutions@flexsteel.com

www.flexsteel.com