



32QUART DIGITAL AIR FRYER TOASTER OVEN



BAF-802

**REGISTER
NOW!**

for an additional
**3 months
Warranty**

As a special thank-you for registering your Beelicious unit, you'll automatically receive an additional 3 months added to your limited manufacturer's warranty!

All you need to do is send your Amazon order ID to our Email: support@beelicious.shop.

This warranty only cover orders from authorized brand online stores and our official website. We are not responsible for any purchases from other distribution channels.



FREE upgrade to FULL Replacement Guarantee - no need to return.



Once registered, you will be ensured that if anything goes wrong with your product, we will either send you a brand new unit as a replacement (Absolutely FREE) or provide a FULL refund of your order.



Just send your Order ID to Email support@beelicious.shop or enter your order number online at www.beelicious.shop/?vipwarranty to activate the extended warranty.



◀ Scan code to activate extended warranty online.

Scan this QR code to get the installation video. ▶



NOTE: Must register within 7 days after receiving your new product.

CONTENTS

Important safeguards	6
Getting to know your air fryer toaster oven	8
• Main components	8
• Features	9
• Technical specifications	9
• Control panel	10
Before using your air fryer toaster oven	13
Operation guide	14
Dual cook operation guide	17
Toast cooking guide	20
Rotisserie cooking guide	21
Preset chart	23
Dual cook functions quick reference chart	26
Replacing the light	27
Care, cleaning & storage	28
Troubleshooting	30

IMPORTANT SAFEGUARDS

Always follow basic safety precautions when using your Air Fryer Toaster Oven.

READ ALL INSTRUCTIONS BEFORE USE

- Unplug from outlet when not in use and before cleaning. Allow to cool before cleaning or handling, putting on or taking off parts.
- Do not touch hot surfaces without using heat-protective gloves. To avoid burns, use extreme caution when removing hot accessories or disposing of hot grease.
- Do not immerse cord, plug or any parts of Air Fryer Toaster Oven in water or other liquid to prevent against electrical hazard.
- To avoid potential hazards, please do not put the product next to or used by children.
- Do not operate any appliance with a damaged cord or plug. If the appliance is dropped or damaged, please return product to original store or retailer for proper inspection and repair.
- To avoid potential injury, do not use accessories or attachments not recommended for the unit.
- Do not use outdoors.
- Do not let the cord hang over the edge of a surface where the potential of child or pet interaction is present.
- Do not place on or near a hot gas or electric burner.
- Do not use this appliance for other than intended use.
- Extreme caution should be exercised when using containers constructed of materials other than metal or glass in the Air Fryer Toaster Oven.
- Do not store any materials other than manufacturer's recommended accessories in this appliance when not in use.
- Do not place any of the following materials in this appliance: cardboard, plastic, paper, or anything similar.
- Oversized foods and utensils must not be inserted in an Air Fryer Toaster Oven as they may involve a risk of fire or electric shock.

IMPORTANT SAFEGUARDS

- A fire may occur if the appliance is covered or touching flammable materials such as curtains, draperies or walls when in operation.
- Do not store any items on top of the appliance when in operation.
- Do not clean with metal scouring pads. Pieces can break off the pad and touch electrical parts, involving a risk of electric shock.
- Warning: To avoid possibility of fire, Never leave the appliance unattended during use. Use recommended temperature settings for all function.
- Do not rest cooking utensils or baking dishes on glass door.
- Do not operate your appliance in an appliance garage or under a wall cabinet. When storing in an appliance garage, always unplug the unit from the electrical outlet.
- Check if the voltage indicated on the appliance corresponds to the local main voltage before connecting the appliance.

**FOR HOUSEHOLD USE ONLY
SAVE THESE INSTRUCTIONS**

GETTING TO KNOW YOUR AIR FRYER TOASTER OVEN

MAIN COMPONENTS



Oven Rack



Air Fryer Basket



Baking Pan



Rotisserie Lift



Rotisserie Spit and Fork



Oven Rack

Used for meat, bread, pizza etc.

Air Fryer Basket

Use the Air Fryer Basket in conjunction with the Air Fry function to optimize your cooking results. Used for fries, chicken wings, onion etc. It also could be used as the dehydrate basket.

Baking Pan

Used for cookies, cake, turkey etc. It can also hold the drippings from the food or oil when Airfrying.

Rotisserie Spit and Fork

Used for chicken, meat. (The rotisserie spit and fork needs to distinguish left and right, please refer to page 21).

Rotisserie Lift

Used to remove the rotisserie from the oven.

FEATURES

By using all-new 360° HOT AIR CIRCULATION technology, The Air Fryer Toaster Oven can offer you more delicious and healthier cuisine.

DOOR SENSOR

If the door is opened during cooking, the cooking will pause and the light will turn on. The panel will show . When the door is closed, the light will turn off and resume cooking. Please make sure to keep the oven door closed during cooking.

TECHNICAL SPECIFICATIONS

Voltage	Power	Frequency	Capacity
120V	1800W	60Hz	32QT

CONTROL PANEL

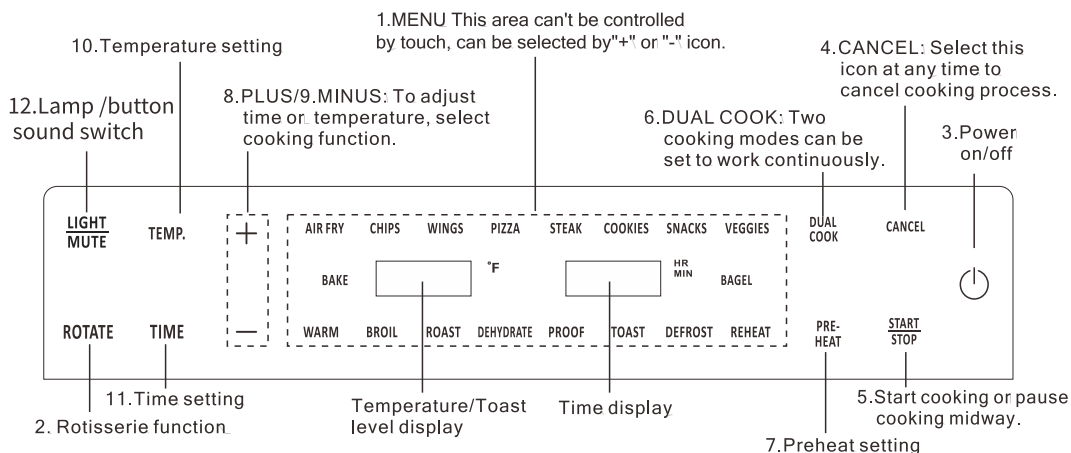

1. MENU

- ① Can't directly select menu through touch icons. You need to select the menu through '-' and '+' signs on the left.
- ② Long press '-' and '+' signs to speed up.
- ③ During process of setting temperature and time, two digital screens will flash for 5 seconds, and after 5 seconds of no operation, it will automatically exit and stop flashing.

• AIR FRY AIR FRY

Air frying can be used as a healthy alternative style of cooking, requiring little to no oil and using rapid hot air to cook meals faster.

• ROTISSERIE FUNCTION ROTATE

Use the rotisserie spit and its handle to cook whole chickens and roast all types of food.

• TOAST TOAST

Use the toast function to toast bread to perfection: crunchy on the outside and soft on the inside, For detailed operation instruction, please see page 20.

• BAKE BAKE

Recommended for foods that would normally be prepared in a conventional oven.

• BROIL BROIL

Used for meats such as beef, chicken, or pork. Also used for top browning casseroles and gratins.

• ROAST ROAST

Roasting can be used to enhance flavor through caramelization and browning on the surface, leaving food moist and juicy on the inside.

CONTROL PANEL

- **DEHYDRATE** DEHYDRATE
Cooks food convection style on low heat, allowing many types of food to be preserved. Great for drying fruit, vegetables and meats (beef jerky).
- **PROOF** PROOF
Proofing can be used to prepare bread, pizza dough and yogurt.
- **DEFROST** DEFROST
Use to melt ice of food
- **REHEAT** PRE-HEAT
Warm up leftovers without overcooking or drying out the food.
- **WARM** WARM
Use to hold food at a desired temperature (90-250° F) for a period of time.
- **CHIPS** CHIPS
Recommended for frozen chips.
- **WINGS** WINGS
Recommended for defrost chicken wings.
- **PIZZA** PIZZA
Perfect for cooking homemade or frozen pizza. Crisps the dough while melting the cheese from the top.
- **STEAK** STEAK
Recommended for fresh steak.
- **COOKIES** COOKIES
Great for fresh homemade cookies.
- **SNACKS** SNACKS
Recommended for frozen fried food such as chicken nuggets, popcorn chicken.
- **VEGGIES** VEGGIES
Recommended for fresh or frozen vegetables.
- **BAGEL** BAGEL
Used for homemade bagel or thicker bread.

CONTROL PANEL

2. ROTATE

Use the rotisserie spit and its handle to cook whole chickens and roast all types of food. For detailed operation instruction, please see page 21-22.

3. POWER ON/OFF

Select "POWER ON/OFF" icon to turn the Air Fryer Toaster Oven On/Off.

4. CANCEL

Select this icon at any time to cancel the cooking process, oven will back to just-power-on statue.

5. START/STOP

Select "START/STOP" icon to start or stop the program.

6. DUAL COOK

Advanced dual function cooking technology allows you to program your Air Fryer Oven to start cooking with one preset, then automatically transition to a second preset for a perfect cook on any meal. For detailed operation, please see page 17-19.

7. PREHEAT

After selecting a program and adjusting the temperature, touch "PREHEAT" icon to preheat the Air Fryer Toaster Oven. After preheating, the oven will beep 1 time and "Add food" will be showed on the display. Put food item in the oven, select "START/STOP" icon, cooking program will begin.

8. PLUS +

Select this icon to select the menu or adjust the time and temperature.

9. MINS —

Select this icon to select the menu or adjust the time and temperature.

10. TEMP.

Temperature icon

11. TIME

Time icon

12. LIGHT/MUTE

Select 'LIGHT/MUTE' icon to turn the oven light On/Off. (After manual selection, it will automatically turn off 5 minutes later.)
Long press the 'LIGHT/MUTE' icon for 2s, to turn the button sound On/Off.

BEFORE USING YOUR AIR FRYER TOASTER OVEN

- 1** Remove all packaging around and inside the oven.

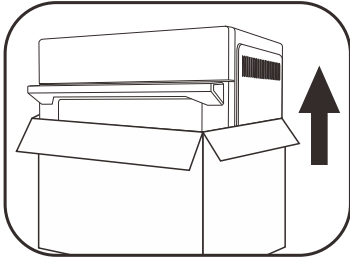

- 2** Place on a stable, level, heat-resistant surface, away from anything that can be damaged by heat. Keep at least 4 inches distance between the electrical outlet and the wall, furniture, etc.

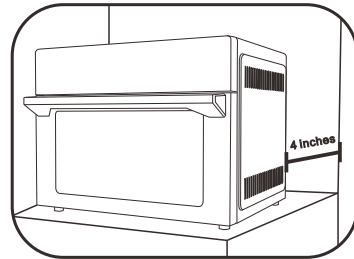

- 3** Remove the protective film from the control panel. (This film is to protect the panel, you can tear it off or keep it.)

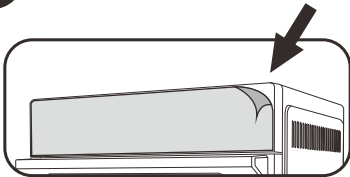

- 4** Wash all accessories and clean the interior of the Air Fryer Toaster Oven. Dry and place accessories back in oven.

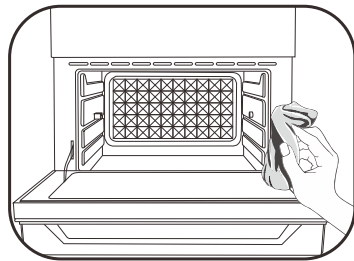

- 5** Before use, ensure that the power and outlet meet the requirements to operate this product (input power requirements).

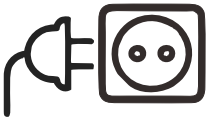

- 6** Upon first use, it is necessary to run the oven for 18 minutes at the highest temperature (450°F) in order to sterilize and remove any manufacturing odor. The Air fryer Toaster Oven may emit an odor or smoke due to the heater's protective film.

OPERATION GUIDE



POWER ON

Plug in, **select** POWER ON/OFF icon to turn on the Air Fryer Toaster Oven, screen will illuminate and "AIR FRY" icon will **flash**.



Select a cooking program setting, Please reference preset chart in page 23-25, adjust temperature and time setting according to food type and food weight.

Note:

1. Temperature on the "Toast" function cannot be adjusted. Touch the "TEMP." or "TIME" icon can select level 1 level 7 of toast by plus or minus icon. For detailed operation, please check page 20.

2. Touch " ROTATE " icon can set rotisserie program directly. This program need to use rotisserie fork and spit, rotisserie lift. Please check Step by Step Operation uide in page 21-22.

OPERATION GUIDE

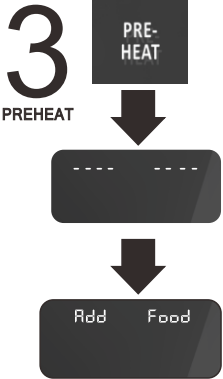

Select the "PREHEAT" icon in order to preheat the Air Fryer Toaster Oven. When internal temperature reaches 300°F, "Add Food" signal will be shown on display. After preheating, put the food in oven and close the door, select "START/STOP" icon to start cooking.

Note: TOAST, DEHYDRATE, PROOF, DEFROST, REHEAT, and WARM programs do not require preheating, please select "START/STOP" icon to start cooking directly.

4 ACCESSORIES POSITION

1. Insert accessories with food in recommend position according to overview diagram in page 23-25, then close the door.

2. **Note:** If you need to use rotisserie fork, fix food and place it in air fryer oven as page 21-22.

CAUTION: Be careful when putting food in the oven after preheating, wearing gloves can help to prevent getting burnt.

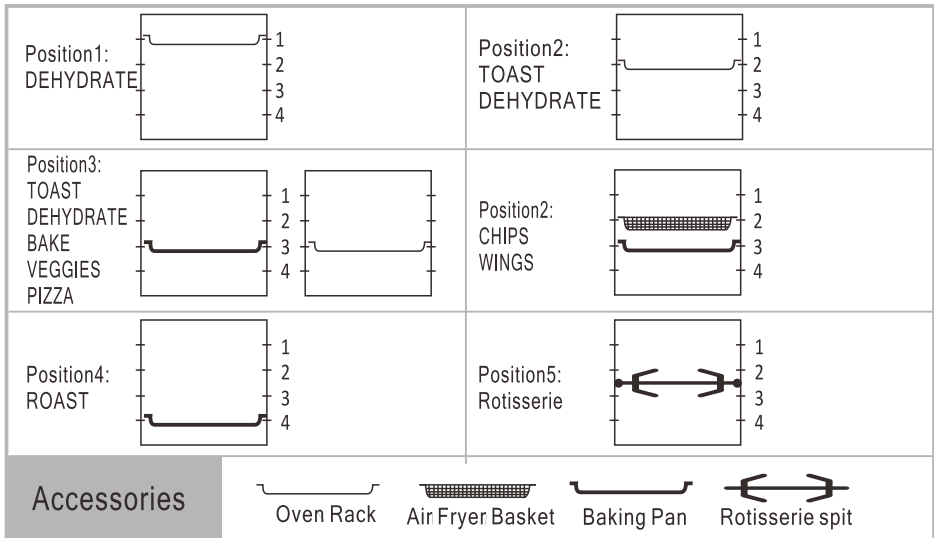

Note: When cooking greasy foods (e.g. chicken wings) with the oven rack, air fryer basket or rotisserie spit and fork, place baking pan underneath can prevent oil from dripping on the bottom heating element.

OPERATION GUIDE

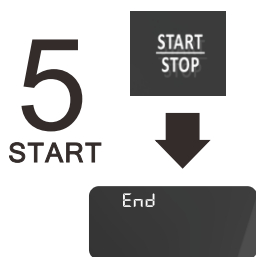

If you skip the preheat function of step 3, please select the START/STOP icon to begin cooking, and the display will show the timer counting down, When cooking is done, the oven will beep 3 times, the display will show "END " and all menu icons will light up.

Note:

1. The display will continue to show "END" until other icon has been selected. After cooking program completed, fan will continue to run for 4 minutes in order to properly cool the appliance if inner temperature reaches 390°F. If any icon on control panel is selected or touched, cooling program will automatically terminate.
2. **START/STOP** : Select "START/STOP" icon, you can start cooking program or pause midway during cooking.
3. **CANCEL**: Select "CANCEL" icon can cancel cooking process and get back to power-on state.
4. **Open door or close door manually**: If the door is opened midway during cooking, oven will stop working until the door is closed.

DUAL COOK OPERATION GUIDE



1 POWER ON

Plug in, select POWER ON/OFF icon to turn on the Air Fryer Toaster Oven, screen will illuminate and "AIR FRY" icon will flash.

2 MENU SELECT AND SETTING

- ① Start program.
- ② Select the first function.



- ③ Adjust time and temperature of the first function.
- ④ Confirm the first program and start the second program setting.



- ⑤ Select the second function.
- ⑥ Adjust time and temperature of the second function.
- ⑦ Confirm the second program.

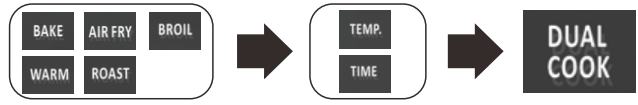

First step: Select "DUAL COOK" to start the program, The oven will display 5 available functions for the first cooking cycle: AIR FRY/BAKE/BROIL/ROAST/WARM.

select the desired one then set temperature and time for this function by using "TEMP." and "TIME" icon. Click "DUAL COOK" again to confirm the first program and start to set the second cooking program.

Second Step: The rest available functions will light up, choose the desired function and set temperature and time. select "DUAL COOK" when the second program is confirmed. Screen will show both two chosen cooking programs, "START/STOP" icon will flash.

DUAL COOK OPERATION GUIDE

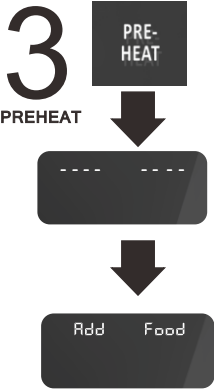

Preheat is an optional setting. When STEP 2 is completed, if you want to skip preheat setting, you can click "START/STOP" icon, cooking will start directly. Screen will show the first program setting. When the first cooking program completed, the oven will continue the second program automatically, and the screen will display the second program setting. If you don't want to skip preheating, you can select "PREHEAT" icon, preheating will begin. When it's completed, select "START/STOP" icon.

OPERATION

Touch the "PREHEAT" icon in order to preheat the Air Fryer Toaster Oven. When the internal temperature reaches 300°F, which usually takes about 2-3 minutes, the "Add Food" signal will appear.

CAUTION: Be careful when putting food in the oven after preheating, wearing gloves can help to prevent getting burnt.

4 ACCESSORIES POSITION

1. Insert accessories with food in recommend position according to overview diagram as below, then close the door.

2. **Note:** If you need to use rotisserie fork, fix food and place it in air fryer oven as page 21-22.

CAUTION: Be careful when putting food in the oven after preheating, wearing gloves can help to prevent getting burnt.

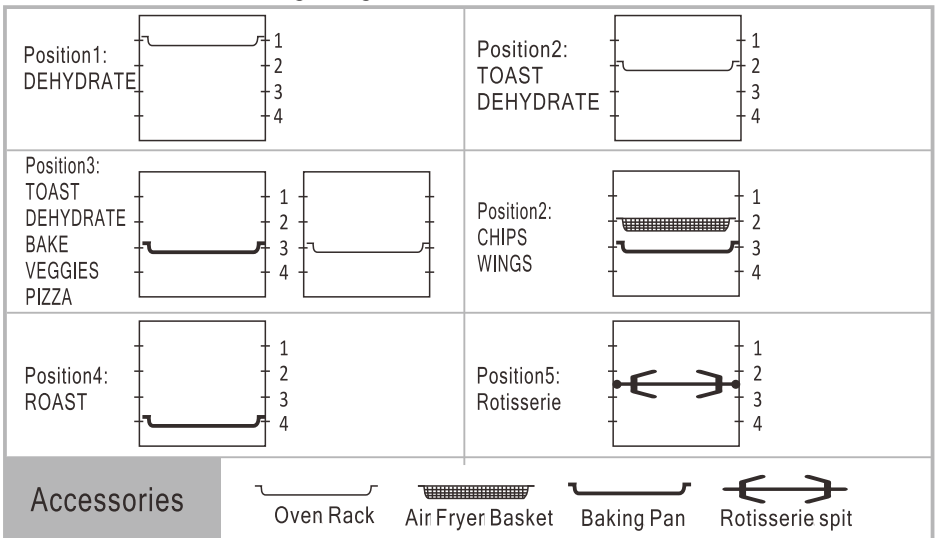

Note: When cooking greasy foods (e.g. chicken wings) with the oven rack, air fryer basket or rotisserie spit and fork, place baking pan underneath can prevent oil from dripping on the bottom heating element.

DUAL COOK OPERATION GUIDE

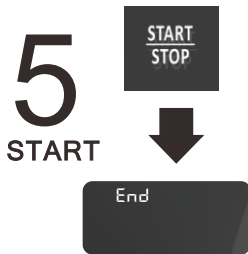

Please select "START /STOP" icon to begin cooking, the first program will start, and the second selected program will not be displayed until the first program is completed.

When 2 cooking programs are completed, oven will beep 3 times, display will show "END", and all menu icons will light up.

Note:

1. If you want to quit "DUAL COOK" function, please click "CANCEL" icon, oven will back to power-on state.
2. After cooking program completed, fan will continue to run for 4 minutes in order to properly cool the appliance if inner temperature reaches 390°F.
3. **" START/STOP" :** Select "START/STOP" icon, you can start cooking program or pause midway during cooking.
4. **" CANCEL" :** Select "CANCEL" icon can cancel cooking process and get back to power-on state.
5. **Open door or close door manually:** If the door is opened midway during cooking, oven will stop working until the door is closed.

TOAST COOKING GUIDE

- 1 Toast function is set with 7 levels of cooking effects, which can be adjusted by "TIME" and "TEMP." icons.

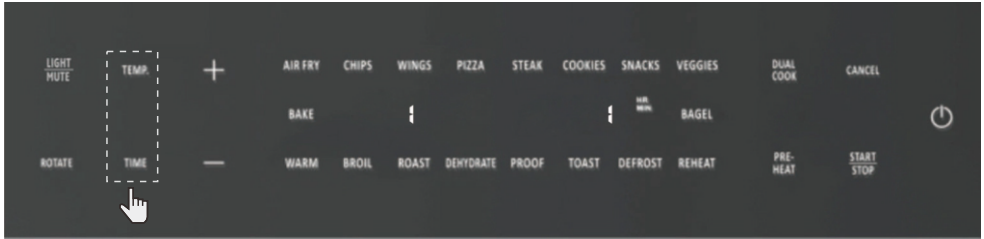

- 2 "1 level" is the mildest cooking effect, while "7 level" is the most crispy result, below Toast cooking chart for the reference.

Note : In Toast function, only 7 preset cooking levels can be selected.

LEVEL	COOK TIME	RECOMMEND TOAST QUANTITY
1 (LIGHTEST)	1 MIN	5-6 SLICES
2	2 MINS	
3	3 MINS	
4	4 MINS	
5	5 MINS	
6	6 MINS	
7(DARKEST)	7 MINS	

- 3 Use oven rack and put in the second groove position(count from top to bottom). Suggested toast quantity for one layer is 6 pieces. If you select same level but use less quantity, cooking effect will be darker. It is recommended to use 5-6 slices toast in one layer, or lower the level setting for less than 6 pieces of toast cooking.

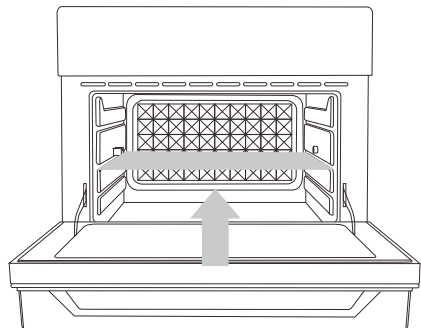
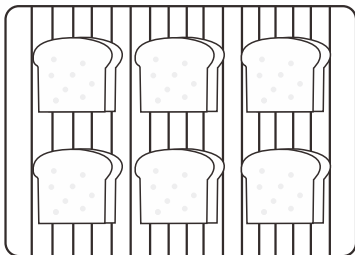

ROTISSERIE COOKING GUIDE

CAUTION: Always be careful when insert rotisserie accessories and food into the cooking chamber before preheating the oven. Operating with gloves can avoid burns better.

1 To use the Rotisserie Spit and Forks

Remove the forks and screws from the package.

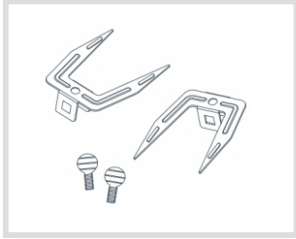

2 Please pay attention to distinguish the left and right of the rotisserie spit and fork.

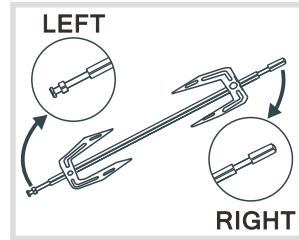

3 Use kitchen twine tie up the food item, push the food item onto the spit.

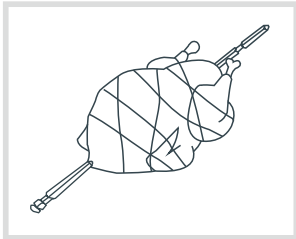

4 Slide the forks onto both ends of the spit, ensuring the prongs are inserted into the food item, Tighten the setting screws until are secure.

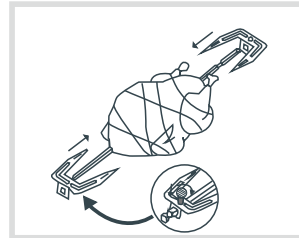

5 Select "ROTATE" function, use "TEMP." and "TIME" icons to adjust cooking temperature and time as desired.

Note: Default time/default temperature are 30 mins/400°F, which is for 1000-1500g (2.2-3.3lbs) food item.

6 Select "PREHEAT" icon (optional step). Put the food item into oven when the program is completed.

Note: Preheating is an optional step, it can be skipped to STEP 7.

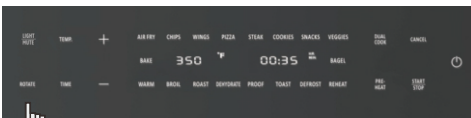
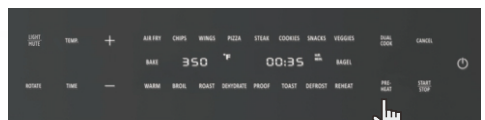

ROTISSERIE COOKING GUIDE

- 7 With the oven door open, insert the pointed end of the rotisserie arm into rotisserie catch on the right.

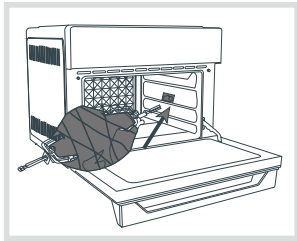

- 8 Next, position the square end of the rotisserie spit in the notch on the left side of the cooking chamber. Ensure the rotisserie spit is securely in place.

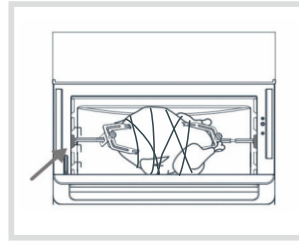

- 9 Close the oven door.

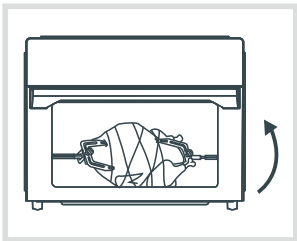

- 10 Select "START/STOP" icon.

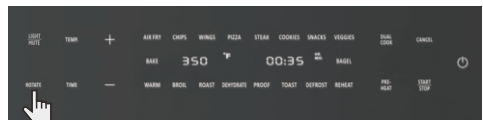

△ CAUTION Ensure the food item is able to rotate freely in the cooking chamber. Do not allow food items to make contact with the heating elements. Insert the cooking tray to catch any grease and/or juices.

PRESET CHART

① Air Fryer Toaster Oven Functions Overview

PRESET	DEFAULT TEMPERATURE	PREHEAT SUGGESTED OR NOT	DEFAULT TIME	DEFAULT FOOD SIZE	ADJUSTABLE TEMP RANGE	TIME RANGE	RECOMMEND ACCESSORIES	POSITION OVERVIEW
AIR FRY (Fried Food)	400°F	YES	10 MINS	600g (room temperature)	200°F-450°F	1 MIN-2H	air fryer basket	
CHIPS (Frozen French Fries)	450°F	YES	18 MINS	500g (Frozen chips)	200°F-450°F	1 MIN-2H	air fryer basket	
WINGS	450°F	YES	18 MINS	700g (room temperature)	200°F-450°F	1 MIN-2H	air fryer basket	
PIZZA	450°F	YES	11 MINS	11 inches (frozen food weight)	200°F-450°F	1 MIN-2H	baking pan/ oven rack	
STEAK	450°F	YES	7 MINS	350g-700g (room temperature)	200°F-450°F	1 MIN-2H	baking pan/ air fryer basket	
COOKIES	360°F	YES	15 MINS	700g-900g (room temperature)	200°F-450°F	1 MIN-2H	baking pan	







PRESET CHART

① Air Fryer Toaster Oven Functions Overview

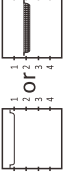
PRESET	DEFAULT TEMPERATURE	PREHEAT SUGGESTED OR NOT	DEFAULT TIME	DEFAULT FOOD SIZE	ADJUSTABLE TEMP RANGE	TIME RANGE	RECOMMEND ACCESSORIES	POSITION OVERVIEW
SNACKS	400°F	YES	18 MINS	800g-850g (Frozen food weight)	200°F-450°F	1 MIN-2H	air fryer basket	
VEGGIES	450°F	YES	15 MINS	900g-1000g	200°F-450°F	1 MIN-2H	baking pan/air fryer basket	
TOAST	450°F	NO	1-7 MINS	6pcs (room temperature)	450°F	/	oven rack	
BAKE	350°F	YES	25 MINS	1000g-1200g (room temperature)	200°F-450°F		1 MIN-2H	baking pan/oven rack
BAGEL	450°F	YES	13 MINS	800g-850g (room temperature dough weight)	200°F-450°F	1 MIN-2H	baking pan/air fryer basket	
BROIL	450°F	YES	12 MINS	600g-650g (room temperature)	200°F-450°F	1 MIN-2H	baking pan/oven rack	

PRESET CHART

① Air Fryer Toaster Oven Functions Overview

PRESET	DEFAULT TEMPERATURE	PREHEAT SUGGESTED OR NOT	DEFAULT TIME	DEFAULT FOOD SIZE	ADJUSTABLE TEMP RANGE	TIME RANGE	RECOMMEND ACCESSORIES	POSITION OVERVIEW
ROAST	400°F	YES	22 MINS	550g-600g (room temperature)	200°F-450°F	1 MIN-2H	baking pan	
DEHYDRATE	140°F	NO	5 H	3-4mm thickness (room temperature)	90°F-180°F	1H - 12H	oven rack/air fryer basket	
PROOF	94°F	NO	45 MINS		90°F-104°F	1 MIN-8H	baking pan	
DEFROST	120°F	NO	20 MINS	800g-900g (frozen food weight)	90°F-180°F	1 MIN-2H	baking pan	
REHEAT	200°F	NO	5 MINS		200°F-450°F	1 MIN-2H	oven rack	
WARM	120°F	NO	4 H		90°F-250°F	1 MIN-8H	baking pan	
ROTATE	400°F	YES	30 MINS	1000g-1500g (room temperature meat)	200°F-450°F	1 MIN-2H	rotisserie fork	

Note : Time and temperature need to be adjusted if food size is different.

DUAL COOK FUNCTIONS QUICK REFERENCE CHART

FUNCTION 1	FUNCTION 2	PREHEAT	Suggested Amount of Food	Suggested Accessory	Suggested Rack Position
AIR FRY	WARM	Yes	Base on the food you select	Air Fryer Basket	2
BAKE	BROIL	Yes	Base on the food you select	Baking Pan or Oven Rack	3
AIR FRY	WARM	Yes	Base on the food you select	Baking Pan or Rotisserie Fork	4 or Rotisserie fork position
ROAST	AIR FRY	Yes	Base on the food you select	Baking Pan or Rotisserie Fork	4 or Rotisserie fork position
AIR FRY	BROIL	Yes	Base on the food you select	Air Fryer Basket or Oven Rack	2 or 3

It is a normal occurrence that some moisture may occur on the oven door during the cooking process. We would like to recommend you to preheat the Air Fryer Toaster Oven before cooking.

REPLACING THE LIGHT

ATTENTION: Be sure to unplug the Air Fryer Toaster Oven and allow it to cool completely before replacing the oven light.

SPECIFICATION: 25W halogen bulb

1. Rotate the lampshade counterclockwise to remove it.

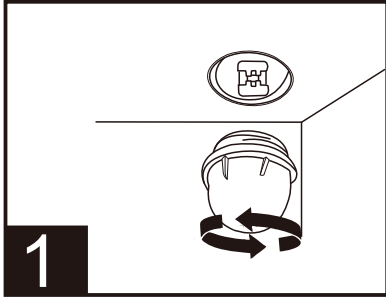

2. Remove the used bulb by pulling it directly.

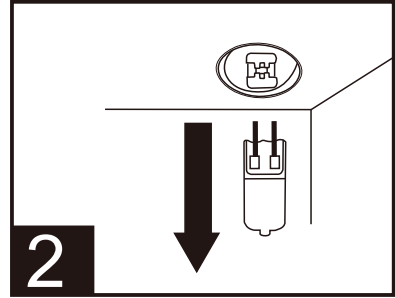

3. Insert the new bulb

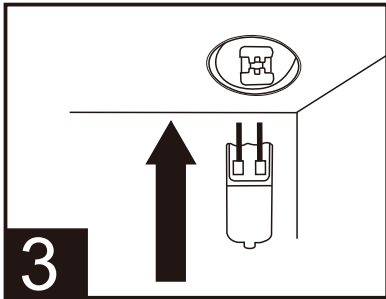

4. Twist the lampshade clockwise to tighten it.

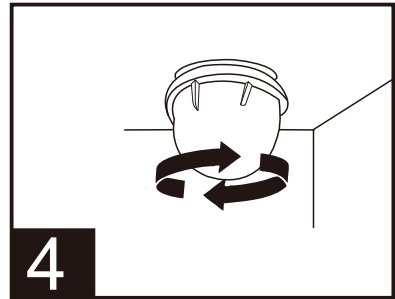

CARE, CLEANING & STORAGE

Before cleaning, remove the power plug from the power outlet. Allow the oven and all accessories to cool completely before disassembling and cleaning.

Cleaning the glass door

CAUTION: Outer glass and inner glass of the oven door can be cleaned directly by using a soft, damp sponge or soft plastic scouring pad with glass cleaner or mild detergent. If there is a large amount of food residue or grease accumulated between two glasses, inner door glass can be disassembled and cleaned following below instruction. Please be sure to install it back after cleaning. It is not recommended to disassemble the glass frequently.

1. Loosen the screws on the glass door, suck up the glass with a Suction Cup, and then take it out with hand carefully. Attention: Do not take out the glass with Suction Cup, otherwise the glass will fall off.

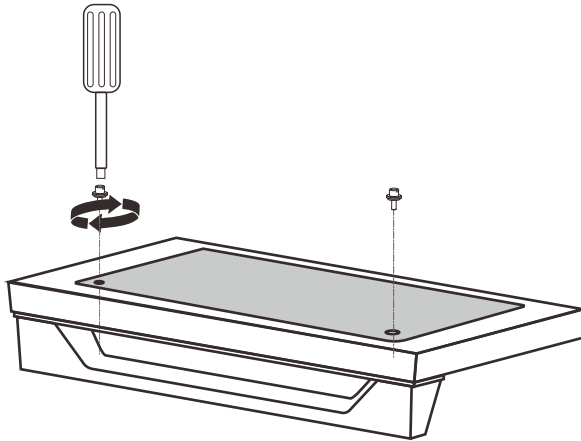

2. To clean the door, use a glass cleaner or mild detergent and a soft damp sponge or soft plastic scouring pad. Do not use an abrasive cleaner or metal scouring pad as these will scratch the glass.

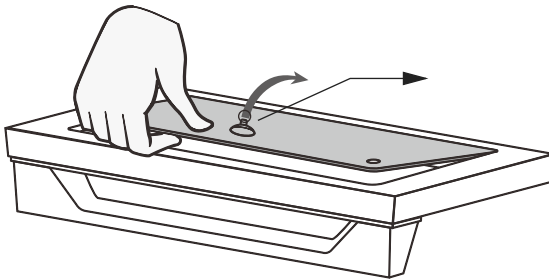

3. After cleaning and drying the glass, put the glass back and tighten the screws.

CARE, CLEANING & STORAGE

Before cleaning, remove the power plug from the power outlet. Allow the oven and all accessories to cool completely before disassembling and cleaning.

Cleaning outer body

- Wipe the outer body with a soft, damp sponge. A non-abrasive liquid cleanser or mild spray solution may be used to avoid build-up of stains. Apply cleanser to the sponge, not the oven's surface, before cleaning.
- Wipe LED screen with a soft, damp cloth. Apply cleanser to cloth, do not apply cleanser directly on to the LED. Cleaning LED screen surface with a dry cloth and/or abrasive cleaners may produce scratches.



WARNING: To prevent electrocution, do not immerse the appliance or power cord into water or any other liquid.

Cleaning the interior

- To clean any spattering that may occur while cooking, wipe the walls with a soft, damp sponge. A non-abrasive liquid cleanser or mild spray solution may be used to avoid build-up of stains. Apply the cleanser to the sponge, not the interior, before cleaning.



WARNING: Use extreme caution when cleaning the heating elements. Allow the oven to cool completely, and then gently rub a soft, damp sponge or cloth along the length of the heating element. Do not use any type of cleanser or cleaning agent. Let all surfaces dry thoroughly prior to inserting the power plug into a power outlet and turning the oven on.

Cleaning the crumb tray

- After each use, slide out the crumb tray and discard crumbs. Wipe the tray with a soft, damp sponge. A non-abrasive liquid cleanser or mild spray solution may be used to avoid build-up of stains. Apply the cleanser to the sponge, not the tray, before cleaning. Dry thoroughly.
- To remove the baked-on grease, soak the tray in warm soapy water then wash with a soft sponge or soft plastic scouring pad. Rinse and dry thoroughly.
- Always ensure to re-insert the crumb tray into the oven after cleaning and prior to inserting the power plug into a power outlet and turning the oven on.

Cleaning the Oven rack, baking pan, fry basket, rotisserie and remove handle.

- Wash all accessories in warm soapy water with a soft sponge or soft plastic scouring pad. Rinse and dry thoroughly. Do not use abrasive cleansers, metal scouring pads or metal utensils to clean any of the accessories as they may damage the surfaces.
- To extend the life of your accessories, cleaning them in the dishwasher is not recommended.

Storage

- Ensure the oven and all accessories are clean and dry.
- Ensure the door is closed.
- Store the appliance in an upright position, standing level and on its supporting legs. Do not store appliance when wet or hot. Do not store in a wet or hot environment.

TROUBLESHOOTING

Possible Problem	Possible Cause	Solution
The oven does NOT work	The appliance is not plugged in	Make sure the oven is plugged in.
	You have not turned on the oven	Touch the POWER ON/OFF icon to power on
	The door is not closed properly	Make sure the door is closed well.
Steam is coming out from the top of the oven door	You are cooking high moisture content foods	This is normal. The door is vented to release steam created from high-moisture content foods such as frozen breads.
White smoke is coming out of the oven	This is the first time using the oven	This is normal upon first use. We suggest setting the oven to the highest temperature and letting it run empty from 18-20 minutes.
	You're cooking greasy food	This is normal when cooking greasy foods. This will not affect the cooking process.
	The baking pan, crumb tray, or heaters still contain grease or oil residue from previous use	Ensure each component is properly cleaned after each use.
Dark smoke is coming out of the oven	Food is burning	Immediately turn off the oven, be careful when you take out the food.

If the above solutions cannot solve your problem, please feel free to contact us directly:

www.beelicious.shop
support@beelicious.shop
facebook.com/Beelicious.shop

Possible Problem	Possible Cause	Solution
The ingredients cooked with the oven are not done	Too much food in the oven at once	Reduce the amount of food in the oven when cooking.
	Setting temperature too low or time too short	Set the temperature higher or time longer.
	Choose the incorrect function	Make sure you cook with the proper function.
Foods are cooked unevenly	Ingredients are stacked or close to each other during cooking	Make sure food and ingredients are spread out evenly.
	Baking pan, Air Fry basket or oven rack position is not adjusted	Adjust oven inserts into the proper position. Take caution as these components may be hot.
Foods are not crispy after Air Frying	Ingredients with high moisture	Spraying or brushing a small amount of oil on food evenly can increase crispiness.
Display shows Error Code "E1"	There is a short circuit in the temperature monitor	Remove the power cord from the power outlet. Contact Customer Support.
Display shows Error Code "E2"	The temperature monitor or heaters is inoperative	Remove the power cord from the power outlet, reconnect and operate again. If it cannot be solved, then Contact Customer Support.

If the above solutions cannot solve your problem, please feel free to contact us directly:

www.beelicious.shop
support@beelicious.shop
facebook.com/Beelicious.shop

Through the following channels,
you can quickly contact us.

✉ www.beelicious.shop

🏠 support@beelicious.shop

📘 facebook.com/Beelicious.shop



◀ Scan code to activate extended warranty online.

Scan this QR code to get the operation video. ▶

