

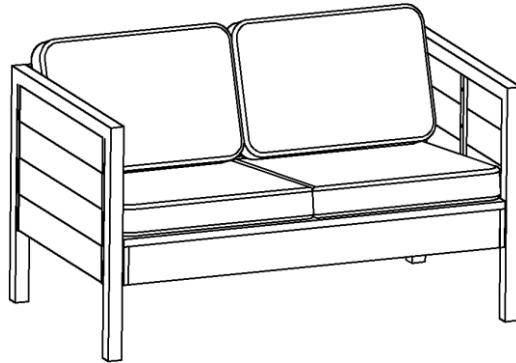



Assembly Instructions

Caution : You must read this before you proceed

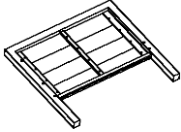
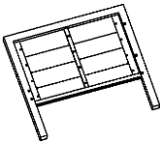
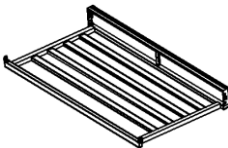
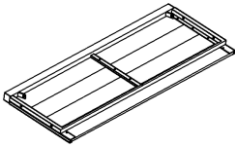
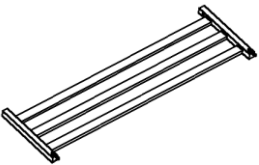

Loveseat

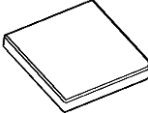

Part List

Label	Picture	Description	QTY
A		Right Armrest	1
B		Left Armrest	1
F		Seat	1
G		Outer Backrest	1
H		Inside Backrest	1
M		Left Seat Cushion	1
N		Right Seat Cushion	1
L		Back Cushion	2

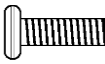
Hardware

Label	Picture	Description	QTY
①		Allen Key	1
②		Bolt (M6*20mm)	9
③		Bolt (M6*40mm)	5
④		Washer	13

Assembly Preparation

Before Beginning Assembly :

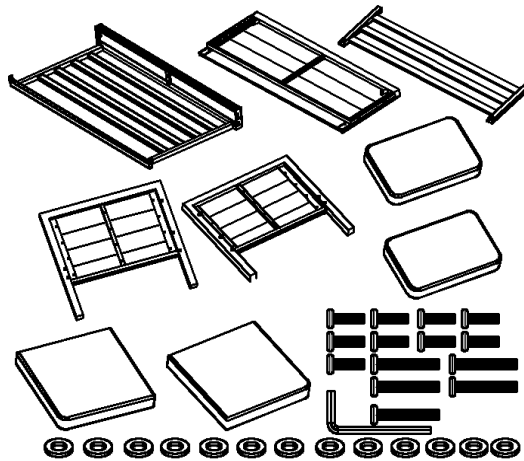

- Read instructions, cover to cover-



- Have 2 adults on hand for assembly-



- Do not assemble on flooring or carpet-



- Assemble on a clean non-marring surface (packing foam)-



- Save all packaging until finished-

Assembly Steps

Overview

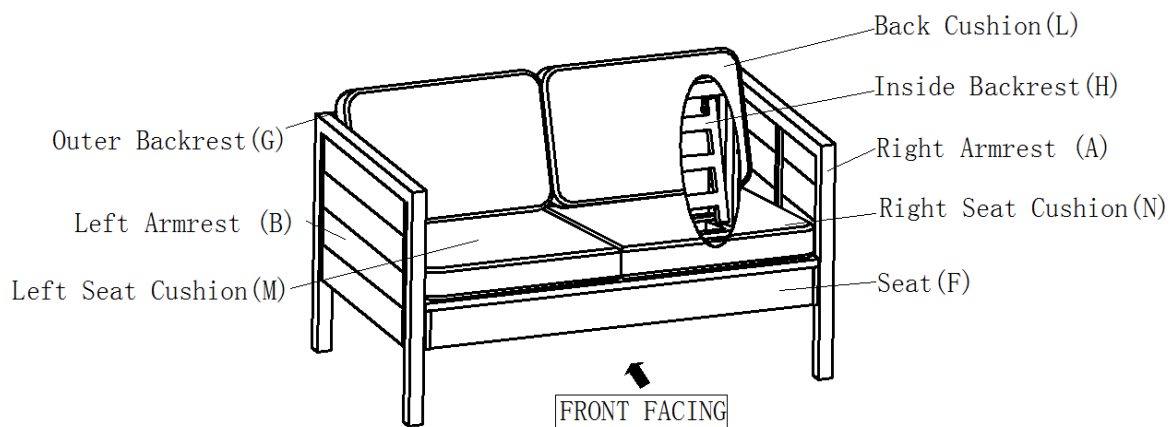

This Loveseat has multiple parts and may require up to 30 minutes to assemble.

To give you an overview of the Loveseat parts, the above picture is to help you put the various parts into perspective. Please read through the instructions below to familiarise yourself with the parts and steps before assembly.

Step 1

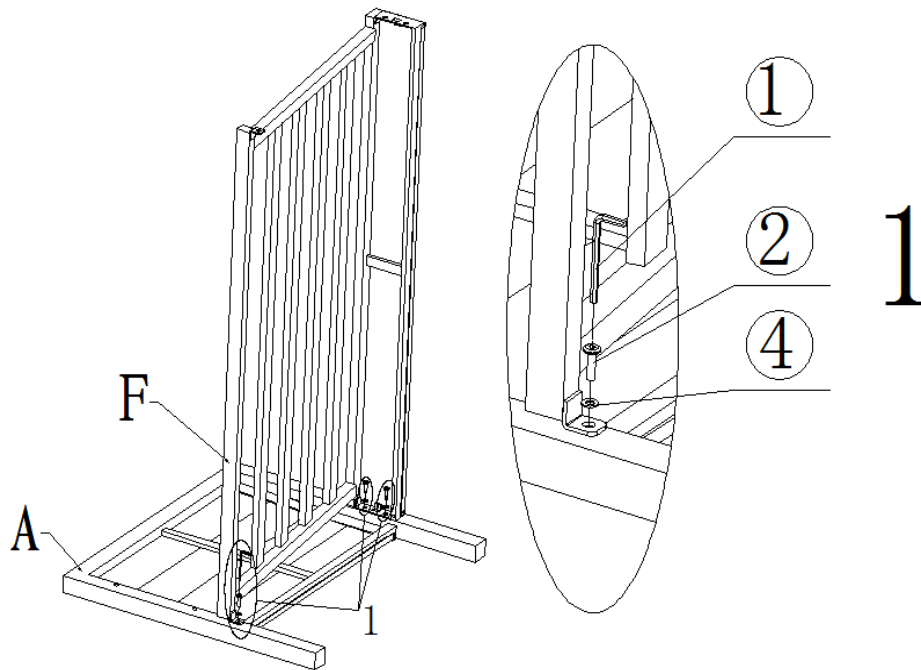

Open the carton and place all the parts onto a clean, non-marring surface.
Place the Right Armrest(A) with its inside facing skywards.
Align Seat(F) against the Right Armrest(A) as pictured.
Attach Seat(F) and Right Armrest(A) using Bolts(②) and Washers(④) with Allen Key(①).
Do not fully tighten the Bolts.

Step 2

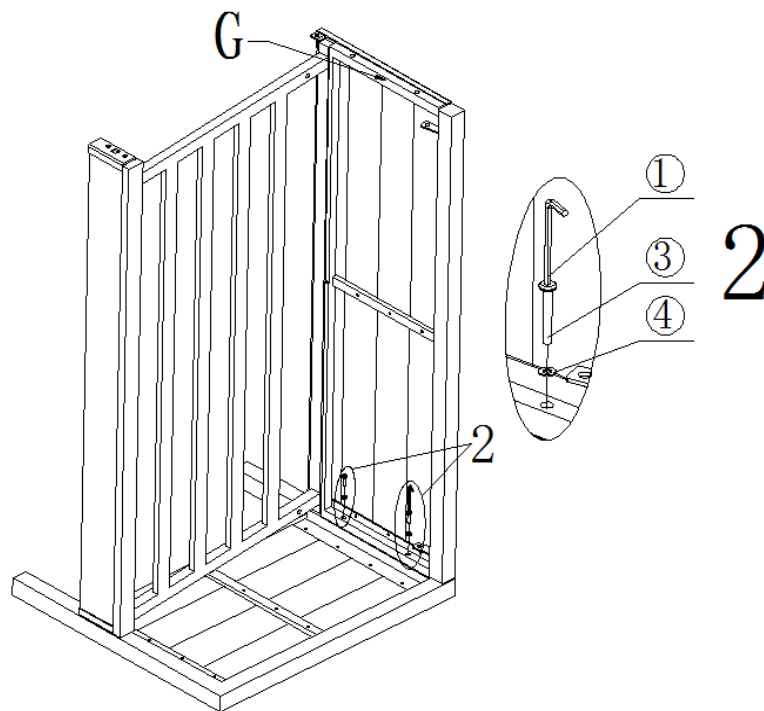

Place the Outer Backrest(G) between the Right Armrest(A) and Seat(F).
Attach Outer Backrest(G) to Right Armrest(A) using Bolts(③) and Washers(④) with Allen Key(①).
Do not fully tighten the Bolts.

Step 3

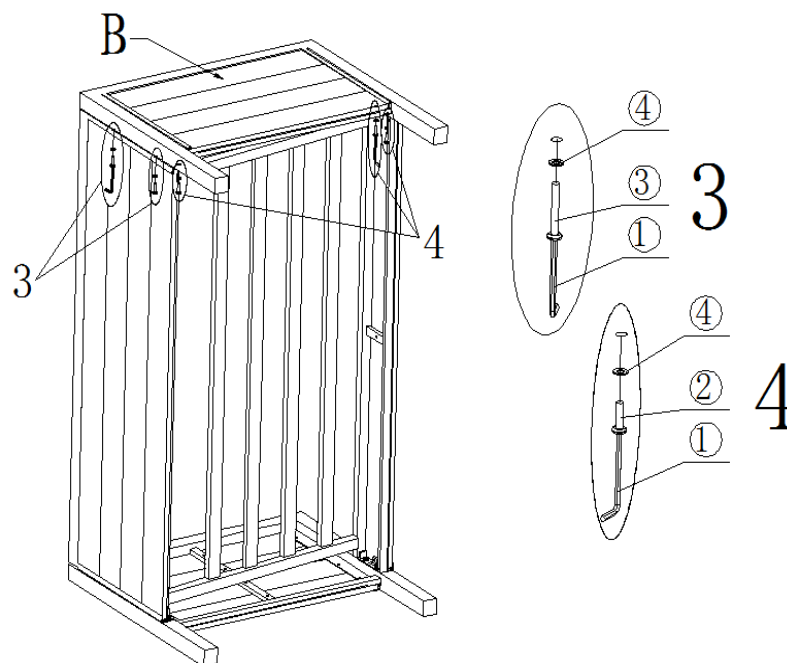

Place the Left Armrest(B) against the Outer Backrest(G) and Seat(F).
Attach the Left Armrest(B) to Seat(F) using Bolts(②) and Washers(④) with Allen Key(①).
Attach Left Armrest(B) to Outer Backrest(G) using Bolts(③) and Washers(④) with Allen Key(①).

Do not fully tighten the Bolts.

Step 4

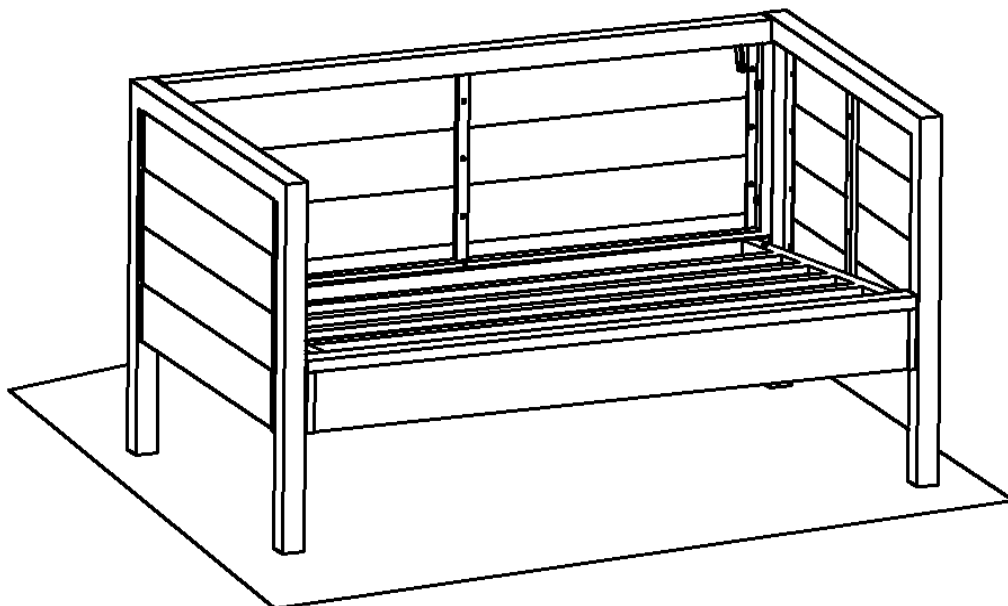

Stand the Sofa right side up.

Tighten all Bolts completely, in a sequential manner.

Then adjust the Levelers at the bottom of the Legs to ensure good stability.

Step 5

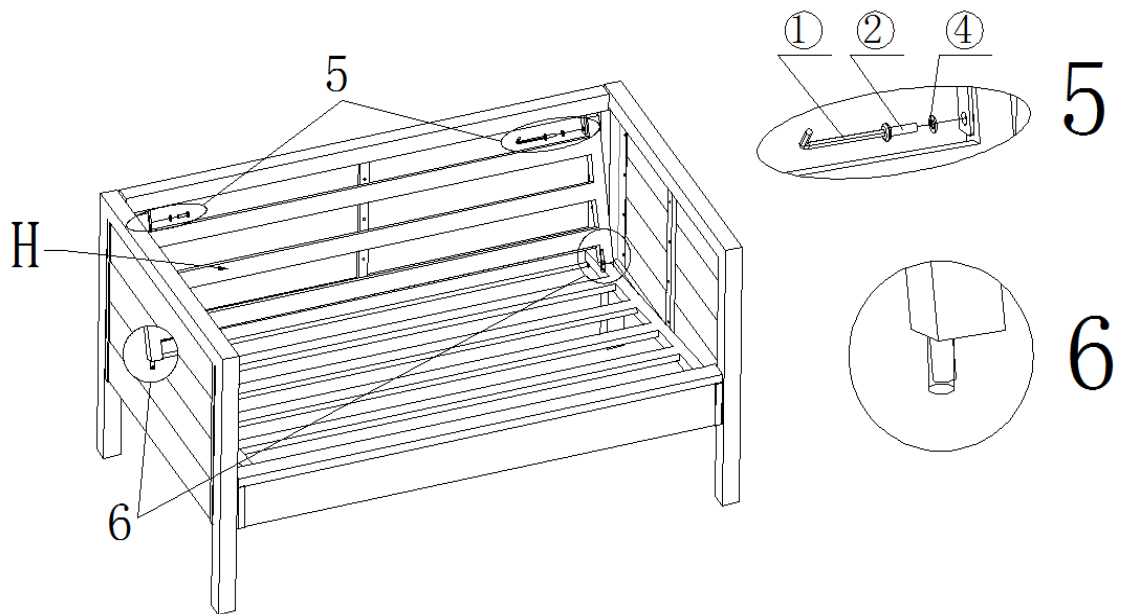

Place the Inside Backrest(H) against the Seat(F).

Attach the Inside Backrest(H) to Outer Backrest(G) using Bolts(②) and Washers(④) with Allen Key(①).

Tighten the Bolts fully in a sequential manner.

Step 6

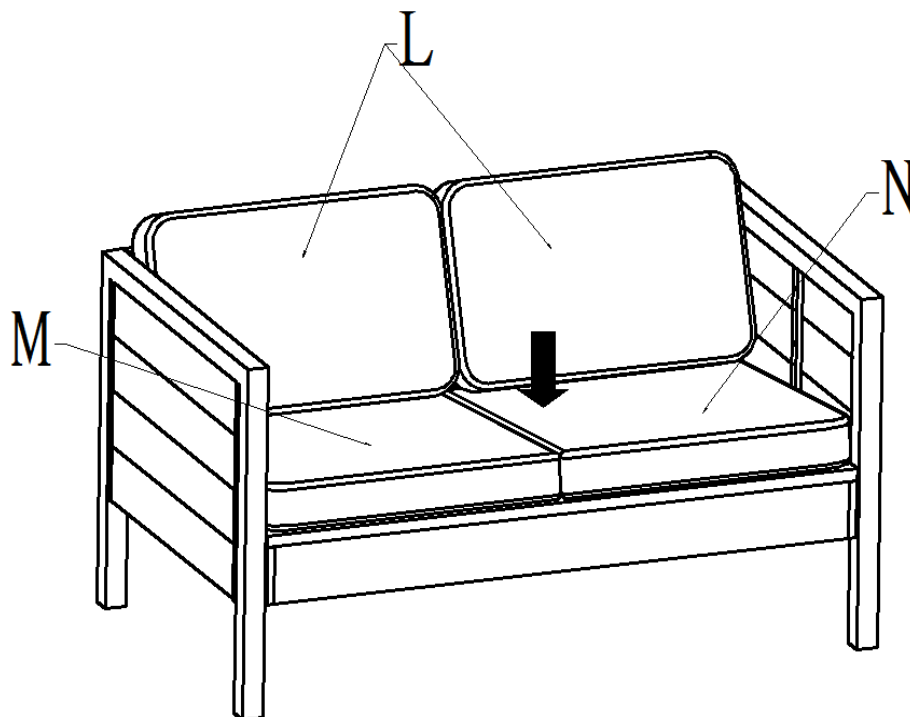































Place the Left Seat Cushion(M), Right Seat Cushion(N) and Back Cushions(L) onto the Loveseat.

Your Loveseat is ready for use.

This Loveseat can only be used on a flat, level surface.

Care & Maintenance

-    Do not put hot items directly on furniture surface
 -    Do not clean furniture with harsh cleansers or polish.
 -    To obtain the longest lifespan of your outdoor products, minimizing exposure to direct sunlight is recommended.
 -    Children should not climb or jump on the furniture.
 -    Do not write on furniture without a padded barrier to protect the surface.
 -    To obtain the longest lifespan of your outdoor products, avoid extended and lengthy exposure to rain, snow, and direct sunshine. Whenever possible cover the product and /or place under patio or awnings.
 -    Not for commercial use. For residential use only .
 -    Stains may be removed with mild soap solution and damp cloth.
 -    Keep away from sources of ignition.
-
-    Dust and pick-up spills using a clean, non-colored, lint-free cloth .



Assembly Instructions

Caution: You must read this before you proceed

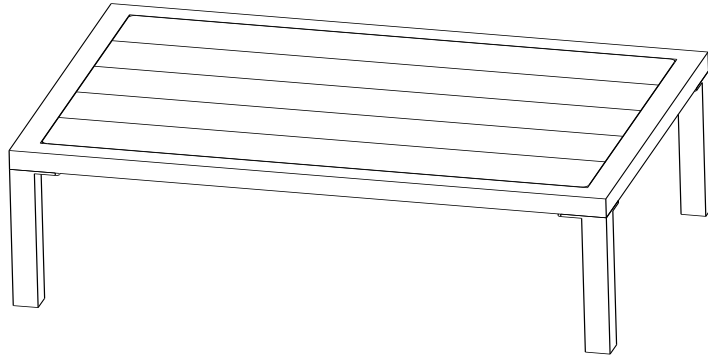

Table

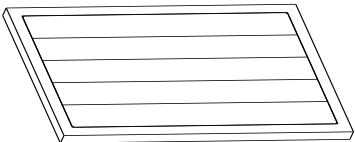

Part List

Label	Picture	Description	QTY
I		Table Top	1
J		Leg	4

Hardware

Label	Picture	Description	QTY
①		Allen Key	1
②		Bolt (M6*20mm)	13
③		Washer	13

Assembly Preparation

Before Beginning Assembly:

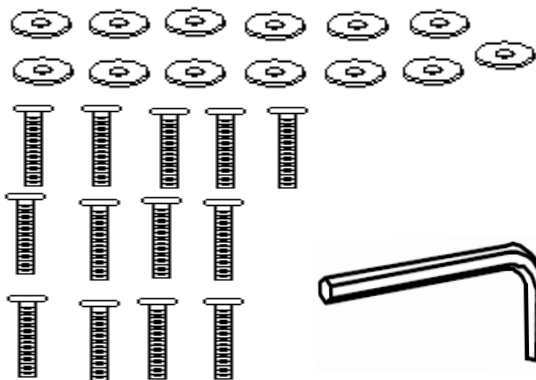
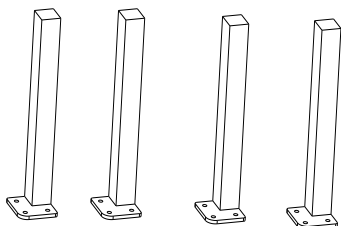

- Read instructions, cover to cover-



- Have 2 adults on hand for assembly-



- Do not assemble on flooring or carpet-



- Assemble on a clean non-marring surface (packing foam)-



- Save all packaging until finished-

Assembly Steps

Overview

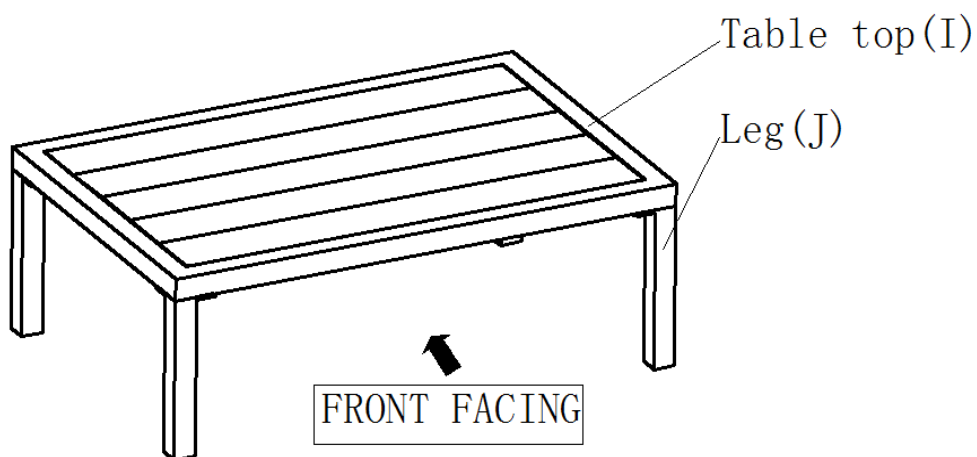

This Table has multiple parts and may require up to 30 minutes to assemble. To give you an overview of the Table parts, the above picture is to help you put the various parts into perspective. Please read through the instructions below to familiarise yourself with the parts and steps before assembly.

Step 1

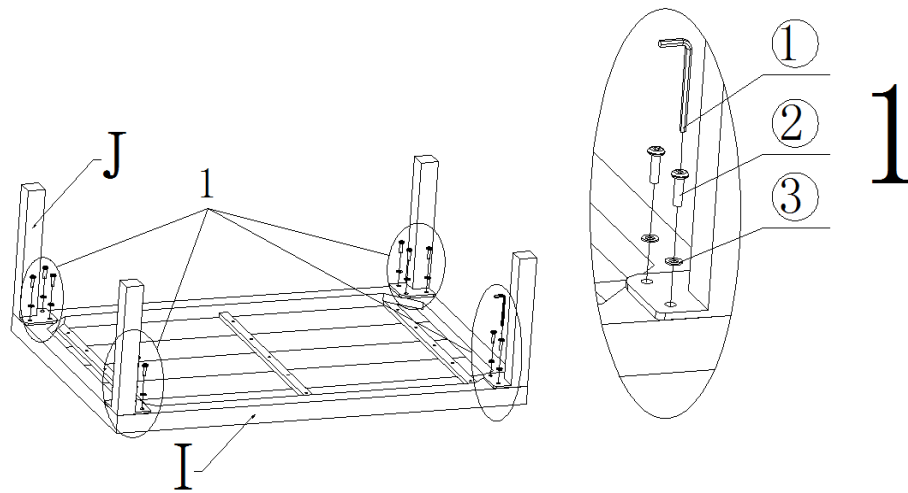

Open the carton and place all the parts onto a clean, non-marring surface.

Place the Table Top(I) facedown on as pictured.

Attach Leg(J) to Table Top(I) using Bolts(2) and Washers(3) with Allen Key(1). **Repeat the same process with the remaining three Legs(J).**

Do not fully tighten the Bolts.

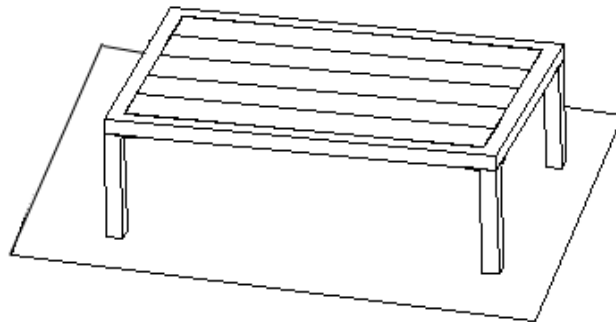

Stand the Table right way up. Place the Table on a **LEVEL SURFACE** to check for wobbles.

If it wobbles, lift the Table some 20cm to 30cm high from the ground.

Keep your feet and toes well away from the drop zone.

Drop the table freely and vertically with all four legs, hitting the ground, at the same time.

This Drop Test will help to ensure that all Bolts and gaps reach full alignment status.

Test again for evenness on a **LEVEL SURFACE**.

If no wobbles are found, slowly and carefully, turn the Table facedown.

Then, proceed to tighten all Bolts in a sequential manner.

When tightening the Bolts, tighten sequentially.

DO NOT tighten any Bolt fully and then move on towards the next one.

If there are still wobbles, loosen the Bolts and execute the same drop test.



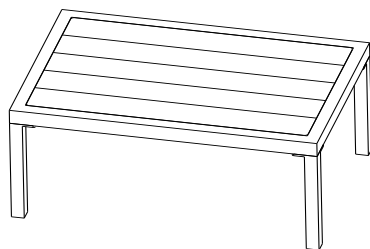

















Step 3



Your Table is ready for use.

This Table can only be used on a flat, level surface.

Care & Maintenance

-   ● Do not put hot items directly on furniture surface
 -   ● Do not clean furniture with harsh cleansers or polish.
 -   ● To obtain the longest lifespan of your outdoor products, minimizing exposure to direct sunlight is recommended.
 -   ● Children should not climb or jump on the furniture.
 -   ● Do not write on furniture without a padded barrier to protect the surface.
 -   ● To obtain the longest lifespan of your outdoor products, avoid extended and lengthy exposure to rain, snow, and direct sunshine. Whenever possible cover the product and /or place under patio or awnings.
 -   ● Not for commercial use. For residential use only .
 -   ● Stains may be removed with mild soap solution and damp cloth.
 -   ● Keep away from sources of ignition.
-
-   ● Dust and pick-up spills using a clean, non-colored, lint-free cloth .