

# ASSEMBLY INSTRUCTIONS



*Fine Furniture for every stage of life*

**(B1&B2)**  
**Eastern King Bed**

REVISION 0 : 04/13/2016  
REVISION 1 : 08/15/2019

# ASSEMBLY INSTRUCTIONS

## ASSEMBLY TIPS:

1. Remove hardware from box and sort by size.
2. Please check to see that all hardware and parts are present prior to start of assembly.
3. Please follow attached instructions in the same sequence as numbered to assure fast & easy assembly.



### WARNING!

1. Don't attempt to repair or modify parts that are broken or defective. Please contact the store immediately.
2. This product is for home use only and not intended for commercial establishments.



ASSEMBLY TIME

14 MINUTES

## PARTS IDENTIFICATION

### B1 ( BOX 1)

A HEADBOARD PANEL

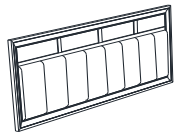

1PC

B FOOTBOARD

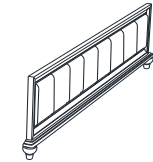

1PC

C RIGHT HEADBOARD LEG

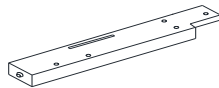

1PC

D LEFT HEADBOARD LEG

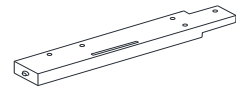

1PC

E BED SLAT

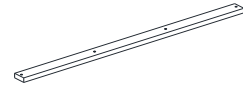

4PCS

F BED SLAT SUPPORT WITH LEVELER

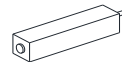

8PCS

### B2 ( BOX 2)

G BED RAIL

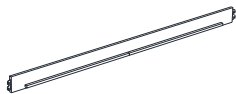

2PCS

HB HEADBOARD COMPLETE

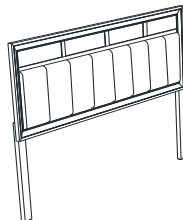

1PC

B FOOTBOARD

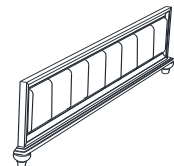

1PC

# ASSEMBLY INSTRUCTIONS

## ASSEMBLY TIPS:

1. Remove hardware from box and sort by size.
2. Please check to see that all hardware and parts are present prior to start of assembly.
3. Please follow attached instructions in the same sequence as numbered to assure fast & easy assembly.







## WARNING!

1. Don't attempt to repair or modify parts that are broken or defective. Please contact the store immediately.
2. This product is for home use only and not intended for commercial establishments.

## HARDWARE IDENTIFICATION

### Z-B1 (BOX 1) - HARDWARE PACK IS LOCATED IN (B1)

1	<b>BOLT</b> (M6 x 30mm - BLK)		6PCS
2	<b>LOCK WASHER</b> (1/4" - BLK)		6PCS
3	<b>FLAT WASHER</b> (1/4" ID x 13mm - BLK)		6PCS
4	<b>ALLEN WRENCH</b> (M4 x 60mm - BLK)		1PC
5	<b>FLAT HEAD SCREW</b> (M4 x 32mm - RBW)		8PCS

## NOTE:

Phillips head screw driver is required in the assembly process; however, manufacturer does not provide this item.

# ASSEMBLY INSTRUCTIONS

## STEP 1

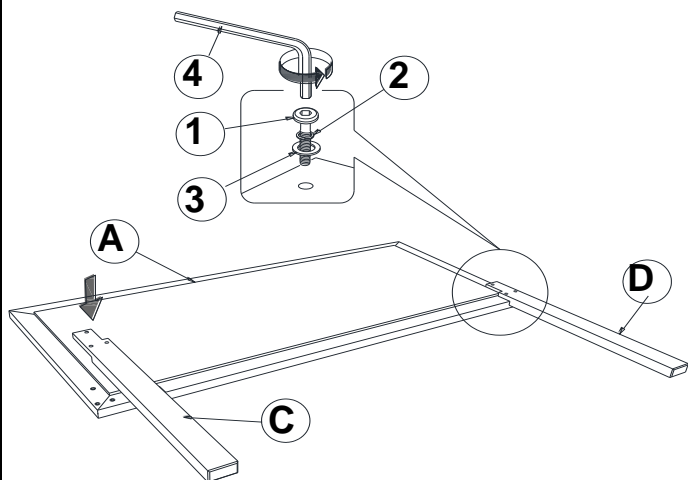

**\*\*BACK VIEW\*\***

Note : Please take note of the marking sticker (L&R) on the leg.

## STEP 2

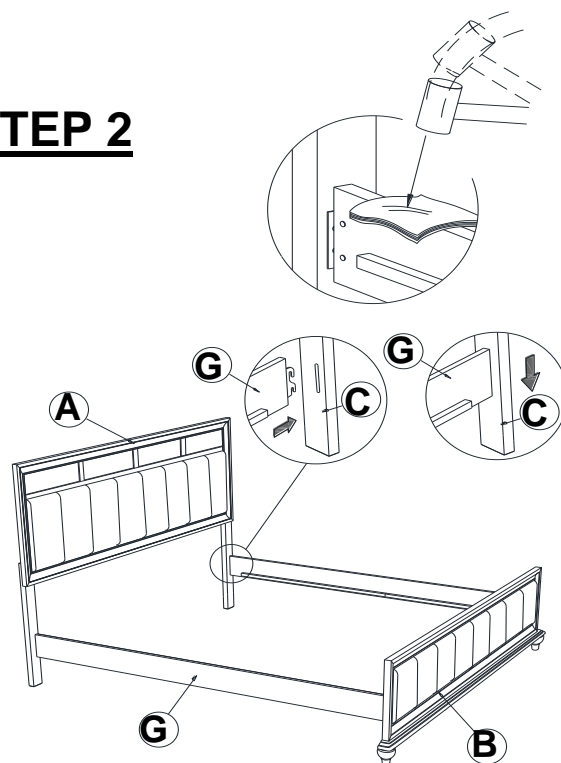

**Note :** Make sure the protective cloth is sufficient enough to protect bed rail (G) before hammering.

## STEP 3

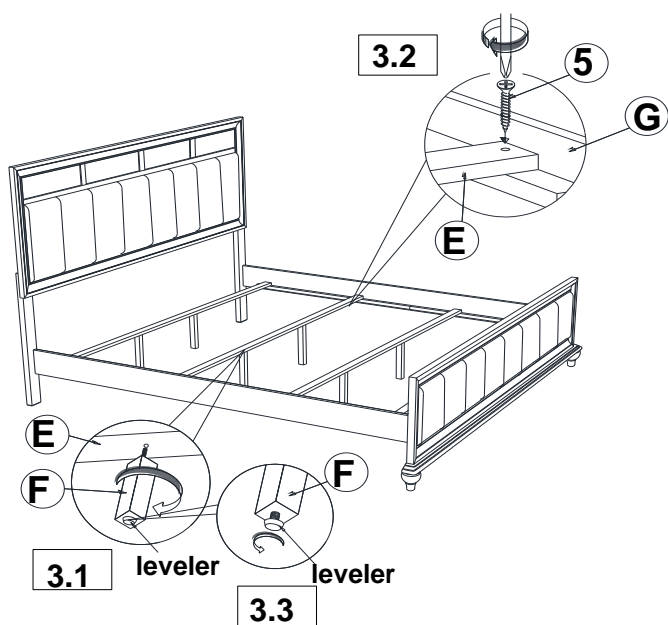

## STEP 4 COMPLETE

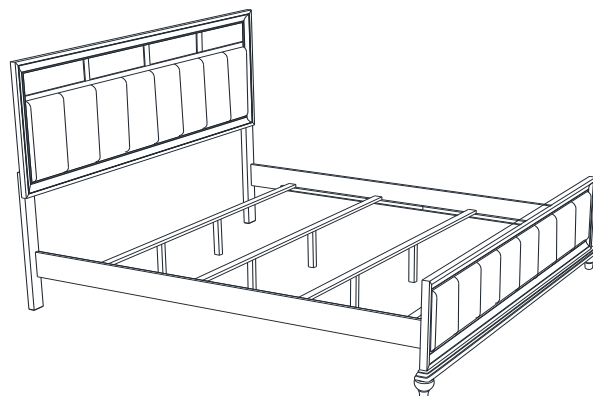

Inner Size: 76.75"W X 81.00"D

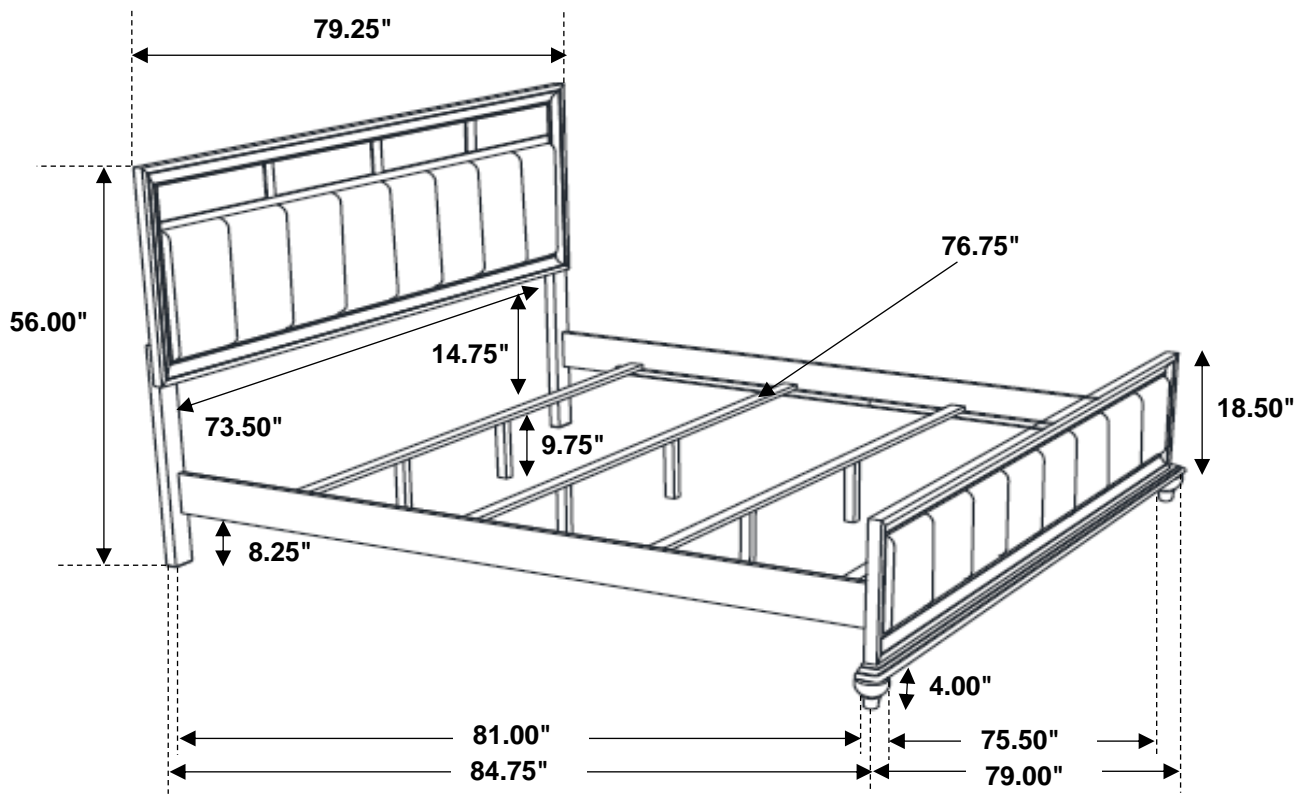

Note: Dimension tolerance  $\pm 5\%$