

- EN** - Please read this instruction manual carefully before attempting to install.
- DE** - Bitte lesen Sie diese Bedienungsanleitung vor der Montage gründlich durch.
- ES** - Por favor lea con atención el manual de instrucciones antes de llevar a cabo el ensamble.
- FR** - Lisez attentivement cette notice avant de commencer le montage.
- IT** - Si prega di consultare il libretto delle istruzioni prima del montaggio.

IMPORTANT/WICHTIG/ATENCIÓN

IMPORTANT/IMPORTANTE



EN - We recommend **2** or more people to install.
DE - Wir empfehlen, dass die Montage von **2** oder mehreren Personen durchgeführt werden sollte.
ES - Recomendamos realizar el ensamble con **2** o más personas.
FR - Il est recommandé d'effectuer le montage à **2** personne(s) ou plus.
IT - È necessaria la presenza di **2** o più persone per il montaggio di questo prodotto.



EN - The expected assembly time is **1 h**.
DE - Die Montagezeit beträgt durchschnittlich **1 h**.
ES - El tiempo aproximado de ensamble es de **1 h**.
FR - Le temps nécessaire est estimé à **1 h**.
IT - Il tempo previsto per il corretto assemblaggio è di **1 h**.



EN - Not intended for use by children.
DE - Nicht geeignet für Kinder.
ES - Producto no apto para niños.
FR - Produit non destiné à être utilisé par des enfants.
IT - Questo prodotto non è destinato all'uso da parte dei bambini.



EN - Keep away from fire or other heat sources.
DE - Bitte von Feuer und Hitzequellen fernhalten.
ES - Manténgase alejado de las llamas y otras fuentes de calor.
FR - Tenir à distance des flammes et autres sources de chaleur.
IT - Tenere lontano dal fuoco o da altre fonti di calore.



EN - We recommend wearing protective gloves.
DE - Wir empfehlen das Tragen von Schutzhandschuhen.
ES - Recomendamos el uso de guantes de seguridad.
FR - Il est recommandé de porter des gants de protection.
IT - Per il processo di assemblaggio, consigliamo fortemente l'utilizzo di guanti protettivi.

EN - Please follow the instruction manuals and use a pad to avoid damage during assembly.







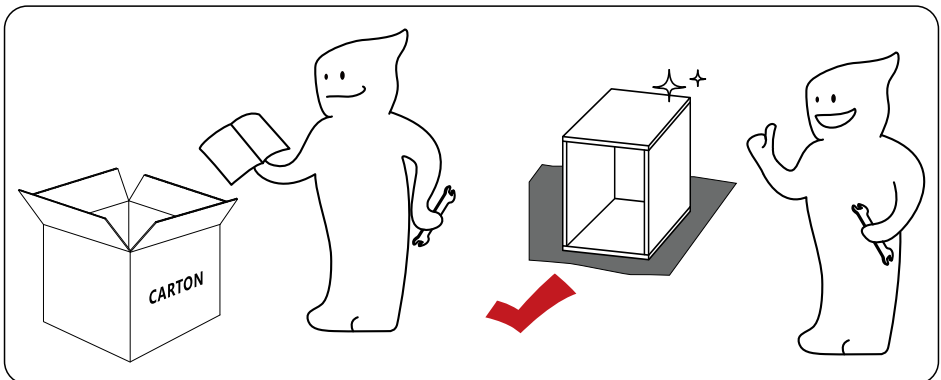
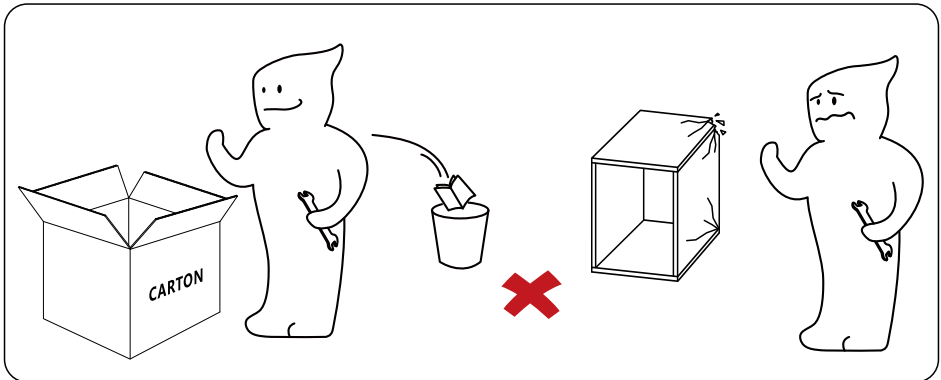

DE - Bitte folgen Sie der Anleitung und verwenden Sie eine Unterlage, um Beschädigungen bei der Montage zu vermeiden.





ES - Por favor, siga las instrucciones del manual y utilice una cubierta o lona para proteger el producto y el suelo durante la instalación.

FR - Suivez les instructions de la notice et utilisez une couverture ou une bâche pour protéger le produit et les sols pendant le montage.

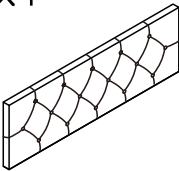
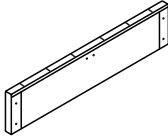
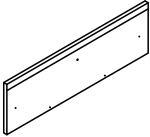
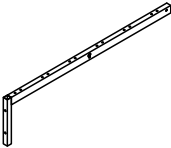
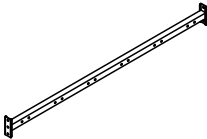
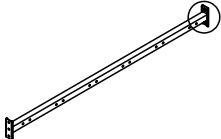
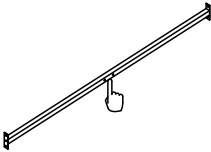
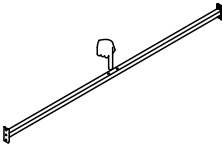
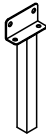
IT - Si prega di consultare il manuale illustrativo durante il montaggio e di utilizzare un cuscinetto per evitare possibili danni.

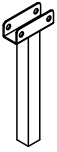
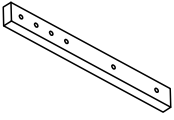

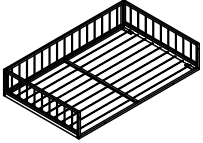

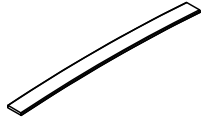
<p>① × 12</p>  <p>20mm</p>	<p>② × 16</p>  <p>40mm</p>	<p>③ × 2</p>  <p>50mm</p>
<p>④ × 4</p> 	<p>⑤ × 4</p> 	<p>⑥ × 32</p> 
<p>⑦ × 8</p> 	<p>⑧ × 16</p>  <p>25mm</p>	<p>⑨ × 1</p> 
<p>Ⓐ × 1</p> 	<p>Ⓑ × 1</p> 	<p>Ⓒ × 4</p> 
<p>Ⓓ × 4</p> 	<p>Ⓔ × 1</p> 	<p>Ⓕ × 1</p> 
<p>Ⓕ × 1</p> 	<p>Ⓖ × 1</p> 	<p>Ⓗ × 2</p> 

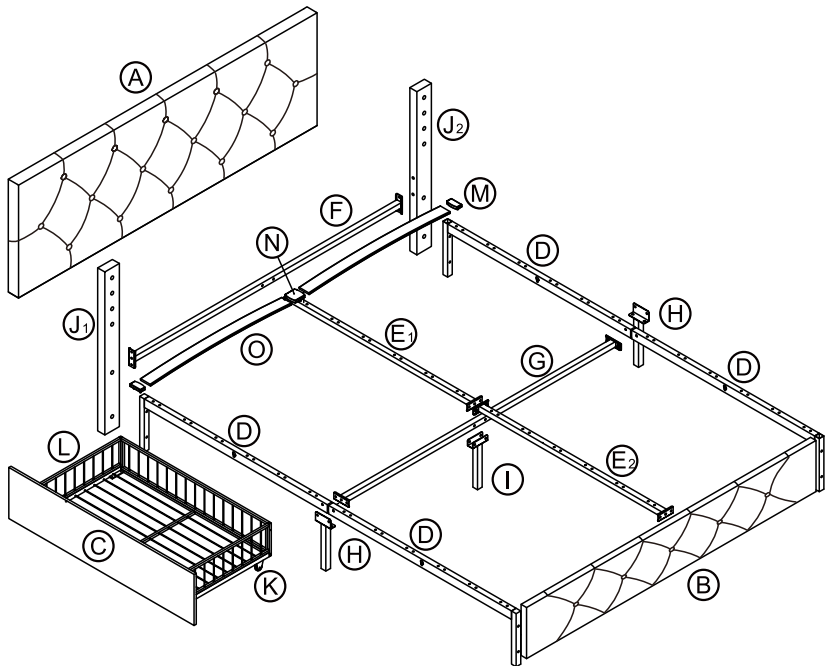
<p>Ⓛ × 1</p> 	<p>Ⓝ₁ × 1 L</p> 	<p>Ⓝ₂ × 1 R</p> 
<p>Ⓚ × 16</p> 	<p>Ⓛ × 4</p> 	<p>Ⓜ × 24</p> 
<p>Ⓝ × 12</p> 	<p>Ⓞ × 24</p> 	



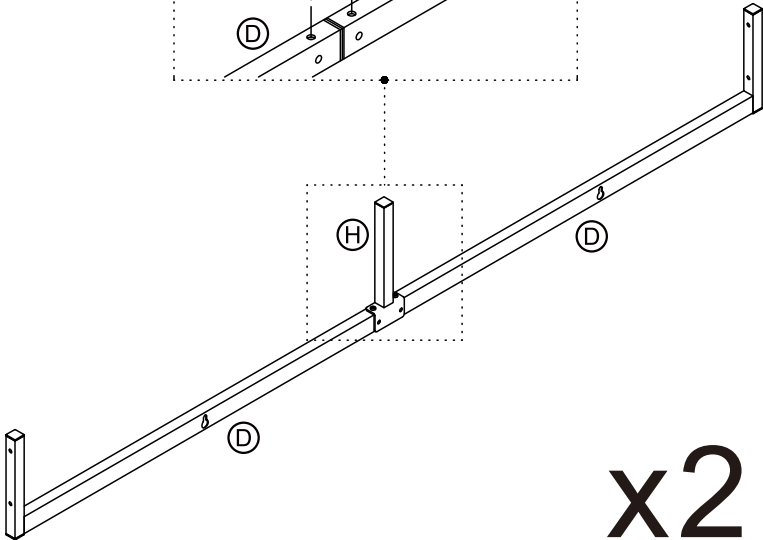
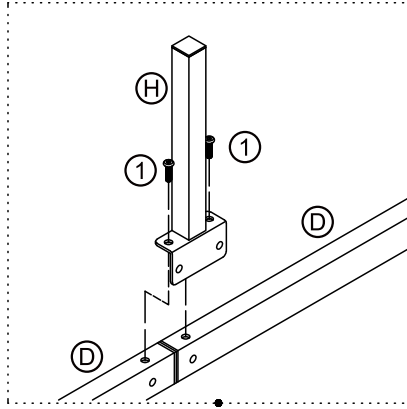

1

①		x2
Ⓓ		x2
Ⓕ		x1







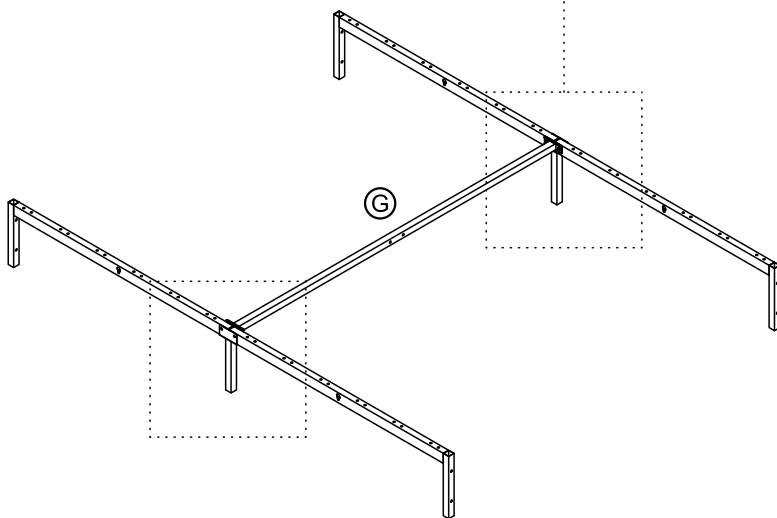
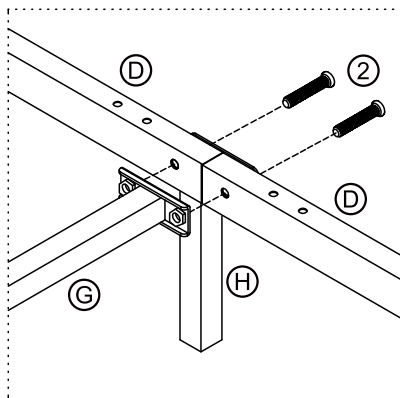

2

②		x4
Ⓒ		x1



3

①		X4
②		X4
Ⓐ		X1
Ⓕ		X1
Ⓐ ₁		X1
Ⓐ ₂		X1

EN - During the assembly, please first half-tighten all the screws into the holes. After all the screws are set, fully tighten them.

DE - Bitte alle Schrauben leicht von Hand eindrehen, erst nachdem alle eingedreht sind, die Schrauben dann vollständig mit dem Inbusschlüssel festziehen.

ES - Durante el montaje, apriete todos los tornillos sólo hasta la mitad. Después de insertar todos los tornillos, apriételes completamente.

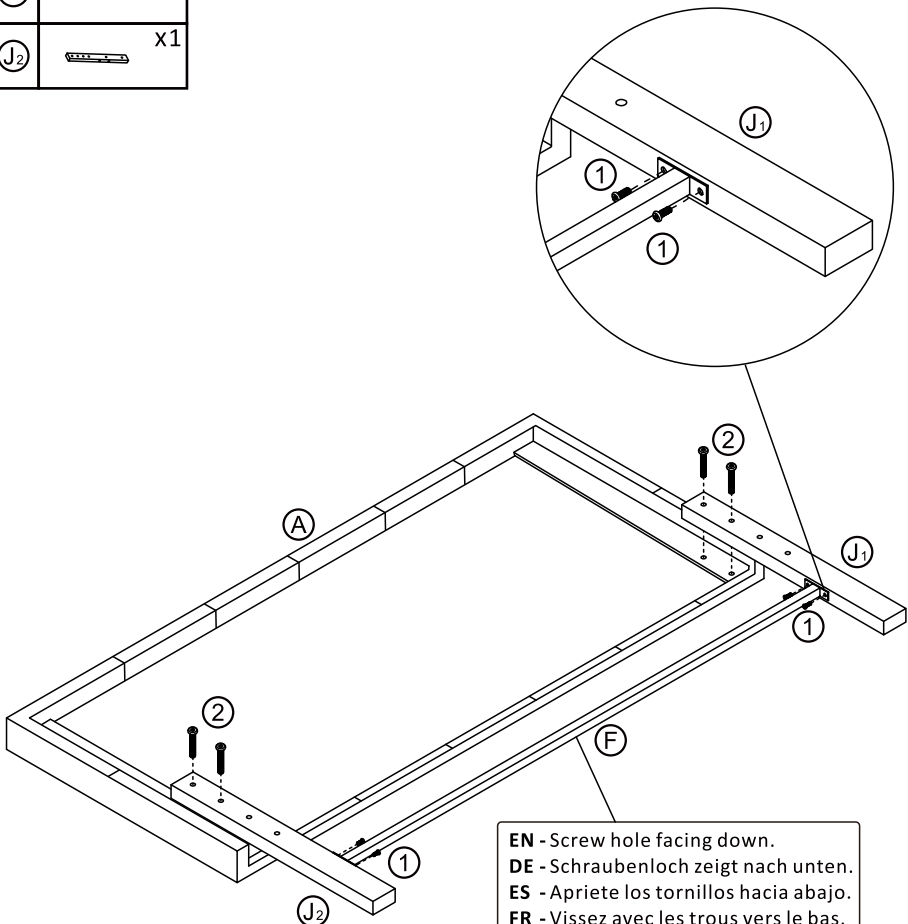

FR - Pendant le montage, il est recommandé de ne serrer les vis qu'à demi. Ne vissez à fond qu'une fois toutes les vis insérées.

IT - Durante il montaggio, si prega di stringere tutte le viti solo a metà. Solamente dopo aver inserito tutte le viti, stringerle completamente.





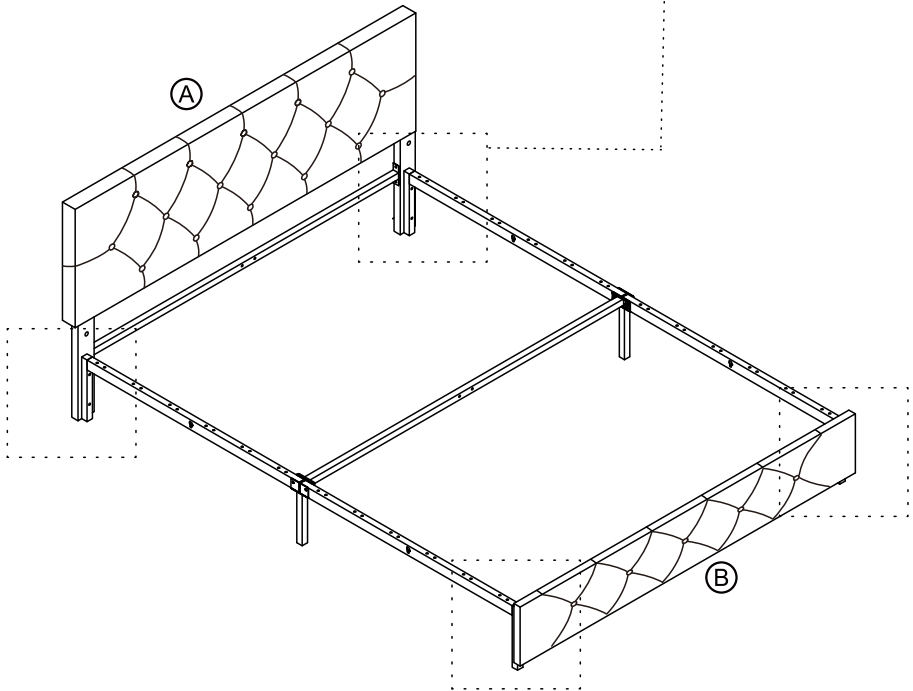
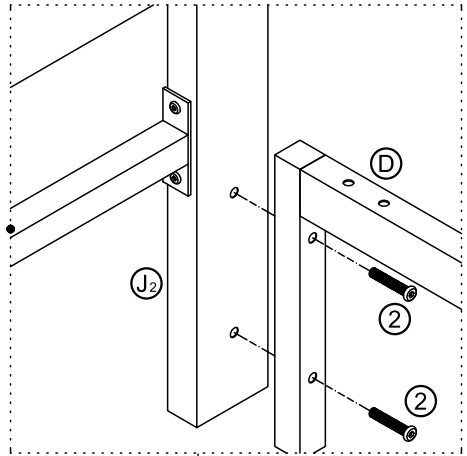

EN - Screw hole facing down.
DE - Schraubenloch zeigt nach unten.
ES - Apriete los tornillos hacia abajo.
FR - Vissez avec les trous vers le bas.
IT - Forare verso il basso.

4

②		x8
Ⓑ		x1



5

①		x4	③		x2
E ₁		x1	E ₂		x1
I		x1			

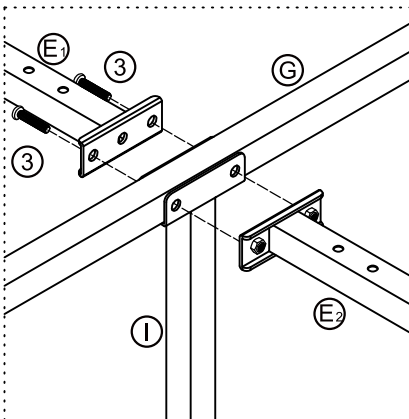
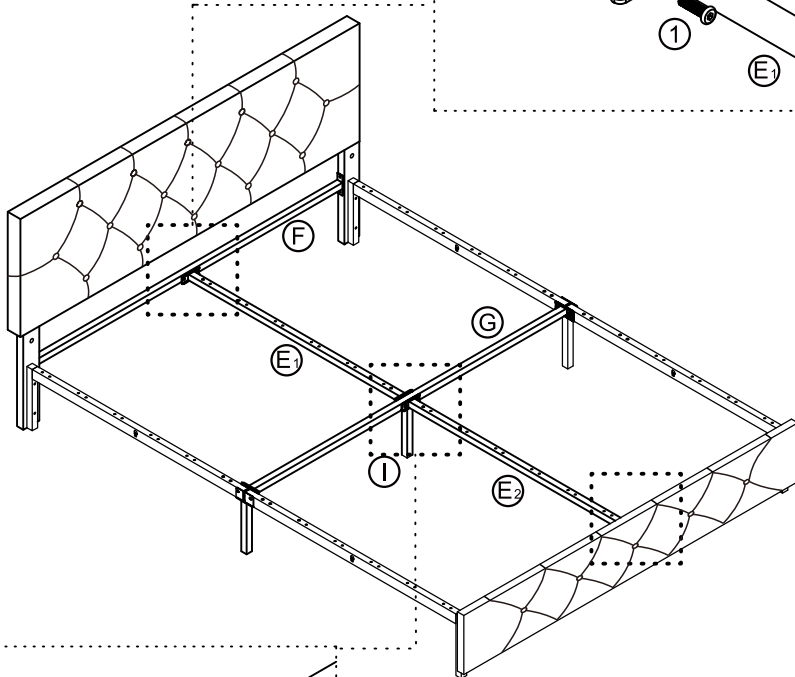
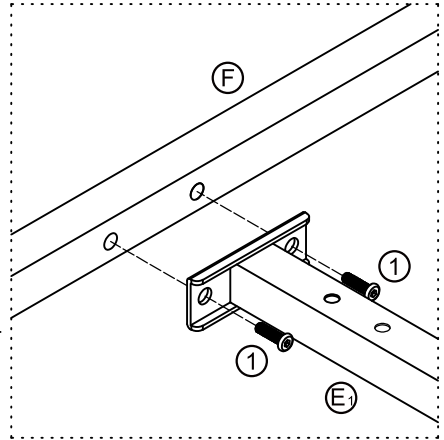

EN - When installing E2, please keep the side without nuts facing the end of the bed.



DE - Bei der Montage von E2 muss die Seite OHNE Schraubenmutter in Richtung zum Bettende zeigen.

ES - Al instalar la parte E2, mantenga el lado sin tuercas hacia el extremo de la cama.

FR - Pour l'installation d'E2, placez le côté sans écrous au pied du lit.

IT - Durante il montaggio della parte E2, si prega di mantenere il lato in modo che i dadi non siano rivolti verso il retro del letto.

6

(M)	 x24	(N)	 x12	(O)	 x24
-----	---	-----	---	-----	---

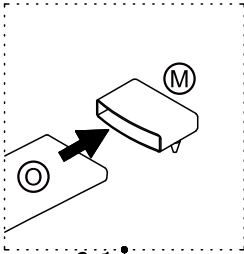

6.1

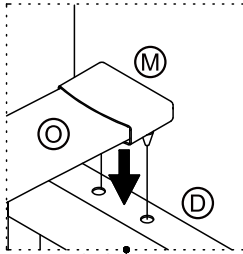

6.2

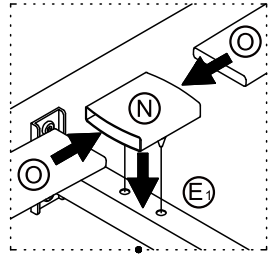

6.3

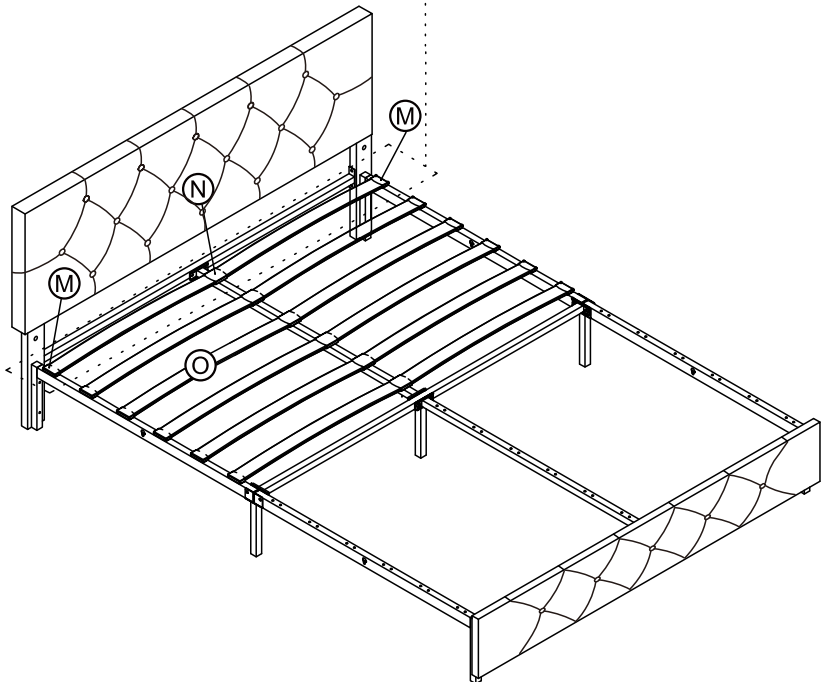

SLAT WARNING/SLAT WARNUNG/ADVERTENCIA SLAT/ AVERTISSEMENT LATTES/AVVERTENZA SLAT



- EN** - Correct: Slat curve should be facing upwards.
- DE** - Richtig: Lamellenkurve zeigt nach oben.
- ES** - Correcto: la curva de la plancha debe estar hacia arriba.
- FR** - Correct : la partie bombée des lattes doit être vers le haut.
- IT** - Corretto: la curva della doga dovrebbe essere rivolta verso l'alto.





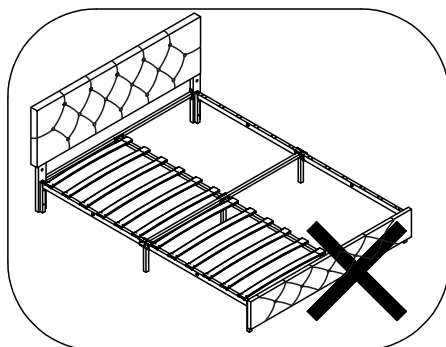
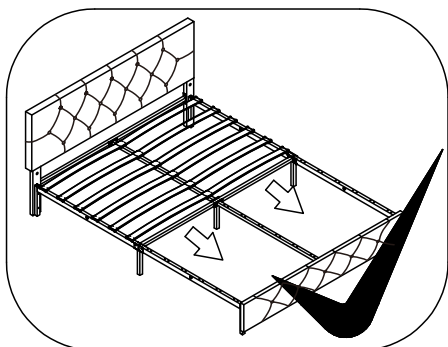

- EN** - Incorrect: Slat curve facing downwards.
- DE** - Falsch: Lamellenkurve zeigt nach unten.
- ES** - Incorrecto: la curva de la plancha está orientada hacia abajo.
- FR** - Incorrect : la partie incurvée des lattes est placée vers le bas.
- IT** - Sbagliato: la curva della doga è rivolta verso il basso.

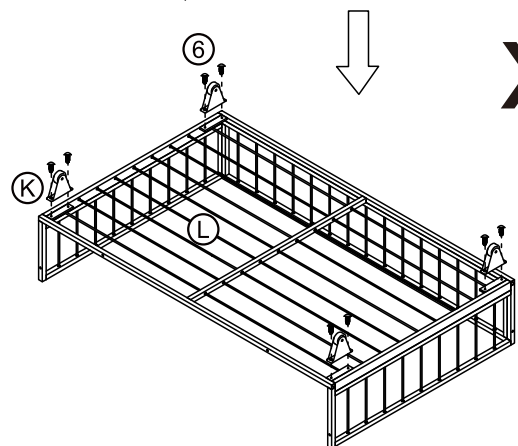
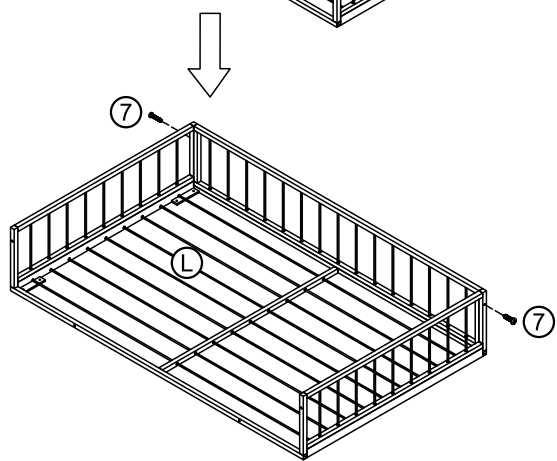
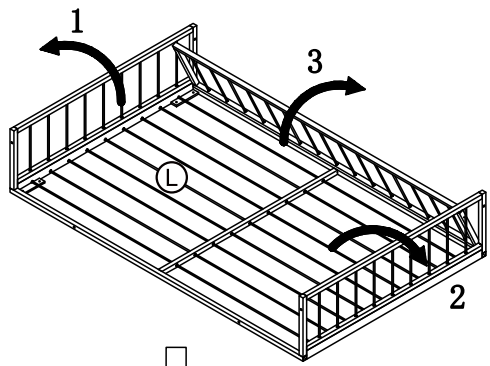
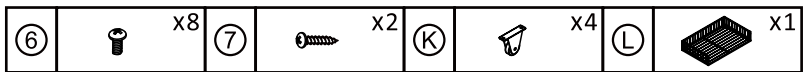

7



8

④	 x1	⑤	 x1	⑧	 x4	Ⓒ	 x1
---	--	---	--	---	--	---	--

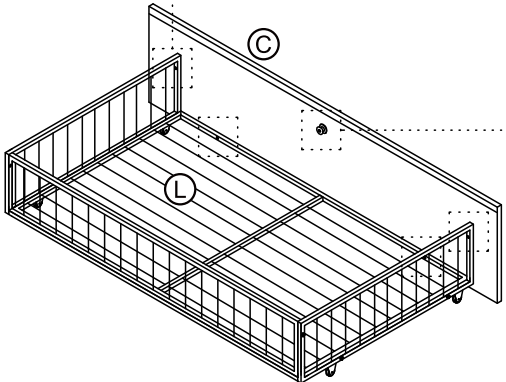
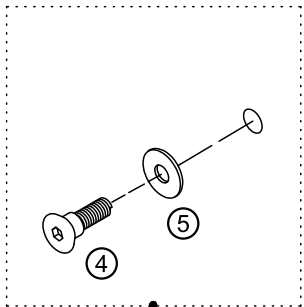
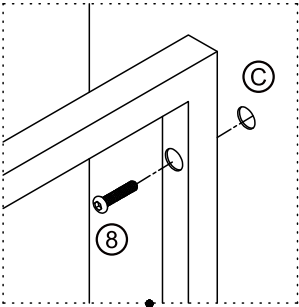

x4

