

# Assembly Instructions

⚠ Before you throw the carton, please ensure that you have all the parts needed for the assembly.

⚠ **Hardware Note:**  
1. For each step please don't fully tighten all the screws at first, when they all align to the holes you can fully tighten them.

2. All the bolts should be assembled **vertically** to the holes.

⚠ **Spare parts** can be found in the hardware box if you do not have enough bolts for assembly.

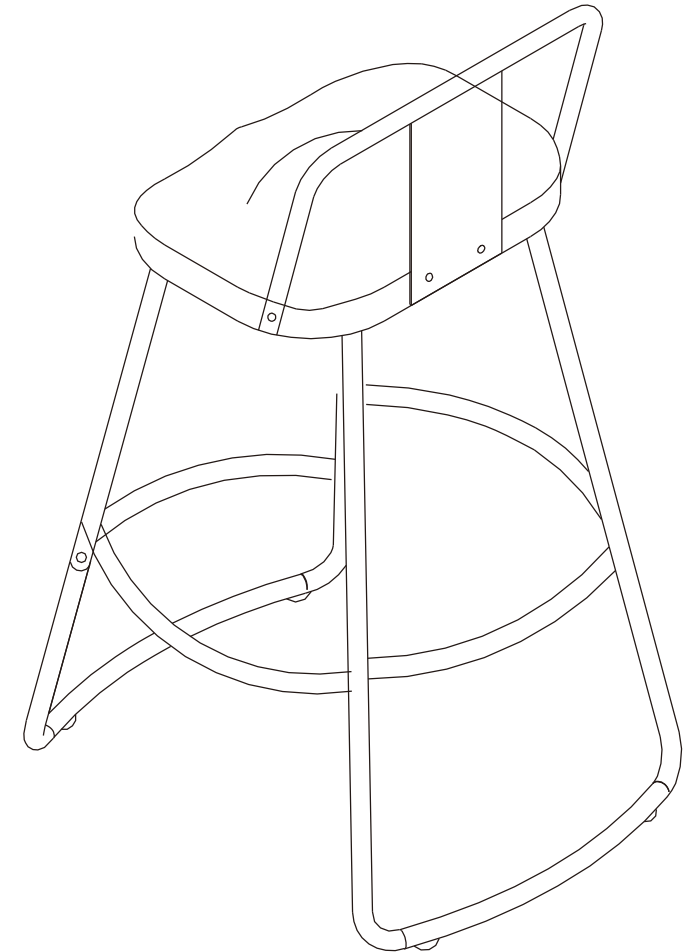

⚠ THIS INSTRUCTION BOOKLET CONTAINS IMPORTANT SAFETY INFORMATION. PLEASE READ AND KEEP FOR FUTURE REFERENCE.

# Assembly Instructions

MADE IN CHINA

## Parts and Hardware

Please check to make sure you have all parts and hardware before starting assembly process.

(A)

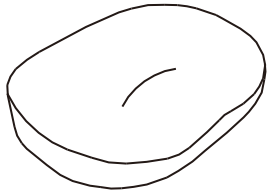

Seat 2pcs

(B)

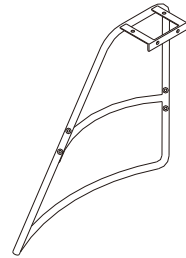

Legs 4pcs

(C)

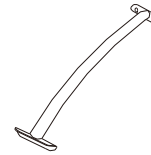

Connecting Rub: 4pcs

(D)

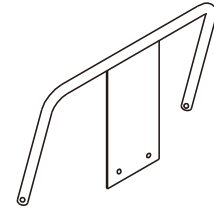

Back 2pcs

①

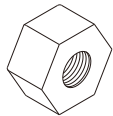

Nuts 4pcs

②



Long Bolts 4pcs

③

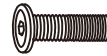

Short Bolts 16pcs

④



Allen Wrench 1pc

⑤

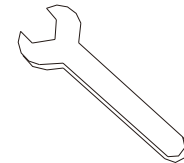

Wrench 1pc

# Assembly Instructions

MADE IN CHINA

## Assembly Instructions

STEP 1: Remove the bolts from legs (total 16 bolts).

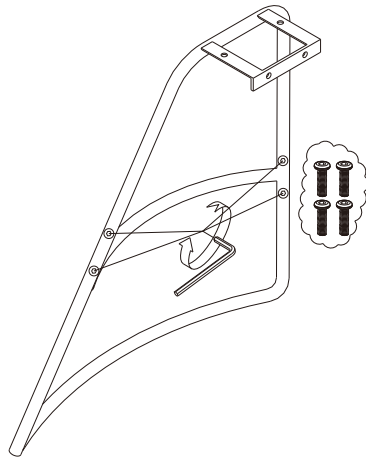

STEP 2: Assemble 2 legs use nut ① and long bolts ②.  
Do not fully tighten them.

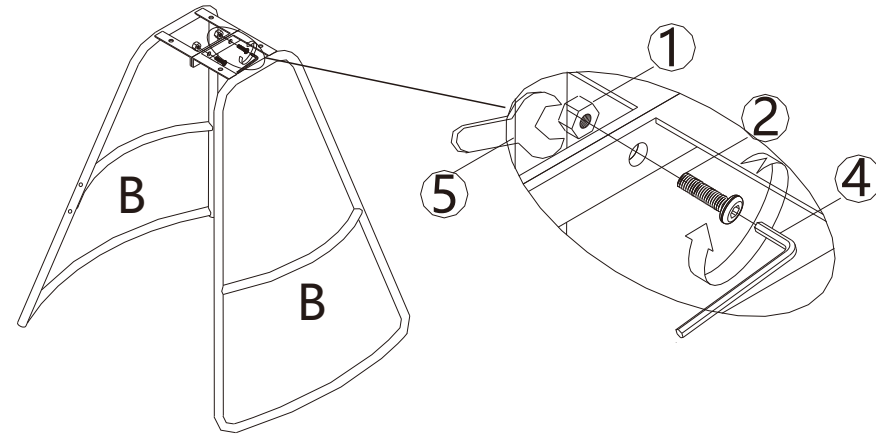

STEP 3: Use the bolts remove from legs to assemble connecting rub to legs. Do not fully tighten the bolts until they are align to the holes then fully tighten them by the short side of wrench (step 2 & 3).

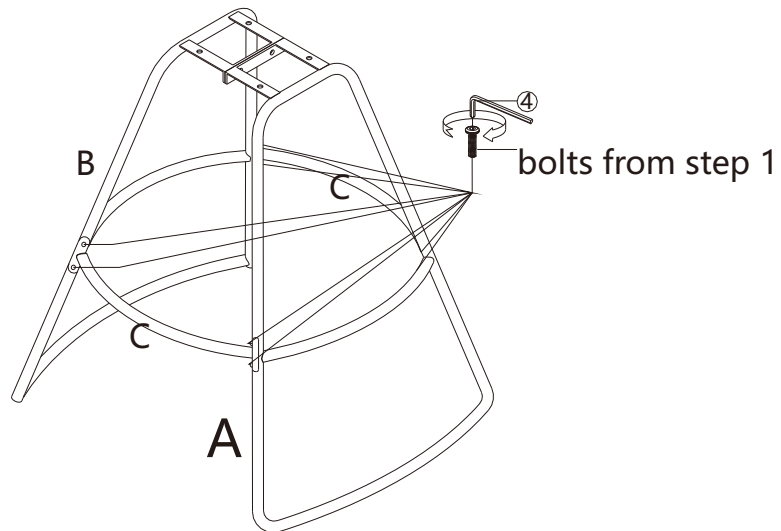

STEP 4: Assemble legs to seat use bolts ③.  
Do not fully tighten the bolts until they are align to the holes then fully tighten them by the short side of wrench.

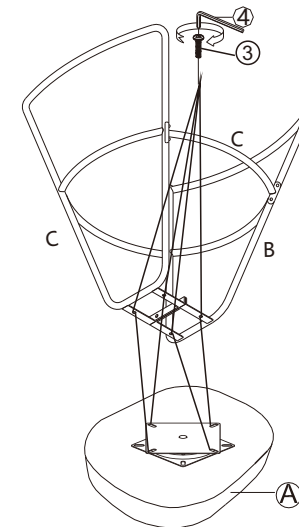

# Assembly Instructions

MADE IN CHINA

## Assembly Instructions

STEP 5: Assemble the back to seat use bolts (3). Do not fully tighten the bolts until they are align to the hole then fully tighten by the short side of wrench.

