

User Manual

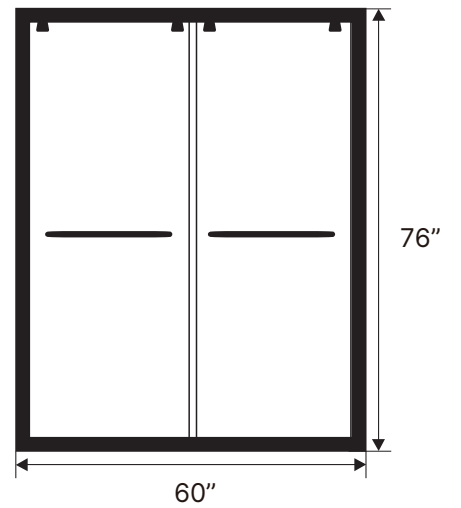

Double Slide Outer Frame
Shower Door(Doors Only)

Please read before using it :)

English

Caution: The corners of tempered glass panels are the most fragile. Therefore, it's essential to use rubber blocks to ensure the glass never touches the tile surface during installation. Always place the glass on cardboard packaging or rubber blocks when it's out of its packaging, both before and during installation. We use rubber blocks to protect the glass, but you can also use wood, cardboard, or other rubber products to prevent breakage.

Attention Installer: A light haze or smudging may be present on the coated glass panels upon delivery. This can be easily removed using alcohol and a high-quality microfiber cloth, followed by rinsing with water. You can clean the glass either before or after installation.

Easy clean coating

Do not clean with strong acid and alkali detergents;
Do not clean with high-concentration alcohol;
Do not wipe with hard and sharp objects.

Español

Precaución: Las esquinas de los paneles de vidrio templado son las más frágiles. Por lo tanto, es esencial utilizar tacos de goma para garantizar que el vidrio nunca toque la superficie de la baldosa durante la instalación. Coloque siempre el vidrio sobre un embalaje de cartón o tacos de goma cuando esté fuera de su embalaje, tanto antes como durante la instalación. Utilizamos tacos de goma para proteger el vidrio, pero también puede utilizar madera, cartón u otros productos de goma para evitar que se rompa.

Atención, instalador: Es posible que los paneles de vidrio revestidos presenten una ligera neblina o suciedad al recibirlos. Esto se puede eliminar fácilmente con alcohol y un paño de microfibra de alta calidad, seguido de un enjuague con agua. Puede limpiar el vidrio antes o después de la instalación.

Capa de limpieza fácil

No se recomienda limpiar con detergentes ácidos y alcalinos fuertes;
No se recomienda limpiar con alcohol de alta concentración;
No se recomienda limpiar con objetos duros para limpiar.

繁體中文

注意：強化玻璃面板的邊角是最脆弱的。因此，在安裝過程中必須使用橡膠塊來確保玻璃不會接觸到磁磚表面。在安裝之前和安裝過程中，打開包裝後，請務必將玻璃放在紙板包裝或橡膠塊上。我們使用橡膠塊來保護玻璃，但您也可以使用木頭、紙板或其他橡膠製品來防止破損。

安裝人員請注意：交貨時，鍍膜玻璃面板上可能會出現輕微的霧氣或污跡。可以使用酒精和優質超細纖維布輕鬆去除，然後用水沖洗。您可以在安裝之前或之後清潔玻璃。

易潔圖層

不建議強酸強鹼清潔劑清潔；
不建議使用高濃度酒精清潔；
不建議使用硬物擦拭。

日本文

注意：強化ガラスパネルの角は最も壊れやすい部分です。そのため、設置中にガラスがタイルの表面に触れないように、ゴムブロックを使用することが重要です。設置前と設置中は、梱包から取り出したガラスを常に段ボールの梱包またはゴムブロックの上に置いてください。当社ではガラスを保護するためにゴムブロックを使用していますが、破損を防ぐために木材、段ボール、その他のゴム製品を使用することもできます。

設置者への注意：配送時にコーティングされたガラスパネルに軽い曇りや汚れがある場合があります。これはアルコールと高品質のマイクロファイバークロスを使用して簡単に取り除き、その後水で洗い流すことができます。ガラスは設置前でも設置後でも清掃できます。

簡単にきれいな層

強い酸やアルカリ性の洗剤での洗浄はお勧めできません。
クリーニングに高濃度のアルコールを使用することはお勧めできません。
硬いものを使用して拭くことはお勧めできません。

You may need these...



Level

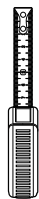

Tape Measure



Pencil

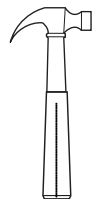

Hammer



Screwdriver



Safety Goggles

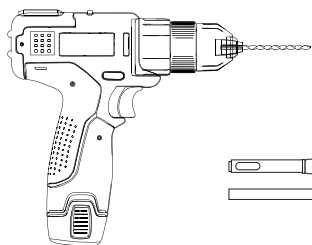

Electric Drill

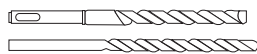

Φ6mm Masonry Drill
Φ3.2mm HSS Drill

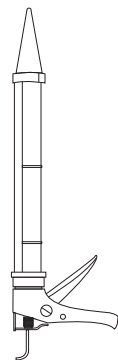

Caulking Gun

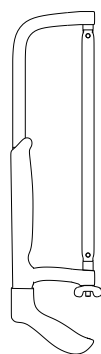

Hacksaw

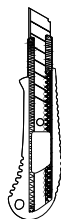

Cutter

What's inside?

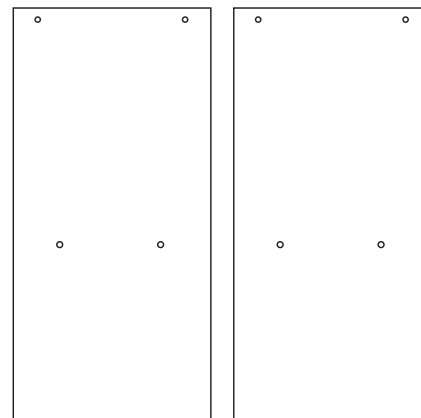

A

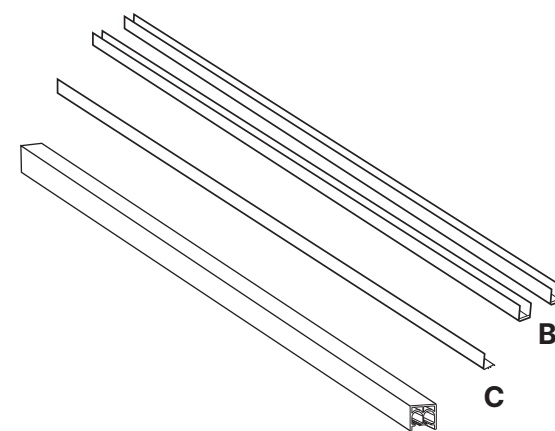

B

C

D

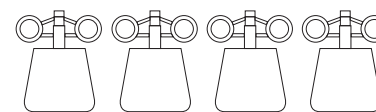

E

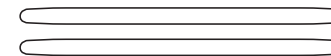

F



G



H

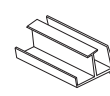

I



J

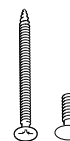

K



L

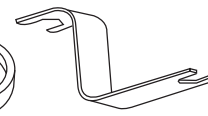

M

- A Glass Door x2
- B Wall Profile x2
- C Bottom Rail x1
- D Top Rail x1
- E Hanging Wheel x4
- F Handle x2

- G Decorative Cover for Top Rail x2
- H Bumper Block x6
- I Slide Block x1
- J Wall Anchors
- K Screws Group
- L Hex Key x1
- M Hexagon Spanner for shower door x1

1

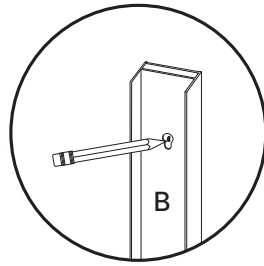
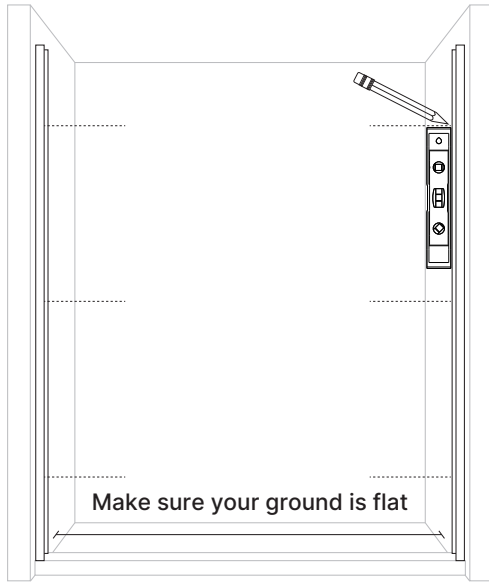

Use A1 and B to locate drilling position

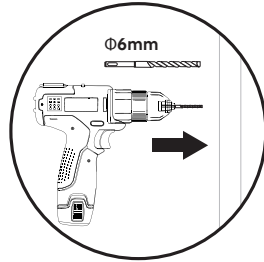

! Before drilling, please remove A1 and B first.

3



Please move one glass door in first before installing top track.

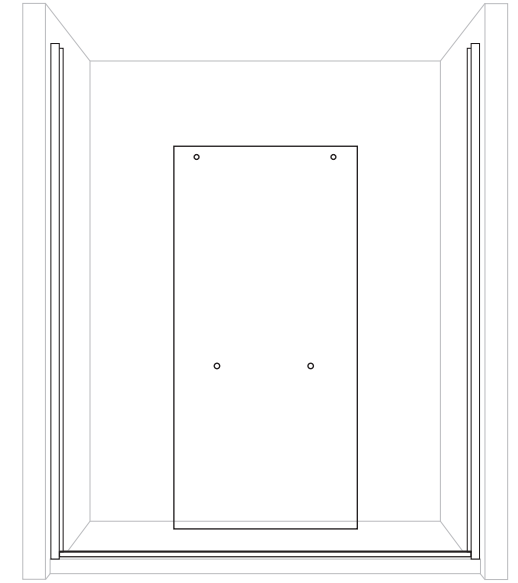

2

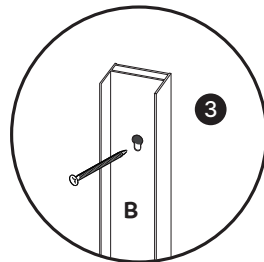
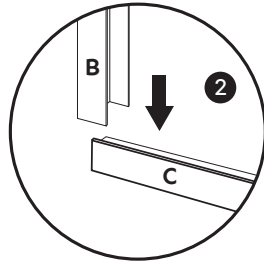
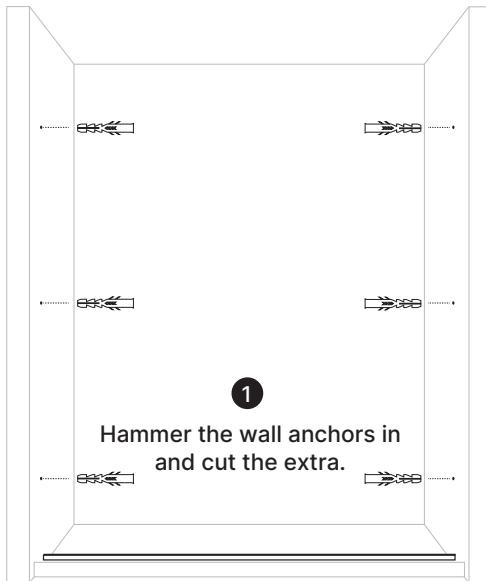

4

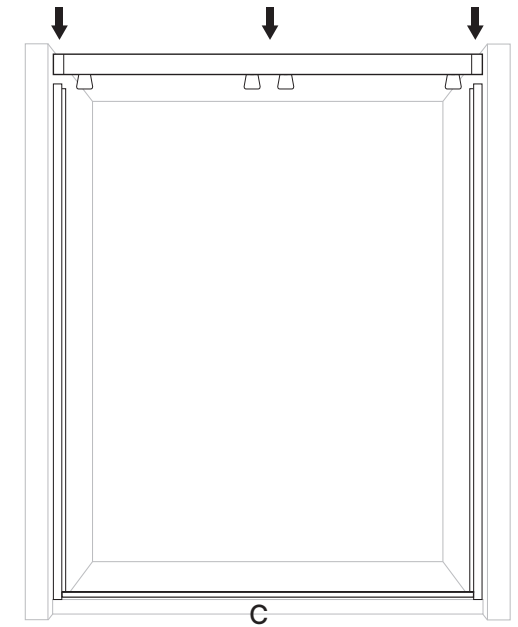
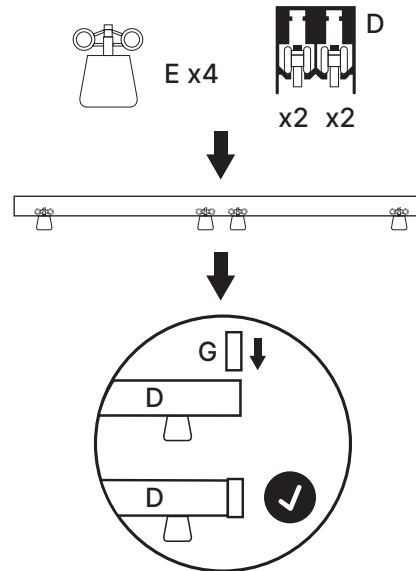

5

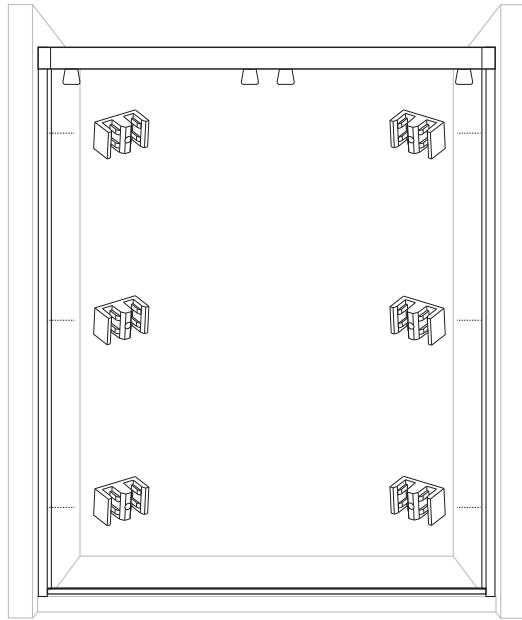
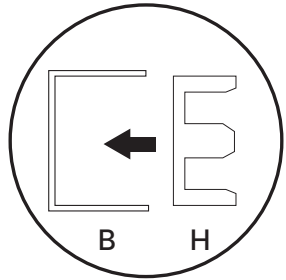

6

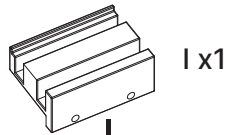

↓
This side should face outside

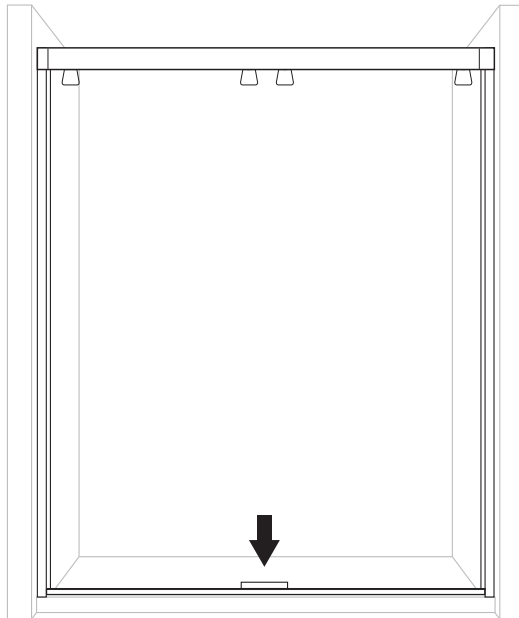

7

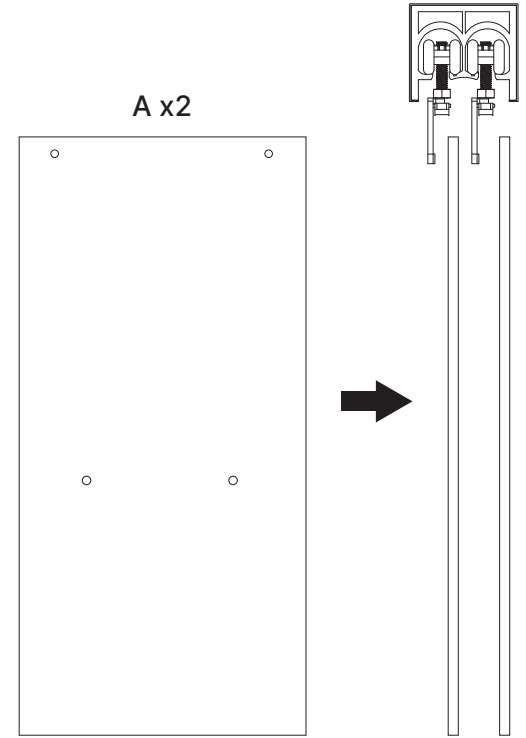
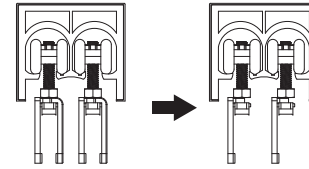

⚠ Please install 1 door first

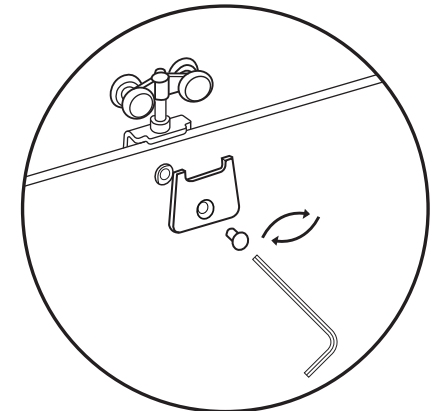
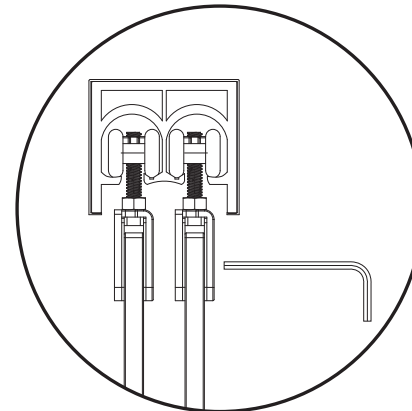

8

F x2

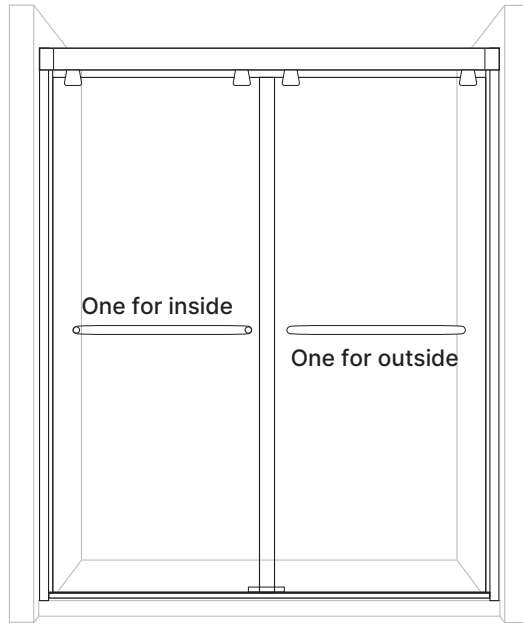
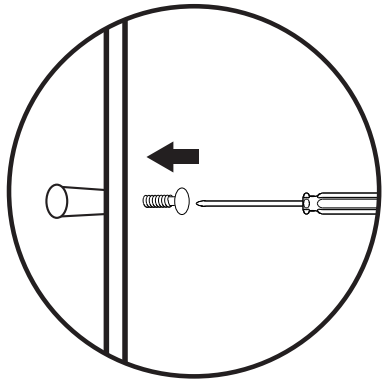

10

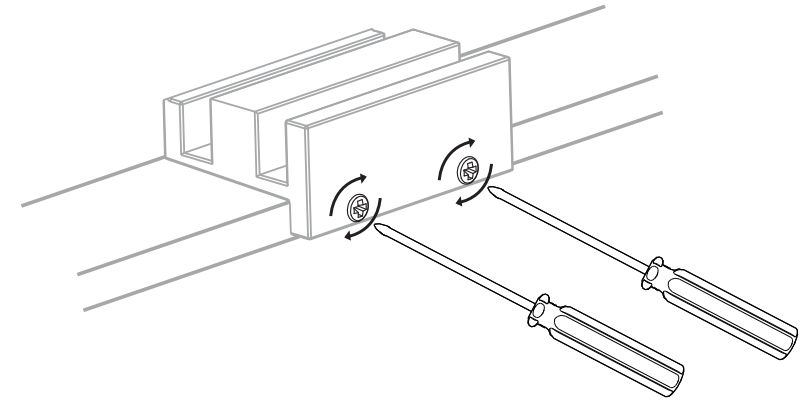

11

9 Almost there!

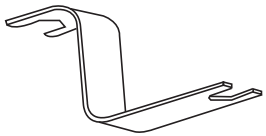

M x1

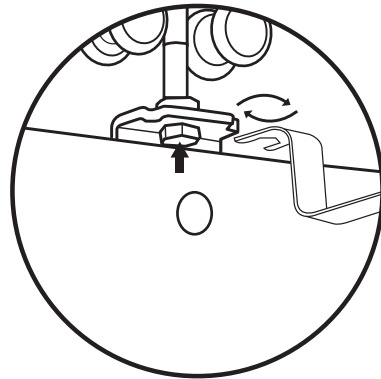

For glass alignment adjustment, please rotate the screw here.

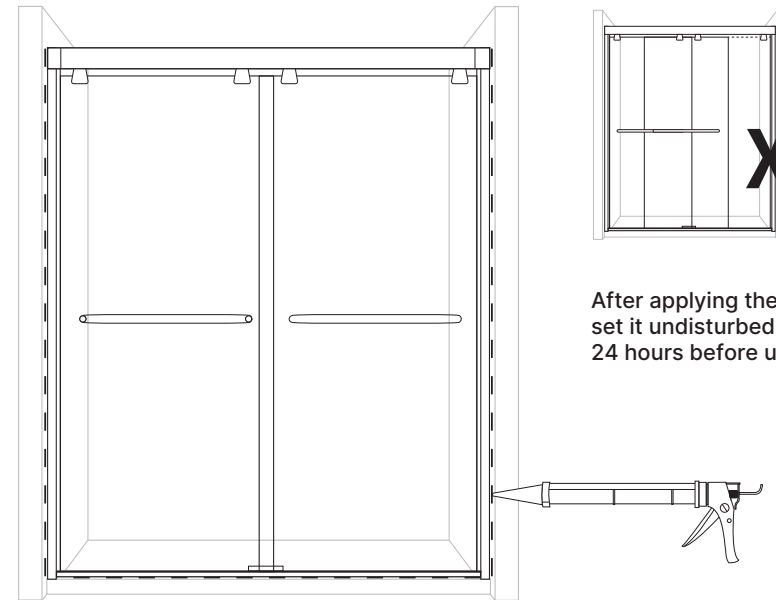

X <24h

After applying the adhesive, set it undisturbed for at least 24 hours before use.