

3 Seater Recliner Sofa

Operating Instruction

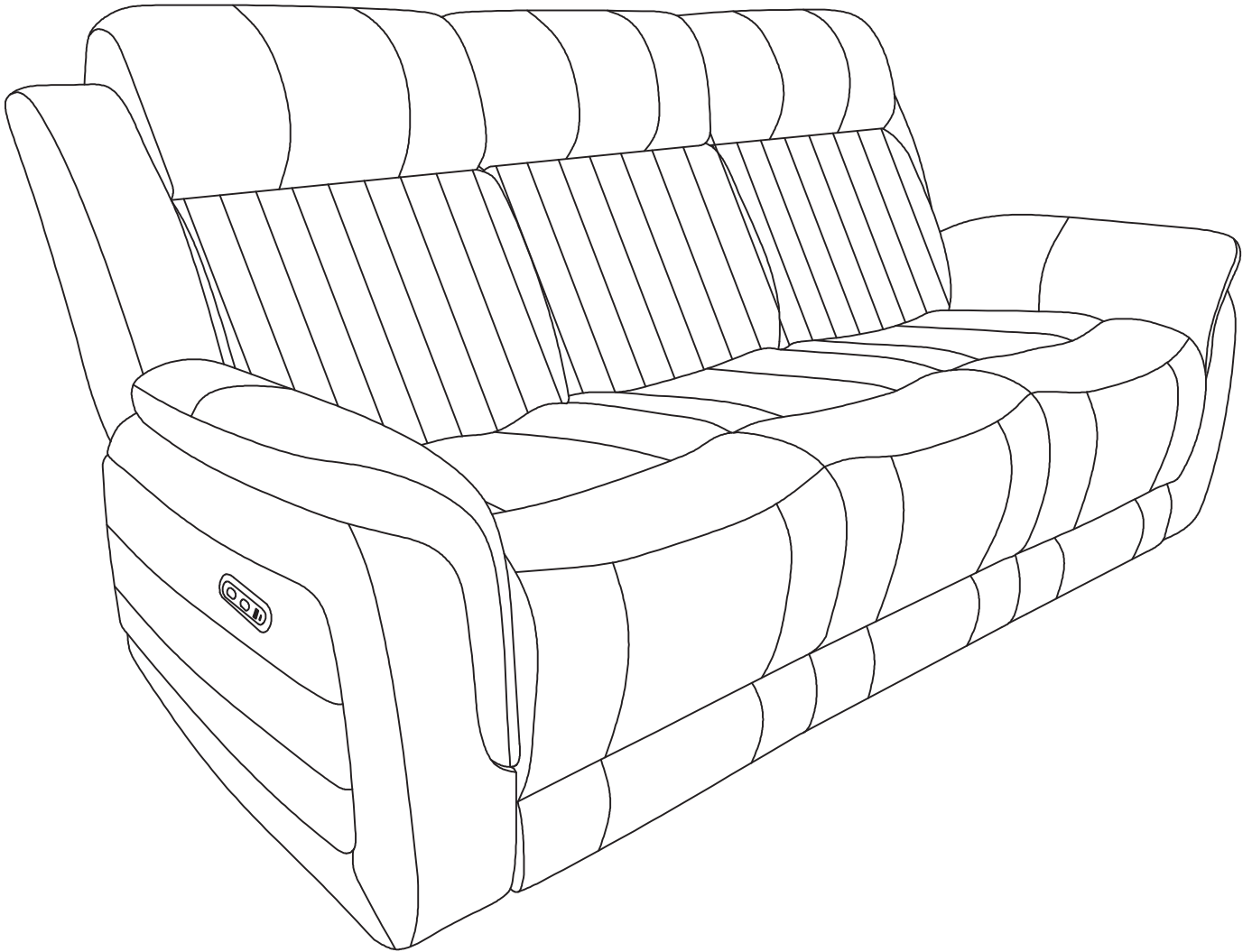

NOTE: This sofa is shipped in 4 boxes. All accessories included.
If you have any questions after receiving the sofa, please contact
us in time and provide pictures. We will try our best to help you solve it.

ATTENTION

Thanks for choosing our product.

- 1. There will be 4 boxes in total for this whole product. Please check the manual carefully and make sure you have received all the parts.**
- 2. If there is any missing or damaged parts, please let us know the name and number of the parts you need.**
- 3. If there is any damage parts, please send clear photos to us, we will check and offer you best solution soon.**
- 4. There may be a little color difference between the picture and the real thing.**
- 5. Unplug all power cord and wires connection from socket before move chair. Disconnect all the power when not in use.**



Do not smoke or play with fire

PARTS LISTING

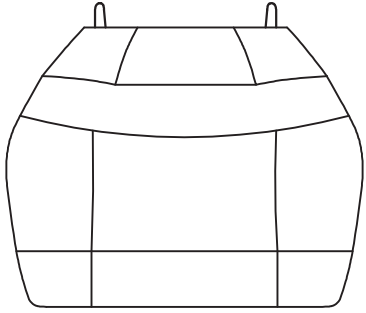
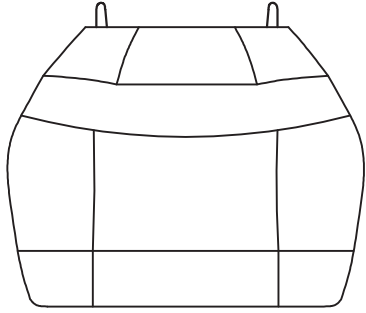
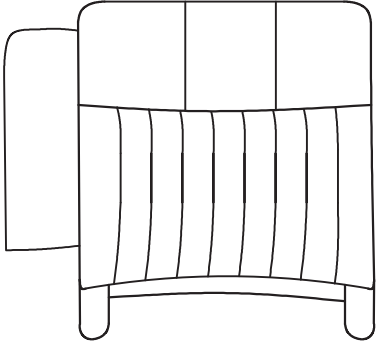
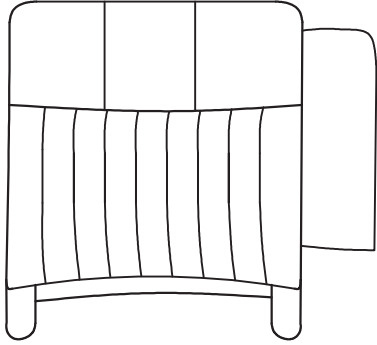
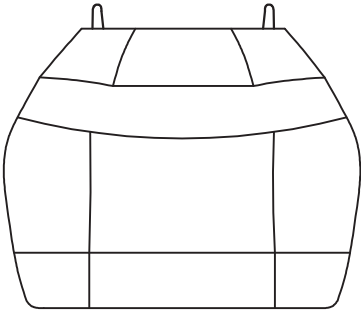
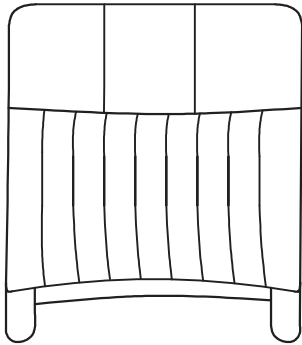
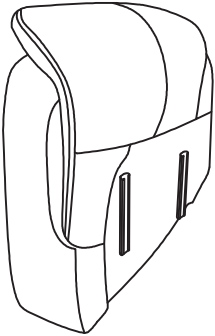
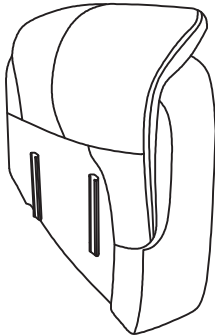
Part	Description	Qty	Part	Description	Qty
A1		1PC	A2		1PC
B1		1PC	B2		1PC
C		1PC	D		1PC
E		1PC	F		1PC

HARDWARE BOX

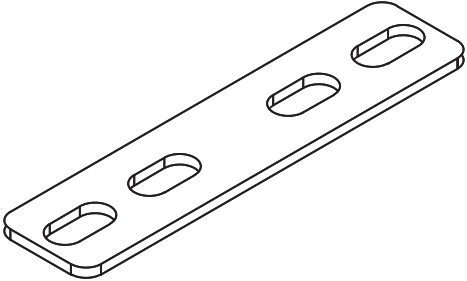
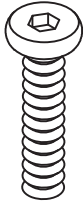
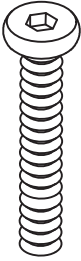
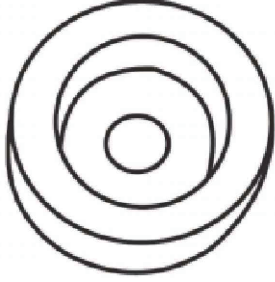
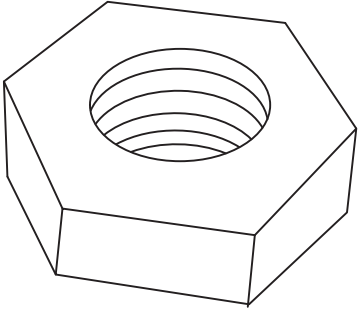
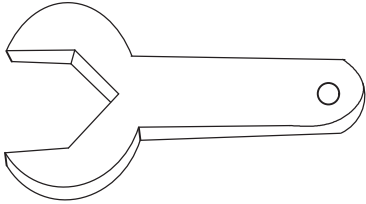
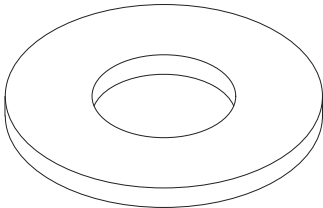
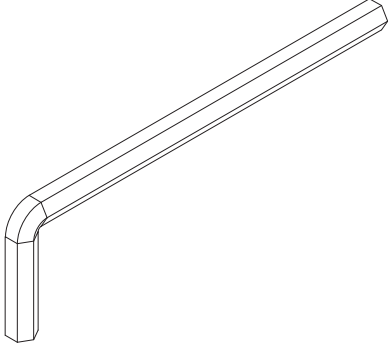
Part	Description	Qty	Part	Description	Qty
G		4PCS	H	 M6*20	9PCS
I	 M6*30	5PCS	J		5PCS
K		9PCS	L		1PC
M		13PCS	N		1PC

HARDWARE BOX

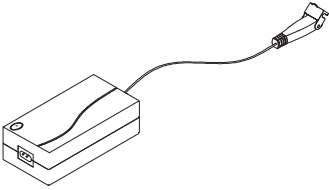
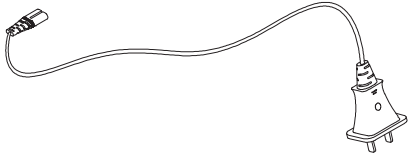
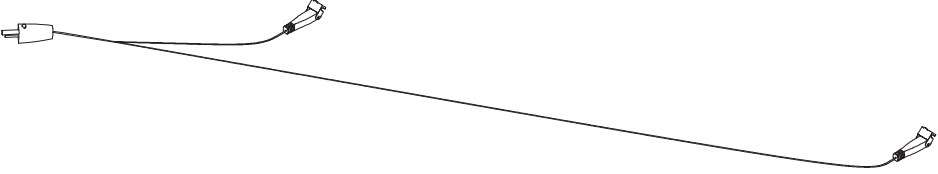
Part	Description	Qty	Part	Description	Qty
O		1PC	P		1PC
Q					1PC

STEP 1

Note:

For the convenience to adjust parts connection, never fully tighten the screws until you finish the installation, tighten screws to 80%-90% is enough.

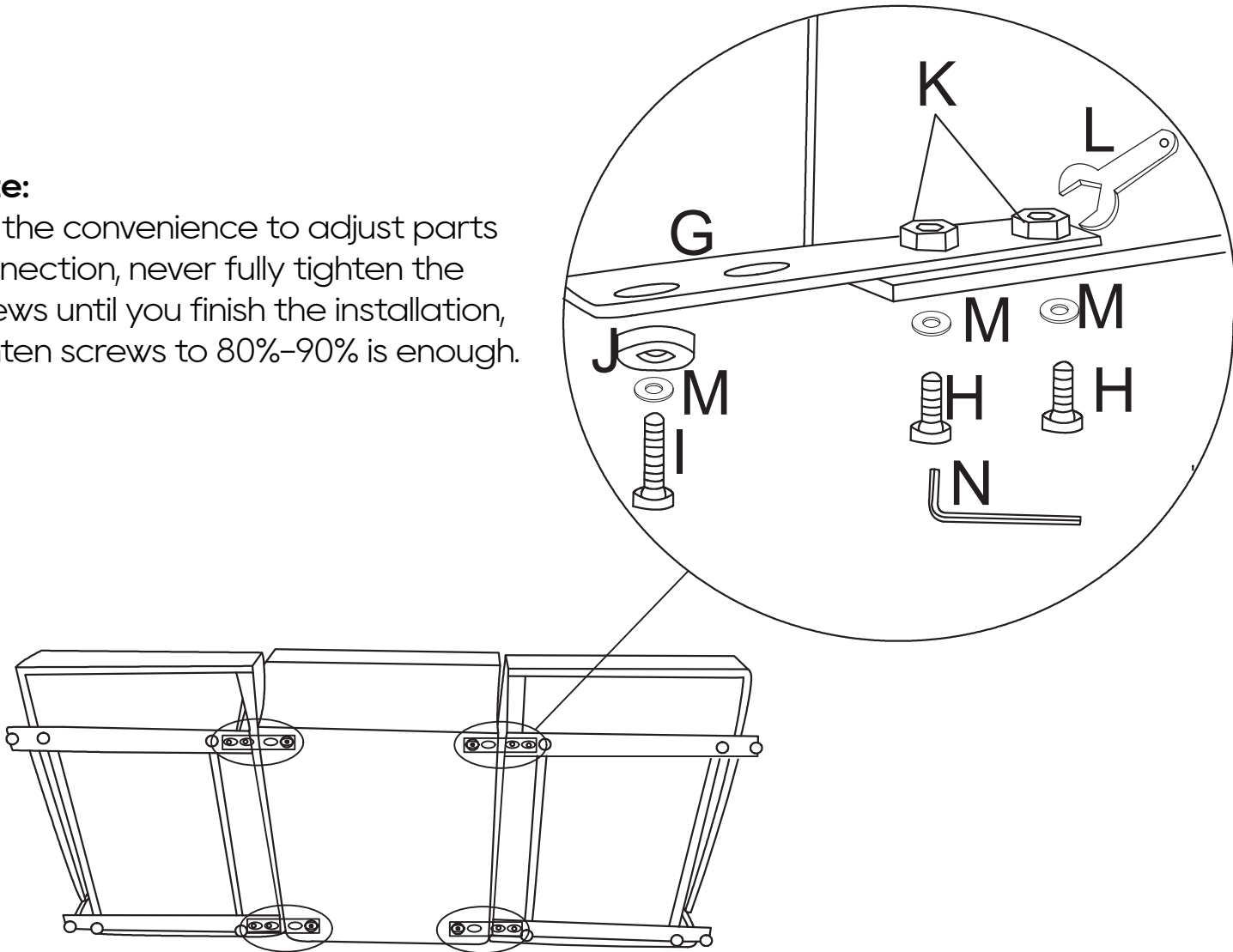

Accessories:

Part G*4, Part H*8, Part I*4, Part J*4, Part K*8, Part L*1, Part M*12, Part N*1.
Turn the bases upside down and align them. Two pieces of iron (Part G) at the front and back connect the left and right bases with the console.
Align the two holes on the base and the holes of the iron sheet, and then connect with Part H, M, K. (with the shorter screws)
Align the hole on the middle base and the holes of the iron sheet, then connected with Part I, M, J. (with the longer screws) As shown in the figure.

STEP 2

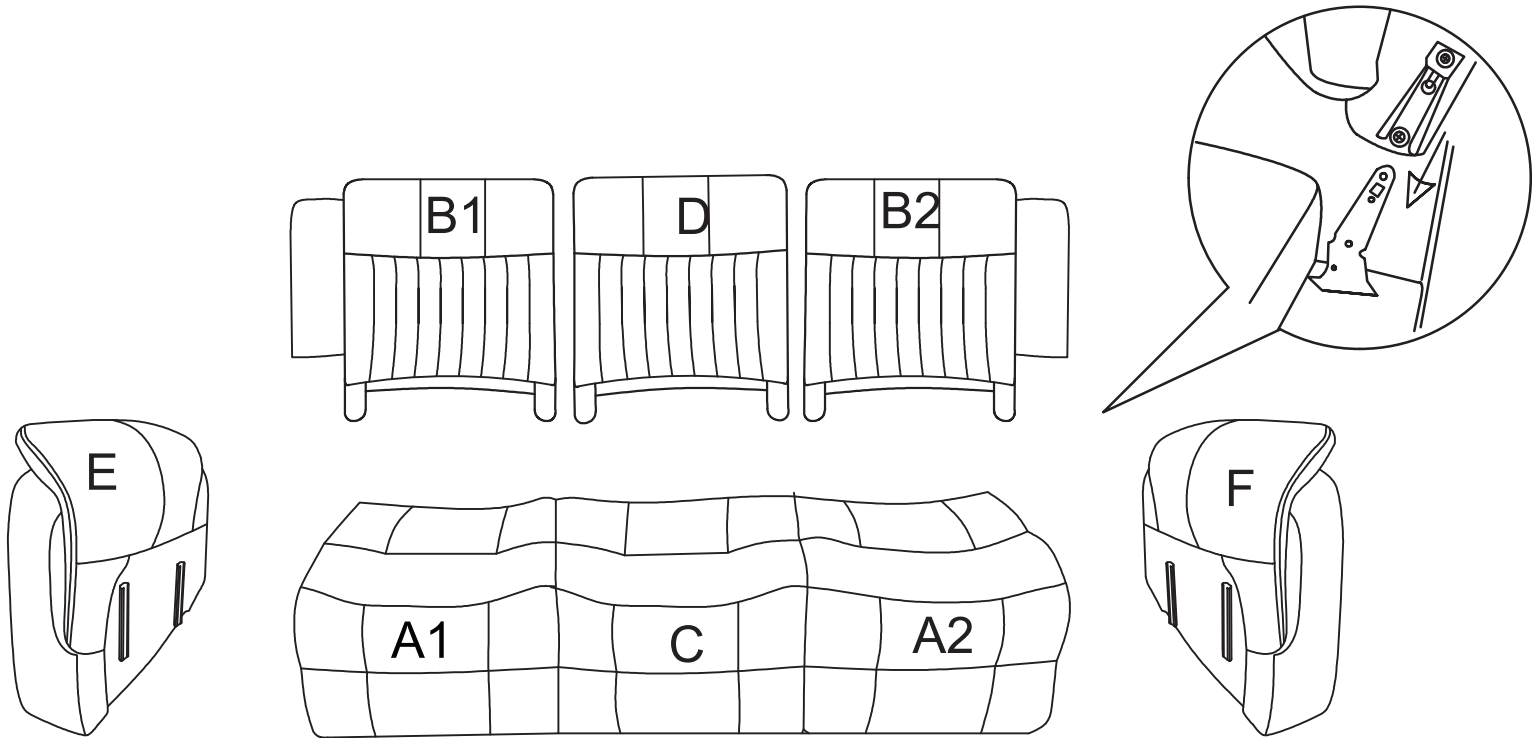

Accessories:

Part A1*1, Part B1*1, Part A2*1, Part B2*1, Part C*1, Part D*1, Part E*1, Part F*1.
Align the inserts on the armrest and the base, connect Part E to Part A1 first, then connect Part F with Part A2, and then connect Part B2, Part B1, Part D with corresponding Part A2, Part A1, Part C.

Pay attention to pressing down hard to ensure that the insert is inserted in place to avoid shaking or tilting.

STEP 3

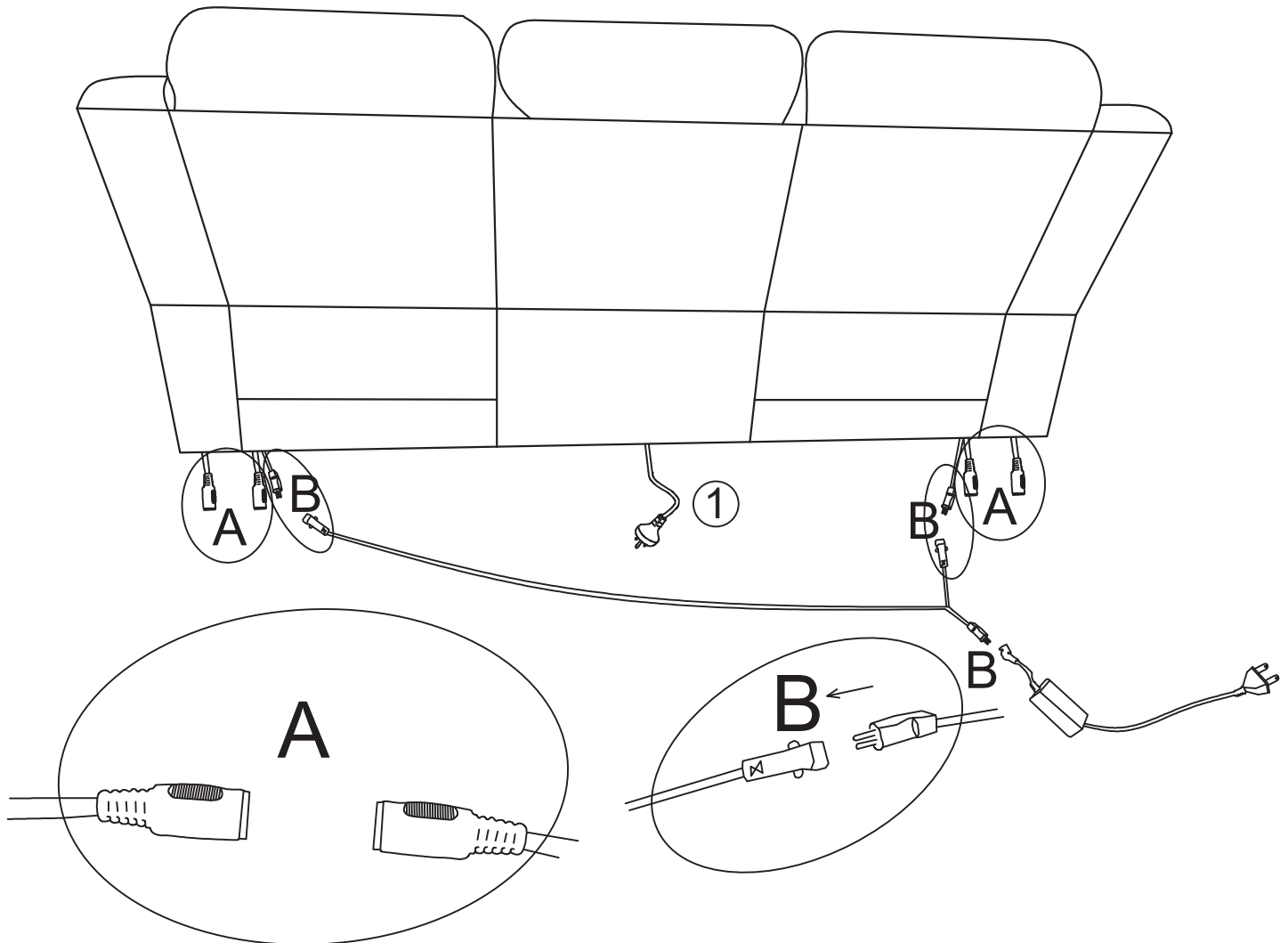

Accessories: Part O*1, Part P*1, Part Q*1.

NO 1. Connect the wiring at the bottom of both armrests to the wires on the base. As show in circle A.

NO 2. Connect the Y-shaped line (Part Q) to the corresponding hole on each seat base.

NO 3. Connect Part Q with Part O(Power Source). As show in circle B.

NO 4. Connect Part O with Part P(Wire).

NO 5. ① plug is under the base, just pull it out and plug it into the power supply, that is control the middle backrest socket.

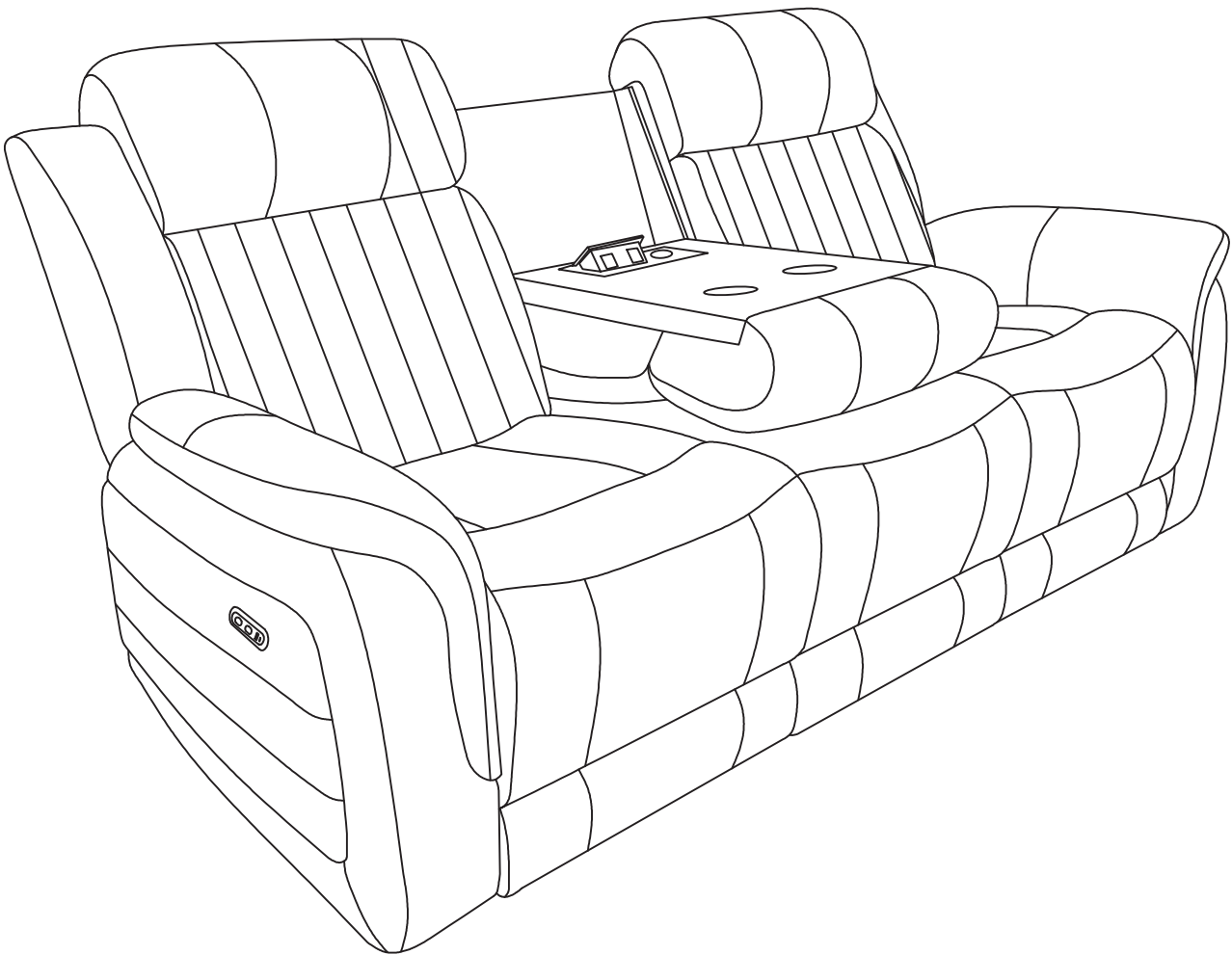

Congratulations on completing the assembly and you can use this power recliner sofa now. After power on, you can control the tilt angle of the sofa through the button beside the armrest. Of course, the middle back of this sofa can be flipped to become an elevating storage console with two cup holders. Hope you will like our sofa.

Note: Please disconnect the power when not in use to avoid accidents.