

WARRANT

We strive to offer high-quality product and we also try our best to satisfy each customer that orders from us with product or service as needed.

Each customer a record of their order such as the order number, or item receipt for any items that are out of the warranty period you may also still receive replacement parts by purchasing them with our company if they are available.

Are you having difficulty
with assembly? Missing parts?

Please contact us : info@firstopintl.com
telephone No. : 5627813327

send an email with your order No. to us

For return, please check the return policy with
the retailer or market place you bought from.

Appreciate your purchasing from us.

Pop up your life by our furniture !

wixe

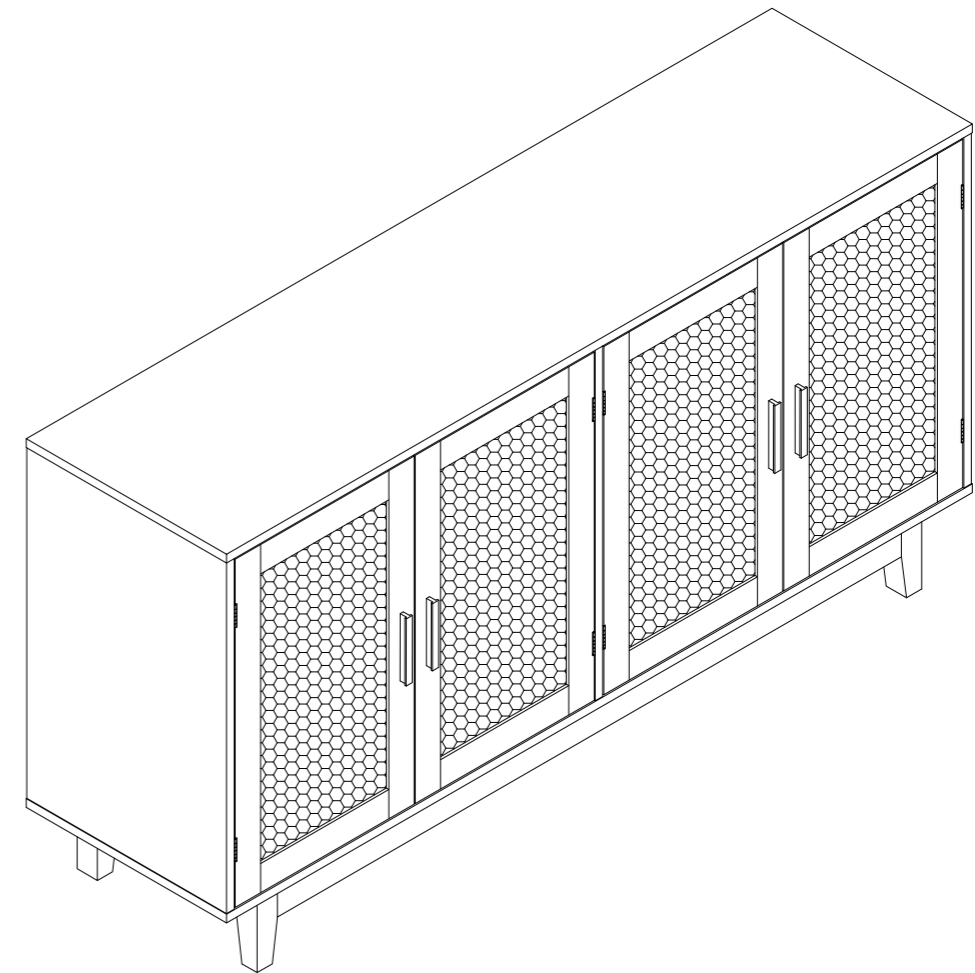

ITEM NO. CB0007

NOTE :

This brochure contains IMPORTANT safety info. Please read
and keep for future reference.

ATTENTION

- 1. A person who is proficient in assembly can work alone, if not, please ask someone to cooperate with this job.
- 2. When assembling the parts, please follow the orders, methods and positions of the assembly instruction.

If meeting any difficulties, please check with the instruction carefully first.

- 3. It will take about 3 hours to complete the assembly for those who are new in this field.
- 4. When assembling, at least six- square- meter space is requested.
- 5. Pay attention to the below instructions for componets assembly.
- 6. Any problems during the assembly, please contact us with email info@firstopintl.com or telephone us by 5627813327.

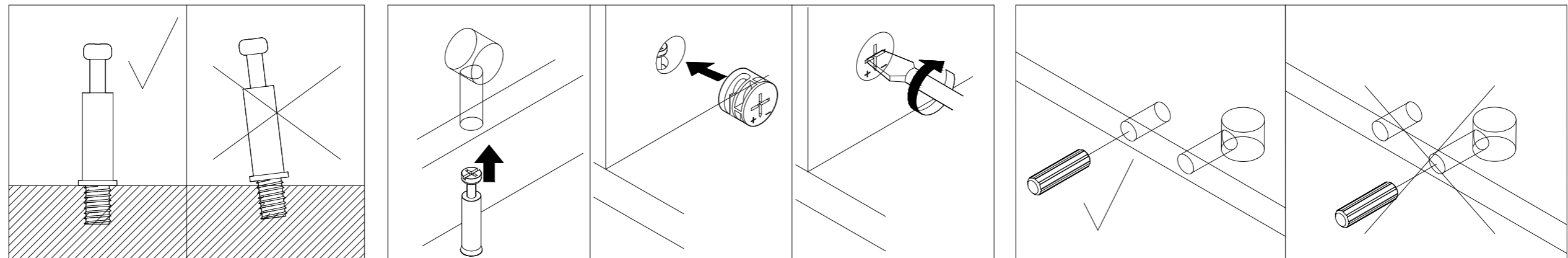

MAINTAINANCE AND WARNING

- Keep furniture away from heat and fire.
- Keep furniture away from sharp objects.
- Do not clean furniture with harsh cleansers or polish. Do not use detergents, Solvents, abrasives, spray packs or leather cleaner. Use non-color mild soap with warm water clean spills(Mix 1:10 soap to water)
- Do not place furniture under direct sunlight, material will possibly fade over time.
- Do not jump or strike on the furniture.
- Do not write on furniture without a padded barrier to protect the surface.
- Not for commercial use, For residential use only.

Weight Limitation
 **100LBS**

PARTS LIST

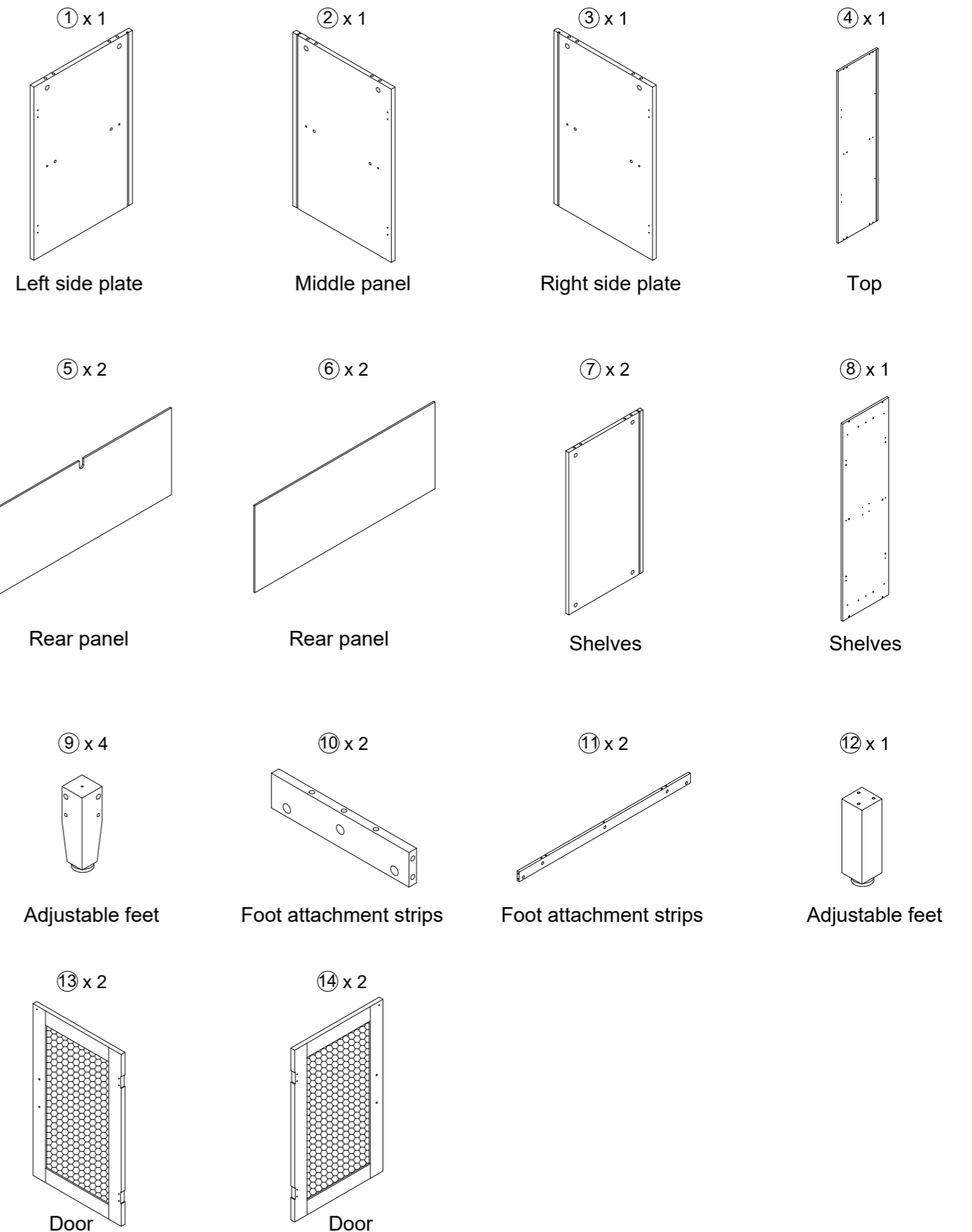

PARTS LIST

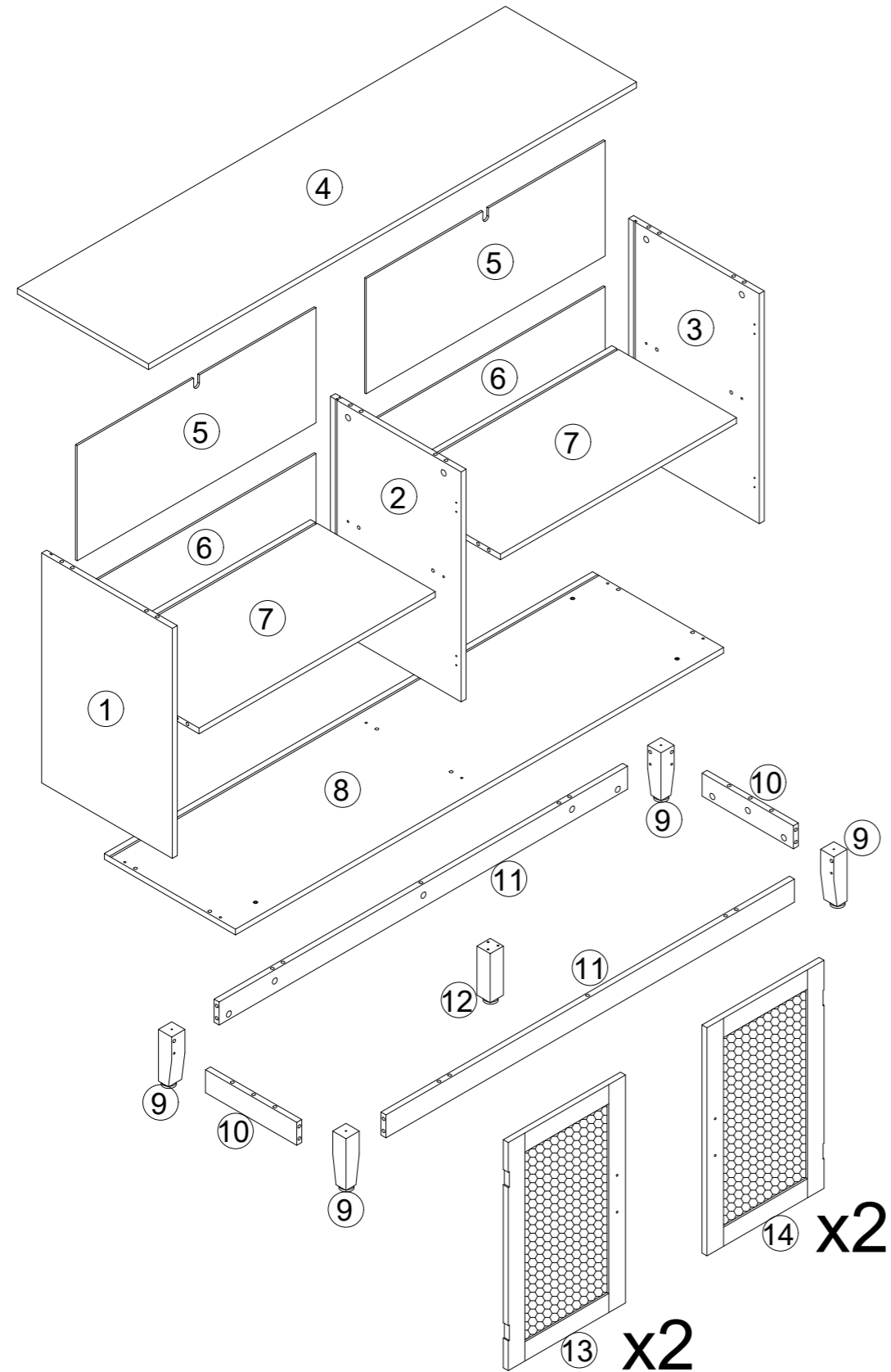

HARDWARE and TOOL LIST

A x 30+2

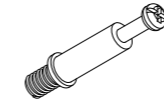

Cam bolt
Ø6x35mm

B x 30+2

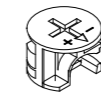

Cam lock
Ø15x12mm

C x 32+2

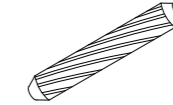

Wood dowel
Ø8x30mm

D x 4

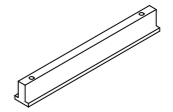

Handle

E x 8

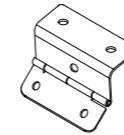

Hinge

F x 24+2



Screw
M3x14mm

G x 40+2



Screw
M3.5x12mm

H x 6



Screw
M4x14mm

I x 8



Screw
M4x18mm

J x 3

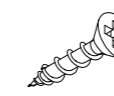

Screw
M4x25mm

K x 12+1

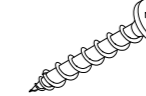

Screw
M4x35mm

L x 16+1

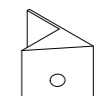

Back plate buckle

M x 2

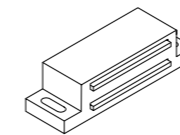

Magnetic

N x 4

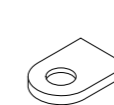

Magnetic iron sheet

O x 2

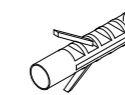

Wall plug
Ø6x30mm

P x 1

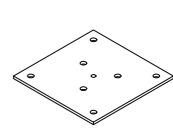

Iron sheets

Q x 2

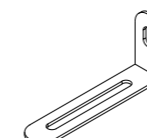

Lock-the-wall
iron plate

R x 2



Wood dowel
Ø8x50mm

Z X1



Screwdriver

SPARE

A x 2

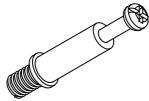

Cam bolt
Ø6x35mm

B x 2

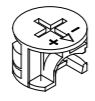

Cam lock
Ø15x12mm

C x 2



Wood dowel
Ø8x30mm

F x 2



Screw
M3x14mm

G x 2



Screw
M3.5x12mm

K x 1

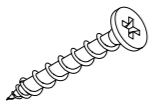

Screw
M4x35mm

L x 2

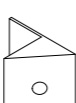



Back plate buckle

Be sure to check all packing material fitting the packing list. Be careful for small parts, which may have come loose inside the carton during shipment.

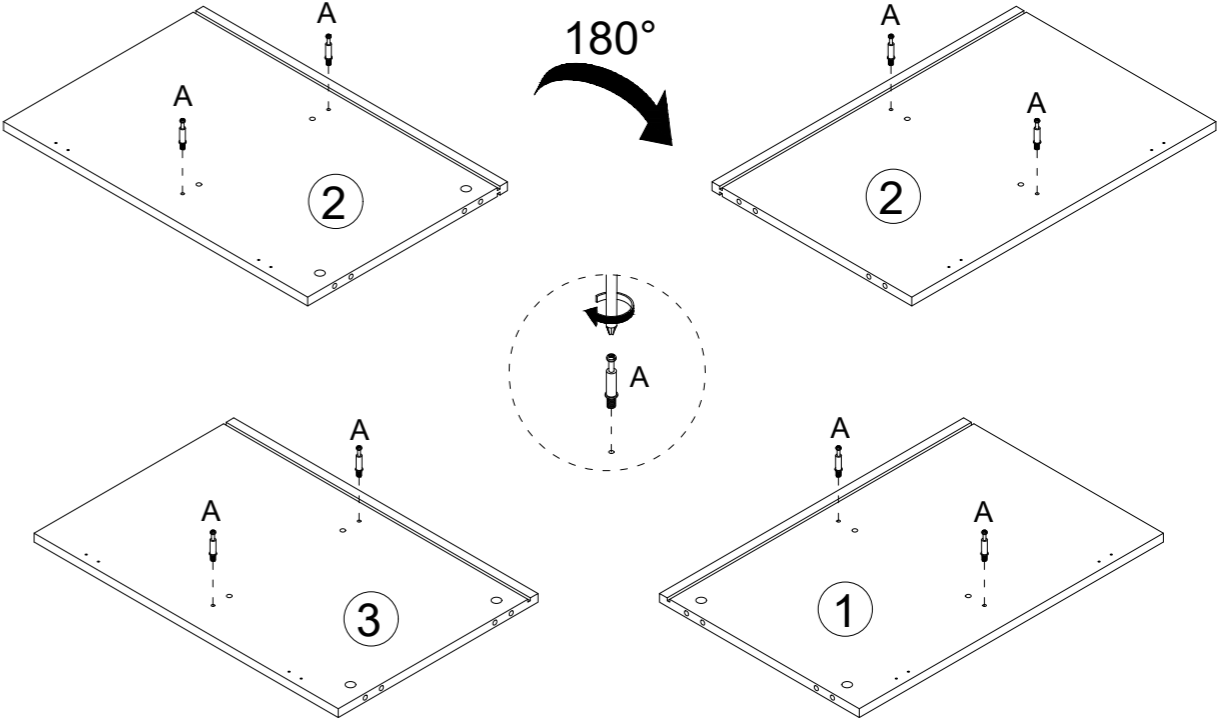
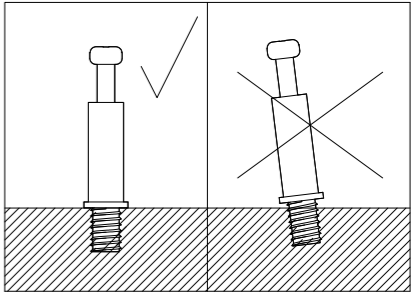
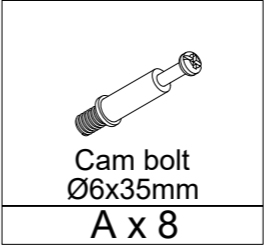
ASSEMBLY INSTRUCTIONS

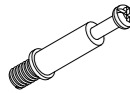

STEP 1 Insert cam bolts A into the settled holes on panels ①②③.

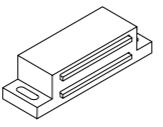
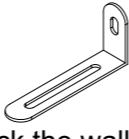
				
Cam bolt Ø6x35mm A x 14	Screw M3x14mm F x 4	Screw M4x14mm H x 2	Magnetic M x 2	Lock the wall iron Q x 2

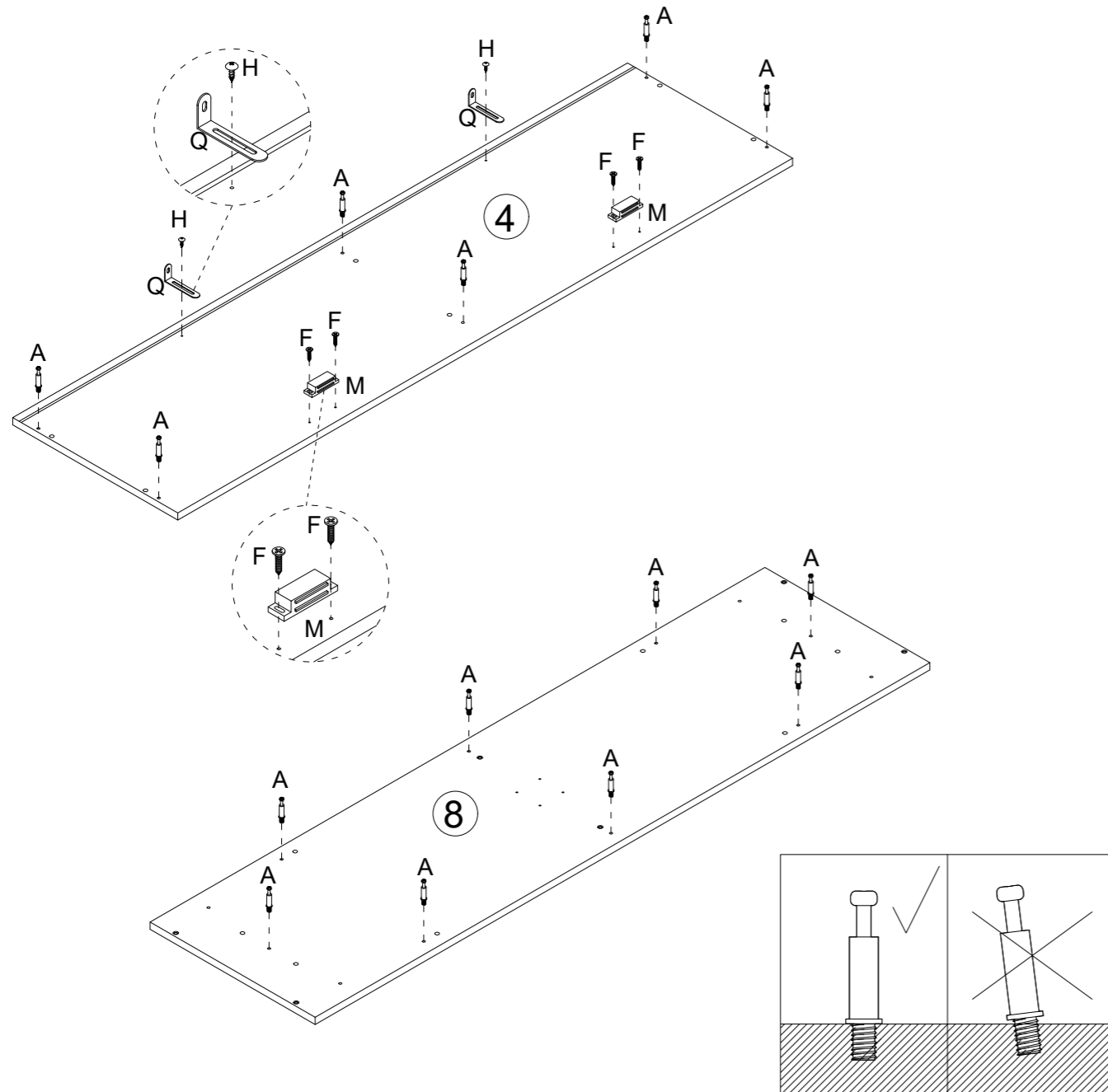

STEP 2 Insert cam bolts **A** into the settled holes on shelves ④ ⑧ .
 Insert the screws **H** into the settled holes on panel ④ through
 iron plate **Q**. Tighten the screws.
 Insert the screws **H** into the settled holes on panel ④ through
 magnetics **M**. Tighten the screws.

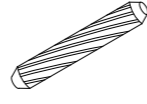
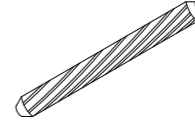
		
Cam lock Ø15x12mm B x 4	Wood dowel Ø8x30mm C x 2	Wood dowel Ø8x50mm R x 2

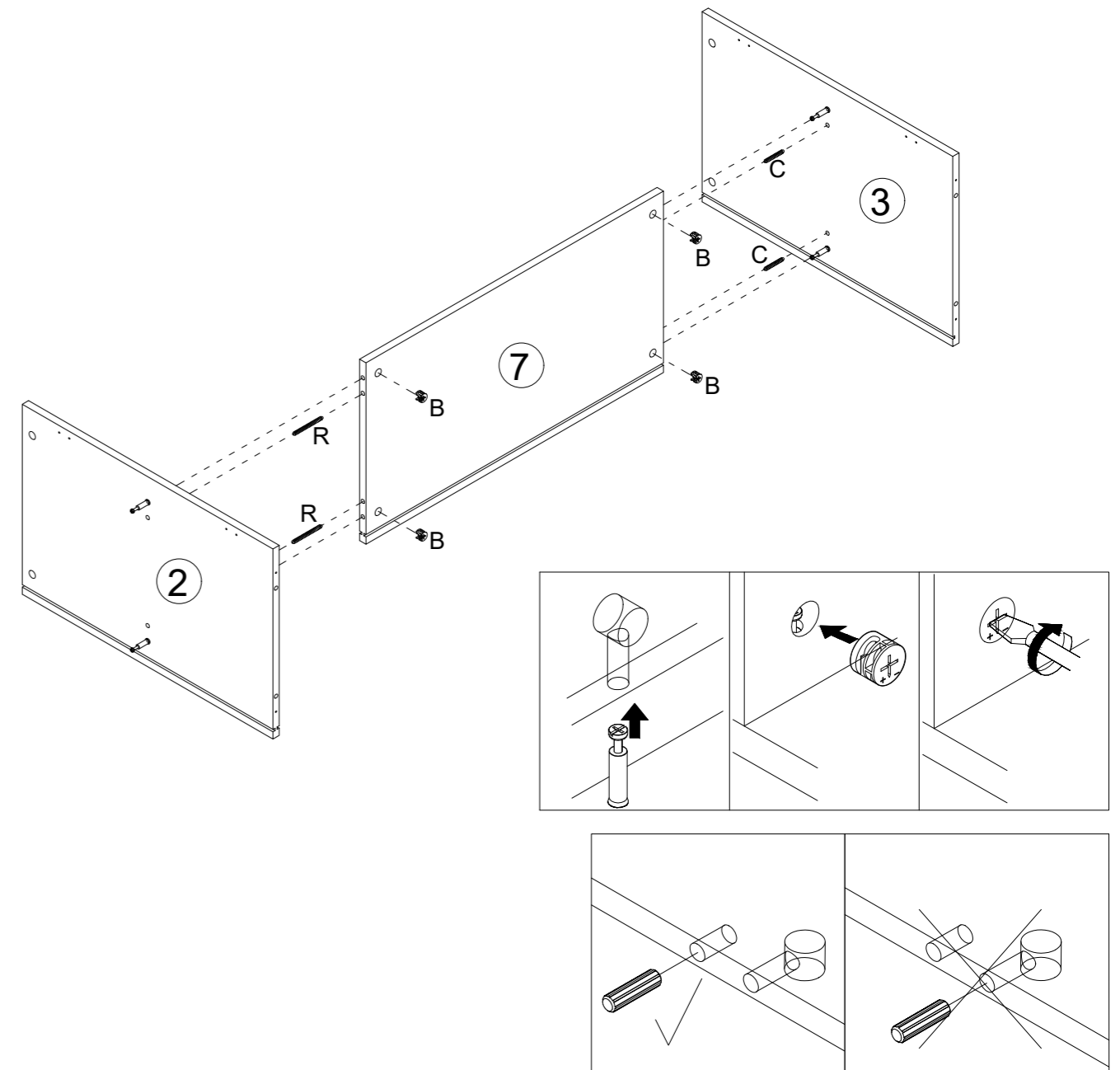

STEP 3 Do as the above instruction. Insert wood dowels **C.R** into the settled
 holes on shelf ⑦ .
 Put the cam locks **B** into the settled holes on shelf ⑦ accordingly.
 Align the other side of bolts **A** on panels ② ③ with the breach of cam
 locks **B**. Tighten the cam locks.

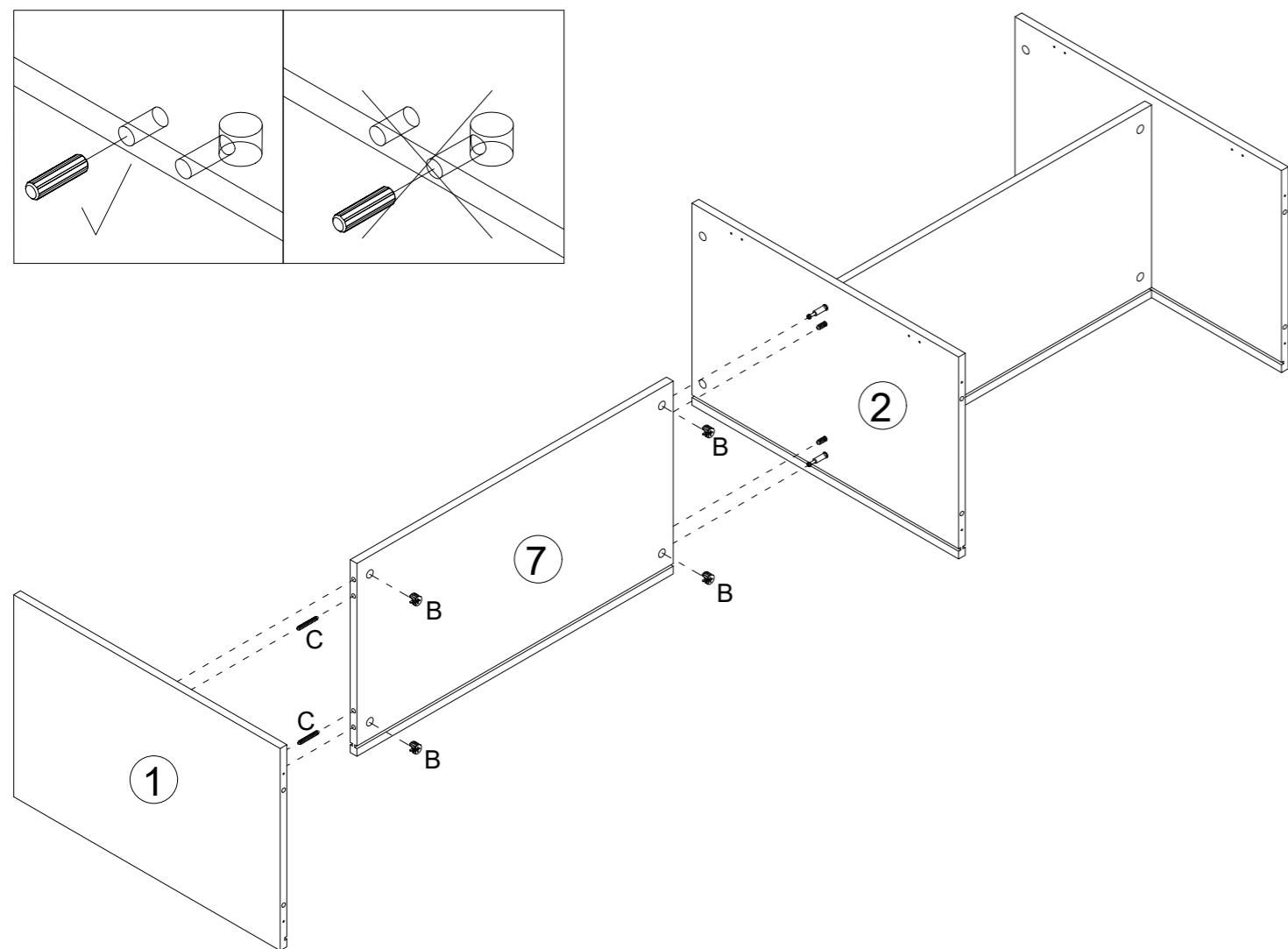
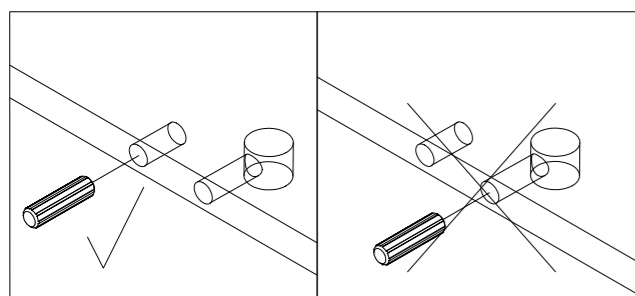
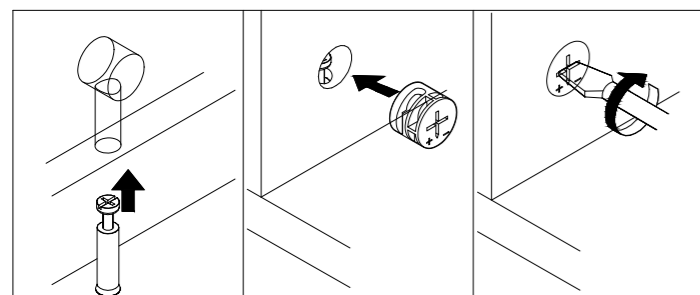
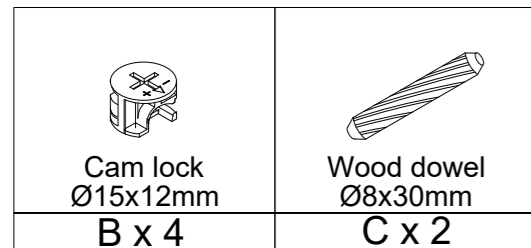

STEP 4 Put the cam locks B into the settled holes on shelf ⑦ accordingly. Align the other side of bolts A on panel ② with the breach of cam locks B. Tighten the cam locks. Insert wood dowels C into the settled holes on shelf ⑦. Put the cam locks B into the settled holes on shelf ⑦ accordingly. Align the other side of bolts A on panel ① with the breach of cam locks B. Tighten the cam locks.

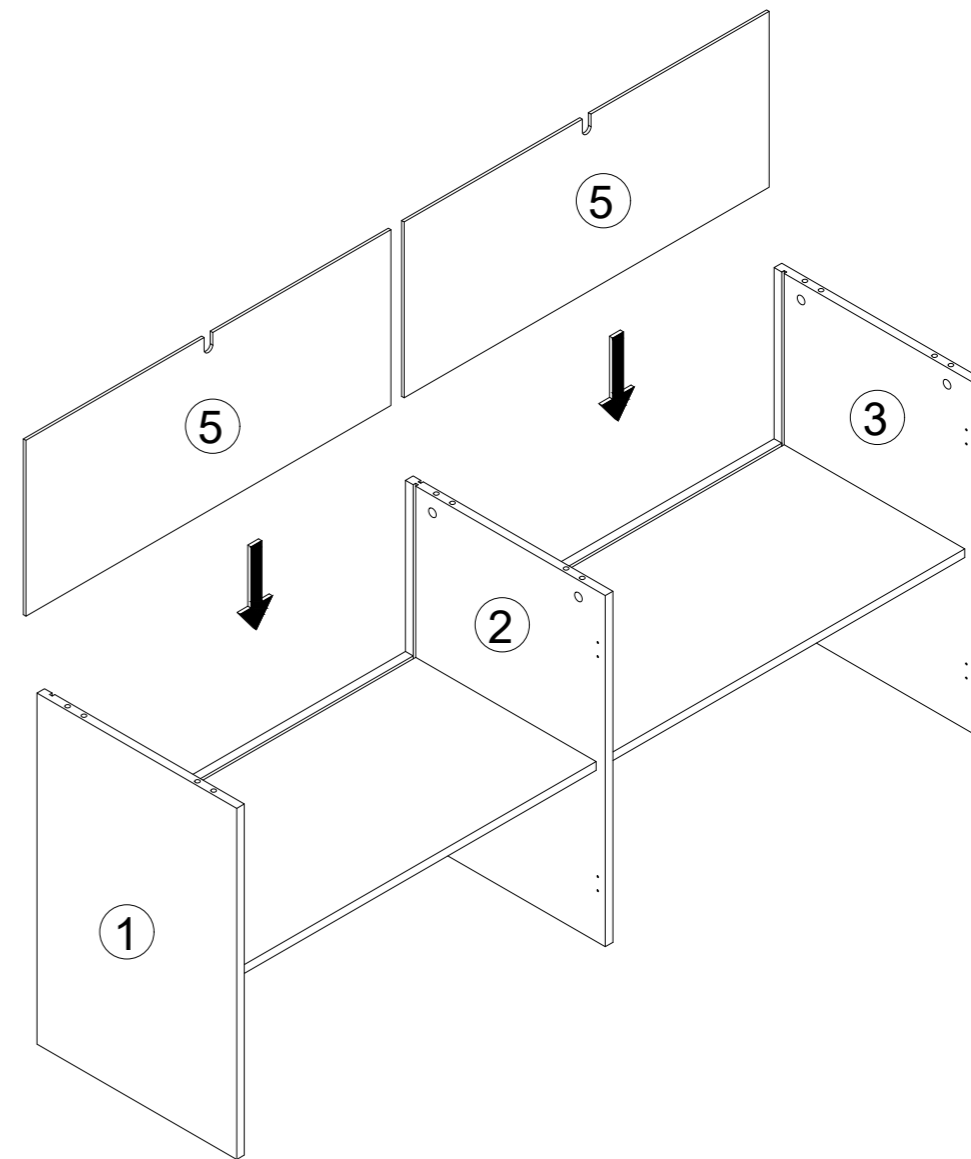

STEP 5 Do as the above instruction. Turn the assembled cabinet part upright. Insert rear panels ⑤ into the assembled part. Please embed the panel along with the wood trough.

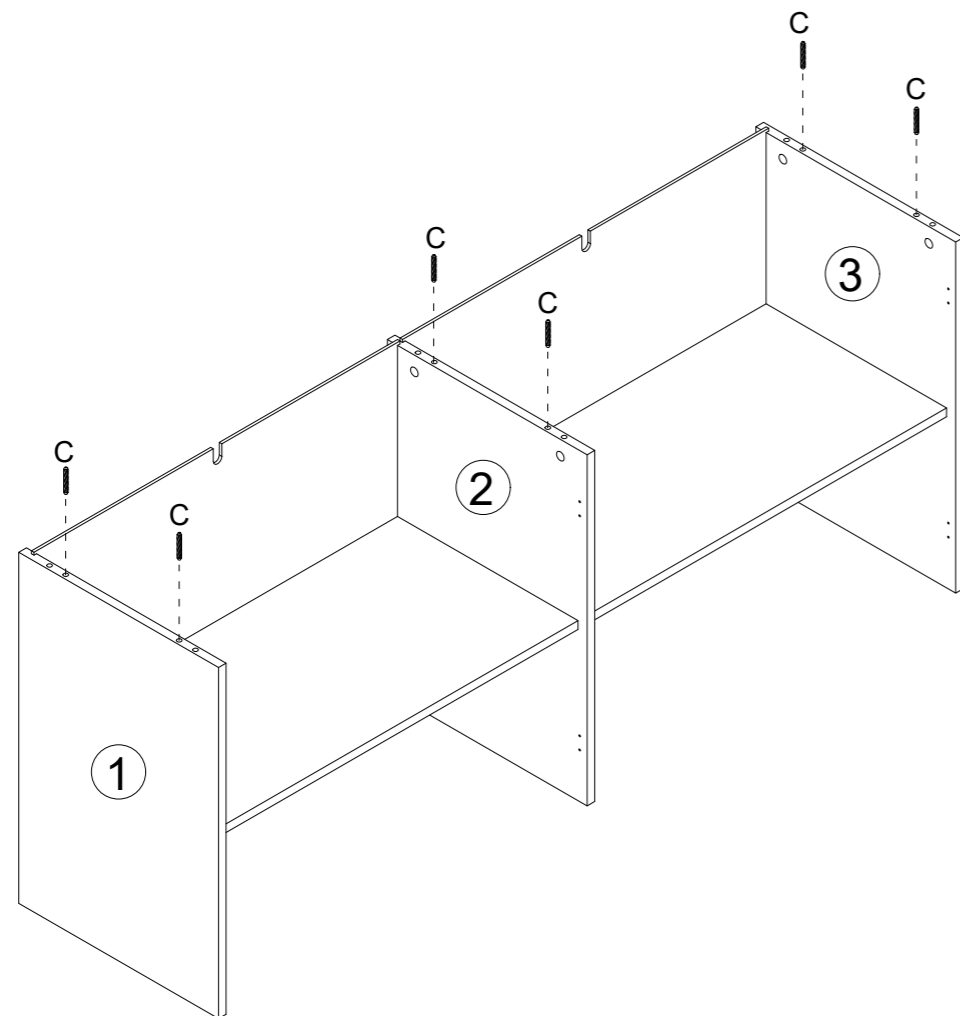
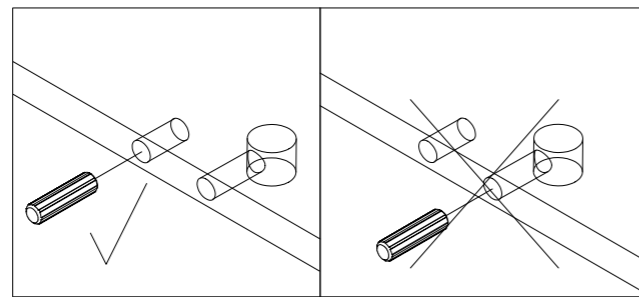
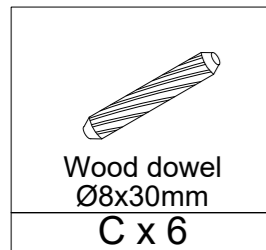

STEP 6 Do as the above instruction. Insert wood dowels C into the settled holes on panels ①②③.

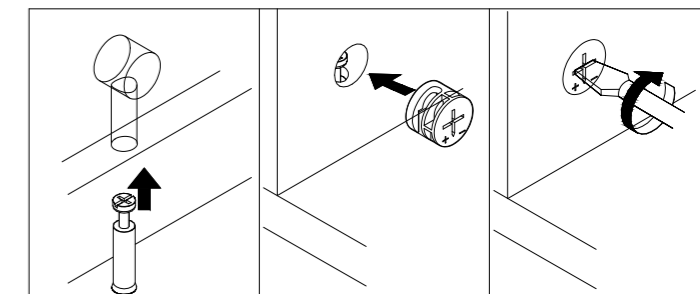
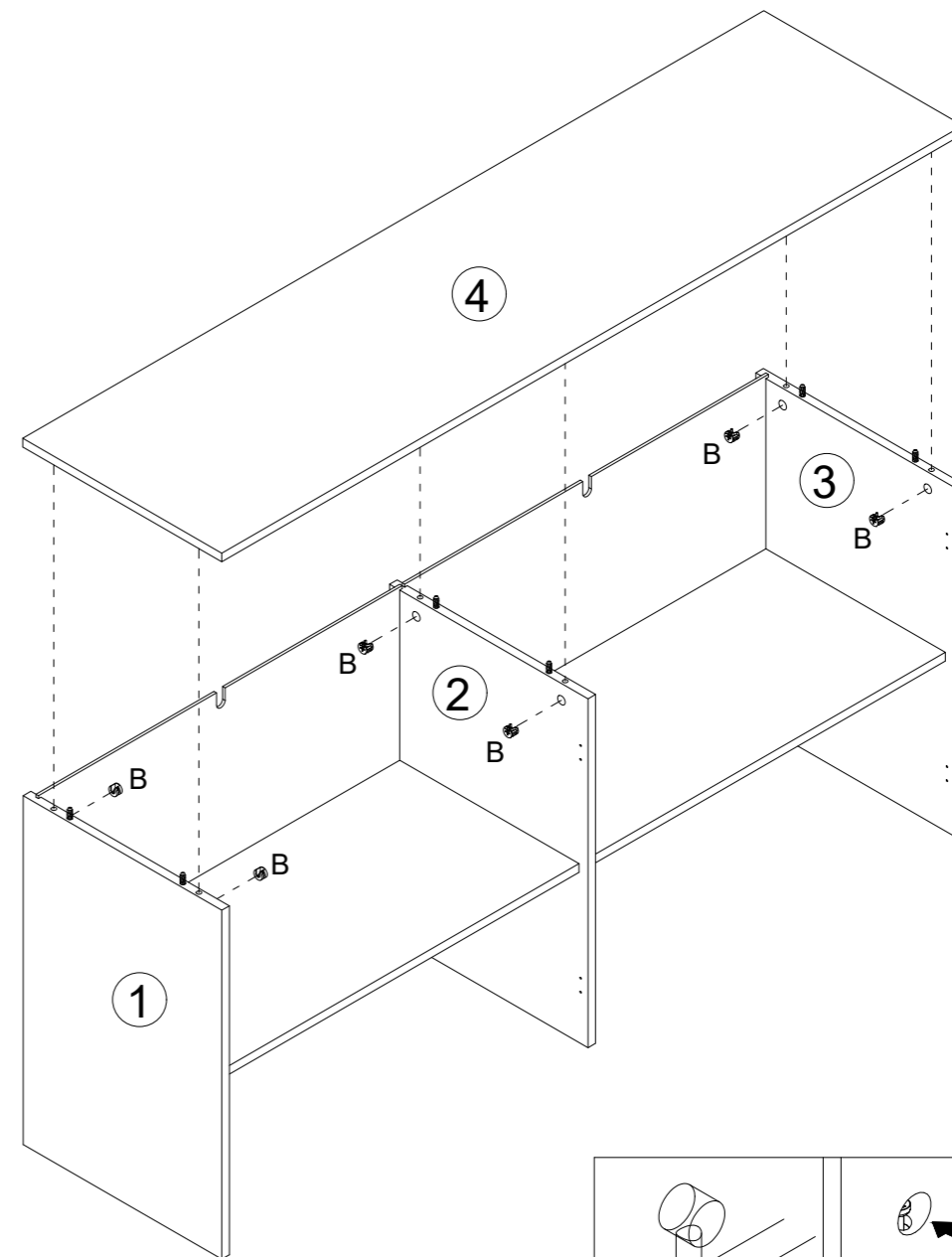
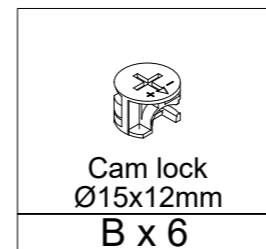

STEP 7 Put the cam locks B into the settled holes on panels ①②③ accordingly. Align the other side of bolts A on panel ④ with the breach of cam locks B. Tighten the cam locks.

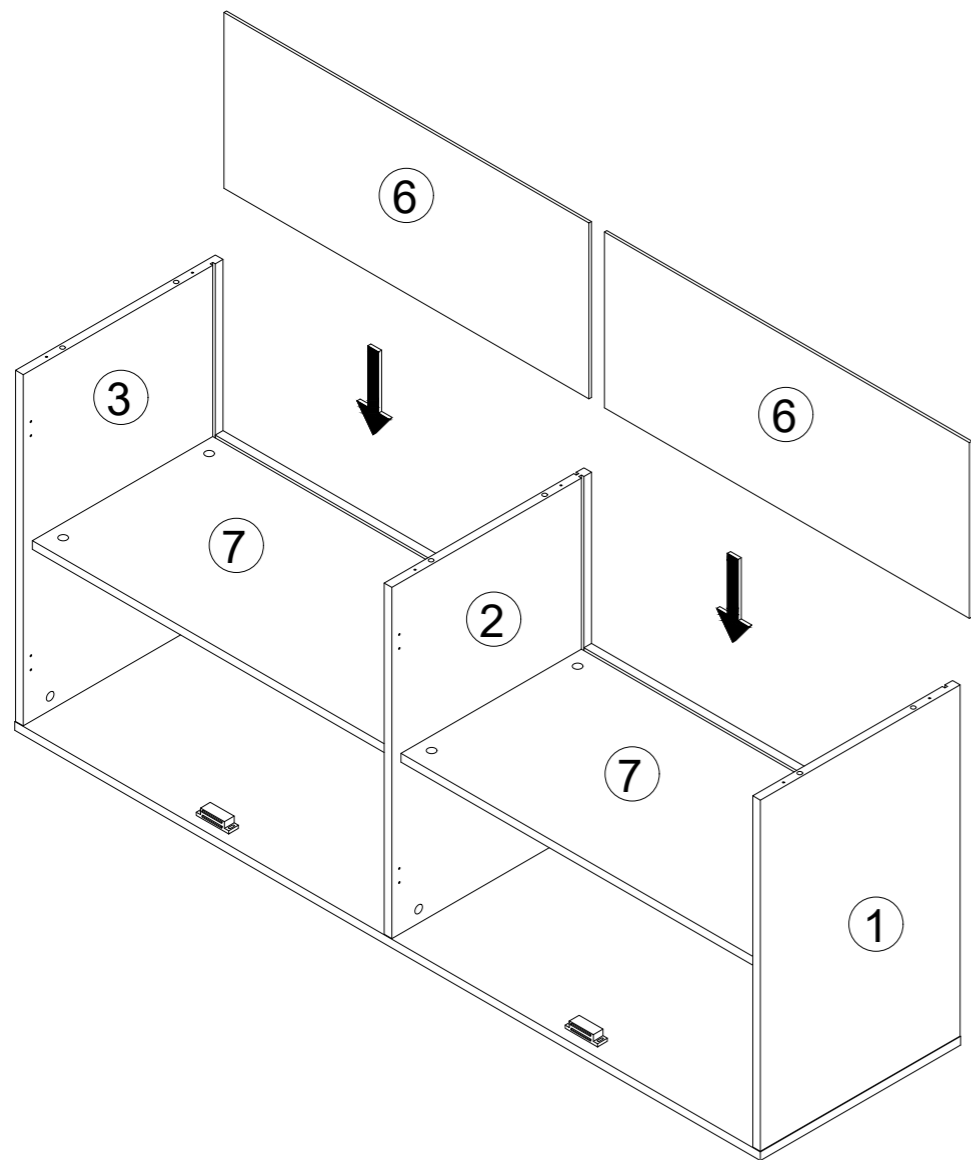

STEP 8 Do as the above instruction. Turn the assembled cabinet part upside down. Insert rear panel ⑥ into the assembled part. Please embed the panel along with the wood trough.

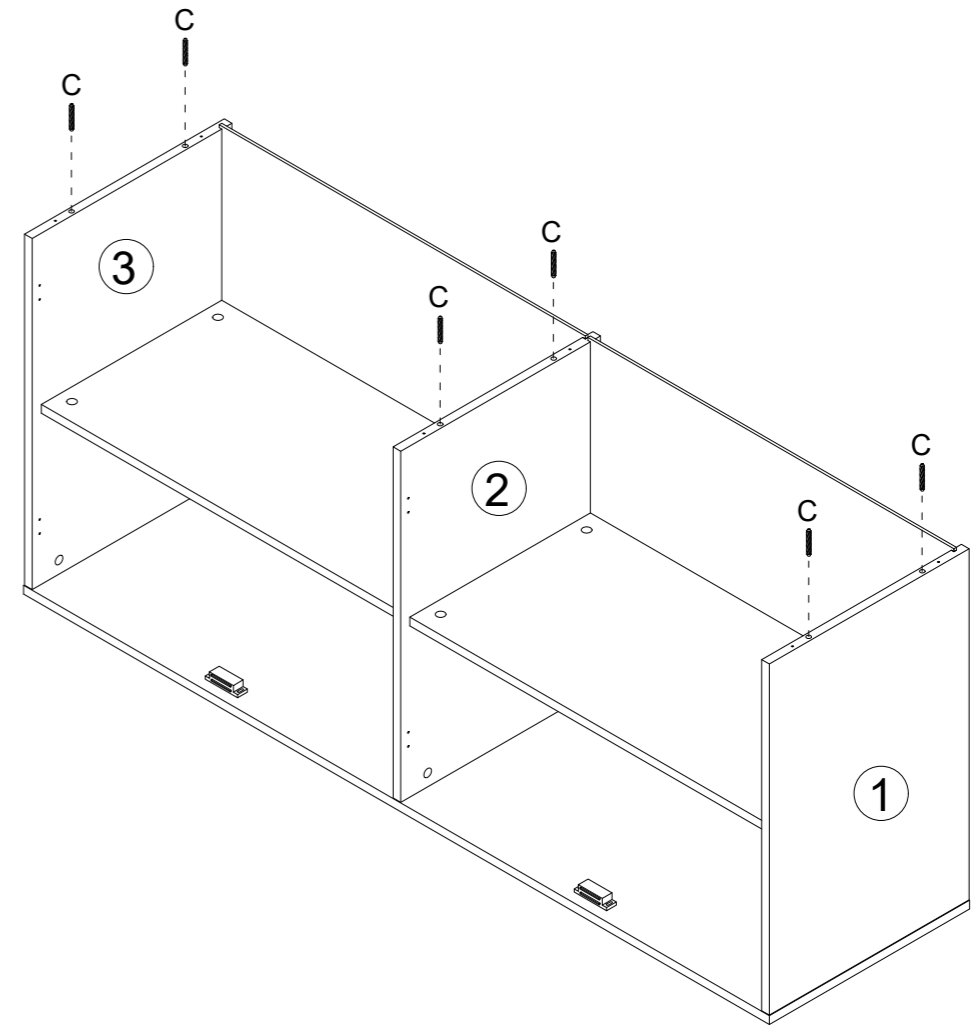
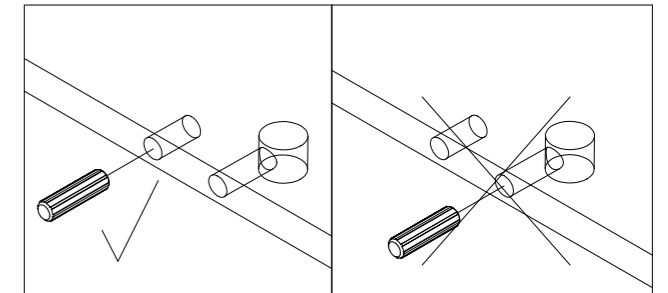
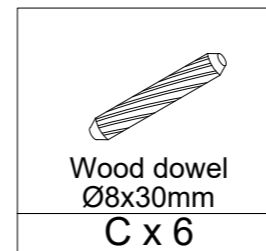

STEP 9 Do as the above instruction. Insert wood dowels C into the settled holes on panels ①②③.

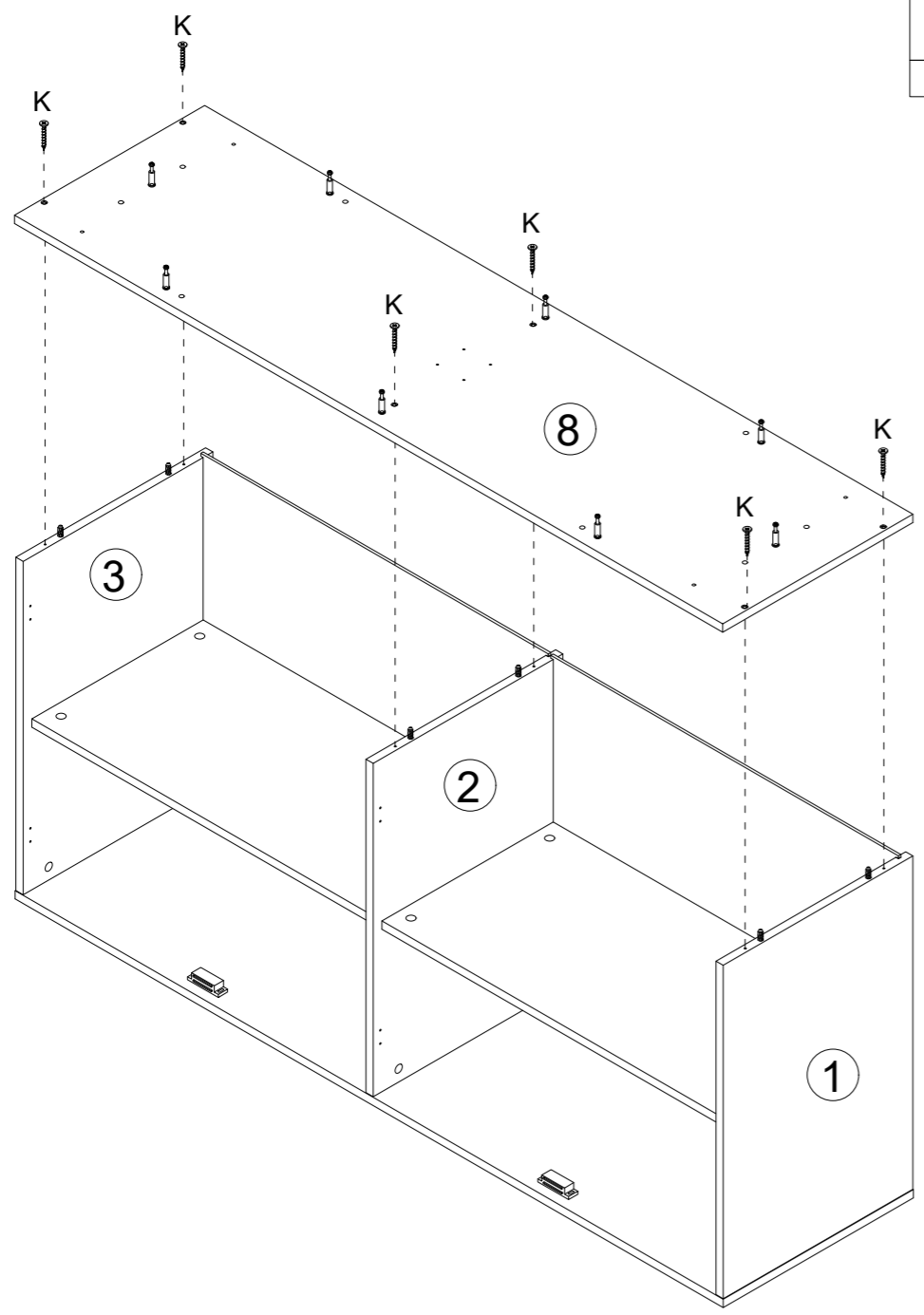

Screw
M4x35mm
K x 6

STEP 10 Put the shelf ⑧ onto the assembled part. Align the settled holes accordingly. Insert the screws K into the settled holes on board ⑧. Tighten the screws.

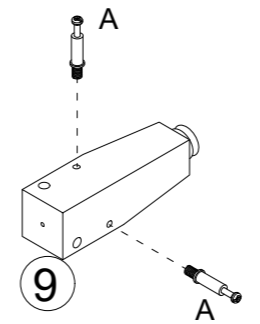
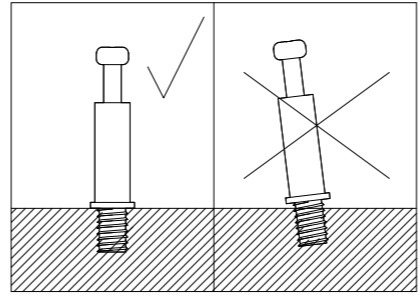

x4

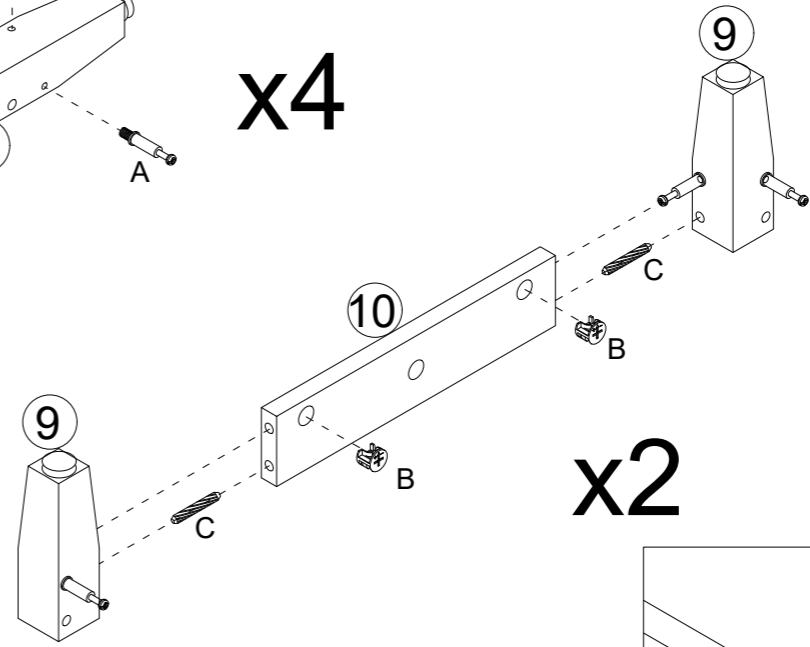

x2

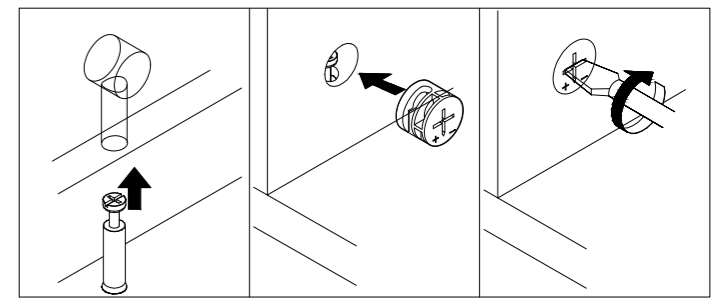
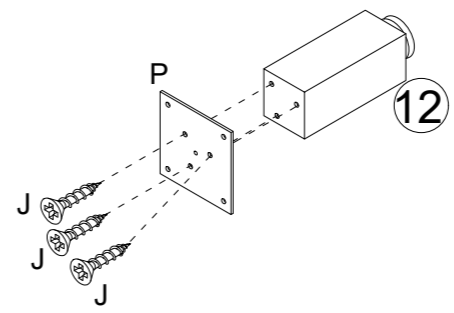
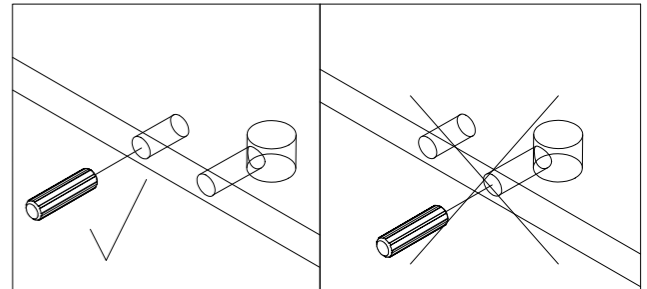

	 Cam bolt Ø6x35mm A x 8	 Cam lock Ø15x12mm B x 4
 Wood dowel Ø8x30mm C x 4	 Screw M4x25mm J x 3	 Iron sheets P x 1

STEP 11 Insert cam bolts A into the settled holes on feet ⑨. Insert wood dowels C into the settled holes on strips ⑩. Put the cam locks B into the settled holes on strips ⑩ accordingly. Align the other side of bolts A on panels ⑨ with the breach of B. Insert the screws J into the settled holes on foot ⑫ through iron sheet P. Tighten the screws.

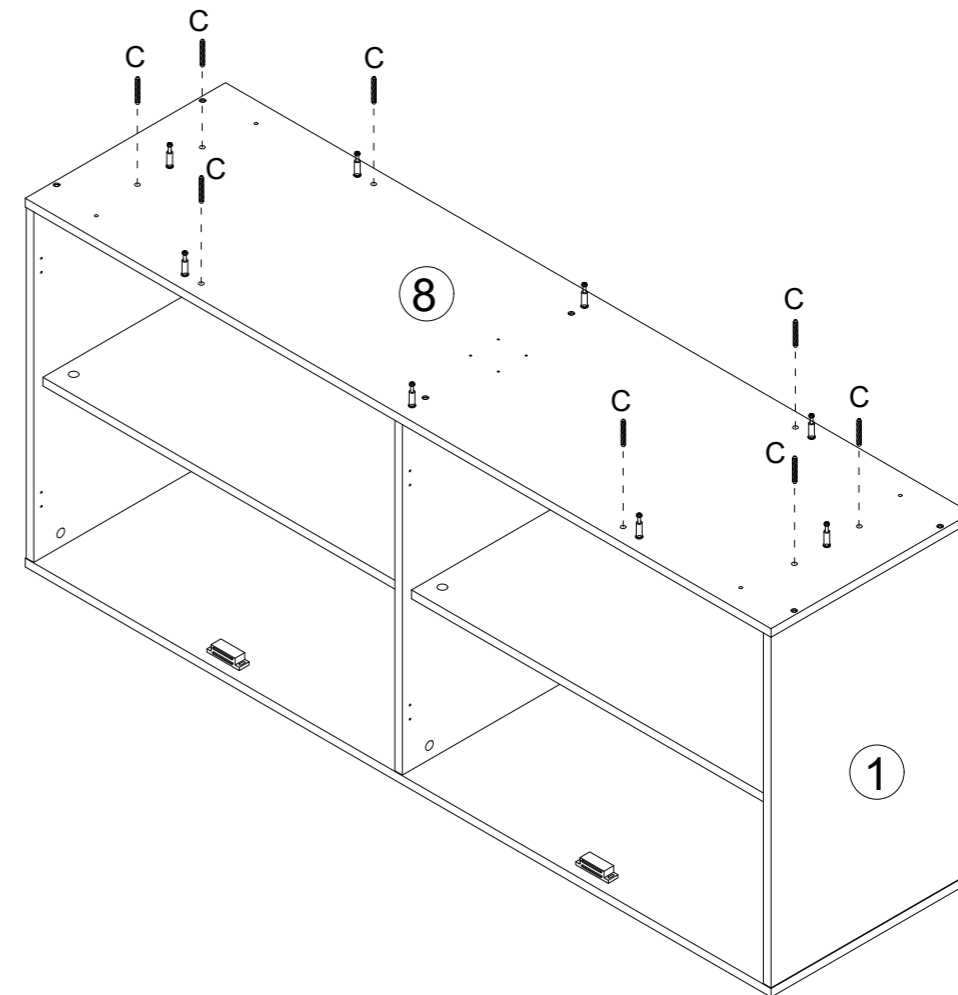
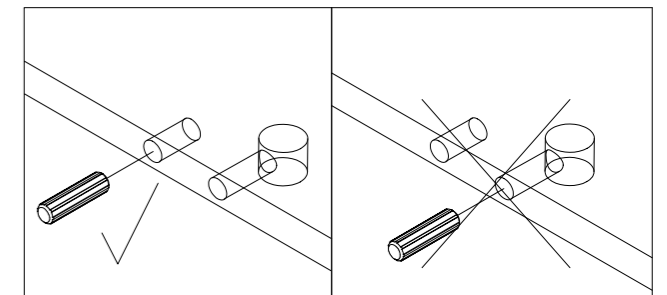
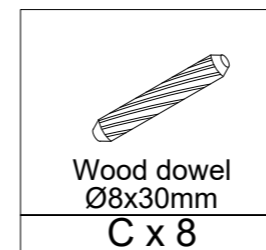
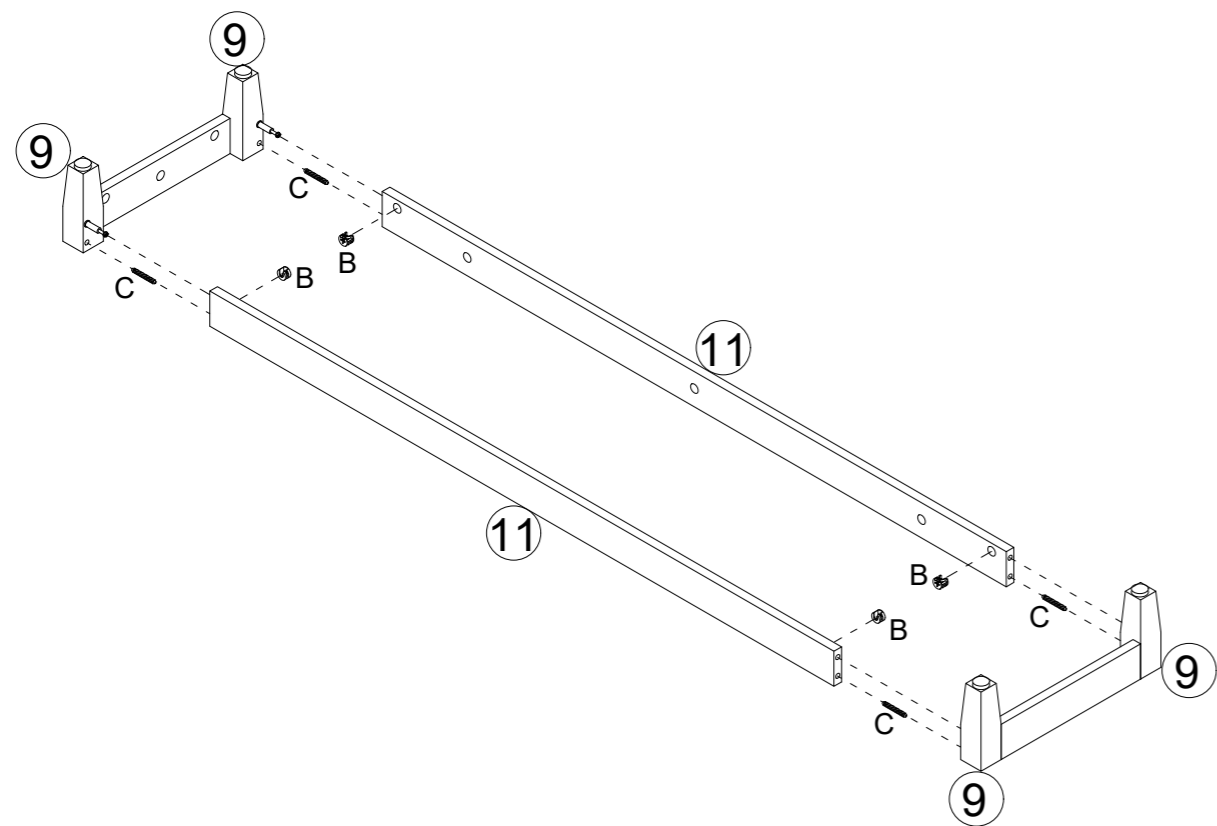
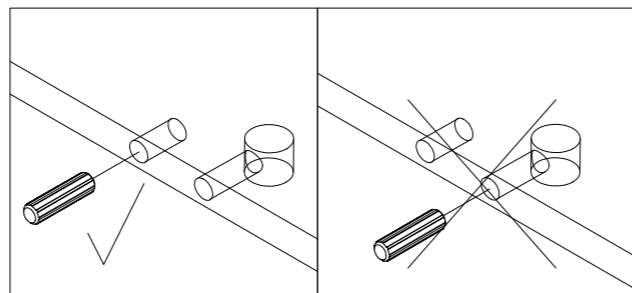
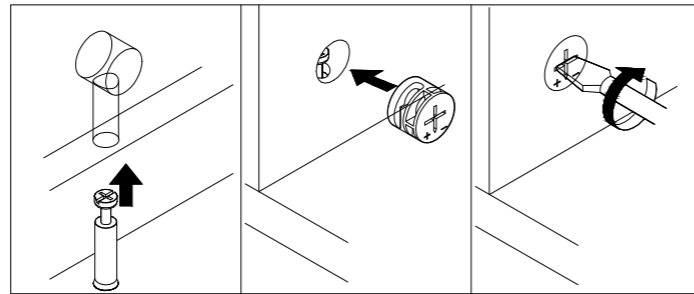
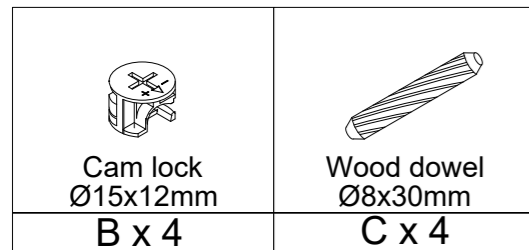

STEP 12 Do as the above instruction. Insert wood dowels C into the settled holes on strips ⑪ .
Put the cam locks B into the settled holes on strips ⑪ accordingly.
Align the other side of bolts A on feet ⑨ with the breach of cam locks B. Tighten the cam locks.

STEP 13 Do as the above instruction. Insert wood dowels C into the settled holes on shelf ⑧ .

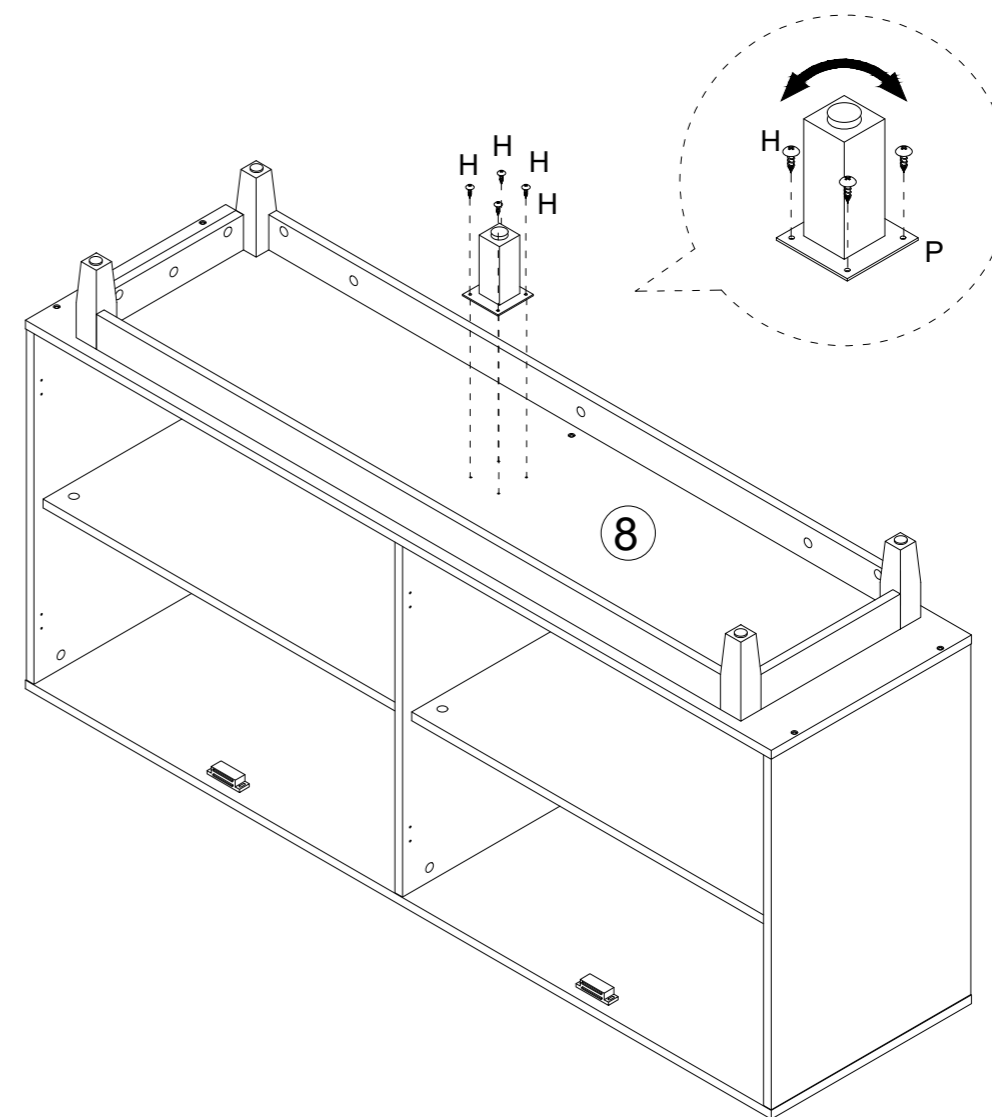
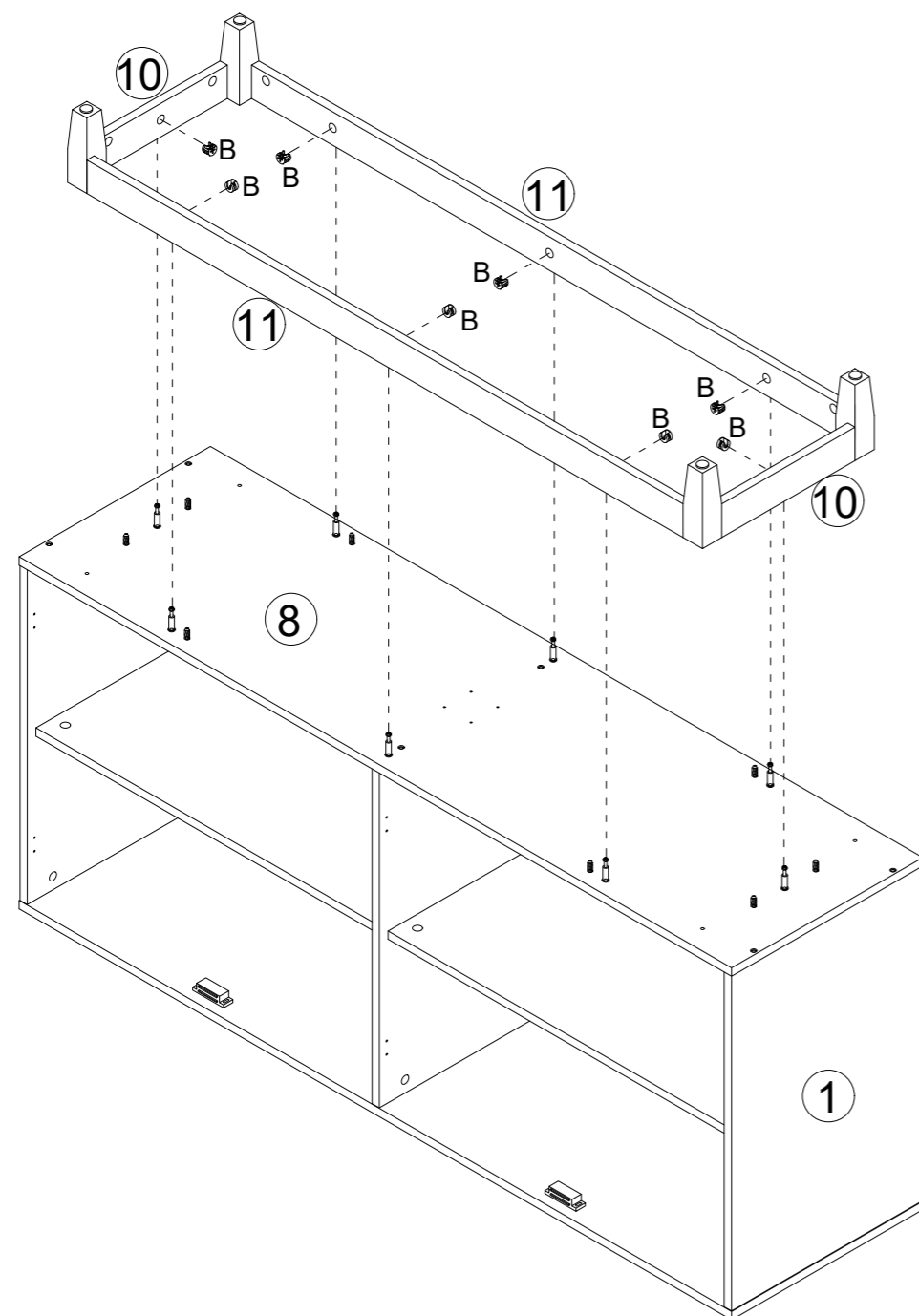
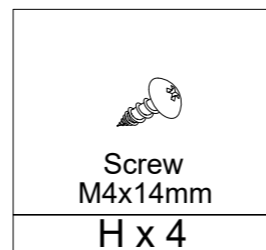
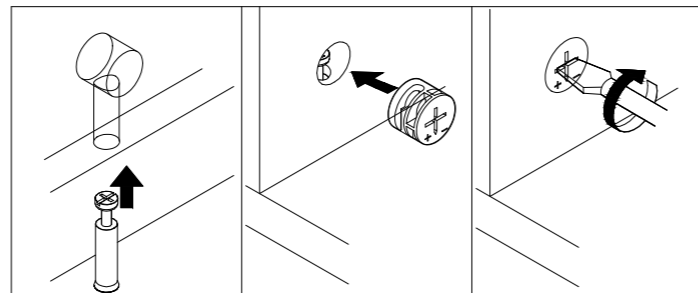
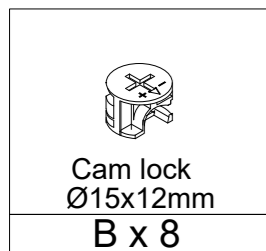

STEP 14 Put the cam locks B into the settled holes on strips ⑩ ⑪ accordingly. Align the other side of bolts A on shelf ⑧ with the breach of cam locks B. Tighten the cam locks.

STEP 15 Insert the screws H into the settled holes on shelf ⑧ through iron sheet P. Tighten the screws.

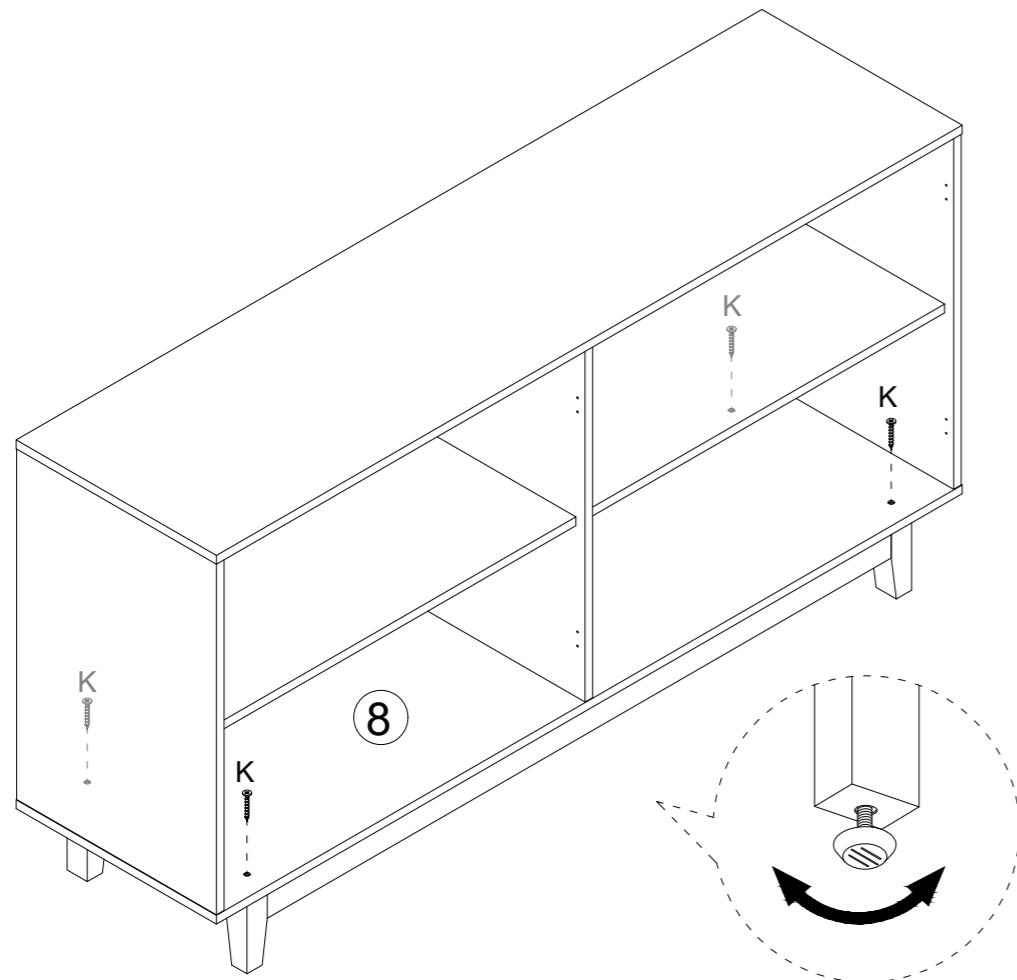
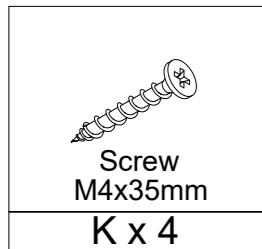

Attention:
If the cabinet is uneven, please
adjust the adjustable leveler to
keep the cabinet balanced.

STEP 16 Insert the screws H into the settled holes on shelf (8).
Tighten the screws.

 Screw M3.5x12mm G x 24	 Screw M4x18mm I x 8	 Handle D x 4
 Hinge E x 8	 Screw M3x14mm F x 4	 Magnetic iron sheet N x 4

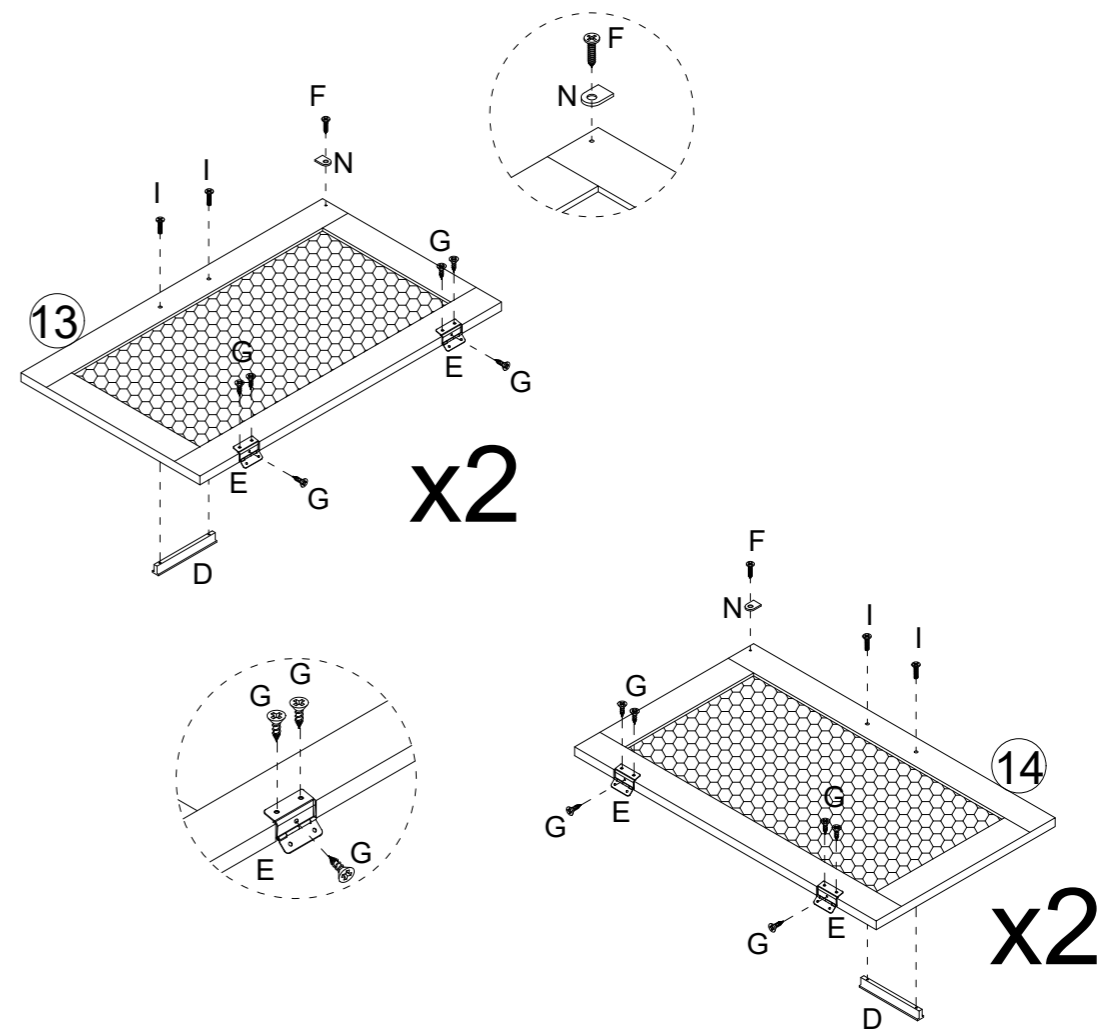

STEP 17 Install the hinges E onto the doors (13) (14) with screws G.
Install the handles D onto the doors (13) (14) with screws I.
Install the magnetic iron sheets N onto the doors (13) (14) with screws F.

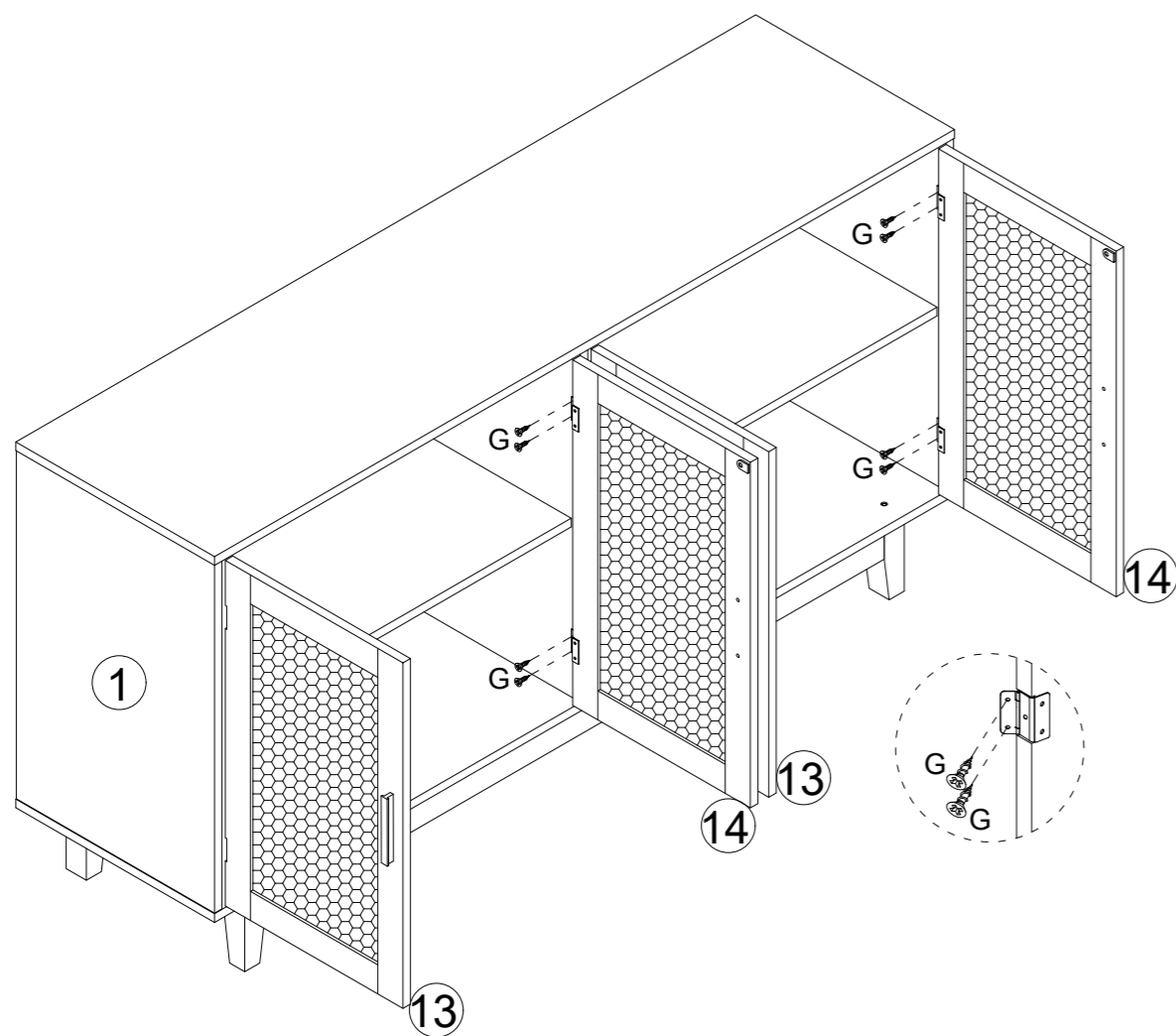
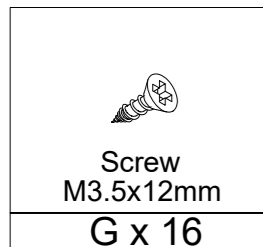

STEP 18 Install the doors ⑬ onto the apanels ① ② with screws G. Install the doors ⑭ onto the apanels ② ③ with screws G.

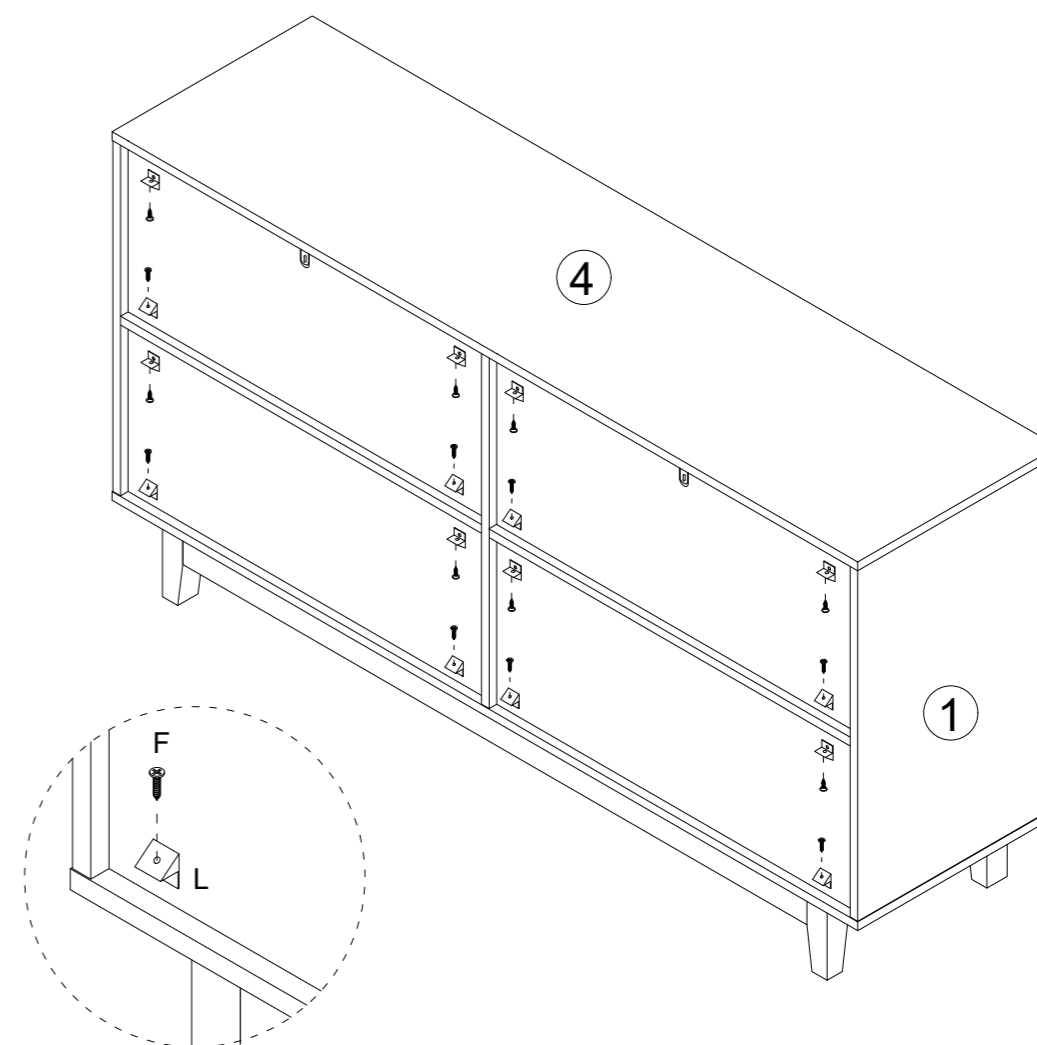
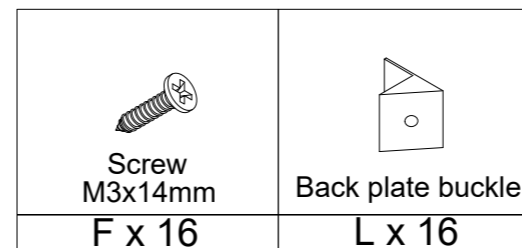

STEP 19 Do as the above instruction. Adjust the gaps between the panels. Fasten the back plate buckles L on the corners of the cabinet back accordingly. Tighten with screws F.

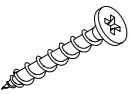
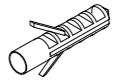
	
Screw M4x35mm	Wall plug Ø6x30mm
K x 2	O x 2

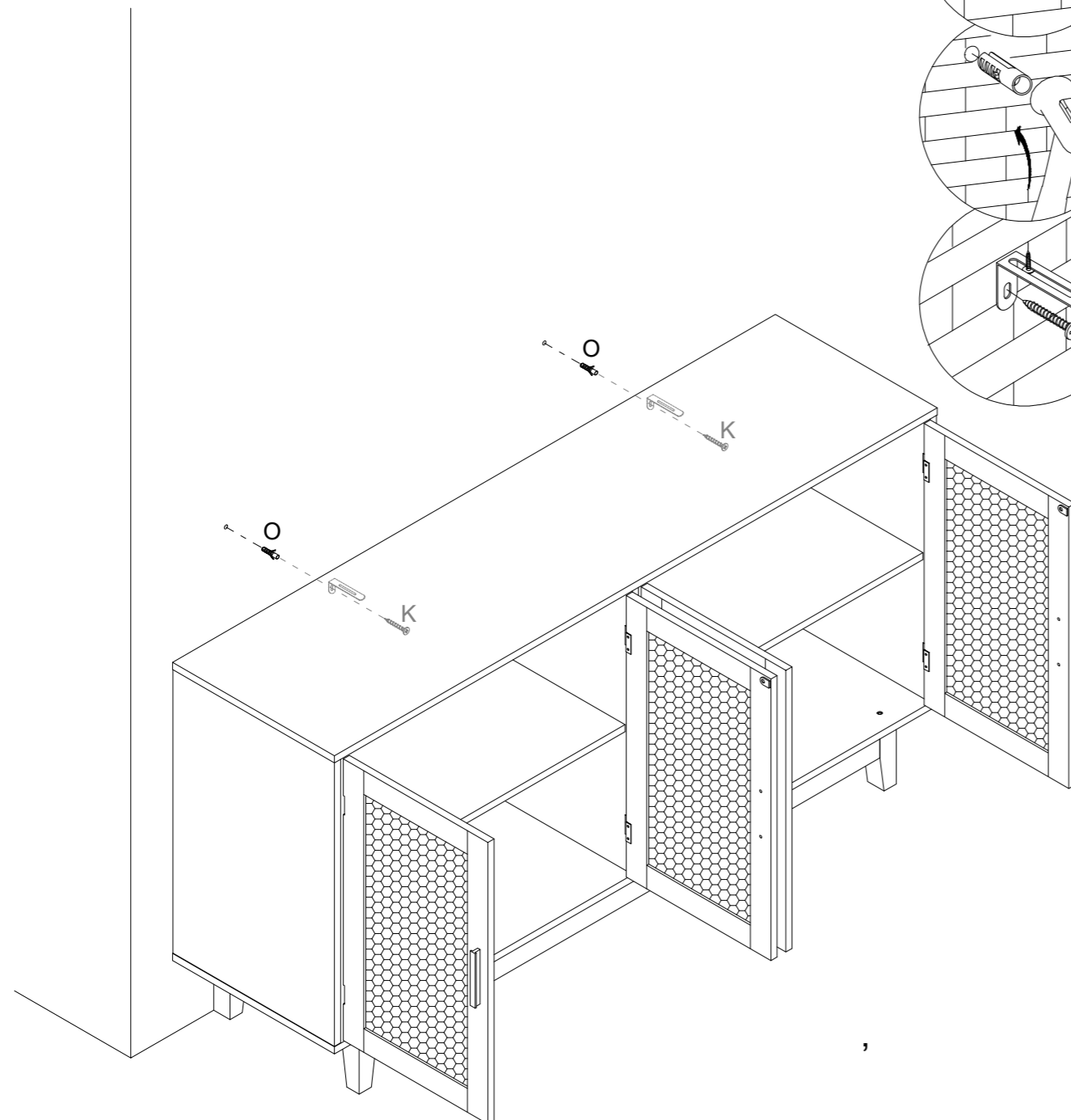
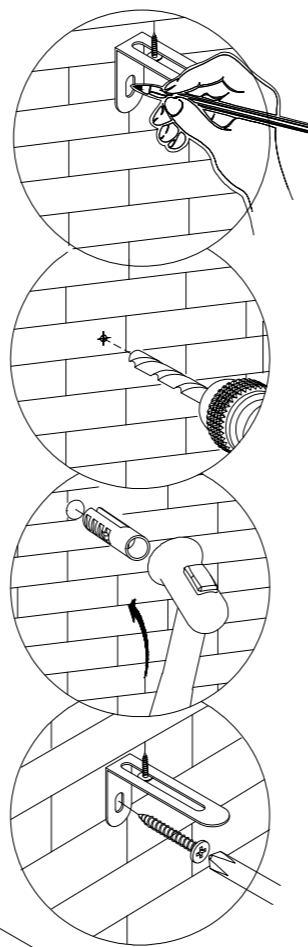

STEP 20 Move the assembled cabinet part against the wall.
 Remark the position of iron plates **Q** , drill the holes accordingly.
 in the wall, with the depth of at least 30mm.
 Insert the wall plugs **O** into the wall with hammer.
 Connect the iron plate **Q** to the wall with screws **K** by going
 through wall plug **O** .

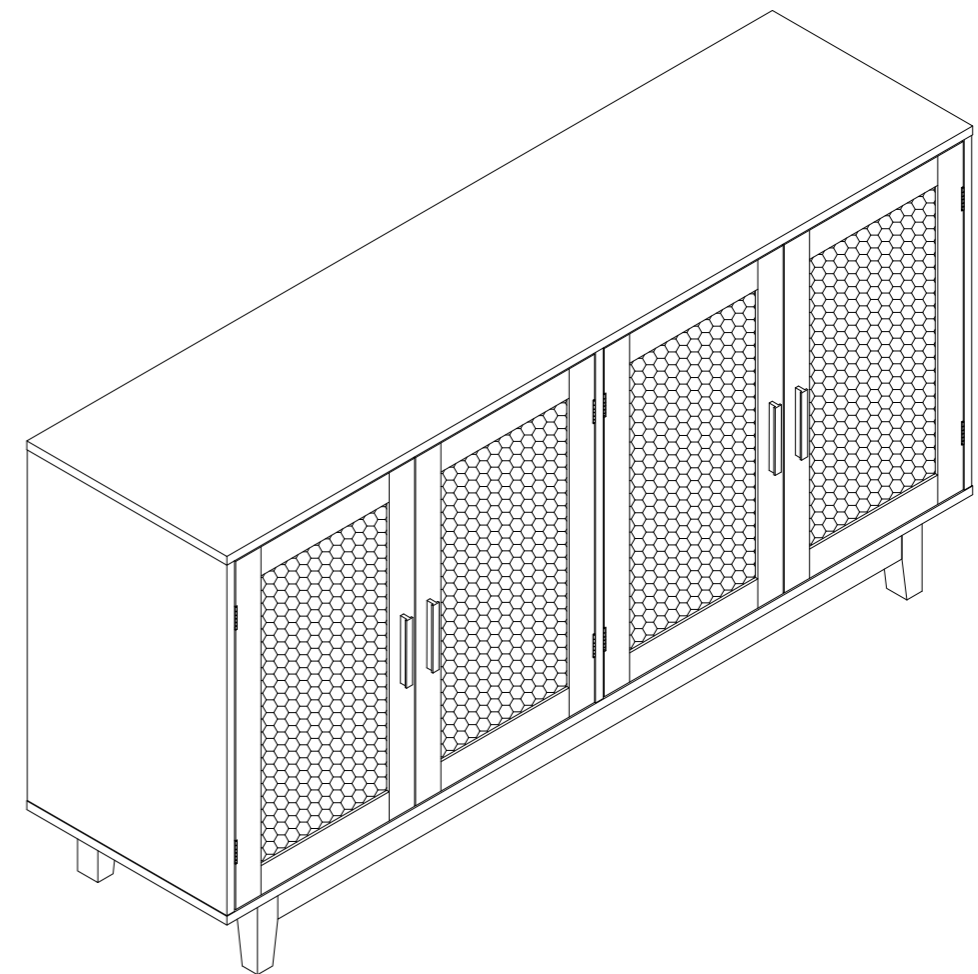

STEP 21 Assembly is completed.