

Assembly Instructions

Note: Please help to read my instruction before you ready to assemble.

SOFA

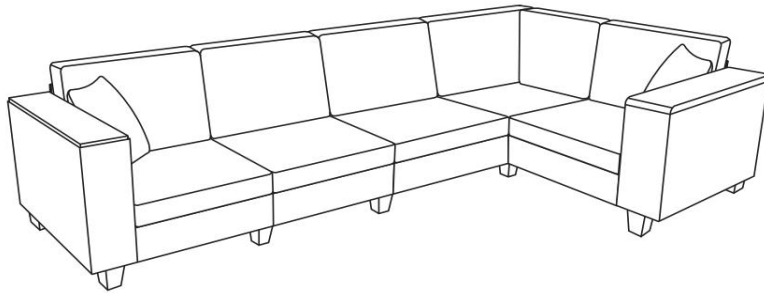





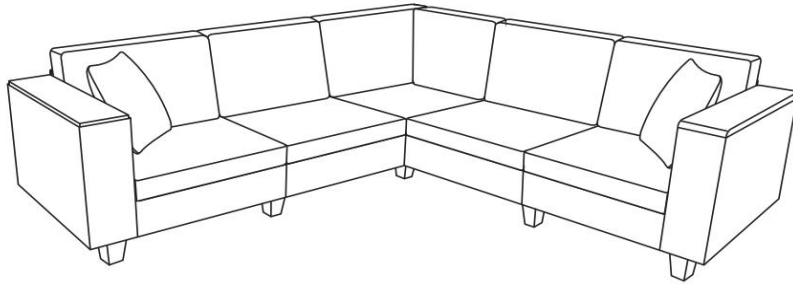

Sectional 1



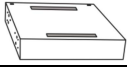
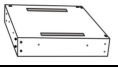
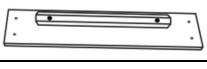
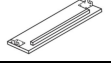
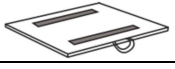
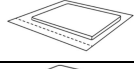







Sectional 2

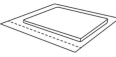

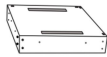
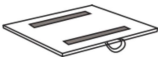
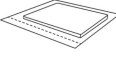









Part List





Label	Picture	Description	QTY (PCS)
A		Backrest	6
B		Left Armrest	1
C		Right Armrest	1
D		Seat Frame	2
E		Corner Seat Frame	1
F		Back Rail	2
G		Front Rail	2
H		Seat Panel	2
I		Seat Cushion Package	5
J		Seat Cushion after decompression from(I)	5
K		Back Cushion	5
L		Corner Back Cushion	1
M		Pillow	2
N		Leg	12

9690A-A Part List			
A		Backrest	4
D		Seat Frame	2
I		Seat Cushion Package	3
9690A-B Part List			
A		Backrest	2
E		Corner Seat Frame	1
H		Seat Panel	2
I		Seat Cushion Package	2
K		Back Cushion	1
L		Corner Back Cushion	1
N		Leg	12

9690A-B Hardware

①		Wood dowel	8
②		"L" Iron Connect Plate	4
③		Plastic Washer	12
④		Bolt (M8*60mm)	4
⑤		Allen Wrench (S5)	1
⑥		Bolt (M8*25mm)	12
⑦		Bolt (M8*40mm)	28
⑧		Flat Washer	42
⑨		Spring Washer	40
⑩		Ratchet Wrench	1
⑪		Nut	2
⑫		Spanner	1

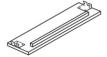
9690A-C Part List

B		Left Armrest	1
C		Right Armrest	1
F		Back Rail	2
G		Front Rail	2
K		Back Cushion	4
M		Pillow	2

NOTICE:

- Please read the instruction from cover to cover in detail.Thanks.
- Installed by at least two adults
- To avoid damaging your furniture , Please don't assemble on flooring or carpet.
- Please assemble on a clean non-marring surface, example for packing foam.
- Saving all packaging until have finished.

Assembly Steps:

OVERVIEW

Sectional 1

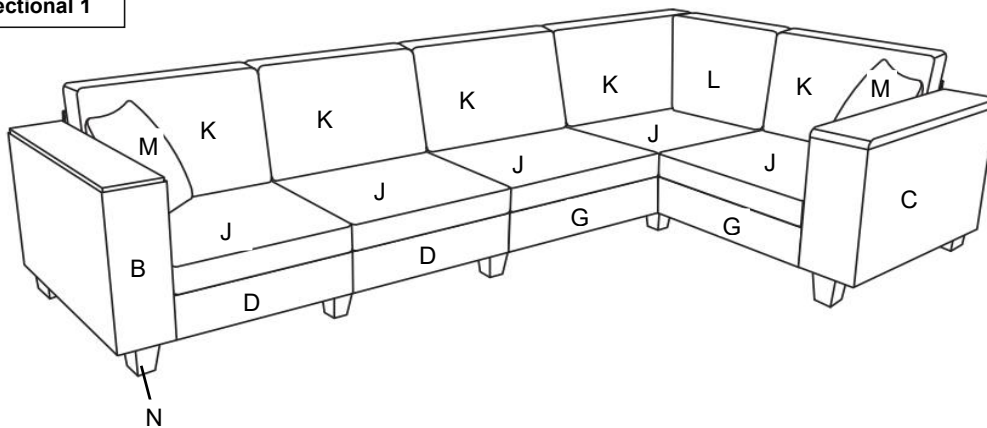

Sectional 2

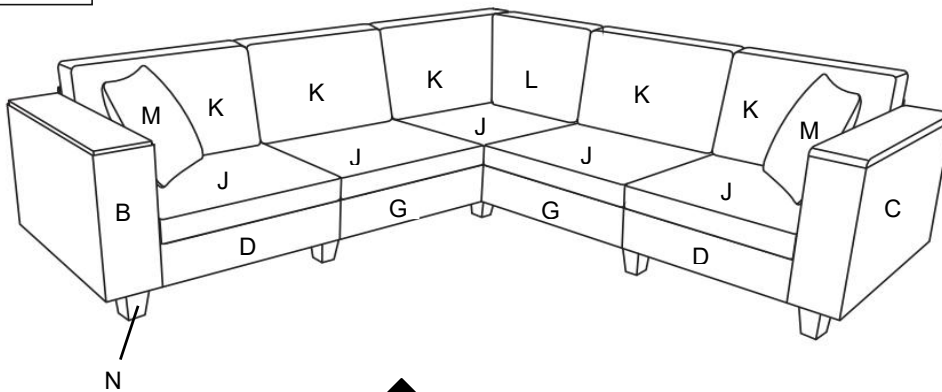

FRONT FACING

This SOFA has multiple parts and may require up to 45 minutes to assemble. To give you an overview of the SOFA parts, the above picture is to help you put the various parts into perspective. Please read through the instructions below to familiarise yourself with the parts and steps before assembly.
Note: It is recommended that you have an adult partner to assist during the entire assembly process.

Step 1

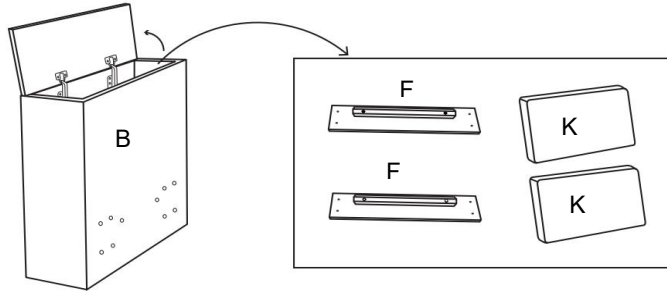

Remove Two Back Rails (F) and two Back Cushions(K) from Left Armrest(B).

Step 2

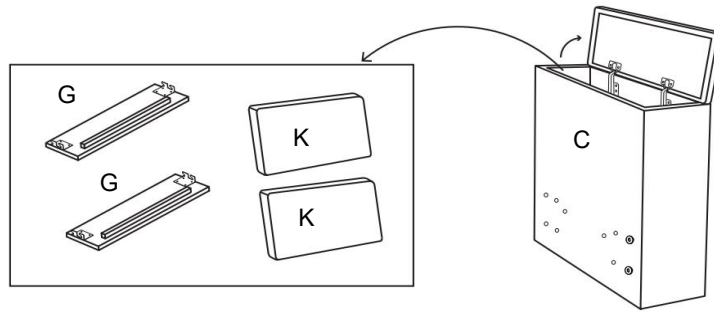

Remove Two Front Rails (G) and two Back Cushions(K) from Right Armrest(C).

Step 3

Sectional 1 pls X 2

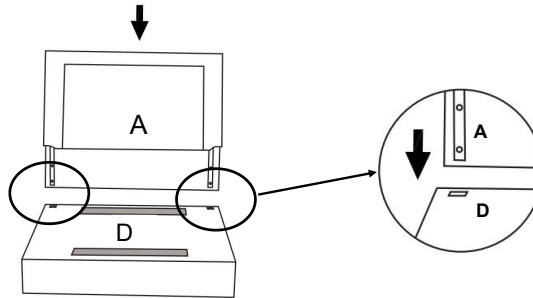

Sectional 2 pls X 2

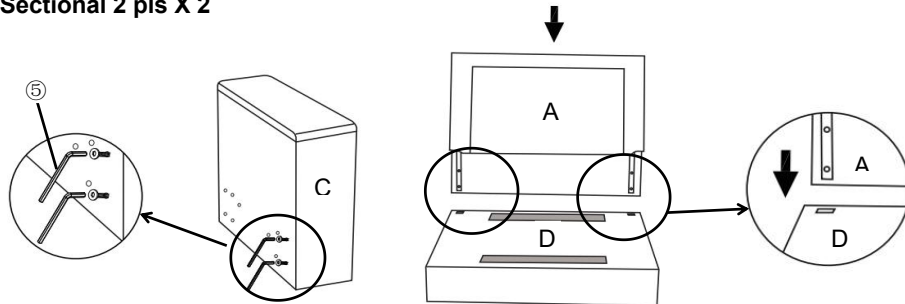

Sectional 1 , please repeat this assembly step 2 times,Insert the Backrest(A) into the Seat Frame(D).
Sectional 2 ,Please unscrew the two Bolts with Allen Wrench(Ⓢ) from Right Armrest(C) first.Then repeat this assembly step 2 times,Insert the Backrest(A) into the Seat Frame(D).

Step 4

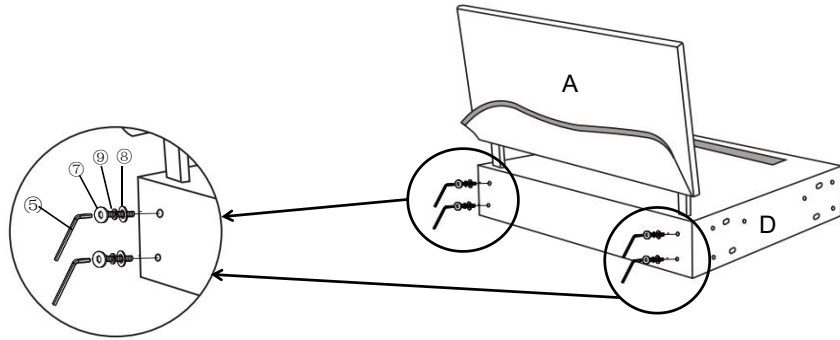

Sectional 1 pls X 2

Please repeat this assembly step 2 times, Then using Bolt(7) Sping Washer (9) Flat Washer(8) with Allen Wrench (5), turning clockwise until tight as shown.

Step 5

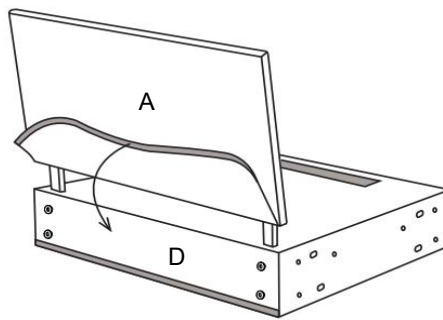

Sectional 1 pls X 2

Please repeat this assembly step 2 times, Attach the magic tape to the back of the Seat Frame(D).

Step 6

Sectional 1

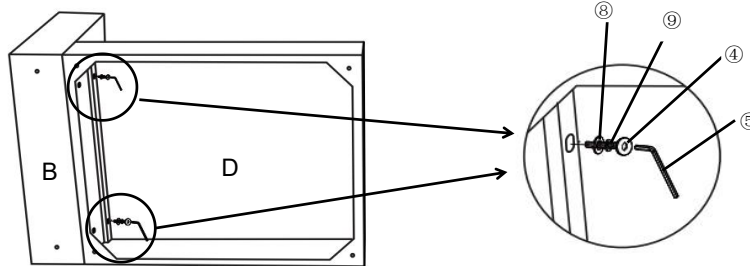

Sectional 2

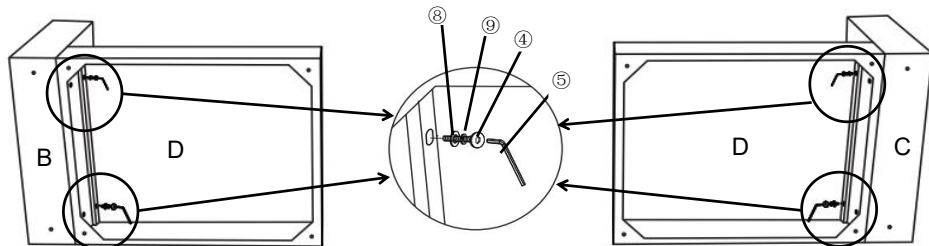

Sectional 1 , Install the Left Armrest(B) to Seat Frame(D) by using Bolt(4) Sping Washer (9) Flat Washer(8) with Allen Wrench(5) , and turning clockwise until tight as shown.

Sectional 2 , Install the Left Armrest(B) to Seat Frame(D) , Right Armrest(C) to Seat Frame(D) by using Bolt(4) Sping Washer (9) Flat Washer(8) with Allen Wrench(5) , and turning clockwise until tight as shown.

Step 7

Sectional 1

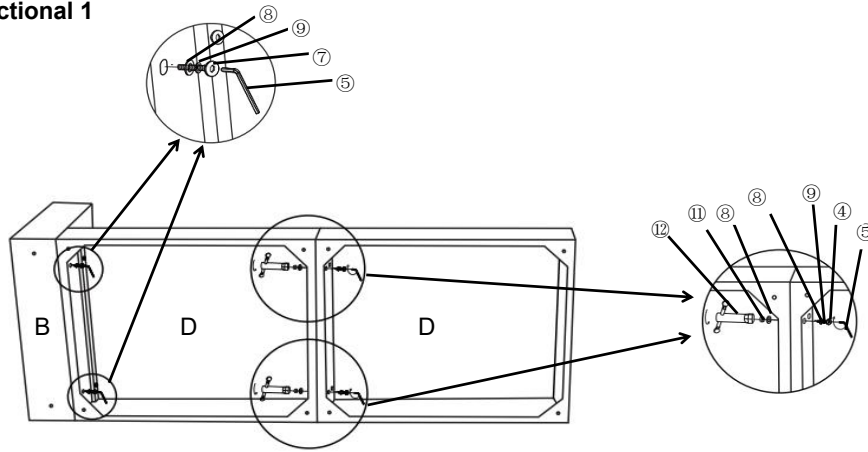

Sectional 2

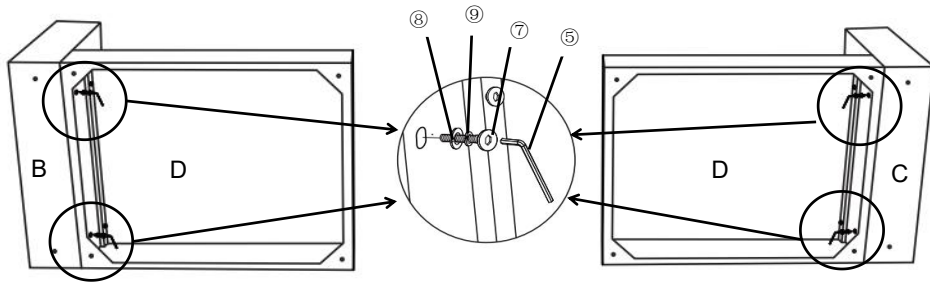

Sectional 1 , Install the Left Armrest(B) to Seat Frame(D) by using Bolt(7) Sping Washer (9)Flat Washer(8) with Allen Wrench(5) ,Install two Seat Frame(D) by using Bolt(7) Sping Washer (9)Flat Washer(8) with Allen Wrench(5) ,Nut (11) with Spanner(12), turning clockwise until tight as shown.
Sectional 2 , Install the Left Armrest(B) to Seat Frame(D), Right Armrest(C) to Seat Frame(D) by using Bolt(7) Sping Washer (9)Flat Washer(8) with Allen Wrench(5) , and turning clockwise until tight as shown.

Step 8

Sectional 1

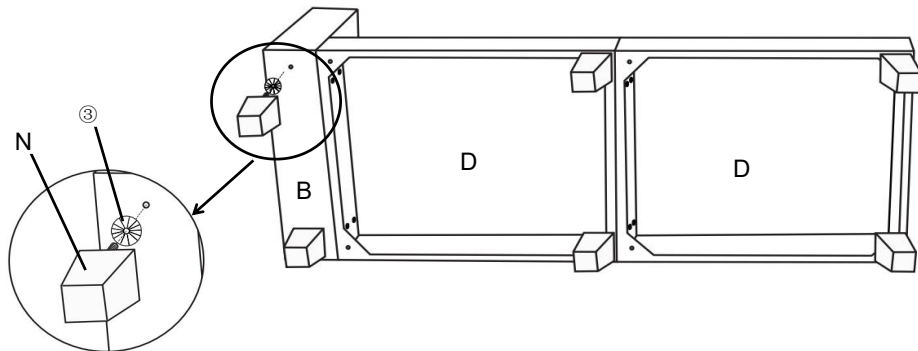

Sectional 2

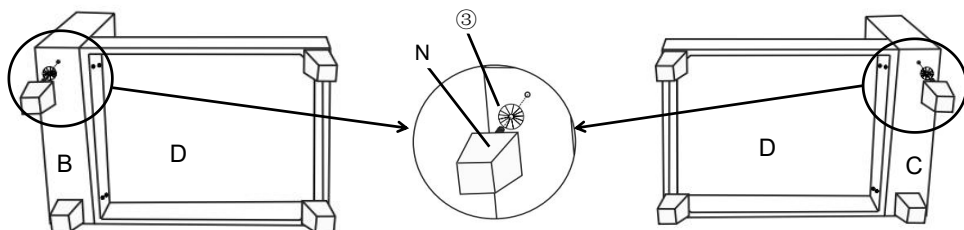

Sectional 1 ,Install the Leg(N) at the bottom of two Seat Frame(D) and Left Armrest(B) by placing Plastic Washer(3) on the threaded stem.Then insert the threaded stem into the threaded mounting position at the bottom of Seat Frame(D) and Left Armrest(B),turning clockwise until tight.

Sectional 2 ,Install the Leg(N) at the bottom of two Seat Frame(D) and Left Armrest(B) and Right Armrest(C) by placing Plastic Washer(3) on the threaded stem.Then insert the threaded stem into the threaded mounting position at the bottom of Seat Frame(D) and Left Armrest(B),turning clockwise until tight.

Note: The use of Plastic Washer(3) are OPTIONAL and are especially useful to help alleviate slight wobbleness. Some Legs may need more than one Plastic Washer(3) whilst some Legs may not need any.

Step 9

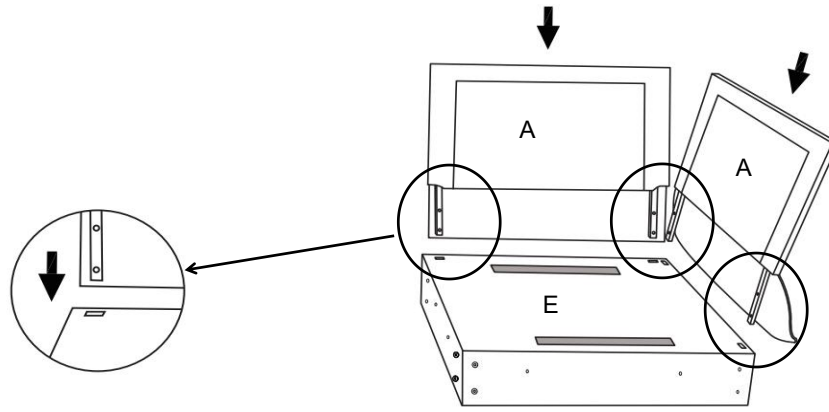

Insert the Backrest (A) into the Corner Seat Frame(E).

Step 10

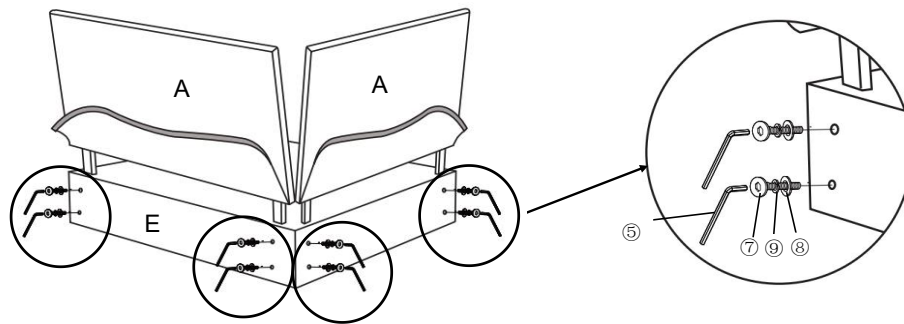

Use Bolt(7) Sping Washer (9)Flat Washer(8) with Allen Wrench(5),and turn clockwise until tight as shown.

Step 11

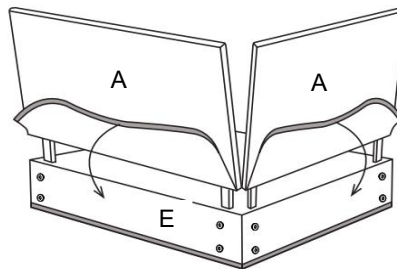

Attach the magic tape to the back of the Corner Seat Frame(E).

Step 12

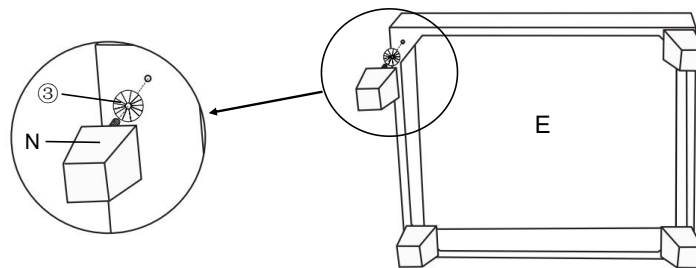

Install the Leg(N) at the bottom of Corner Seat Frame(E) by placing Plastic Washer(3) on the threaded stem. Then insert the threaded stem into the threaded mounting position at the bottom of Corner Seat Frame(E),turning clockwise until tight.

Note: The use of Plastic Washer(3) are OPTIONAL and are especially useful to help alleviate slight wobbleness. Some Legs may need more than one Plastic Washer(3) whilst some Legs may not need any.

Step 13

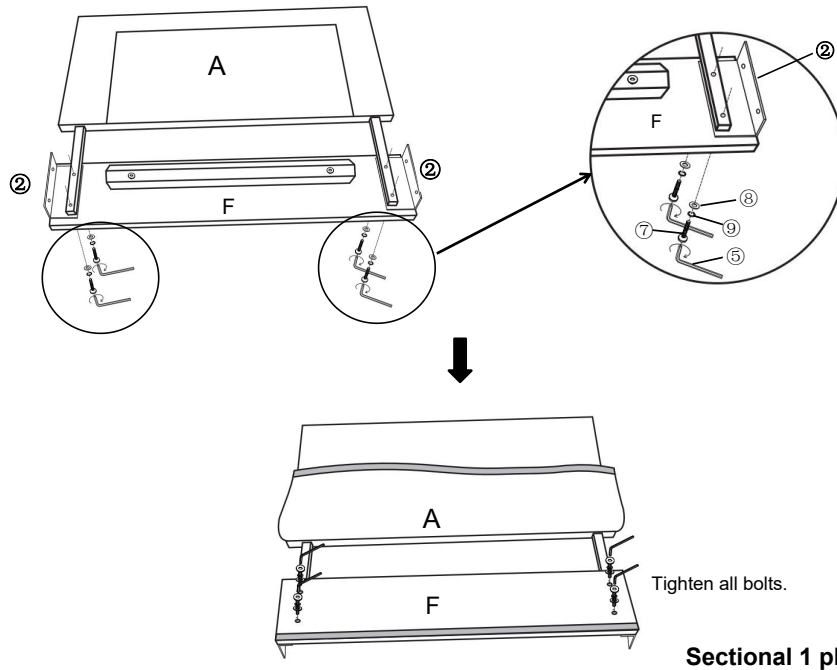

Sectional 1 pls X 2

Install the Backrest(A) and Back Rail (F) by using "L " Iron Connect plate(2), then using Bolt(7) Sping Washer (9)Flat Washer(8) with Allen Wrench(5) , then turn over and tighten all bolts clockwise. Repeat this step with the other one.

Step 14

Sectional 1

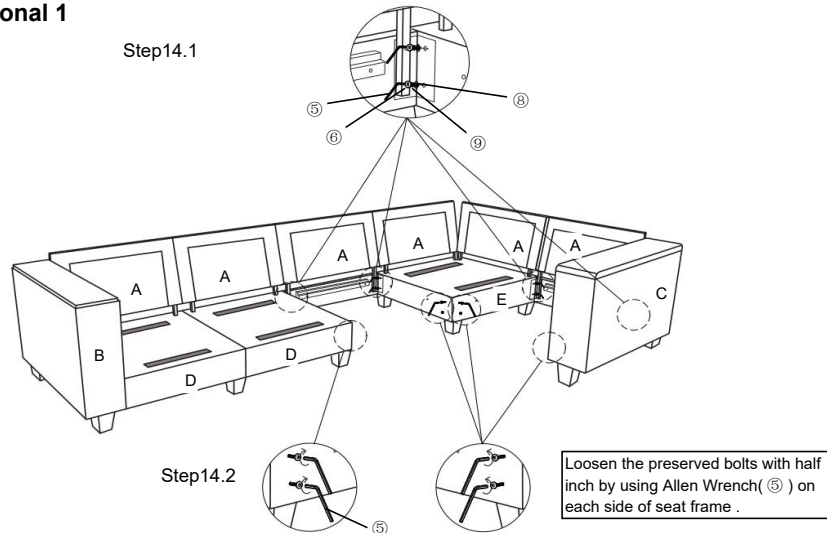

Sectional 2

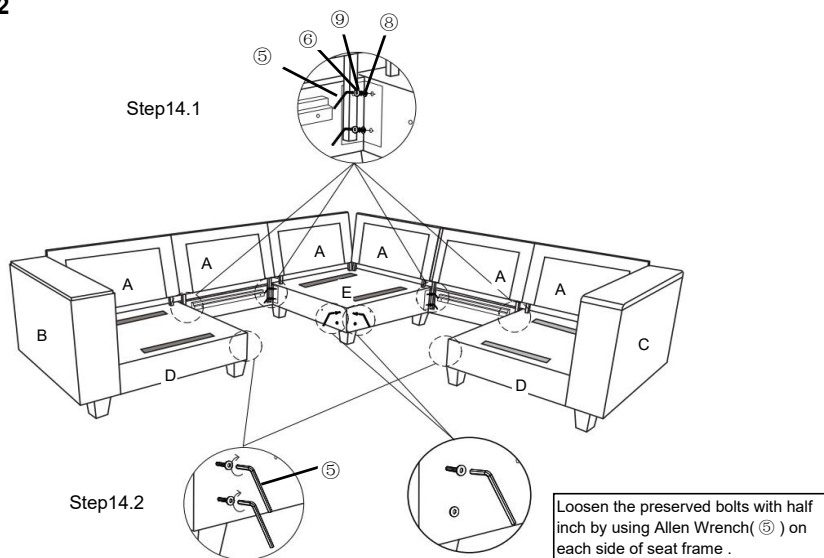

Sectional 1 ,Sectional 2 ,Step14.1 Connect the Seat Frame(D)to the Corner Seat Frame(E)with Semi-assembly Parts(Step 13) by using Bolt(6), Sping Washer (9) Flat Washer(8) with Allen Wrench(5) ,turning clockwise until tight. Repeat this step with the Corner Seat Frame(E) and Right Armrest(C).
Step14.2 Loosen the preserved bolts with half inch by using Allen Wrench(5) on each side of seat frame .

Step 15

Sectional 1

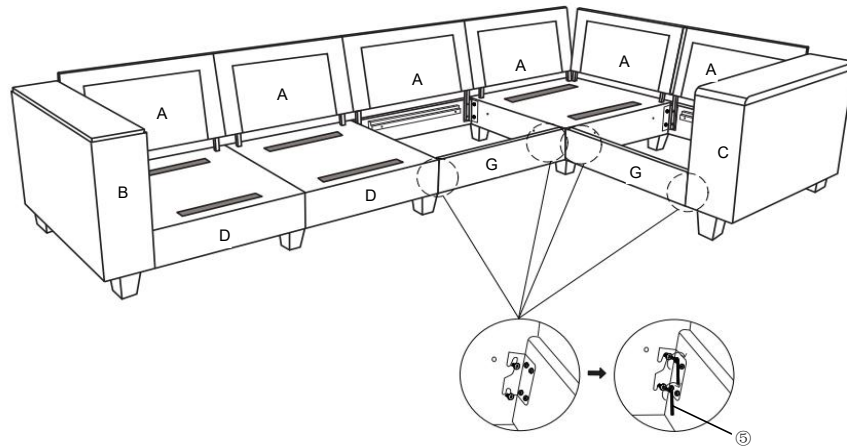

Sectional 2

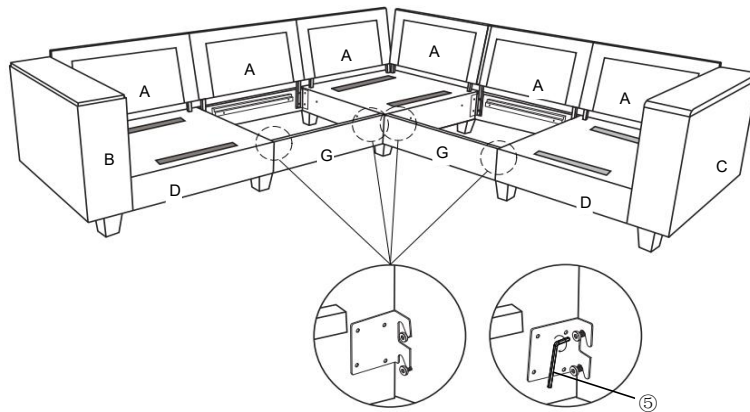

Slide the hook of Front Rail(G) into the bolts on the side of seat frame as picture shown, then tighten the bolts.

Step 16

Sectional 1

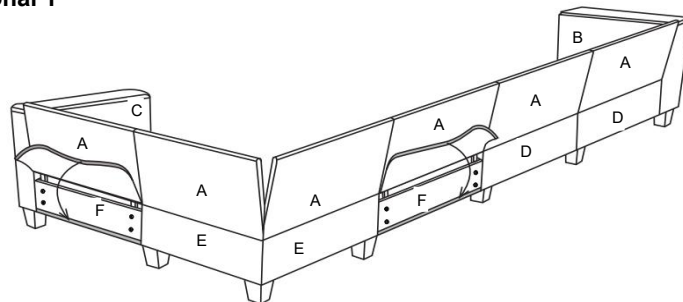

Sectional 2

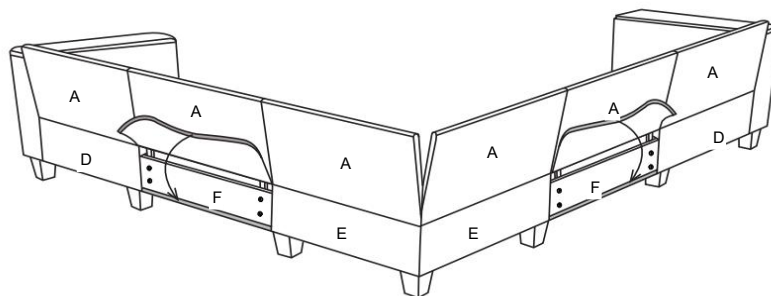

Attach the magic tape to the back of the Back Rail (F).

Step 17

Sectional 1

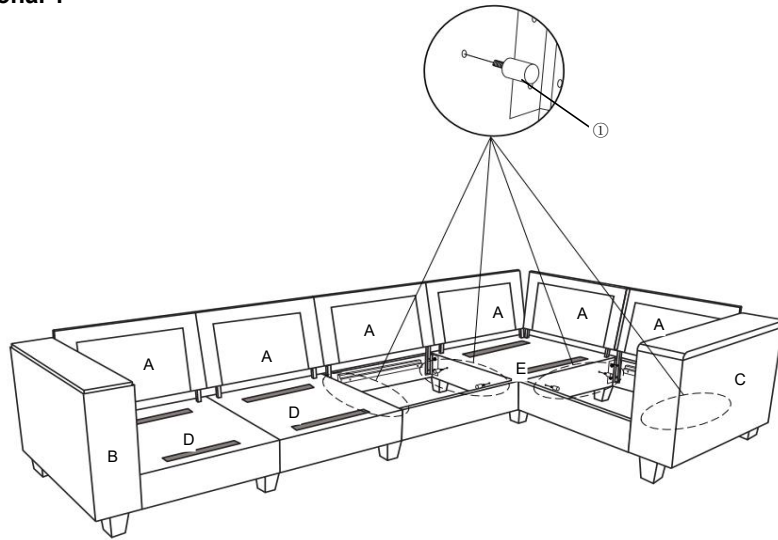

Sectional 2

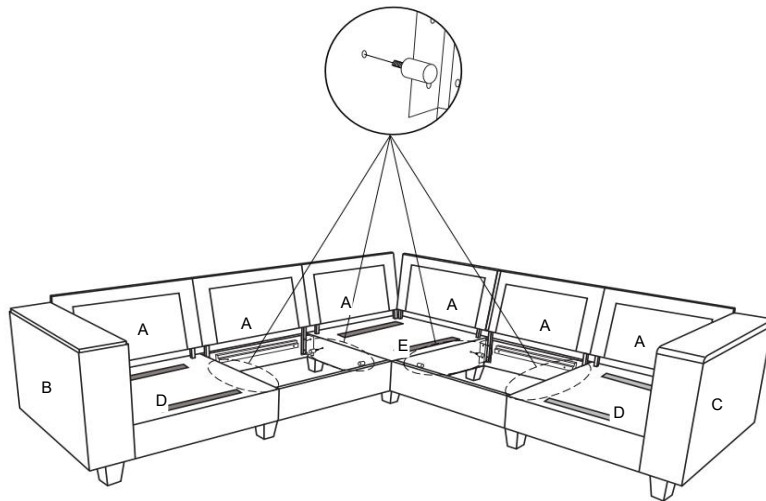

Install eight Wood dowels (1) into the preformed hole of Seat Frame(D),Right Armrest(C) and Corner Seat Frame (E).

Step 18

Sectional 1

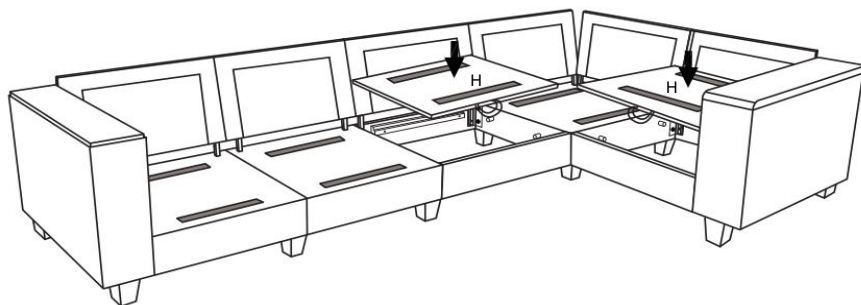

Sectional 2

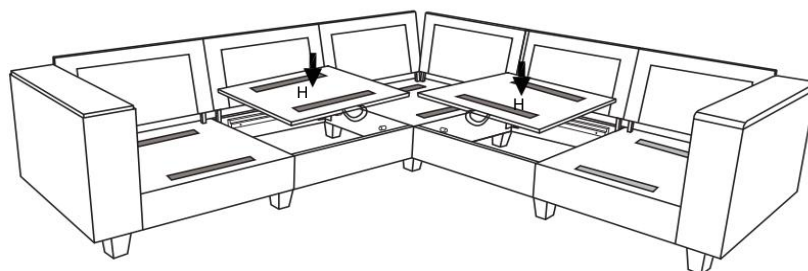

Put the Seat Panels (H) on the middle positions.

Step 19

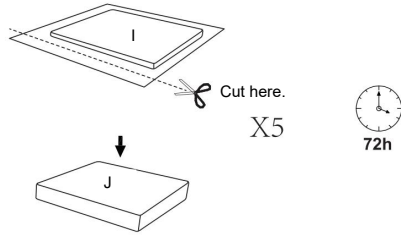

Cut the Seat Cushion Packages (I) , then take out Seat Cushions (J). Full decompression may take up to 72 hours.

Step 20

Sectional 1

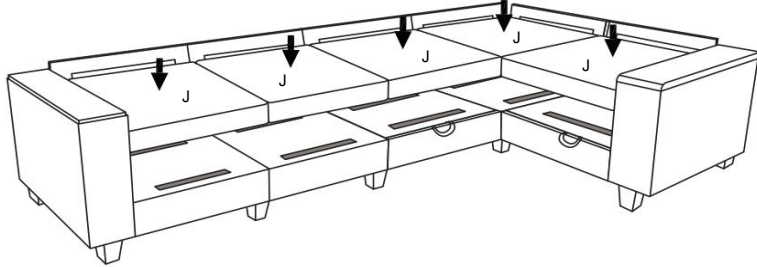

Sectional 2

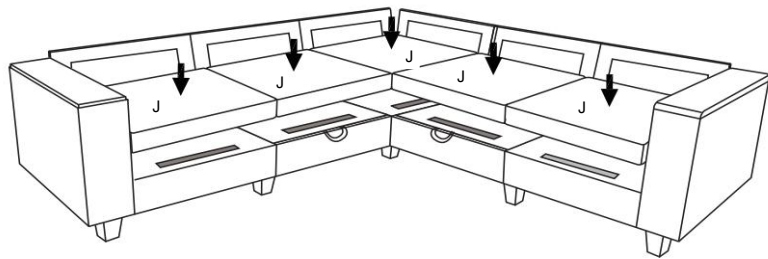

Put the Seat Cushions (J) on your sofa.

Step 21

Sectional 1

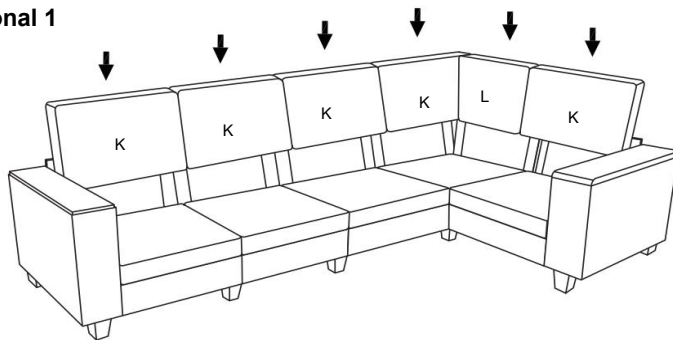

Sectional 2

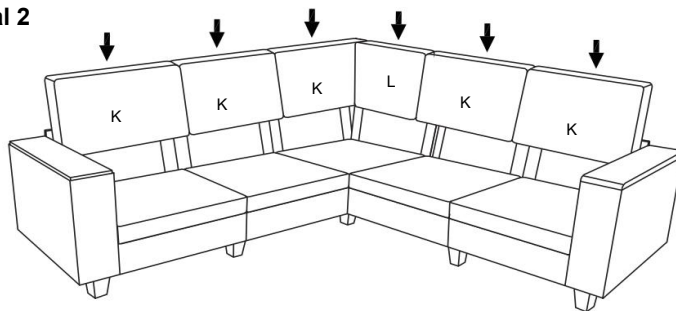

Put the five Back Cushions (K) and one Corner Back Cushion (L) on your sofa.

Step 22

Sectional 1

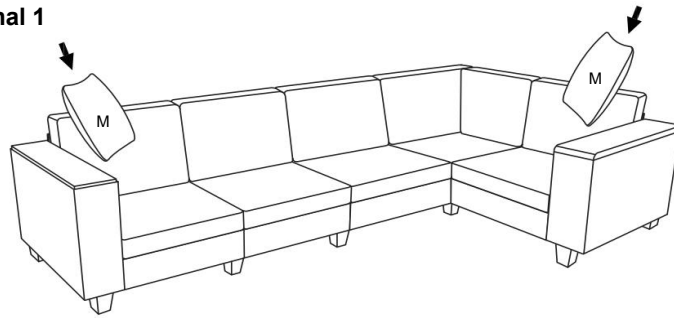

Sectional 2

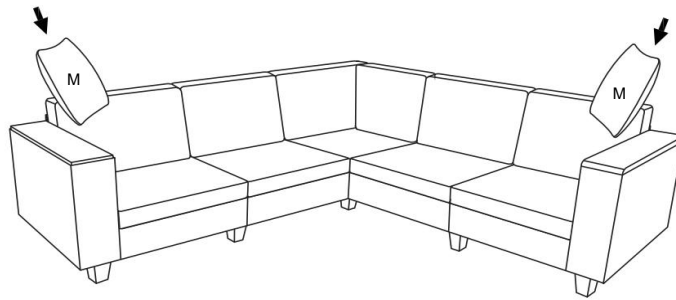

Put the Pillows (M) on your sofa.

COMPLETE

Sectional 1

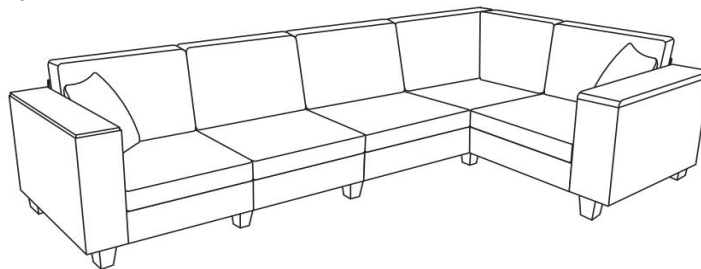



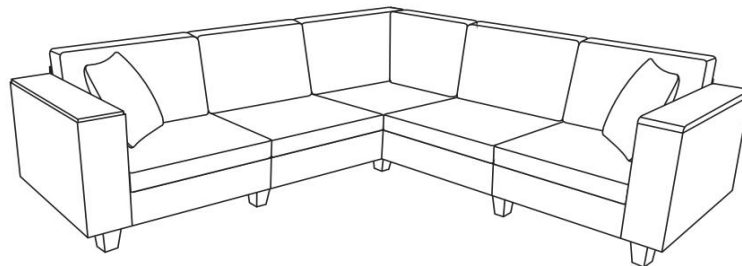







Sectional 2



Your sofa is ready for use !

Care & Maintenance

- ✓  • Furniture may scratch floors. We recommend using furniture pads to protect your floors.
 - ⊘  • Do not put hot items directly on furniture surface.
 - ⊘  • Do not clean furniture with harsh cleansers or polish.
 - ⊘  • Do not place furniture under direct sunlight.
 - ⊘  • Do not place furniture near heating or cooling vents.
 - ⊘  • Do not write on furniture without a padded barrier to protect the surface.
 - ⊘  • Do not place furniture outside . For indoor use only.
 - ⊘  • Not for commercial use. For residential use only.
 - ⊘  • Stains may be removed with mild soap solution and damp cloth.
 - ⊘  • Children should not climb or jump on the furniture.
-
- ✓  • Dust and pick-up spills using a clean, non-colored, lint-free cloth.