





ASSEMBLY INSTRUCTIONS

- IMPORTANT NOTE :**
- * PLACE ALL WOODEN PARTS ON A CLEAN AND SMOOTH SURFACE SUCH AS A RUG OR CARPET TO AVOID THE PARTS FROM BEING SCRATCHED.
 - * BEFORE YOU BEGIN, KINDLY FOLLOW THE ASSEMBLY INSTRUCTIONS STEP BY STEP.
 - * DO NOT TIGHTEN ALL SCREWS UNTIL THE CHAIR IS FULLY SET-UP.

HARDWARE LIST		PART LIST	
A	JCBC M6 x 25mm + S/W M6 + F/W M6 x 13mm 	4PCS	1 LEG L/R 2PCS
B	JCBC M6 x 55mm + S/W M6 + F/W M6 x 13mm 	4PCS	2 TOP REST 1PC
C	JCBC W SCREW M7 x 40mm 	1PC	3 CHUSION SEAT 1PC
D	FH SCREW #8 x 25mm 	16PCS	4 CORNER BLOCK (LONG) 2PCS
E	ALLEN KEY M4 	1PC	5 CORNER BLOCK (SHORT) 2PCS

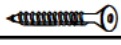
CAUTIONS :

(1) DO NOT FULLY-TIGHTEN THE NUT OR NUT BOLTS INITIALLY UNTIL ALL NUTS OR BOLT IS READY ASSEMBLED.

(TO AVOID CAUSING DAMAGES TO THE THREAD, DO NOT OVER-TIGHTEN THE NUTS OR BOLTS.)

(2) KEEP ALL HARDWARE PART OUT OF REACH OF CHILDREN.

