

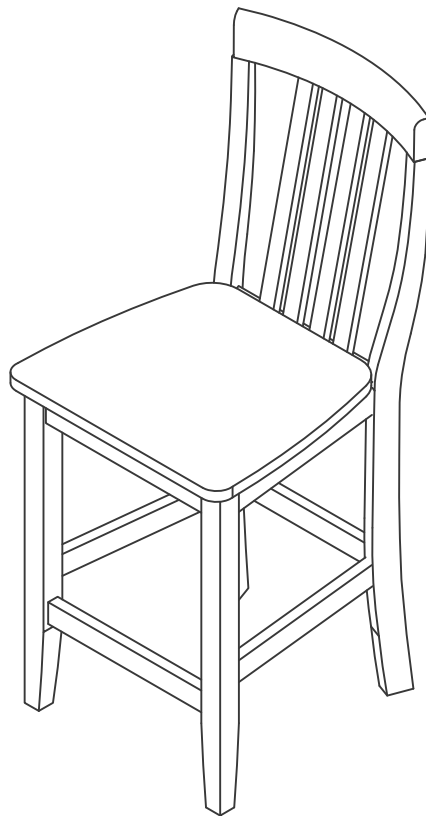

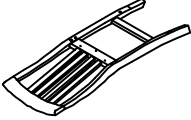

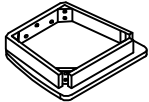

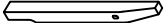

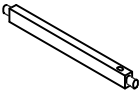

Bar Stool



PART LIST

				
Back Frame 2 PCS	Seat Frame 2 PCS	Front Leg (L & R) 4 PCS	Side Stretcher (L & R) 4 PCS	Front Stretcher 2 PCS

HARDWARE LIST

				
M6 X 80mm Long Bolt 8 PCS (Extra 2)	M6 X 50mm Bolt 8 PCS (Extra 2)	M6 X 40mm Short Bolt 6 PCS (Extra 2)	Spring Washer 22 PCS (Extra 2)	Flat Washer 22 PCS (Extra 2)
				
Allen Wrench 1 PC	4 x 38mm Screw 12 PCS			

ADDITIONAL TOOLS (Not Provided)

Note: It is not recommended to use power tools during assembly.



Phillips Head Screwdriver

Step 1. Attach seat frame (part B2) to back frame (part A2) using long bolts (part #1), short bolts (part #3), spring washers (part #4), flat washers (part #5) and allen wrench (part #6).
 NOTE: Do not tighten bolts at this time.
 NOTE: Please ensure you are using short bolts (part #3) in center to prevent damage to back frame (part A2).

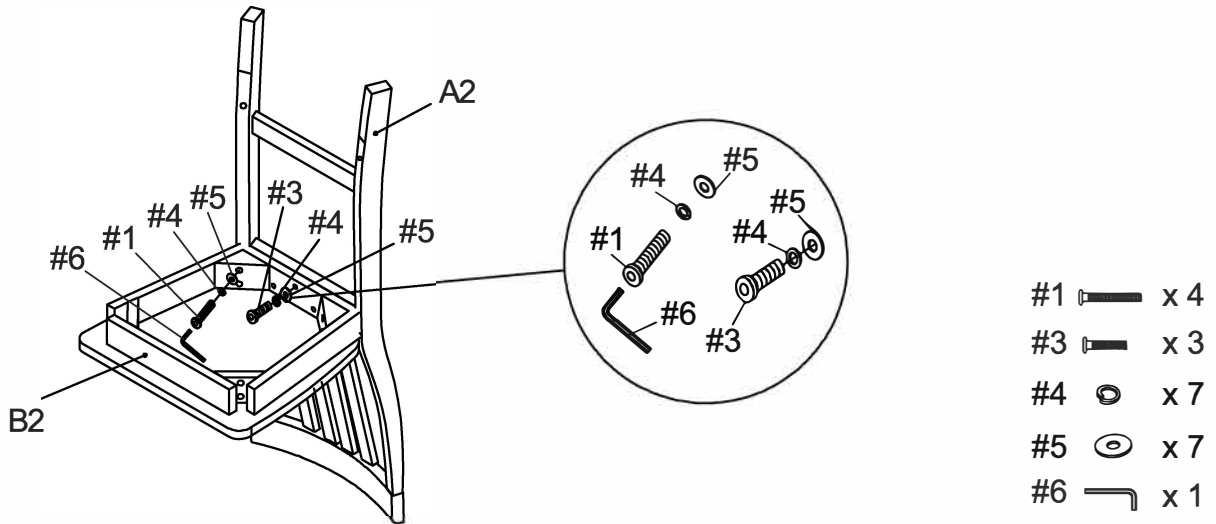

Step 2. Attach front legs (part C2) to seat frame (part B2) using bolts (part #2), spring washers (part #4), flat washers (part #5) and allen wrench (part #6).
 NOTE: Do not tighten bolts at this time.
 NOTE: The front legs (part C2) are marked "R" for right and "L" for left.

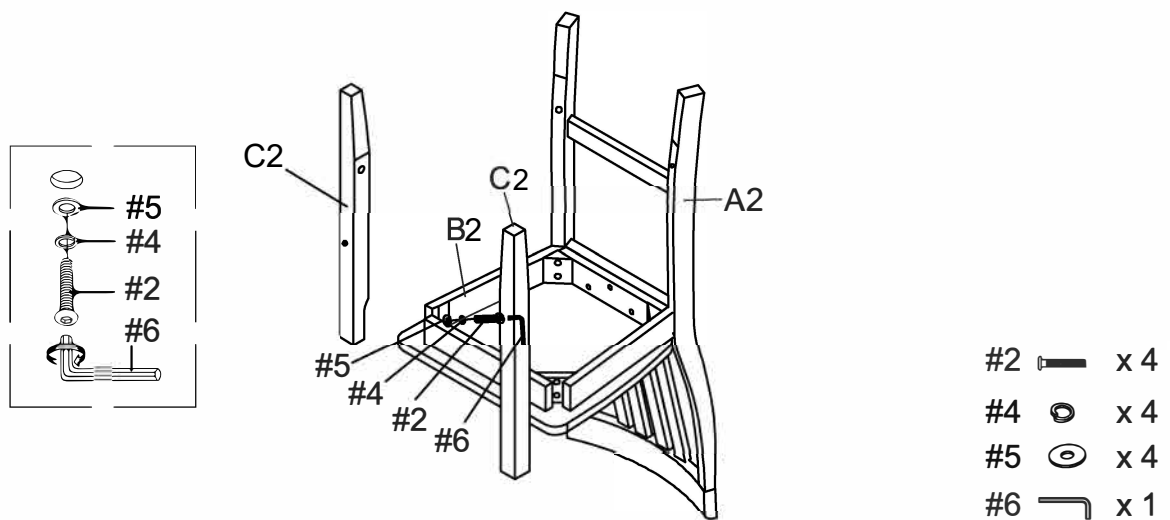

Step 3. Insert side stretchers (part D2) into assembled unit (parts A2 & C2). Insert front stretcher (part E2) into front legs (part C2).

NOTE: The side stretchers (part D2) are marked "R" for right and "L" for left.

NOTE: If side stretchers (part D2) are not flushed with back frame (part A2) and front legs (part C2), switch the front legs (part C2).

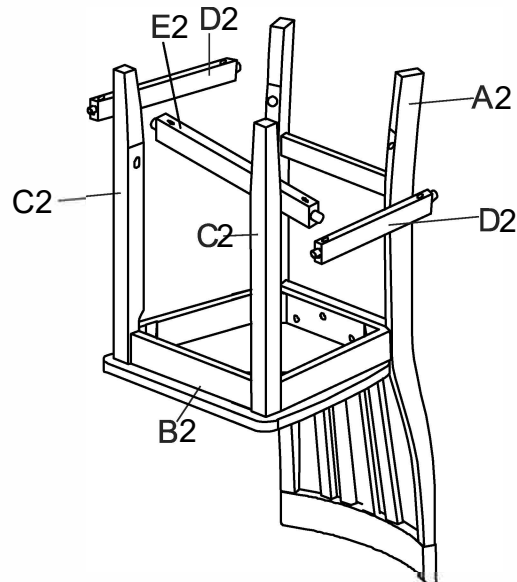

Step 4. Finger-tighten bolts (part #2), do not overtighten. Secure stretchers (parts D2 & E2) using screws (part #7) and phillips head screwdriver.

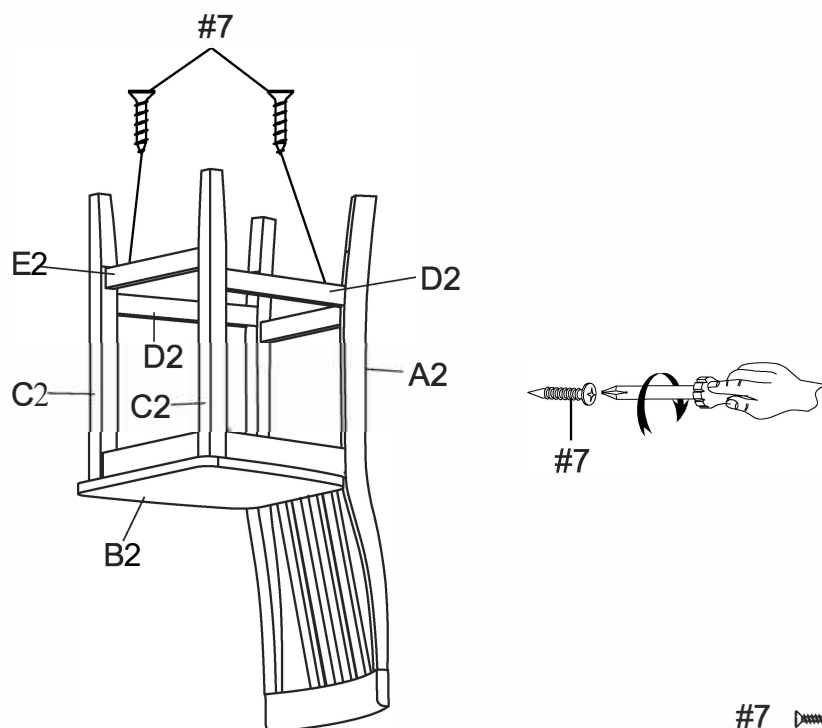

#7  x 6

Step 5. Carefully turn unit upright. Ensure unit is leveled and square then tighten all bolts using allen wrench (part #6). Repeat steps 1-5 for remaining stool.

