





# ASSEMBLY INSTRUCTIONS

## QUEEN / FULL (4+4)





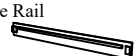

### (Box 1) BOX OF HEADBOARD & FOOTBOARD

No	ITEM	Qty
A	Headboard 	1 pc
B	Footboard 	1 pc
C	Headboard Leg 	2 pcs
D	Bed Slats 	4 pcs
E	Bed Slats Support 	4 pcs

### (Box 2) BOX OF SIDE RAIL

No	ITEM	Qty
F	Side Rail 	2 pcs

### (Box 1) HARDWARE LIST

No	ITEM	Qty
1	JCBC M6 x 40mm 	4 pcs
2	SPRING WASHER 1/4" Blk 	4 pcs
3	Flat Washer 1/4"ID x 13mmOD Blk 	4 pcs
4	ALLEN KEY m4x65mm Blk 	1 pc
5	ALLEN KEY m5x65mm Blk 	1 pc
6	Flat Head Chipboard Screw m4x32mm Rbw 	16 pcs

**STEP 1.1** Attach Head Board Leg ( C ) to Head Board ( A ) as shown using JCBC BOLT( 1 )with Spring Washer ( 2 ), Flat washer ( 3 )and securing with ALLEN KEY ( 4 ).  
**STEP 1.2 :** Fix the other holes with Csk Screw ( 6 ) as shown.

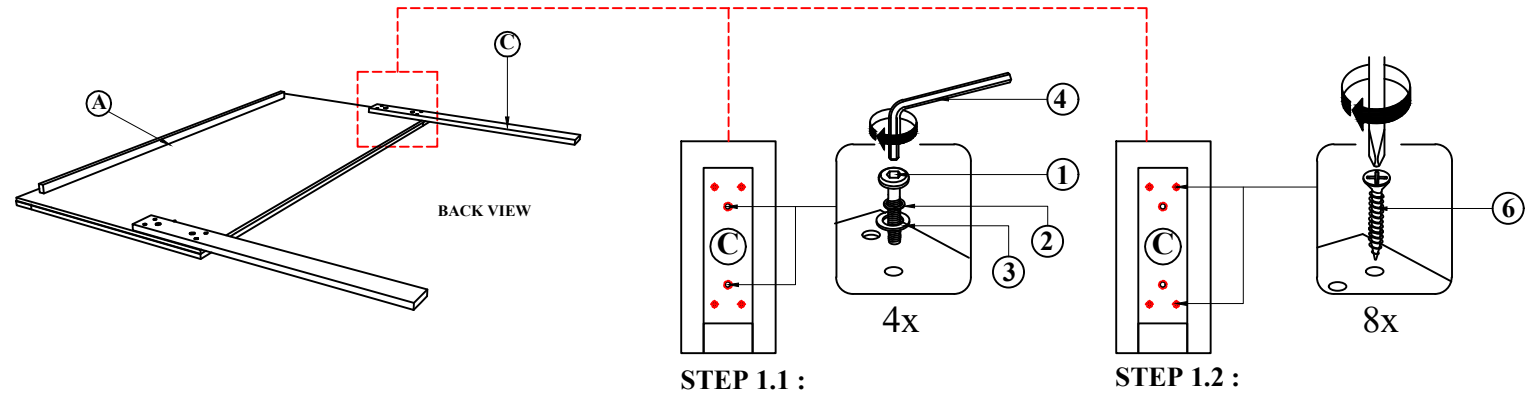

**STEP 2 :** Hook SIDE RAIL(F) TO HEAD BOARD (A) closely and push down to fit. repeat step 2 with other end of rail to hook onto FOOTBOARD (B).

### STEP 2.2 :

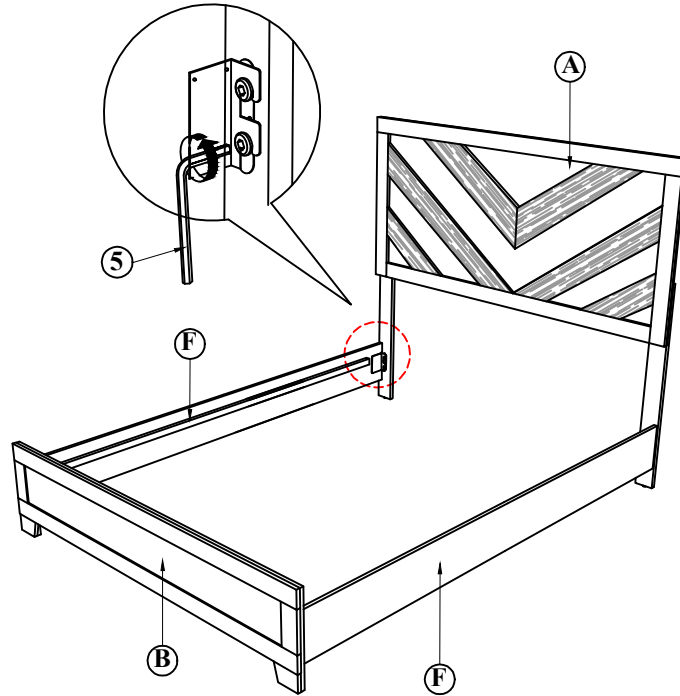

**STEP 3 :** Tighten the 4 Corner with Allen Key ( 5 ). Fix the Bed Slat Support Leg ( E ), to Bed Slat ( D ) as shown . Install the bed slat ( D ) to side rail ( F ) and tighten with Csk Screw ( 6 ) as per diagram shown. (NOTE: THE SETUP MUST DONE AT THE DECIDED LOCATION FOR THE BED TO OBTAIN PERFECT STABILITY)

### STEP 3.2 :

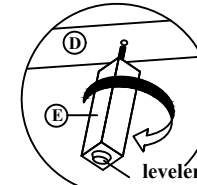

### STEP 3.1 :

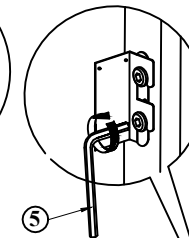

### STEP 3.3 :

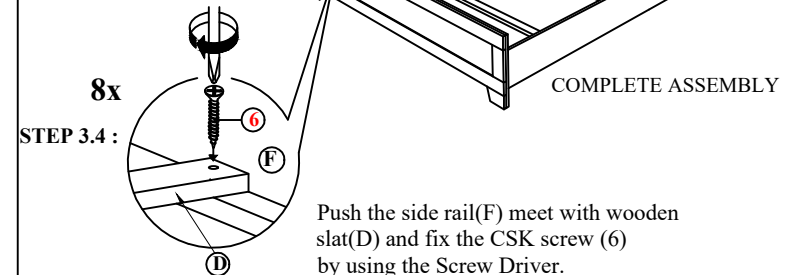
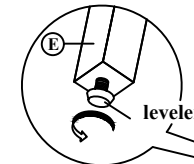

Push the side rail(F) meet with wooden slat(D) and fix the CSK screw ( 6 ) by using the Screw Driver.