

HAPPINESS HAPPINESS INSTALLATION

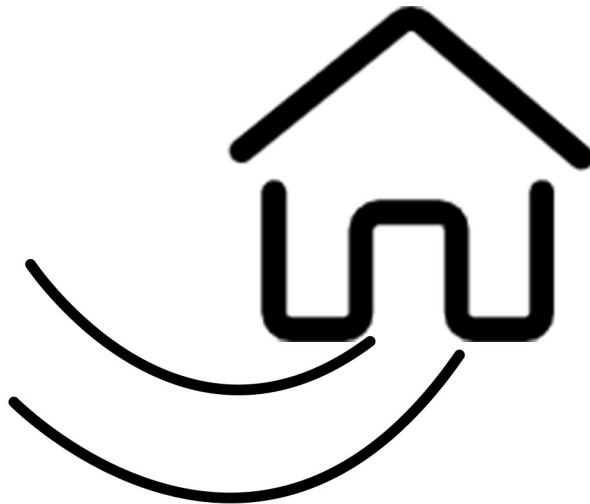

- If you have any questions with the product, please contact us by:
- **Email: customerservice@zoy-living.com**
(we will reply to you within 24 hours)

Assembly Instructions

CD0276-WF

Your recliner comes packaged in three boxes. Carefully remove all of components from the packaging and set aside for assembly.

Recliner: reclines the chair to 150 degrees, back and footrest work together fully powered by the remote to release the built-in footrest.

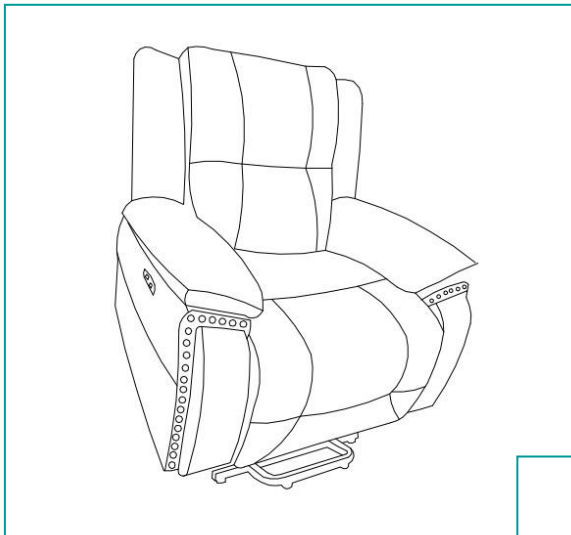
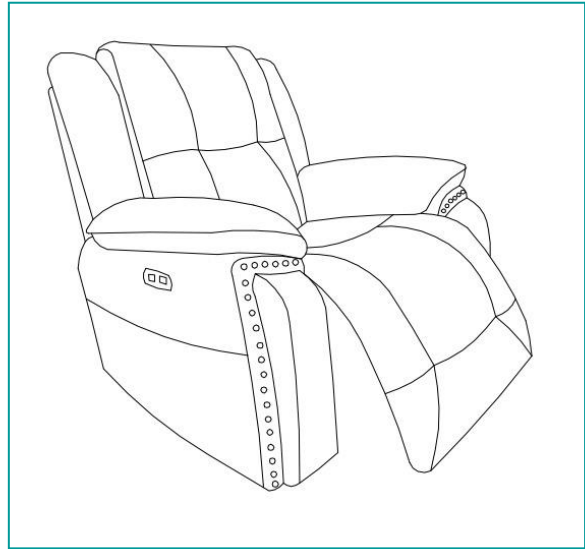





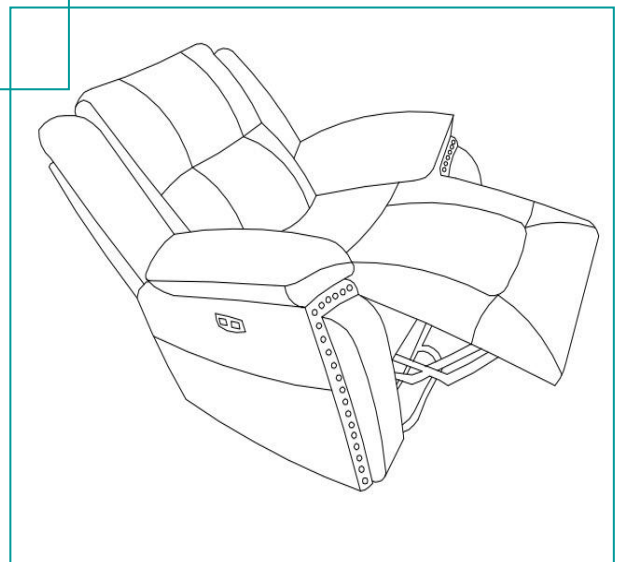

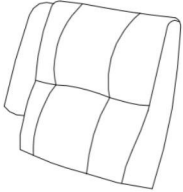
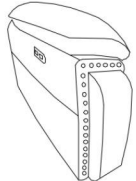

LIFT MECHANISM: push the entire chair up from its base to help the senior to stand.

Deluxe Design: this lift chair is the perfect companion for any media room or living room.

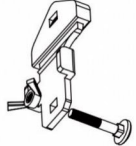

FITTING LIST

				
A 1* Chair Seat	B 1* Right Studded Border	C 1* Chair Back	D 1* Left Armrest	E 1* Right Armrest
BOX 1		BOX 2	BOX 3	
				
F 1* Power Source	G 1* Remote Control	H 1* Power Cable	I 1* Transformer	J 2* Supporting Feet

ASSEMBLY INSTRUCTIONS

STEP 1: Place the **Chair Seat (A)** on its back on a flat smooth surface. Take out **Supporting Feet (J)** from a small plastic bag. Assemble the two supporting feet as shown on the bottom of mechanism to avoid toppling and falling.

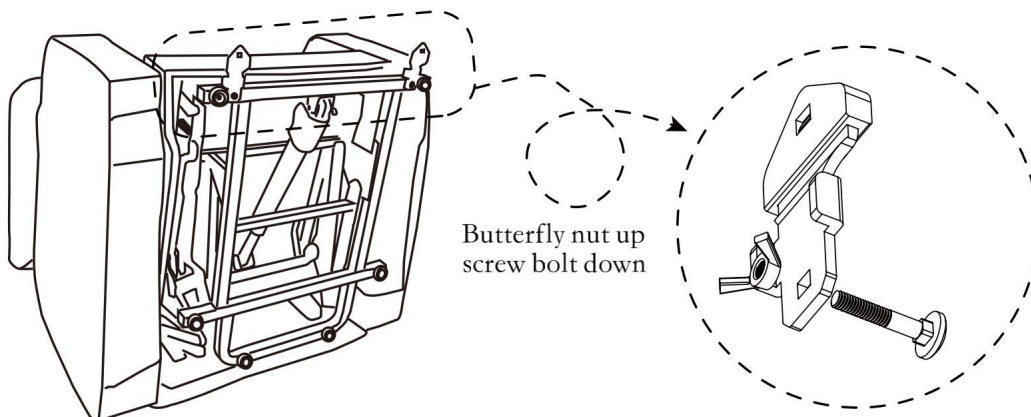

- **STEP 2:** Insert two **armrests** to the **Chair Seat (A)**, make sure the slots on the armrests fully assembled to the bottom part.

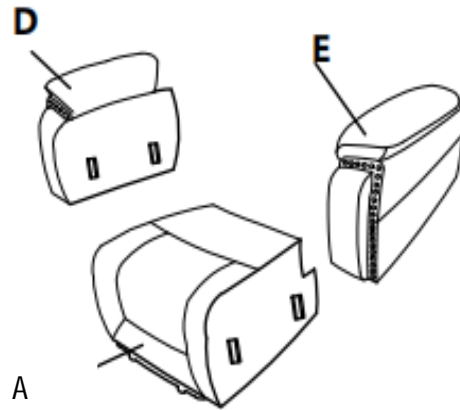

- **STEP 3:** Insert **Chair Back (C)** to the **Chair Seat (A)** , make sure the slots on the back fully assembled to the bottom part. Then Attach **Right Studded Border (B)** to Seat Back by aligning the metal grooves on Back and Studded Border.

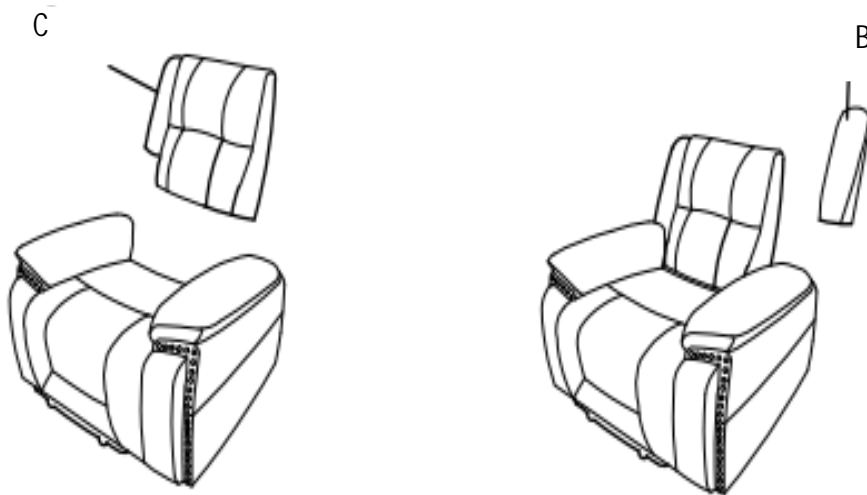

No.1, No.2 and No.3 wire connect with the backrest and chair seat.

No.4 wire connects with backrest and power source(F).

No.5 wire connects with backrest and massage remote(G).

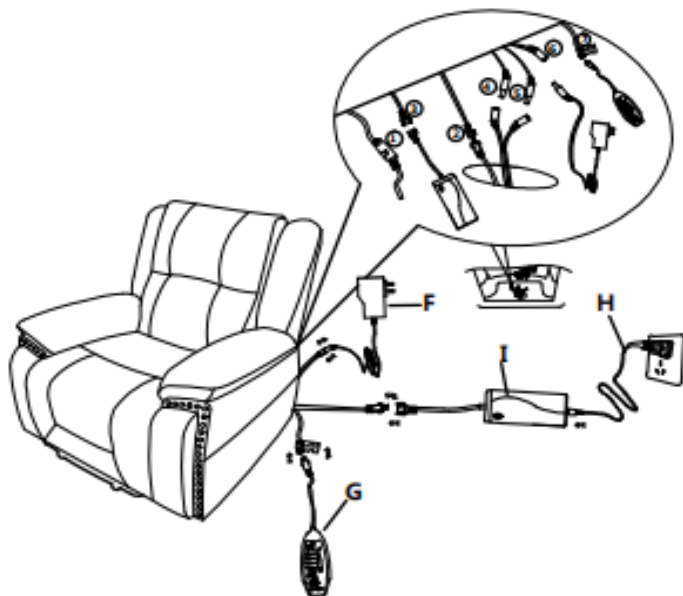

NOTE

1. Two same color wires connect.
2. Plug both the Power Cable(H) and Power Source (F) into outlet to get the recliner working.

USAGE INFORMATIONS

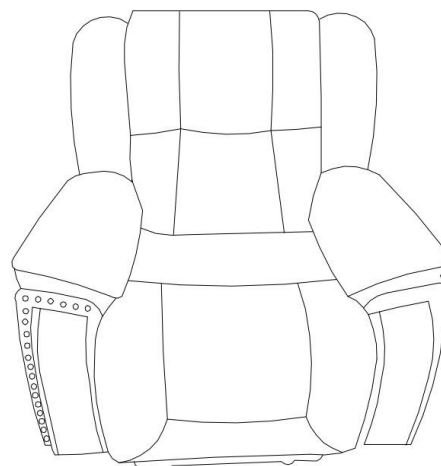
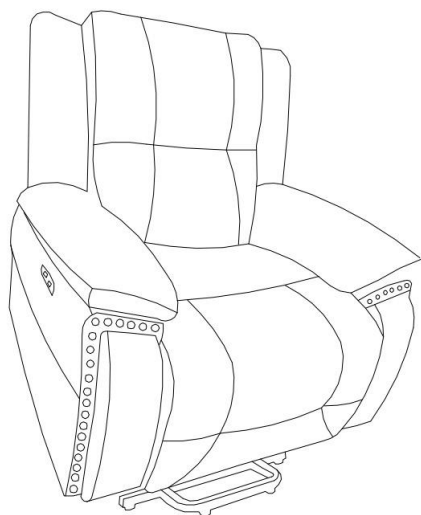

Warnings

1. Please check if the components of the chair are all included and can be used normally.
2. Assemble all components according to the instruction correctly before you connect the chair to the power.
3. Please DO NOT sit on the armrests or footrest to eliminate the risk of tipping over.
4. If the chair is damaged or doesn't match the website description, please send clear pictures of the product and label of the carton to our service team for further help.
5. If the recliner doesn't work, you may try the following measures for self-checking firstly:
 - a) Check if all the cables are connected;
 - b) Check if the light of transformer is on.

If the chair still doesn't work, please feed the information back to our customer service in time and we'll help you solve the matter as soon as possible.

6. If you have any questions with the product, please contact us by:

Email: customerservice@zoy-living.com (we will reply to you within 24 hours)

