

DRESSER



- Please keep instructions for future reference.
- Check the quantity and irregularity of parts and hardware before you start.



PARTS

#1 1pc

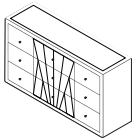

Dresser

#2 4pcs



Leg

#3 1pc

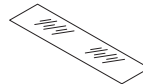

Glass Top

#4 1pc



Leg Support with Plastic Washer & Adjuster

HARDWARE

#A 1pc



Allen Key With Ball

#B 4pcs



JCBC Bolt M6 x 30mm

#C 8pcs



CSK Screw M4 x 20mm

#D 4pcs



Spring Washer M6

#E 8pcs



Flat Washer Small M6 x 13mm x 1.0

#F 4pcs



Flat Washer Medium M7 x 19 x 2.0

#G 1pc

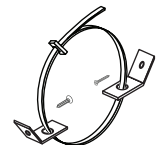

Anti-Tipping Hardware Kit

ASSEMBLY INSTRUCTIONS

1

Part #1 x1pc

Part #3 x1pc

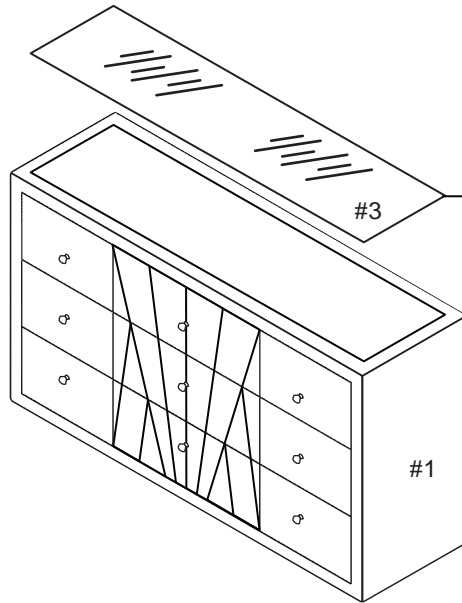

Lift the Glass-Top #3 gently and carefully place it at safe before assembly begin.

2

Align legs (#2) to the dresser (#1), then secure by using the following screws and bolts with washers as shown in the diagram.

Part #1 x1pc

Part #2 x4pcs

Part #4 x1pc

Hardware #A x1pc

Hardware #B x4pcs

Hardware #C x8pcs

Hardware #D x4pcs

Hardware #E x8pcs

Hardware #F x4pcs

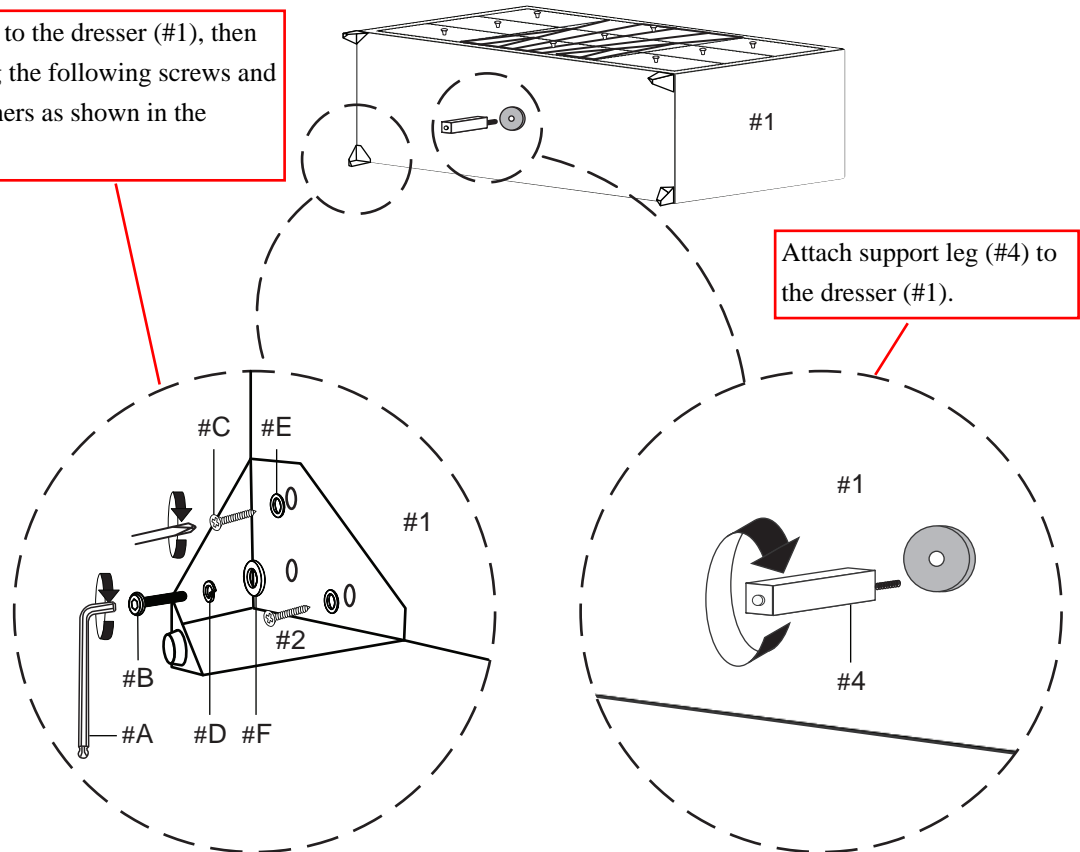

Attach support leg (#4) to the dresser (#1).

3

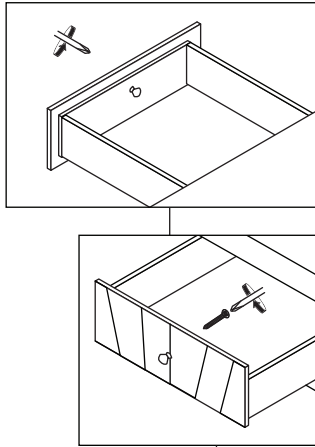

Secure knobs to the exterior of the drawers.

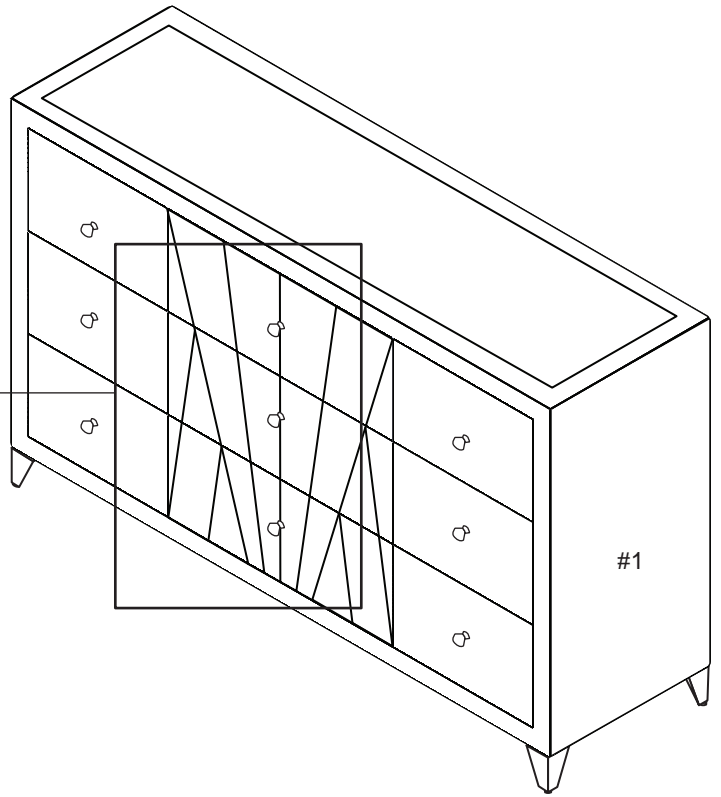

4

Place the Glass-Top #3 back to the top surface of Dresser #1.

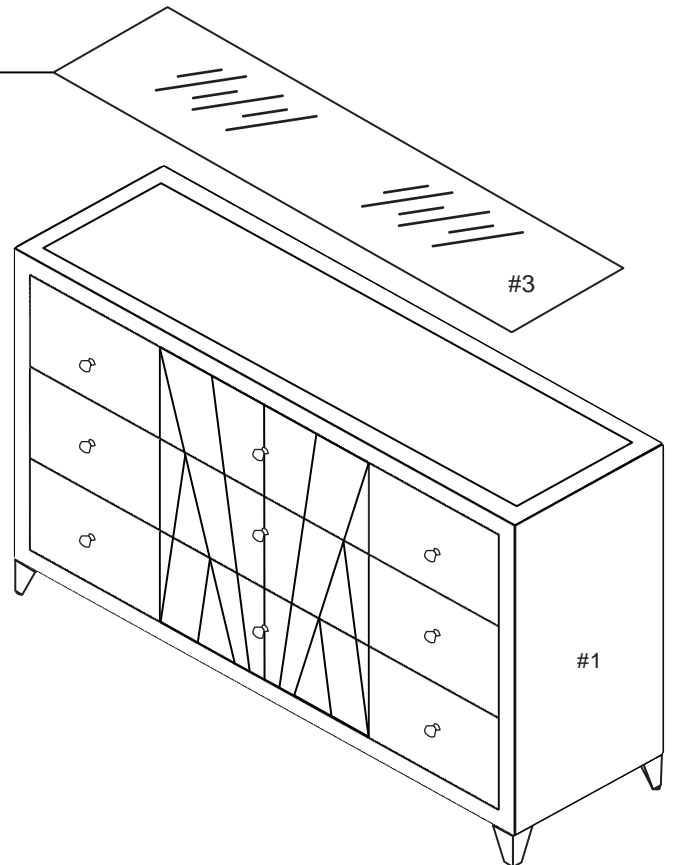

5

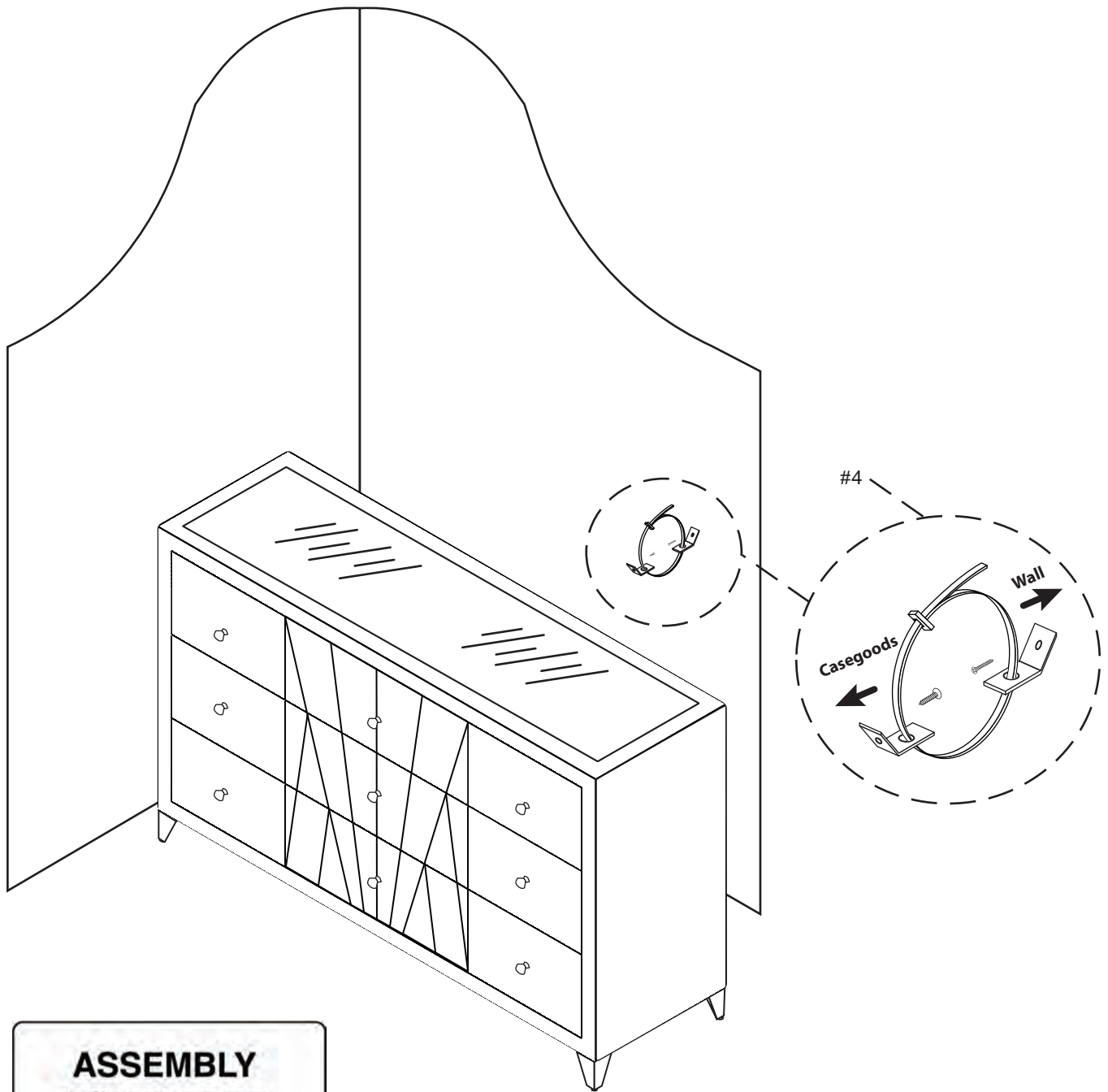

ASSEMBLY COMPLETED



Please ensure the furniture rests on an even and flat surface. If the product wobbles or feels loose, double-check all bolts and/or screws are properly tightened and secured.



Keep this handy!

Please retain this instruction manual and any order-related information for future reference.



Lift, don't drag!

To avoid damage to product please always LIFT the product when transporting or adjusting the placement.

ASSEMBLY INSTRUCTIONS

Wall Mounting and Fixing



EXPANSION WALL ANCHOR

Our provided expansion wall anchors are only suitable for masonry walls, such as drywall, plaster or concrete, and are best for holding lightweight items or for anti-tip prevention. If you are unsure of the correct wall anchor to use with the product, please request professional guidance. Liability for product damage or failure due to using the incorrect anchors will fall on the installer.

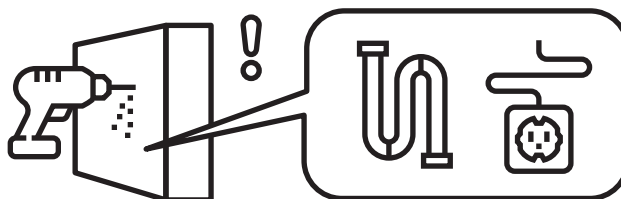

CHECK BEFORE PROCEEDING

Prior to drilling or hammering, please check for wires or pipes. We recommend using a stud finder to locate a stud, which will offer more appropriate resistance and hold more weight.

QUICK TIPS

1. If unsure of the proper size, always choose a larger screw and wall anchor.

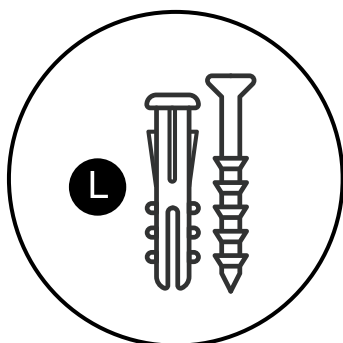

2. Match the drill bit to the wall anchor and hole size.

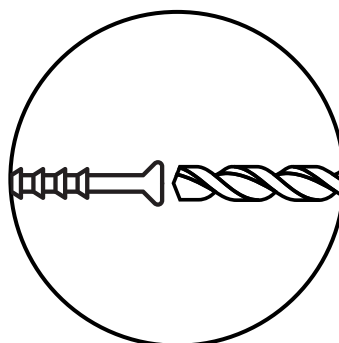

3. Only drill horizontally. Do not force the drill or enlarge the hole for the wall anchor.

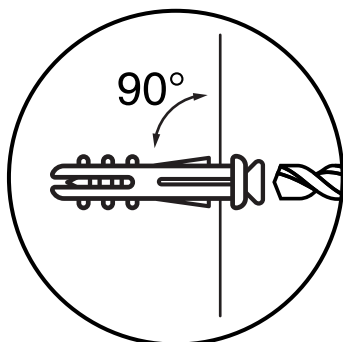

4. Take extra care when drilling into high walls or ceramic tiles. Wall anchors should be a tight fit for the hole. Never use wall anchors in ceilings.

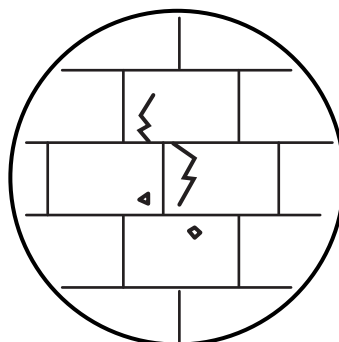

MAINTENANCE



We recommend a yearly check to see if the wall anchor or screw has loosened. If so, please remove the existing wall anchor and screw, and use a new anchor.