

No	Part	Qty
1	Side panel	2
2	Top panel	1
3	Back panel	1
4	Pedestal	1
5	Shelf	1
6	Siding	2
7	Top moulding	1
8	Glass Door	2
9	Glass shelf	3
10	Drawer front panel	1
11	Drawer side panel	2
12	Drawer back panel	1
13	Drawer bottom panel	1
14	Support for bottom panel	1

No	Part	Qty
A	Drawer Slides (14")	1
B	Screw Ø6x10	6
C	Screw Ø3.5x12	8
D	Angle iron	8
E	Screw Ø4x16	44
F	Screw Ø4x35	6
G	Screw Ø3x16	4
H	Handles 360mm	1
I	Screw M4x22	2
J	Quickfit (Ø5x33)	43
K	Cam Ø15x12	47
L	Quickfit Ø7x66	2
M	Concealed lamp	1
N	Spring hinge (Ø26)	6
O	Screw Ø4x20	6
P	Handles 180mm	2
Q	Screw M4x12	4
R	Plastic Cushion	4
S	Gasket	4
T	Shelf support for glass	12
U	No-bump plastic	4
V	Metal piece	2

- Please check contents and read instructions before commencing assembly.
- Please use a soft mat to avoid damaging during assembly
- Assemble this article following the enclosed instructions carefully.

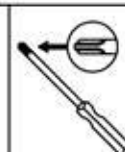

STEP1

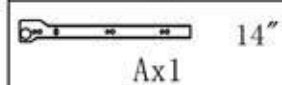
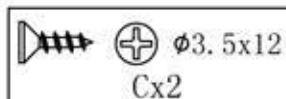
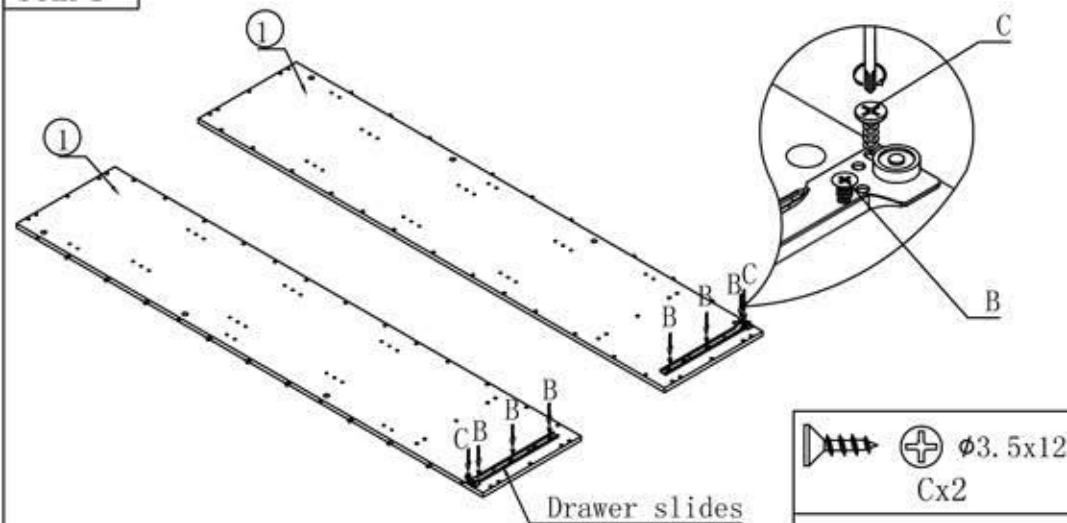

Drawer slides

STEP2

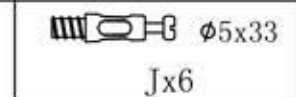
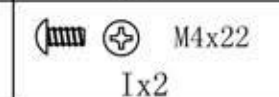
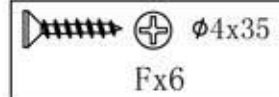
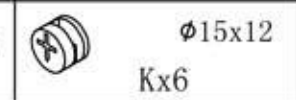
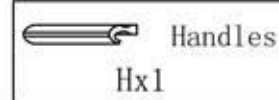
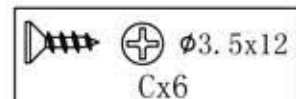
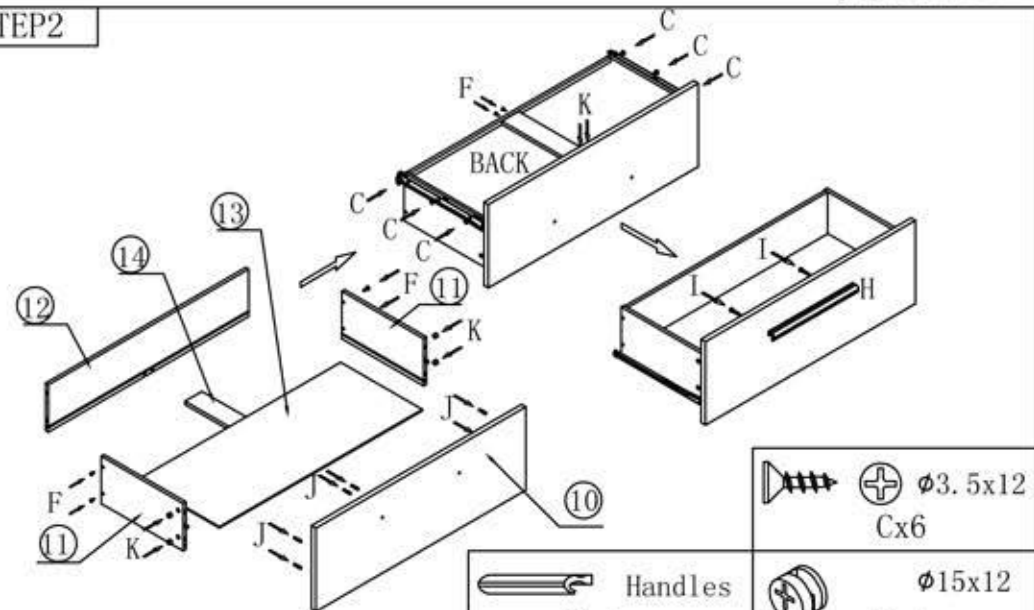

STEP3

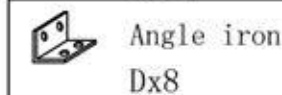
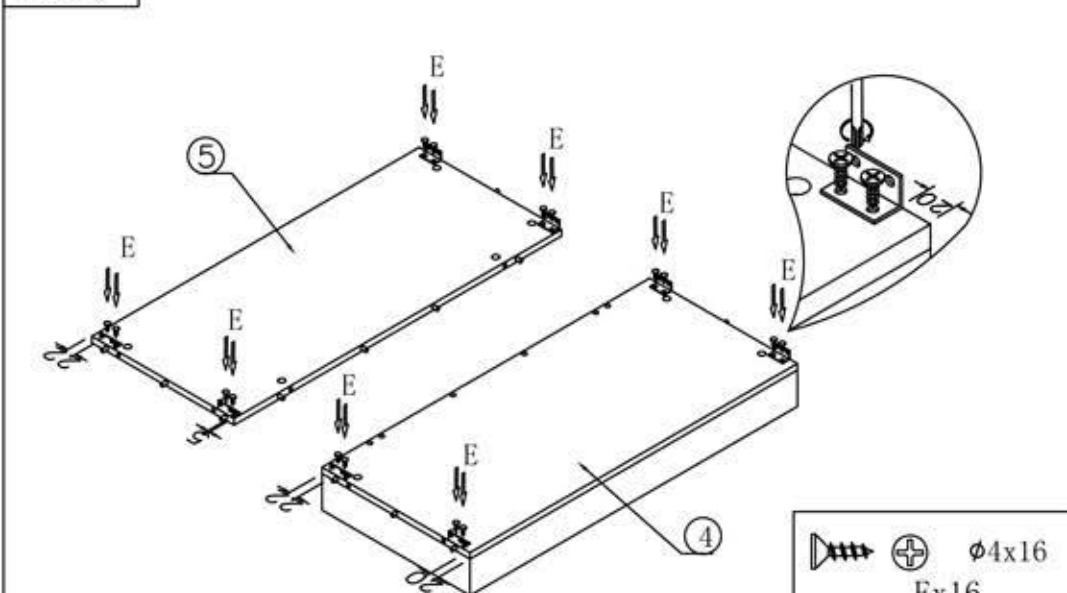

STEP4

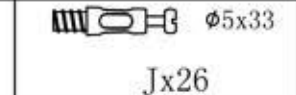
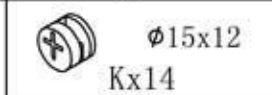
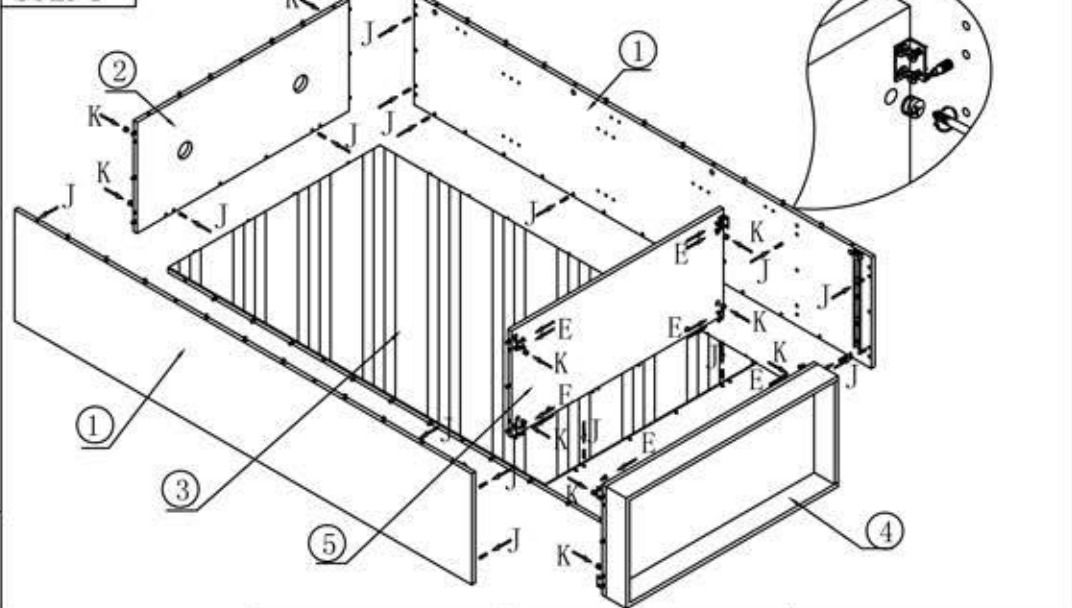

STEP5

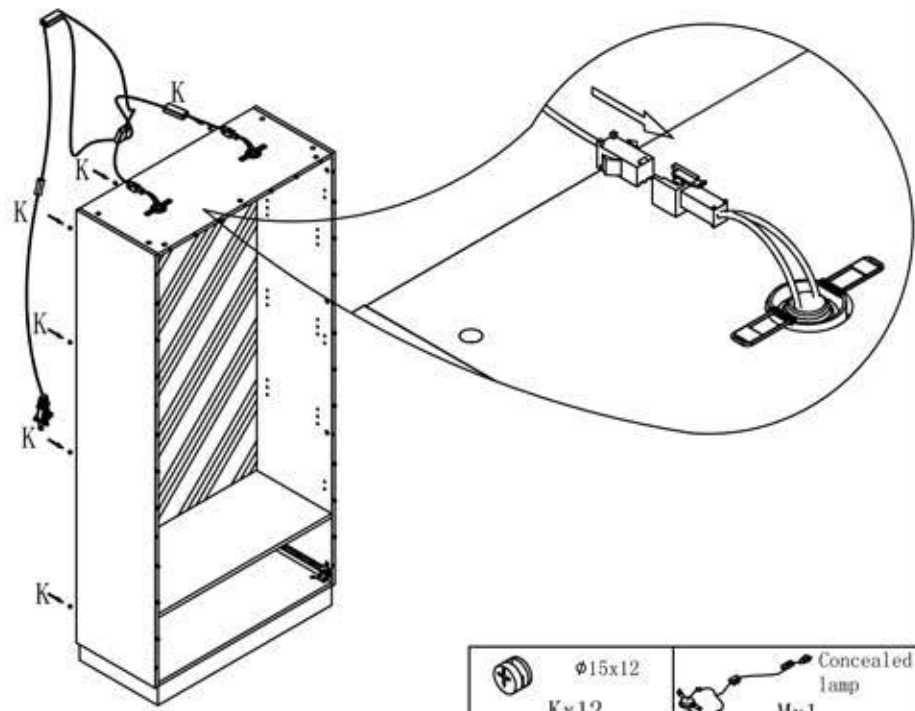

- | | | | |
|--|--------|--|----------------|
| | φ15x12 | | Concealed lamp |
| | Kx12 | | Mx1 |

STEP6

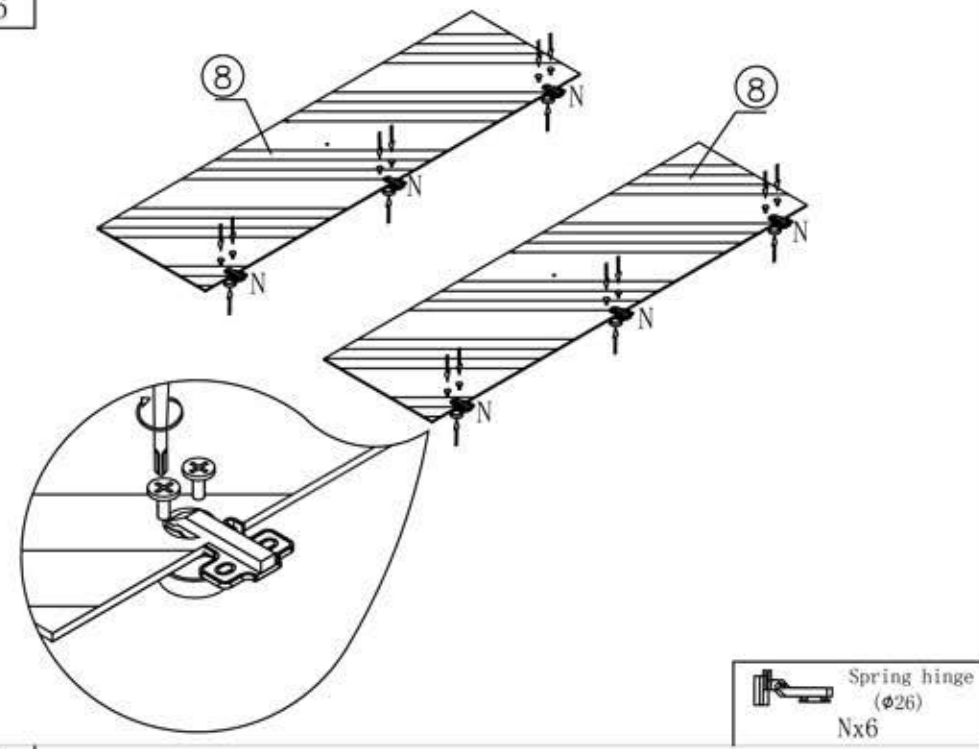

- | | |
|--|--------------------|
| | Spring hinge (φ26) |
| | Nx6 |

STEP7

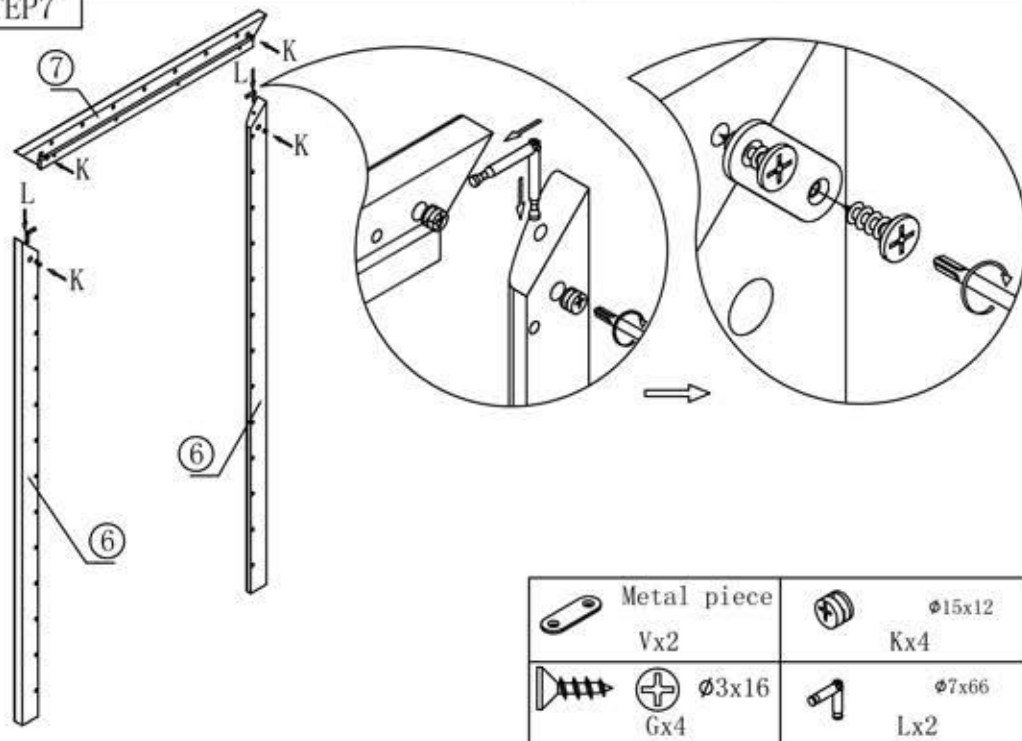

- | | | | |
|--|-------------|--|--------|
| | Metal piece | | φ15x12 |
| | Vx2 | | Kx4 |
| | φ3x16 | | φ7x66 |
| | Gx4 | | Lx2 |

STEP8

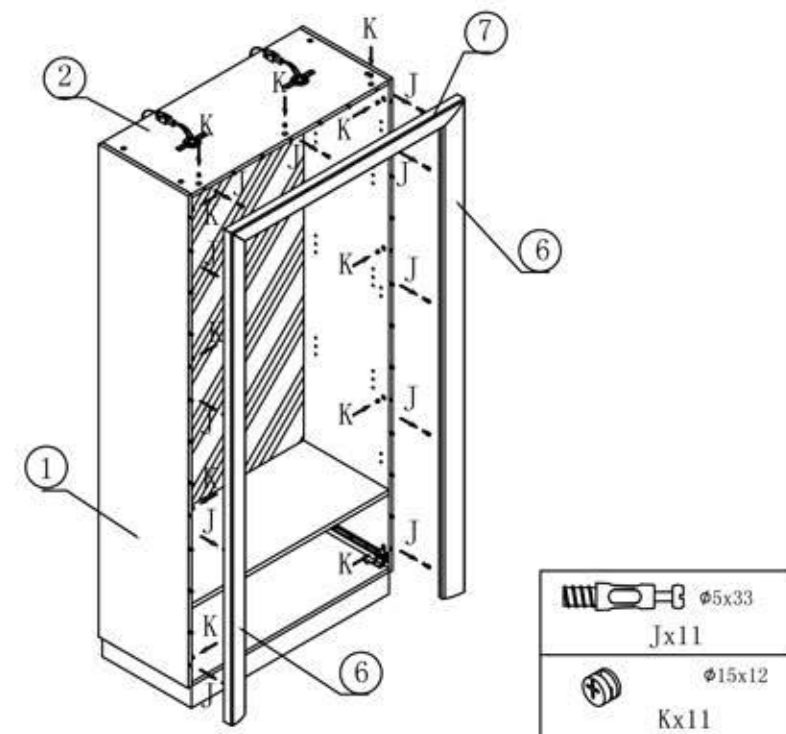

- | | |
|--|--------|
| | φ5x33 |
| | Jx11 |
| | φ15x12 |
| | Kx11 |

VITRINE

STEP9

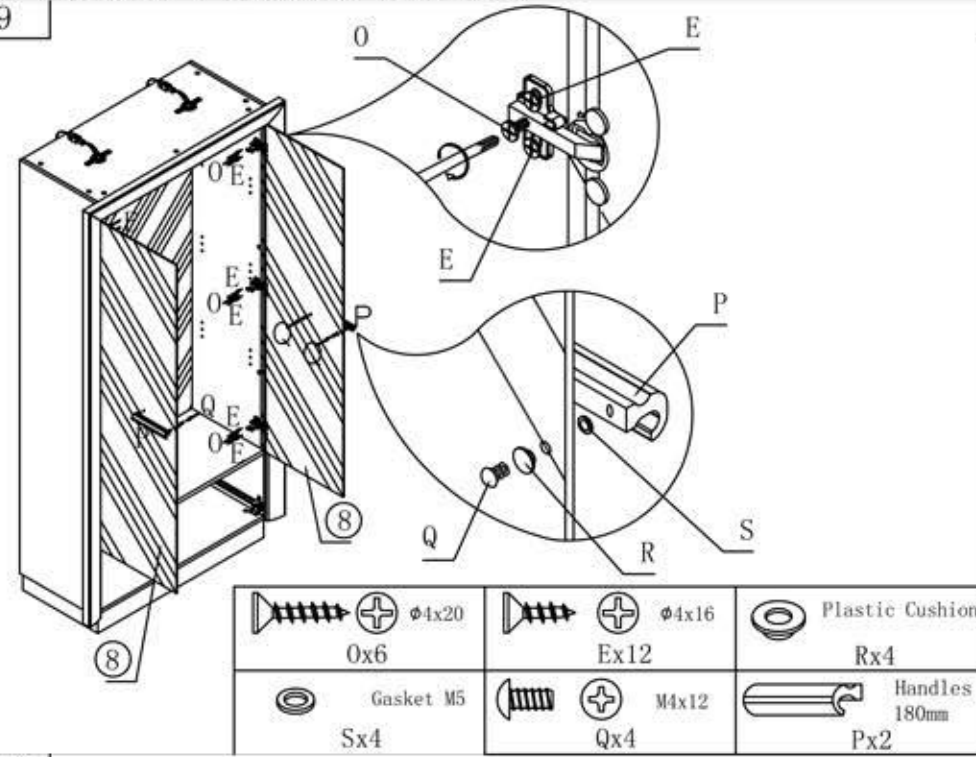

STEP11

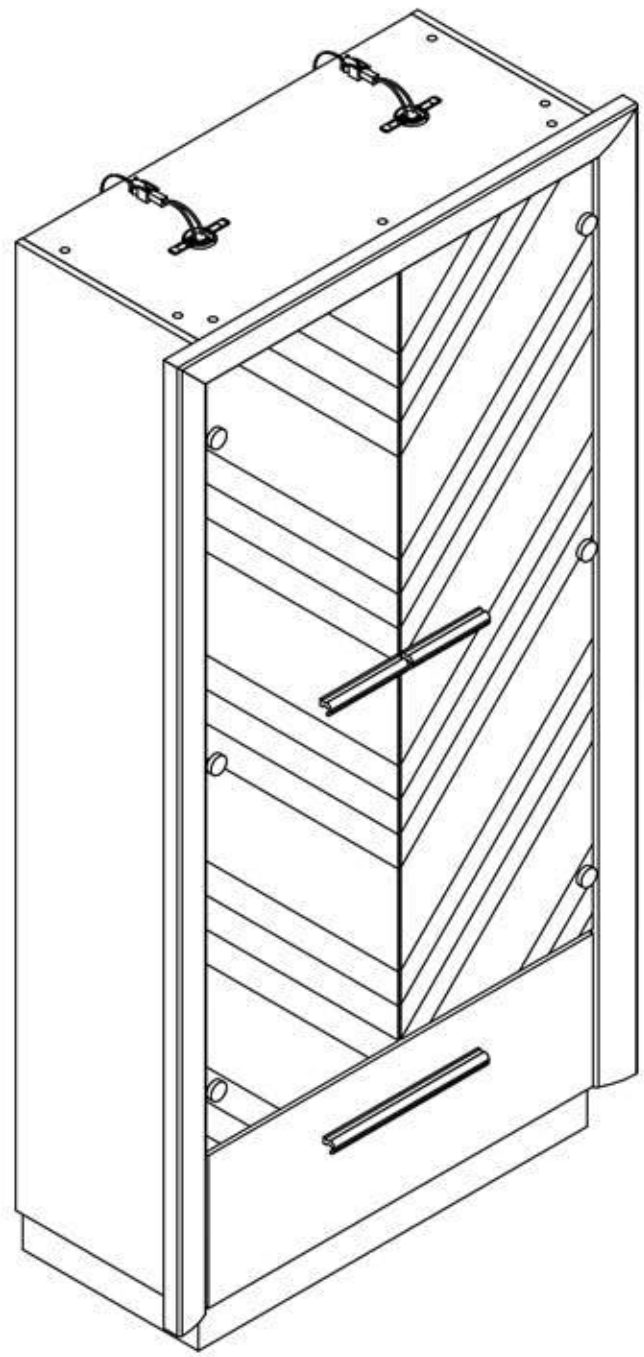

STEP10

