

Assembly Instruction (WLF-C19)

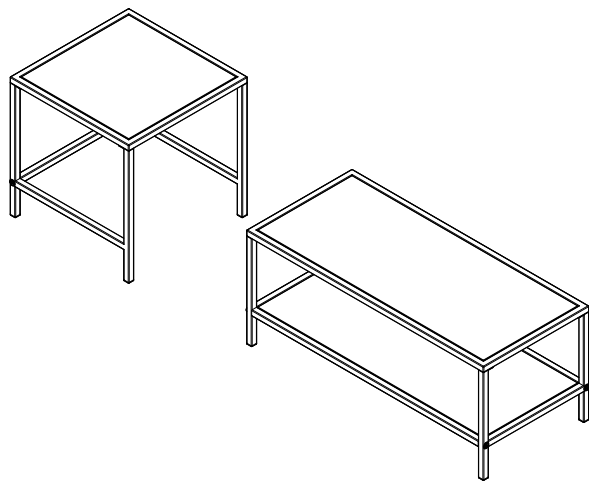

Parts List

Open the hardware check all parts QTY, thanks

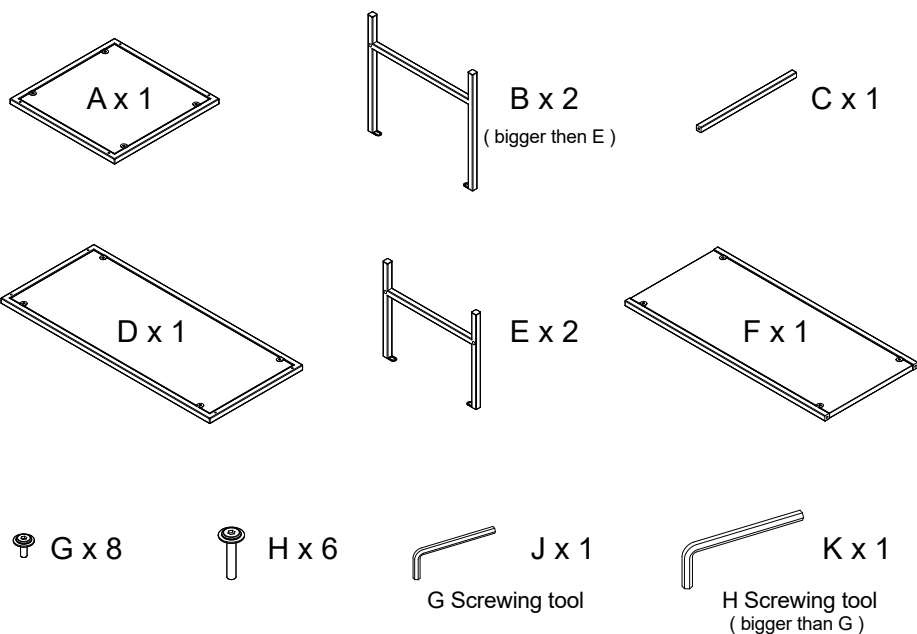

Step 1

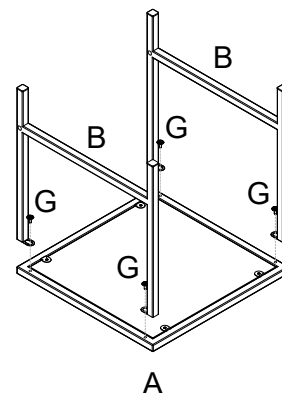
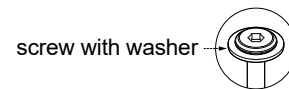

! The screw must be loose to finish

Step 2

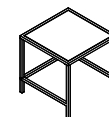
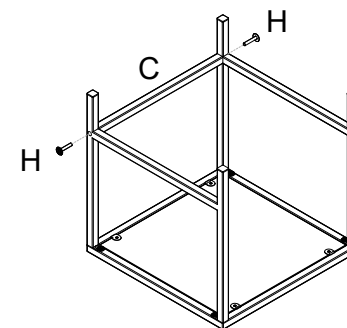
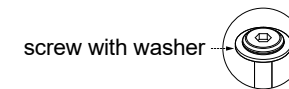

Tighten all screws and turn it over to finish

Step 3

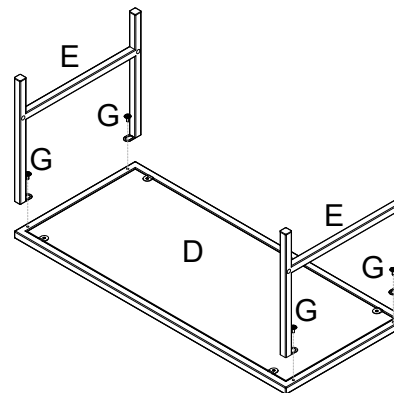
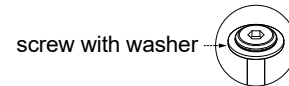

! The screw must be loose to finish

Step 4

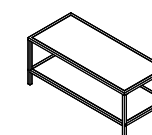
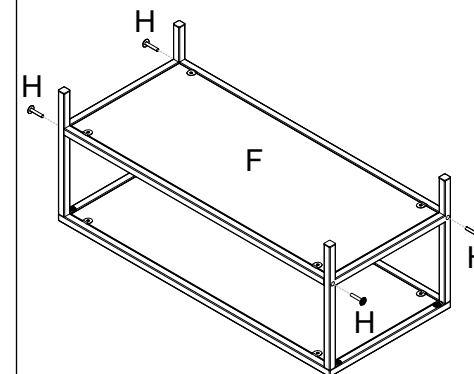
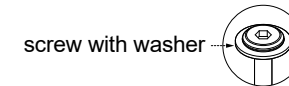

Tighten all screws and turn it over to finish