

EMC Test Report



**Add value.
Inspire trust.**

Applicant: GD Midea Air-Conditioning Equipment Co., Ltd.



Address: Lingang Road, Beijiao, Shunde 528311 Foshan, Guangdong, PEOPLE'S REPUBLIC OF CHINA.

Product: Air dehumidifier (Dehumidifier)

Models: MDDO-12DEN7-QA3;
(Other models refer to section 1.2)

COMMERCIAL-IN-CONFIDENCE

Report Number: 64.911.24.00149.01-E

RESPONSIBLE FOR	NAME	SIGNATURE	DATE
Prepared by	Tim Yue		2024-10-09
Approved by	Kevin Ouyang		2024-10-09

Signatures in this approval box have checked this document in line with the requirements of TÜV SÜD Product Service control rules.

<p>EXECUTIVE SUMMARY This product was tested and found to be in compliance with</p>	<p>EN IEC 55014-1:2021 EN IEC 55014-2:2021 EN IEC 61000-3-2:2019+A1:2021 EN 61000-3-3:2013+A1:2019+A2:2021 EN 301 489-1 V2.2.3:2019 EN 301 489-17 V3.2.4:2020</p>
--	---



Contents

1	Report Summary	3
1.1	Report Modification Record	3
1.2	Introduction	3
1.3	Brief Summary of Results	4
1.4	Test Conditions	5
1.5	Product Information and general remarks	7
1.6	Deviations from the Standard	7
1.7	Test Location	7
2	Test Details.....	7
2.1	Conducted Disturbance at Mains Terminals.....	8
2.2	Discontinuous disturbances.....	18
2.3	Magnetic field induced current.....	22
2.4	Disturbance power.....	24
2.5	Radiated Disturbance (30MHz to 6000MHz).....	26
2.6	Harmonic current emission.....	45
2.7	Flicker	51
2.8	Electrostatic discharge immunity test	55
2.9	Electrical fast transient /burst immunity test	58
2.10	Immunity to conducted disturbances, induced by radio-frequency fields.....	61
2.11	Radiated, radio-frequency, electromagnetic field immunity test.....	64
2.12	Surge immunity test.....	66
2.13	Voltage dips, short interruptions and voltage variations immunity tests.....	68
3	Test Equipment Information	70
3.1	General Test Equipment Used	70
4	Measurement Uncertainty.....	72
5	Photographs.....	74

1 Report Summary

1.1 Report Modification Record

Alterations and additions to this report will be issued to the holders of each copy in the form of a complete document.

Issue	Description of Change	Date of Issue
1	First Issue	2024-10-09

1.2 Introduction

Any use for advertising purposes must be granted in writing. This technical report may only be quoted in full. This report is the result of a single examination of the object in question and is not generally applicable evaluation of the quality of other products in regular production. For further details please see testing and certification regulation, chapter A-3.4.

The information contained in this report is intended to show verification of the EMC Qualification Approval Testing of the requirements of the standards for the tests listed in Section 1.3.

Applicant	: GD Midea Air-Conditioning Equipment Co., Ltd.
Address	: Lingang Road, Beijiao, Shunde 528311 Foshan, Guangdong, PEOPLE'S REPUBLIC OF CHINA.
Manufacturer	: GD Midea Air-Conditioning Equipment Co., Ltd.
Address	: Lingang Road, Beijiao, Shunde 528311 Foshan, Guangdong, PEOPLE'S REPUBLIC OF CHINA.
Model Number(s)	: MDDO-10DEN7-QA3, MDDO1-10DEN7-QA3, MDDO2-10DEN7-QA3, MDDO3-10DEN7-QA3, MDDO-12DEN7-QA3, MDDO1-12DEN7-QA3, MDDO2-12DEN7-QA3, MDDO3-12DEN7-QA3
Product Type	: Air dehumidifier (Dehumidifier)
Trademark	: Midea
Date of Receipt of EUT	: 2024-06-15
Start of Test	: 2024-06-17
Finish of Test	: 2024-09-09
Name of Engineer(s)	: Tim Yue

1.3 Brief Summary of Results

A brief summary of the tests carried out in accordance with EN IEC 55014-1, EN IEC 61000-3-2, EN 61000-3-3, EN IEC 55014-2, EN 301 489-1, EN 301 489-17 is shown below.

Summary of results				
Test Items	Test Configuration & Test Mode	Required Performance Criteria	Result	Test site
<u>Radiated Emissions Enclosure Port</u>	TC1/TM1	EN 301 489-1 & EN IEC 55014-1	Pass	Site 2
<u>Conducted emission</u>	TC1/TM1	EN 301 489-1 & EN IEC 55014-1	Pass	Site 1
<u>Disturbance Power*</u>	TC1/TM1	EN IEC 55014-1	N/A	N/A
<u>Clicks</u>	TC1/TM1	EN IEC 55014-1	Pass	Site 1
<u>Current harmonics emissions</u>	TC1/TM1	EN IEC 61000-3-2	Pass	Site 1
<u>Voltage fluctuations and flickers</u>	TC1/TM1	EN 61000-3-3	Pass	Site 1
<u>Immunity To Electrostatic Discharge Enclosure Port</u>	TC1/TM1	EN 301 489-1 & EN IEC 55014-2	Pass	Site 1
<u>Immunity To Radiated Electromagnetic Fields Enclosure Port</u>	TC1/TM1	EN 301 489-1	Pass	Site 2
<u>Immunity To Electrical Fast Transient Bursts</u>	TC1/TM1	EN 301 489-1 & EN IEC 55014-2	Pass	Site 1
<u>Immunity To Surges</u>	TC1/TM1	EN 301 489-1 & EN IEC 55014-2	Pass	Site 1
<u>Immunity To Continuous Conducted Interference</u>	TC1/TM1	EN 301 489-1 & EN IEC 55014-2	Pass	Site 1
<u>Immunity To Continuous Voltage dips and Short Interruption</u>	TC1/TM1	EN 301 489-1 & EN IEC 55014-2	Pass	Site 1

Note:

- 1, Measurement taken is within the measurement uncertainty of measurement system.
- 2, TC = Test configuration
3. Note***: The EUT was tested for emissions in the frequency from 30MHz to 1000MHz with Radiated disturbance test method, it is also deemed to comply the disturbance power method test in the frequency range from 30MHz to 300MHz.



1.4 Test Conditions

1.4.1 Environmental Conditions

<p>The climatic conditions during the tests are within the limits specified by the manufacturer for the operation of the EUT and the test equipment.</p> <p>The climatic conditions during the tests were within the following limits:</p>		
Temperature	Humidity	Atmospheric pressure
15 °C – 35 °C	30 % - 60 %	860 hPa – 1060 hPa
<p>If explicitly required in the basic standard or applied product standard the climatic values are recorded and documented separately in this test report.</p>		

1.4.2 Performance Criteria

Clause 4 of EN IEC 55014-2		
Criteria	During test	After test
A	The apparatus shall continue to operate as intended during the test. No degradation of performance or loss of function is allowed below a performance level specified by the manufacturer, when the apparatus is used as intended. If the minimum performance level or the permissible performance loss is not specified by the manufacturer, then either of these may be derived from the product description and documentation, and from what the user may reasonable expect from the apparatus if used as intended.	
B	The apparatus shall continue to operate as intended after the test. No degradation of performance or loss of function is allowed below a performance level specified by the manufacturer, when the apparatus is used as intended. During the test, degradation of performance is allowed, however no change of actual operating state or stored data is allowed to persist after test. If the minimum performance level or the permissible performance loss is not specified by the manufacturer, then either of these may be derived from the product description and documentation, and from what the user may reasonable expect from the apparatus if used as intended.	
C	Temporary loss of function is allowed, provided the function is self-recoverable or can be restored by the operation of the controls, or by any operation specified in the instruction for use.	

Clause 6 of EN301 489-1	
Criteria	Performance Criteria
CT/CR	During and after the test, the apparatus shall continue to operate as intended. No degradation of performance or loss of function is allowed below a permissible performance level specified by the manufacturer when the apparatus is used as intended.
TT/TR	After the test, the apparatus shall continue to operate as intended. No degradation of performance or loss of function is allowed below a permissible performance level specified by the manufacturer, when the apparatus is used as intended.



Clause 6 of EN301 489-17		
Criteria	During test	After test
A	Shall operate as intended. (see note 1). Shall be no loss of function. Shall be no unintentional transmissions.	Shall operate as intended. Shall be no degradation of performance (see note 3). Shall be no loss of function. Shall be no loss of stored data or user programmable functions.
B	May show loss of function (one or more). May show degradation of performance (see note 2). Shall be no unintentional transmissions.	Functions shall be self-recoverable. Shall operate as intended after recovering. Shall be no degradation of performance (see note 3). Shall be no loss of stored data or user programmable functions.
C	May be loss of function (one or more).	Functions shall be recoverable by the operator. Shall operate as intended after recovering. Shall be no degradation of performance (see note 3).
NOTE 1:	Operate as intended during the test allows a level of degradation not below a minimum performance level specified by the manufacturer for the use of the apparatus as intended. In some cases the specified minimum performance level may be replaced by a permissible degradation of performance. If the minimum performance level or the permissible performance degradation is not specified by the manufacturer then either of these may be derived from the product description and documentation (including leaflets and advertising) and what the user may reasonably expect from the apparatus if used as intended.	
NOTE 2:	Degradation of performance during the test is understood as a degradation to a level not below a minimum performance level specified by the manufacturer for the use of the apparatus as intended. In some cases the specified minimum performance level may be replaced by a permissible degradation of performance. If the minimum performance level or the permissible performance degradation is not specified by the manufacturer then either of these may be derived from the product description and documentation (including leaflets and advertising) and what the user may reasonably expect from the apparatus if used as intended.	
NOTE 3:	No degradation of performance after the test is understood as no degradation below a minimum performance level specified by the manufacturer for the use of the apparatus as intended. In some cases the specified minimum performance level may be replaced by a permissible degradation of performance. After the test no change of actual operating data or user retrievable data is allowed. If the minimum performance level or the permissible performance degradation is not specified by the manufacturer then either of these may be derived from the product description and documentation (including leaflets and advertising) and what the user may reasonably expect from the apparatus if used as intended.	

1.5 Product Information and general remarks

1.5.1 Technical Description

Ratings : 220-240V~, 50Hz, 300W,1.5A
Protection class : Class I

1.5.2 Test Configuration

Configuration	Description
TC1	230V~, 50Hz

1.5.3 Modes of Operation

Mode	Description
TM1	Dehumidifier + WIFI & BLE Link

1.5.4 General remark:

EUT is a kind of Air dehumidifier (Dehumidifier) with an optional wireless module, the wireless module support 2.4G Wi-Fi and BLE function.

MDDO1-12DEN7-QA3 is same as MDDO-12DEN7-QA3 except the display board and appearance.

MDDO-10DEN7-QA3, MDDO1-10DEN7-QA3 are respectively same as the MDDO-12DEN7-QA3, MDDO1-12DEN7-QA3 except the compressor, evaporator and condenser.

MDDO3-10DEN7-QA3 is same as MDDO-10DEN7-QA3 except the appearance of display panel;
MDDO2-10DEN7-QA3 is same as MDDO1-10DEN7-QA3 except the appearance of display panel;
MDDO3-12DEN7-QA3 is same as MDDO-12DEN7-QA3 except the appearance of display panel;
MDDO2-12DEN7-QA3 is same as MDDO1-12DEN7-QA3 except the appearance of display panel.

Added alternative fan motor for all models.

By evaluation, MDDO1-12DEN7-QA3 was select to perform full test; MDDO-12DEN7-QA3 with alternative fan motor was select to perform test CE, RE, RS, EFT, ESD and CS; MDDO-10DEN7-QA3 were select to perform EMI test, MDDO1-10DEN7-QA3 was select to perform test CE, RE.

1.6 Deviations from the Standard

No deviations from the applicable test standard were made during testing.

1.7 Test Location

Test Site 1:

Test Center of Guangdong Midea Air-Conditioning Equipment Co., Ltd

Address:

Midea Industrial Zone, Shunde District, Foshan, Guangdong, China

Test Site 2:

TÜV SÜD Certification and Testing (China) Co., Ltd. Guangzhou Branch

Address:

D1 Buildings, No. 63 Chuangqi Road, Shilou Town, Panyu District, Guangzhou, China

2 Test Details

2.1 Conducted Disturbance at Mains Terminals

2.1.1 Test Method

The EUT was placed on a 0.8 m non-conductive table for table-top equipment and on a 0.12 m insulated support for floor standing equipment above a ground reference plane all within a test laboratory.

All power was connected to the EUT through an Artificial Mains Network (AMN). Conducted disturbance voltage measurements on mains lines were made at the output of the AMN. The AMN was placed 0.8m from the boundary of the EUT and bonded to the reference ground plane.

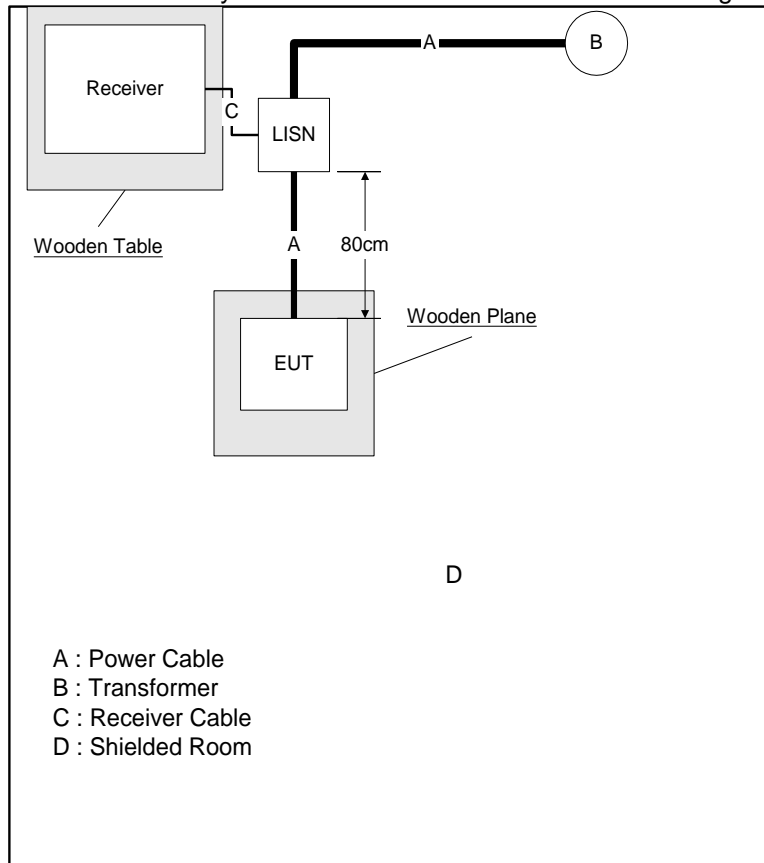

2.1.2 Specification Limits

EN IEC 55014-1

Household appliances and equipment causing similar disturbances and regulating controls incorporating semiconductor devices				
Frequency range	At main terminals dB(μV)		At load terminals and additional terminals dB(μV)	
	Quasi-peak	Average	Quasi-peak	Average
0.15 to 0.5	66 to 56	59 to 46	80	70
0.5 to 5	56	46	74	64
5 to 30	60	50	74	64

EN 55032

Household appliances and equipment causing similar disturbances and regulating controls incorporating semiconductor devices		
Frequency range	At main terminals dB(μV)	
MHz	Quasi-peak	Average
0.15 to 0.5	66 to 56	56 to 46
0.5 to 5	56	46
5 to 30	60	50

Remark for test data:

*Level=Reading Level + Correction Factor

**Correction Factor=Cable Loss + LISN Factor

(The Reading Level is recorded by software which is not shown in the sheet)

2.1.3 Test Setup



2.1.4 Test Location

This test was carried out in shielded room.



2.1.5 Test Results

Data show limits as EN IEC 55014-1, according to an evaluation, data also complies within EN 55032.

Model : MDDO1-12DEN7-QA3
 Test Mode : TM1
 Test Voltage : 230V~, 50Hz
 Remark : AC Mains, line L1
 Test Date : 2024-07-13

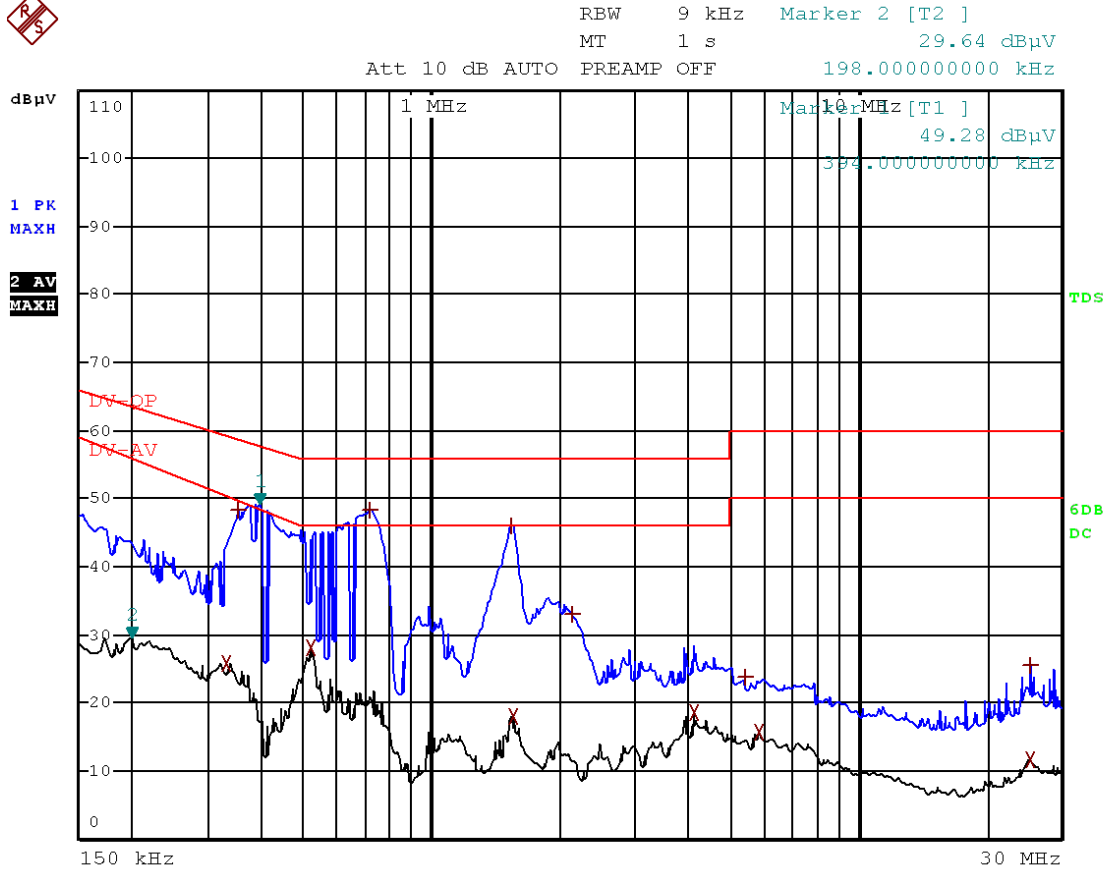

EDIT PEAK LIST (Final Measurement Results)

Trace1: DV-QP
 Trace2: DV-AV
 Trace3: ---

TRACE	FREQUENCY	LEVEL dBμV	DELTA LIMIT dB
1 Quasi Peak	718 kHz	40.69	-15.30
1 Quasi Peak	1.542 MHz	38.58	-17.41
2 Average	522 kHz	27.36	-18.63
1 Quasi Peak	350 kHz	39.31	-19.65
2 Average	334 kHz	24.91	-25.44
2 Average	4.15 MHz	16.45	-29.54
2 Average	1.558 MHz	15.02	-30.98
1 Quasi Peak	2.13 MHz	24.94	-31.05
2 Average	5.878 MHz	13.35	-36.64
2 Average	25.314 MHz	10.36	-39.63
1 Quasi Peak	5.454 MHz	18.30	-41.69
1 Quasi Peak	25.314 MHz	15.38	-44.61



Model : MDD01-12DEN7-QA3
 Test Mode : TM1
 Test Voltage : 230V~, 50Hz
 Remark : AC Mains, line N
 Test Date : 2024-07-13

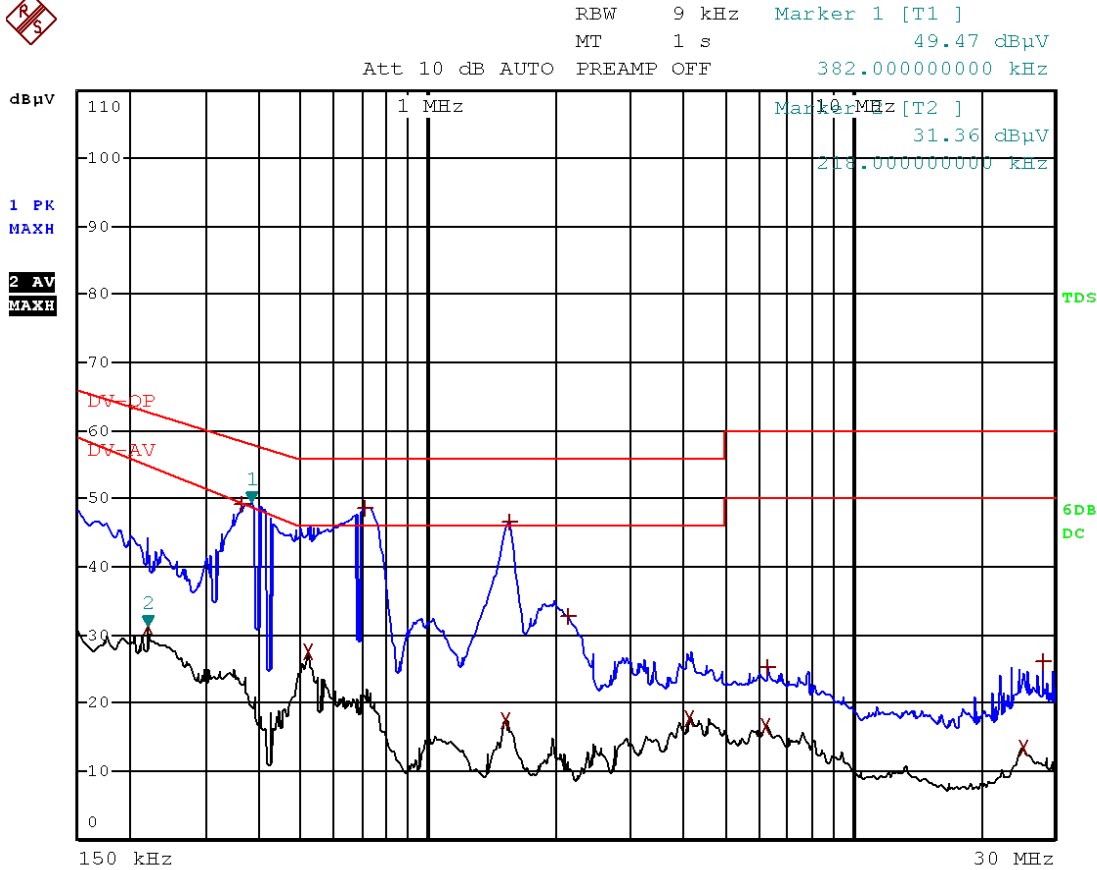

EDIT PEAK LIST (Final Measurement Results)

Trace1: DV-QP
 Trace2: DV-AV
 Trace3: ---

TRACE	FREQUENCY	LEVEL dBμV	DELTA LIMIT dB
1 Quasi Peak	710 kHz	41.15	-14.84
1 Quasi Peak	1.554 MHz	38.68	-17.32
1 Quasi Peak	362 kHz	40.72	-17.95
2 Average	522 kHz	25.98	-20.01
2 Average	218 kHz	28.69	-26.27
2 Average	4.138 MHz	15.79	-30.20
1 Quasi Peak	2.13 MHz	25.00	-30.99
2 Average	1.522 MHz	14.20	-31.79
2 Average	6.222 MHz	14.59	-35.40
2 Average	25.338 MHz	11.83	-38.16
1 Quasi Peak	6.346 MHz	19.76	-40.23
1 Quasi Peak	28.278 MHz	15.46	-44.53



Model : MDDO-12DEN7-QA3
 Test Mode : TM1
 Test Voltage : 230V~, 50Hz
 Remark : AC Mains, line L1
 Test Date : 2024-07-08

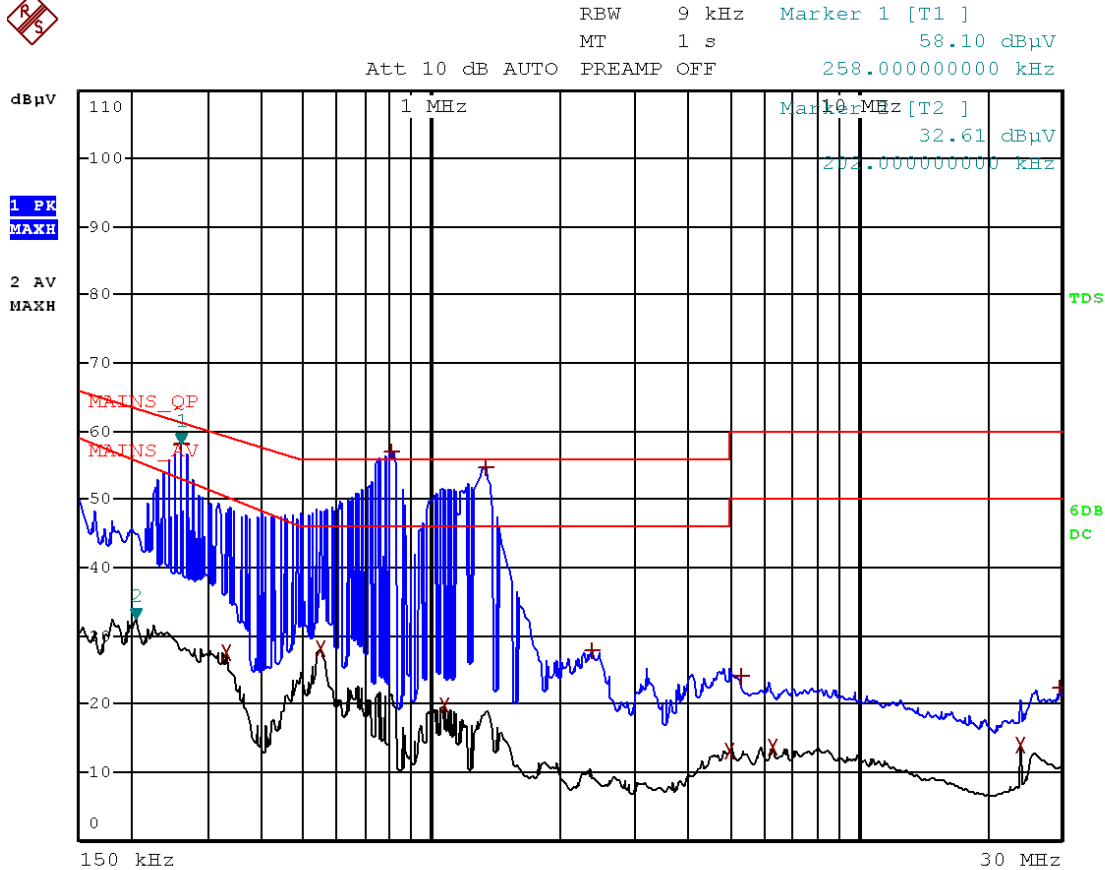

EDIT PEAK LIST (Final Measurement Results)

Trace1: MAINS_QP
 Trace2: MAINS_AV
 Trace3: ---

TRACE	FREQUENCY	LEVEL dBµV	DELTA LIMIT dB
1 Quasi Peak	802 kHz	46.71	-9.28
1 Quasi Peak	1.338 MHz	44.27	-11.72
1 Quasi Peak	258 kHz	45.75	-15.74
2 Average	550 kHz	28.05	-17.94
2 Average	330 kHz	25.78	-24.70
2 Average	1.078 MHz	17.24	-28.75
2 Average	4.982 MHz	11.70	-34.29
2 Average	24.026 MHz	13.20	-36.79
2 Average	6.342 MHz	12.33	-37.66
1 Quasi Peak	2.374 MHz	16.90	-39.09
1 Quasi Peak	5.346 MHz	17.26	-42.73
1 Quasi Peak	29.55 MHz	16.27	-43.72



Model : MDDO-12DEN7-QA3
 Test Mode : TM1
 Test Voltage : 230V~, 50Hz
 Remark : AC Mains, line N
 Test Date : 2024-07-08

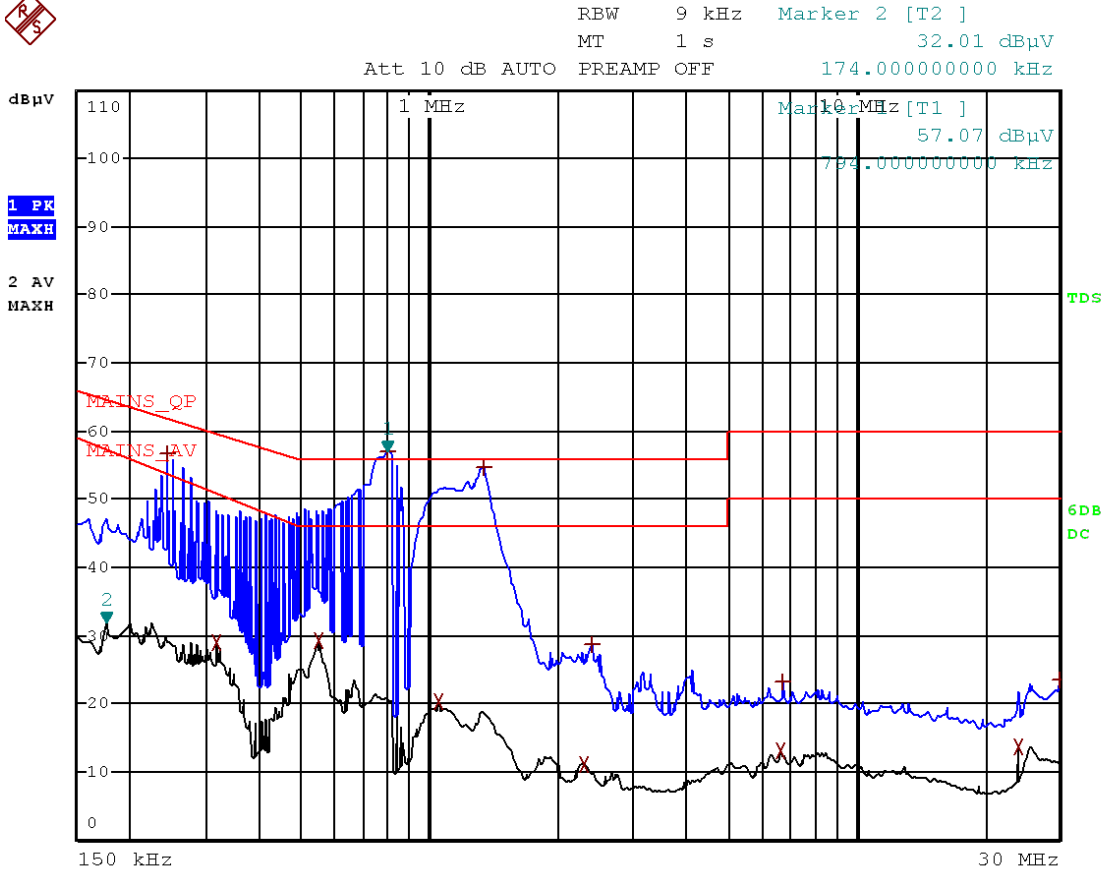

EDIT PEAK LIST (Final Measurement Results)

Trace1: MAINS_QP
 Trace2: MAINS_AV
 Trace3: ---

TRACE	FREQUENCY	LEVEL dBµV	DELTA LIMIT dB
1 Quasi Peak	794 kHz	46.60	-9.39
1 Quasi Peak	1.338 MHz	44.40	-11.59
1 Quasi Peak	242 kHz	44.91	-17.10
2 Average	550 kHz	28.49	-17.50
2 Average	314 kHz	26.72	-24.30
2 Average	1.05 MHz	16.86	-29.13
2 Average	2.306 MHz	9.98	-36.01
2 Average	24.026 MHz	13.34	-36.66
2 Average	6.682 MHz	11.88	-38.11
1 Quasi Peak	2.41 MHz	16.71	-39.28
1 Quasi Peak	29.886 MHz	17.52	-42.47
1 Quasi Peak	6.714 MHz	17.00	-42.99



Model : MDDO1-10DEN7-QA3
 Test Mode : TM1
 Test Voltage : 230V~, 50Hz
 Remark : AC Mains, line L1
 Test Date : 2024-08-13

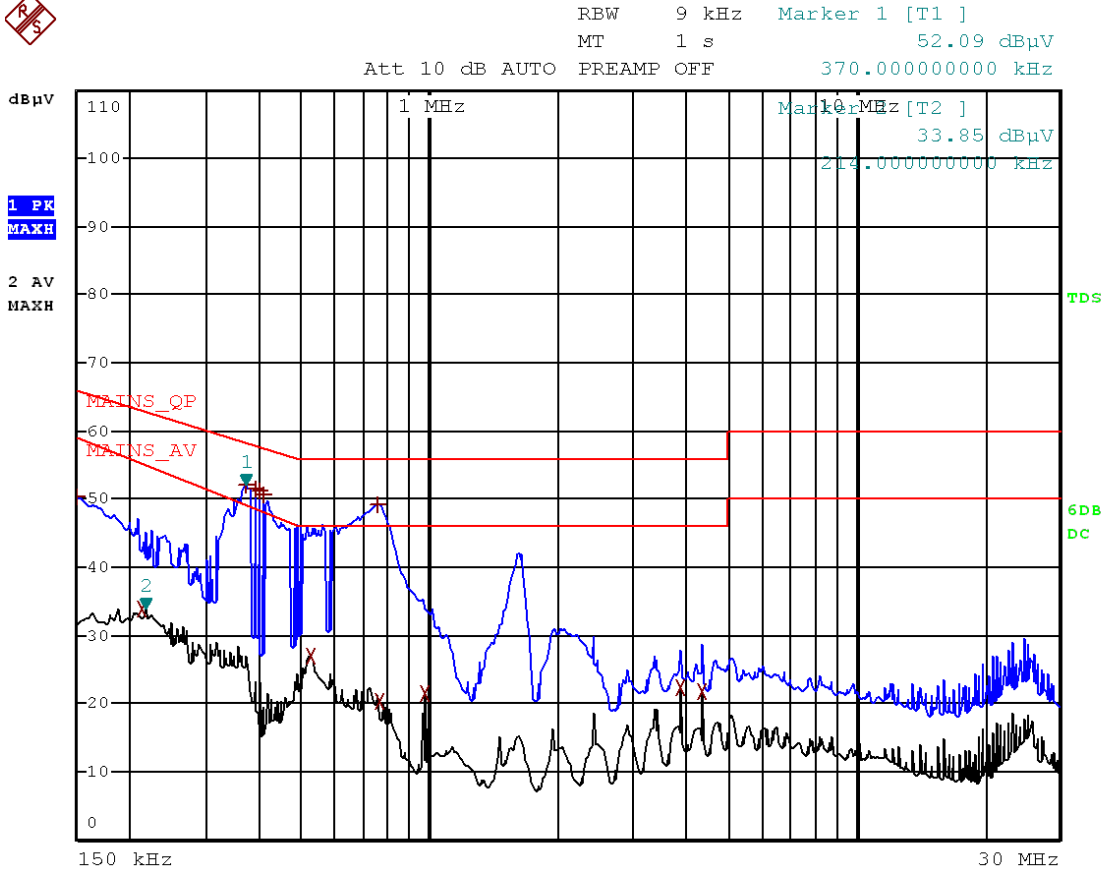

EDIT PEAK LIST (Final Measurement Results)

Trace1: MAINS_QP
 Trace2: MAINS_AV
 Trace3: ---

TRACE	FREQUENCY	LEVEL dBµV	DELTA LIMIT dB
1 Quasi Peak	390 kHz	42.29	-15.76
1 Quasi Peak	398 kHz	41.88	-16.01
1 Quasi Peak	406 kHz	41.42	-16.31
1 Quasi Peak	370 kHz	42.03	-16.46
1 Quasi Peak	758 kHz	37.61	-18.38
2 Average	526 kHz	26.72	-19.27
1 Quasi Peak	150 kHz	45.75	-20.25
2 Average	214 kHz	31.84	-23.32
2 Average	3.882 MHz	20.22	-25.77
2 Average	970 kHz	19.95	-26.04
2 Average	4.366 MHz	19.89	-26.10
2 Average	766 kHz	16.11	-29.88



Model : MDDO1-10DEN7-QA3
 Test Mode : TM1
 Test Voltage : 230V~, 50Hz
 Remark : AC Mains, line N
 Test Date : 2024-08-13

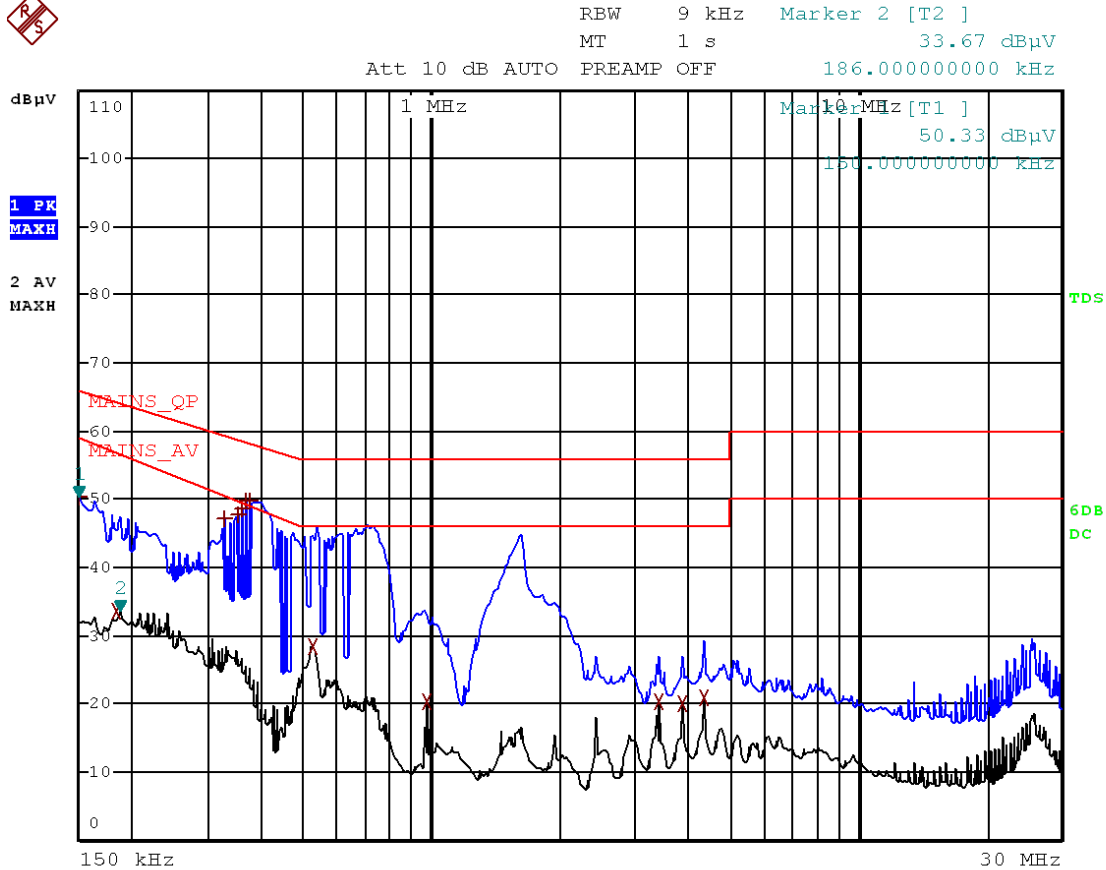

EDIT PEAK LIST (Final Measurement Results)

Trace1: MAINS_QP
 Trace2: MAINS_AV
 Trace3: ---

TRACE	FREQUENCY	LEVEL dBμV	DELTA LIMIT dB
1 Quasi Peak	374 kHz	42.43	-15.97
1 Quasi Peak	366 kHz	42.13	-16.45
1 Quasi Peak	358 kHz	41.60	-17.16
2 Average	526 kHz	28.43	-17.56
1 Quasi Peak	350 kHz	40.98	-17.97
1 Quasi Peak	150 kHz	45.49	-20.50
1 Quasi Peak	326 kHz	38.13	-21.42
2 Average	186 kHz	31.34	-25.33
2 Average	970 kHz	20.27	-25.72
2 Average	3.882 MHz	20.11	-25.89
2 Average	3.398 MHz	19.09	-26.90
2 Average	4.37 MHz	19.02	-26.97



Model : MDDO-10DEN7-QA3
 Test Mode : TM1
 Test Voltage : 230V~, 50Hz
 Remark : AC Mains, line L1
 Test Date : 2024-07-19

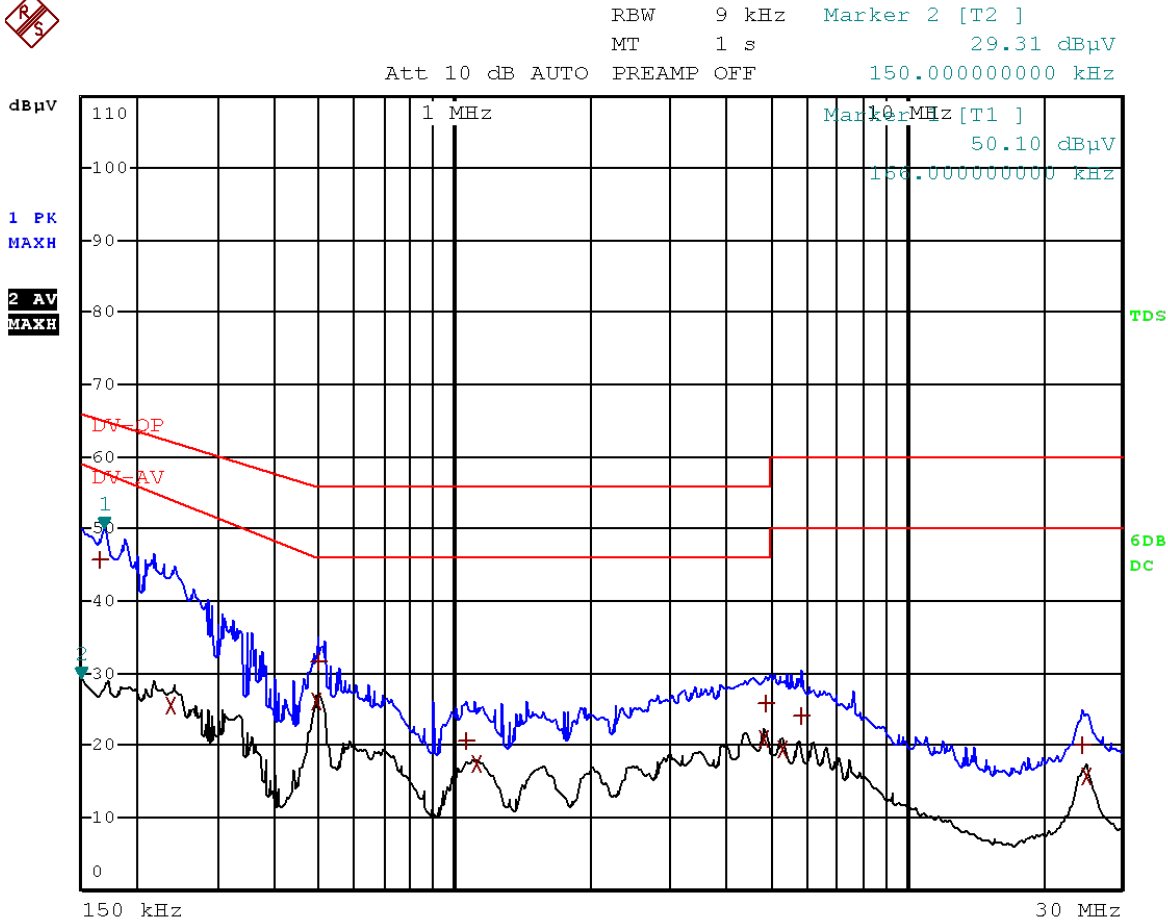

EDIT PEAK LIST (Final Measurement Results)

TRACE	FREQUENCY	LEVEL dBµV	DELTA LIMIT dB
Trace1: DV-QP			
Trace2: DV-AV			
Trace3: ---			
1 Quasi Peak	166 kHz	45.83	-19.32
2 Average	494 kHz	26.16	-19.97
1 Quasi Peak	498 kHz	31.64	-24.38
2 Average	4.822 MHz	20.89	-25.10
2 Average	1.118 MHz	17.50	-28.50
2 Average	238 kHz	25.49	-28.52
1 Quasi Peak	4.886 MHz	25.92	-30.07
2 Average	5.342 MHz	19.48	-30.51
2 Average	25.162 MHz	15.84	-34.15
1 Quasi Peak	1.058 MHz	20.72	-35.27
1 Quasi Peak	5.838 MHz	24.16	-35.83
1 Quasi Peak	24.61 MHz	20.00	-39.99



Model : MDDO-10DEN7-QA3
 Test Mode : TM1
 Test Voltage : 230V~, 50Hz
 Remark : AC Mains, line N
 Test Date : 2024-07-19



REBW 9 kHz Marker 2 [T2]
 MT 1 s 31.44 dBµV
 Att 10 dB AUTO PREAMP OFF 166.000000000 kHz

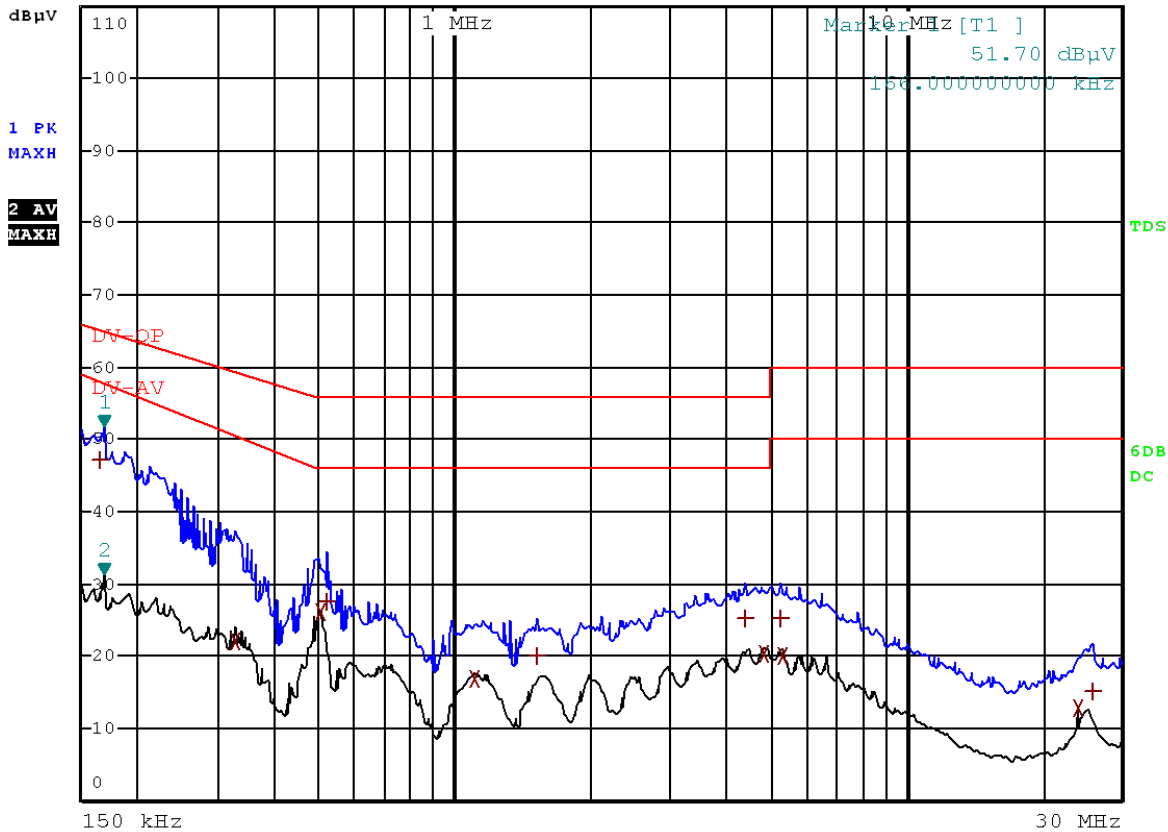

EDIT PEAK LIST (Final Measurement Results)

TRACE	FREQUENCY	LEVEL dBµV	DELTA LIMIT dB
Trace1: DV-QP			
Trace2: DV-AV			
Trace3: ---			
1 Quasi Peak	166 kHz	47.18	-17.97
2 Average	502 kHz	26.10	-19.89
2 Average	4.838 MHz	20.49	-25.50
1 Quasi Peak	518 kHz	27.64	-28.35
2 Average	326 kHz	21.94	-28.67
2 Average	1.106 MHz	16.85	-29.14
2 Average	5.322 MHz	19.95	-30.04
1 Quasi Peak	4.394 MHz	25.32	-30.67
1 Quasi Peak	5.258 MHz	25.28	-34.71
1 Quasi Peak	1.518 MHz	20.05	-35.94
2 Average	24.01 MHz	12.98	-37.01
1 Quasi Peak	25.838 MHz	15.13	-44.86

2.2 Discontinuous disturbances

2.2.1 Test Method

All power was connected to the EUT through an Artificial Mains Network (AMN). Conducted disturbance voltage measurements on mains lines were made at the output of the AMN. An initial measurement was made in an observation period of 120 minutes, or the time to register 40 clicks. The clicks obtained was compared against the corresponding click limit L_q for the required 4 individual frequencies. The test was repeated in similar period as the initial measurement. The number of clicks during the second measurement should not exceed a quarter of that measured during the initial measurement.

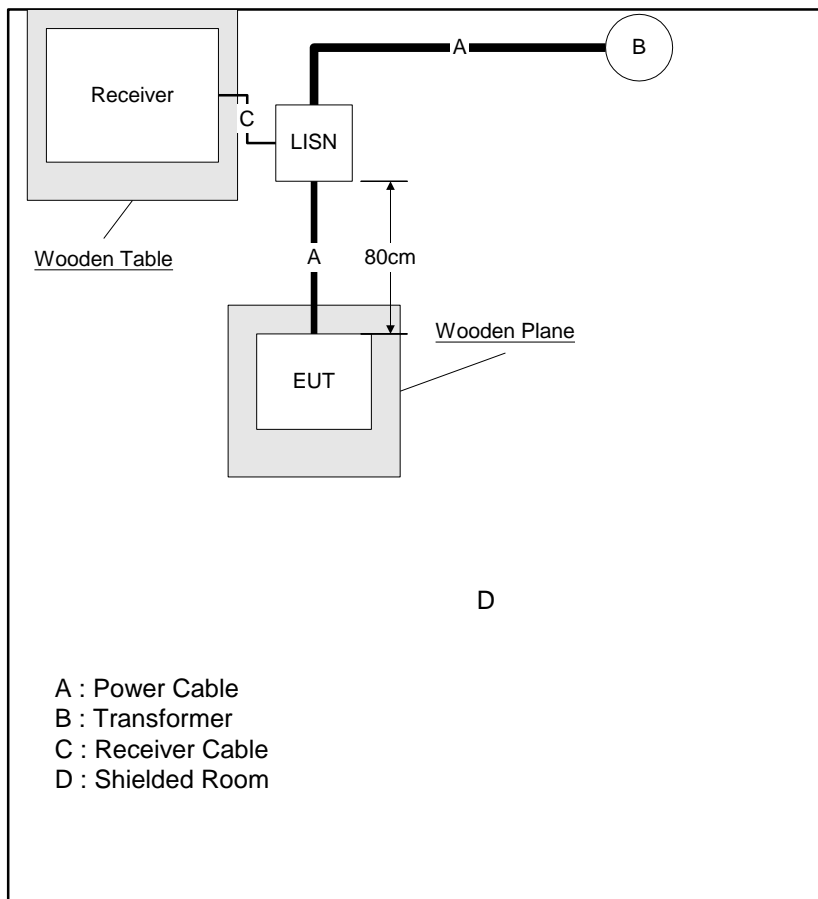

2.2.2 Specification Limits

Frequency Range (MHz)	Discontinuous disturbances limits (dB μ V)	
	N < 0.2	0.2 \le N < 30
0.15	110dB μ V	66dB μ V + 20 log (30/N)
0.5	100dB μ V	56dB μ V + 20 log (30/N)
1.4	100dB μ V	56dB μ V + 20 log (30/N)
30	104dB μ V	60dB μ V + 20 log (30/N)

Note: N refers to click rate

2.2.3 Test Setup



2.2.4 Test Location

This test was carried out in shielded room.



2.2.5 Test Results

Model : MDDO1-12DEN7-QA3
 Test mode : TM1
 Test voltage : 230VAC, 50Hz
 Test specification : AC mains
 Test date : 2024-07-13

Frequency	150kHz	500kHz	1.4MHz	30MHz
Limit value (L)(dB/uV)	66	56	56	60
Amount of clicks > L	short: 5 long: 0	short: 19 long: 0	short: 15 long: 0	short: 12 long: 1
Registration ">2 in 2sec"?	N	N	N	N
DIA Continuous (sec)	cont: 0.00	cont: 0.00	cont: 0.00	cont: 0.00
Only if "cont" > 0:				
Conform with exceptions 4.2.3?				
Total amount of clicks > L (short + long)	n = 5	n = 19	n = 15	n = 13
Switching operations: s= 0				
Observation time T = 120 min 00 sec				
Click Rate (N = n/T)	N = 0.04	N = 0.16	N = 0.13	N = 0.11
New limit: Lq = L + 20 log 30/N (maximum L + 44)	--	--	--	108.71 104.00
Amount of clicks > Lq	--	--	--	0
Observation time T = 120 min 00 sec				
% > Lq (max 25%)	--	--	--	3
Apparatus Passes (subject to exceptions)				
Click rate not > 5				
Run time limit reached				



Model : MDDO-10DEN7-QA3
 Test mode : TM1
 Test voltage : 230VAC, 50Hz
 Test specification : AC mains
 Test date : 2024-07-19

Frequency	150kHz	500kHz	1.4MHz	30MHz
Limit value (L)(dB/uV)	66	56	56	60
Amount of clicks > L	short: 2	short: 9	short: 5	short: 2
	long: 0	long: 0	long: 0	long: 0
Registration ">2 in 2sec"?	N	N	N	N
DIA Continuous (sec)	cont: 0.00	cont: 0.00	cont: 0.00	cont: 0.00
Only if "cont" > 0:				
Conform with exceptions 4.2.3?				
Total amount of clicks > L	n = 2	n = 9	n = 5	n = 2
(short + long)				
Switching operations: s= 0				
Observation time T = 120 min 00 sec				
Click Rate (N = n/T)	N = 0.02	N = 0.08	N = 0.04	N = 0.02
New limit: Lq = L + 20 log 30/N	--	--	--	--
(maximum L + 44)	--	--	--	--
Amount of clicks > Lq	--	--	--	--
Observation time T = -- min -- sec				
% > Lq (max 25%)	--	--	--	--
Apparatus Passes (subject to exceptions)				
Click rate not > 5 and no long click				
Run time limit reached				

2.3 Magnetic field induced current

2.3.1 Test Method

The magnetic component shall be measured by means of a loop antenna. The equipment shall be placed in the center of the antenna.

The induced current in the loop antenna is measured by means of a current probe and the CISPR measuring receiver. By means of a coaxial switch, the three field directions can be measured in sequence.

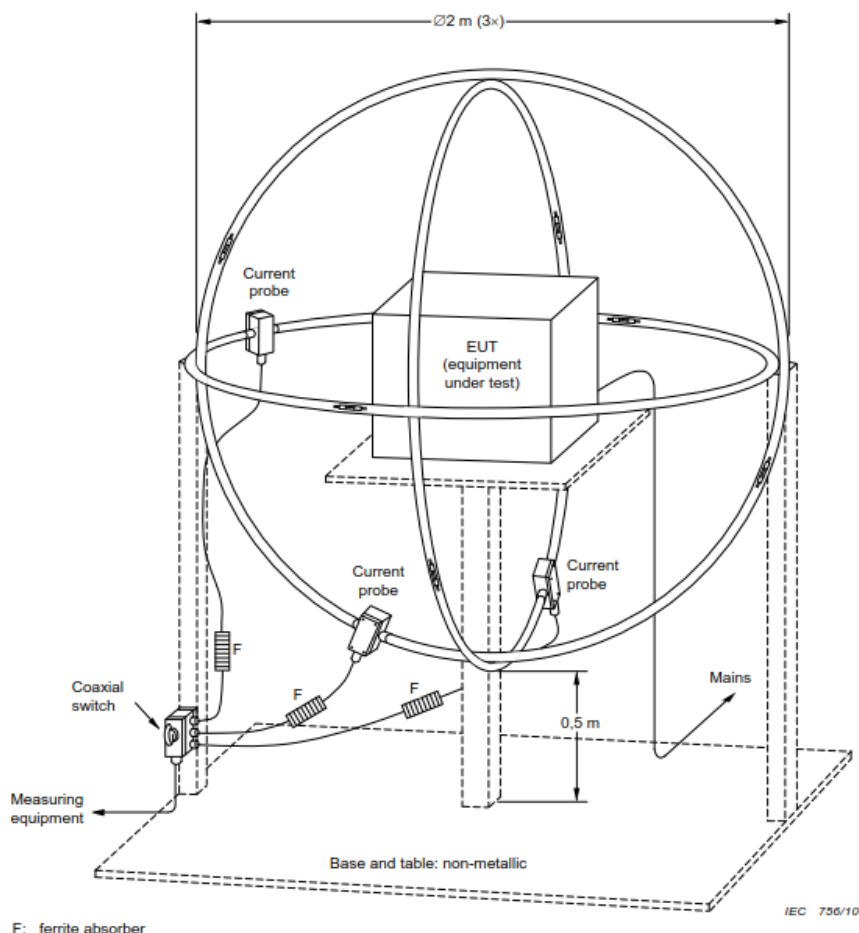

F: ferrite absorber

IEC 756/10

2.3.2 Specification Limits

Magnetic field induced current limits		
Frequency range	Limits dB(μ A)	
	Horizontal component Quasi-peak	Vertical component Quasi-peak
9kHz to 70kHz	88	106
70kHz to 150kHz	88 to 58	106 to 76
150kHz to 30MHz	58 to 22	76 to 40

Remark:

Level=Reading Level + Correction Factor

Correction Factor=Loop Antenna Factor + Cable Loss

(The Reading Level is recorded by software which is not shown in the sheet)

2.3.3 Test Setup

N/A

2.3.4 Test Location

This test was carried out in conducted emission shielded room.

2.3.5 Test Results

N/A

2.4 Disturbance power

2.4.1 Test Method

The associated equipment under test was placed on a 0.8 m non-conductive table for table-top equipment and on a 0.12 m insulated support for floor standing equipment and at least 0.8m from other metallic objects and from any person. The lead to be measured shall be stretched in a straight horizontal line for a length sufficient to accommodate the absorbing clamp. At each test frequency, the absorbing clamp shall be moved along the lead until the maximum value is found.

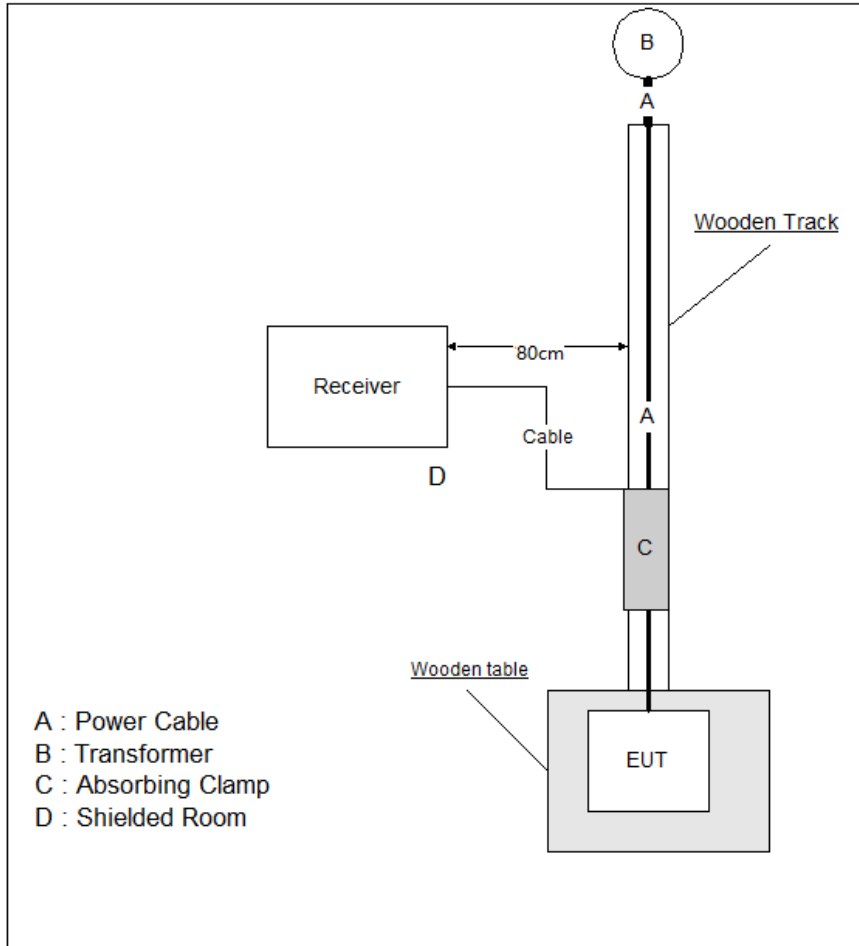



2.4.2 Specification Limits

Disturbance power limits for frequency range 30MHz to 300MHz		
Frequency range	Household and similar appliances dB(pW)	
MHz	Quasi-peak	Average
30 to 300	45 to 55	35 to 45

Margin when performing disturbance power measurement in the frequency range 30MHz to 300MHz		
Frequency range	Household and similar appliances dB(pW)	
MHz	Quasi-peak	Average
	Increasing linearly with the frequency from	
200 to 300	0 to 10 dB	-

Remark for test data:

*Level=Reading Level + Correction Factor

**Correction Factor=Cable Loss + Clamp Factor

(The Reading Level is recorded by software which is not shown in the sheet)

2.4.3 Test Setup

N/A

2.4.4 Test Location

This test was carried out in shielded room.

2.4.5 Test Results

N/A

2.5 Radiated Disturbance (30MHz to 6000MHz)

2.5.1 Test Method

The EUT was set up in a semi-anechoic chamber on a remotely controlled turntable and placed on a non-conductive. Guidance on how to arrange the EUT during the measurements can be found in 5.3.4.3.

Table-top EUT shall be placed at $(0,8 \pm 0,05)$ m above the reference plane of the test site selected for measurement.

Floor standing EUT shall be placed at $(0,12 \pm 0,04)$ m above the reference plane of the test site selected for measurement.

Where the EUT comprises multiple parts, these shall be arranged to minimise, as far as it is reasonably practical, the test volume. A minimum distance of 0,1 m shall be maintained between these parts.

A prescan of the EUT emissions profile was made while varying the antenna-to-EUT azimuth and antenna-to-EUT polarization using a peak detector; measurements were taken at a 3m distance. Using the prescan list of the highest emissions detected, their bearing and associated antenna polarization, the EUT was then formally measured using a Quasi-Peak detector. The readings were maximized by adjusting the antenna height, polarization and turntable azimuth, in accordance with the specification.

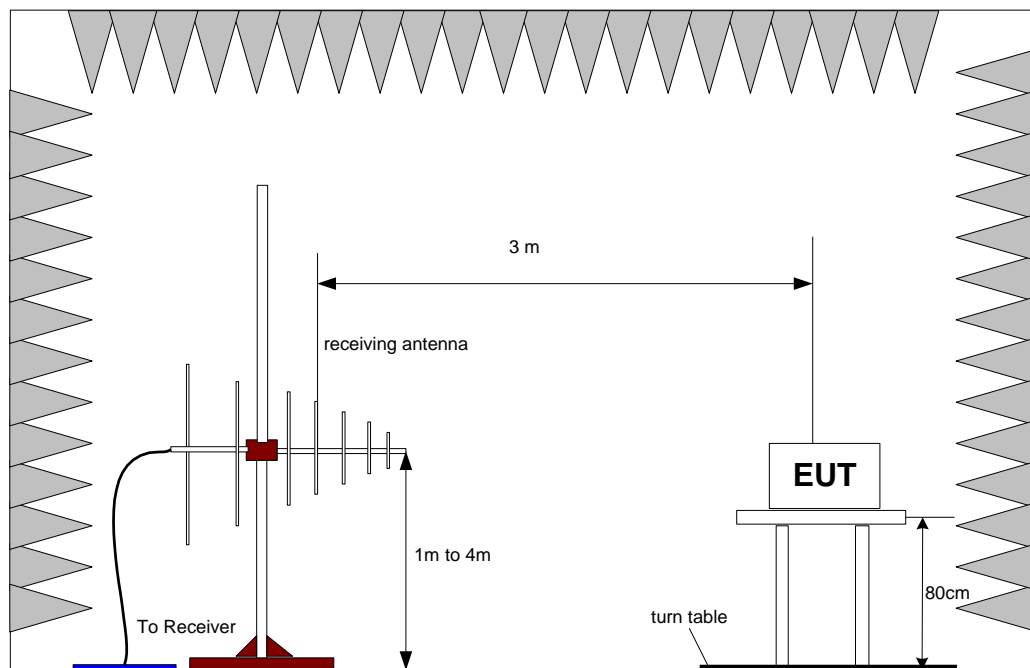

2.5.2 Specification Limits

Test Limits			
Frequency (MHz)	Distance (m)	QP (dBuV/m)	
30 - 230	3	40	
230 - 1000	3	47	
Frequency (GHz)	Distance (m)	Average (dBuV/m)	Peak (dBuV/m)
1-3	3	50	70
3-6	3	54	74

Remark :

Level=Reading Level + Correction Factor

Correction Factor=Antenna Factor + Cable Loss

(The Reading Level is recorded by software which is not shown in the sheet)

2.5.3 Test Setup

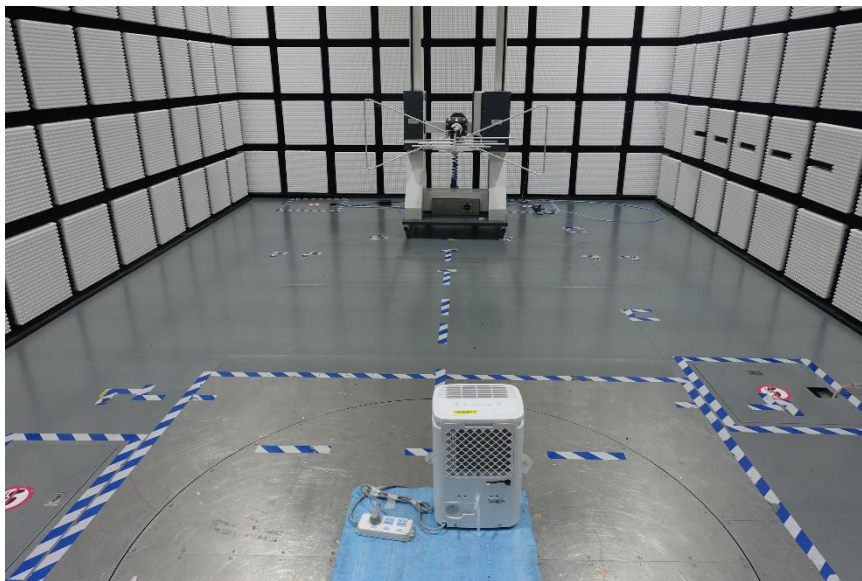

Below 1G

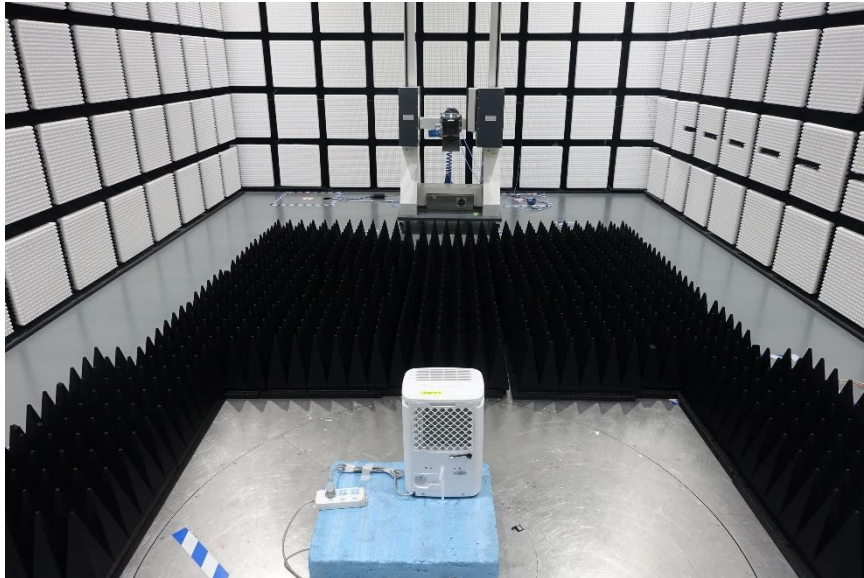

Above 1G

2.5.4 Test Location

This test was carried out in 3m SAC Test Location.

2.5.5 Test Results

Model : MDDO1-12DEN7-QA3
 Test mode : TM1
 Test voltage : 230VAC, 50Hz
 Test specification : Horizontal
 Test date : 2024-07-03

Radiated Emission 30MHz-1000MHz

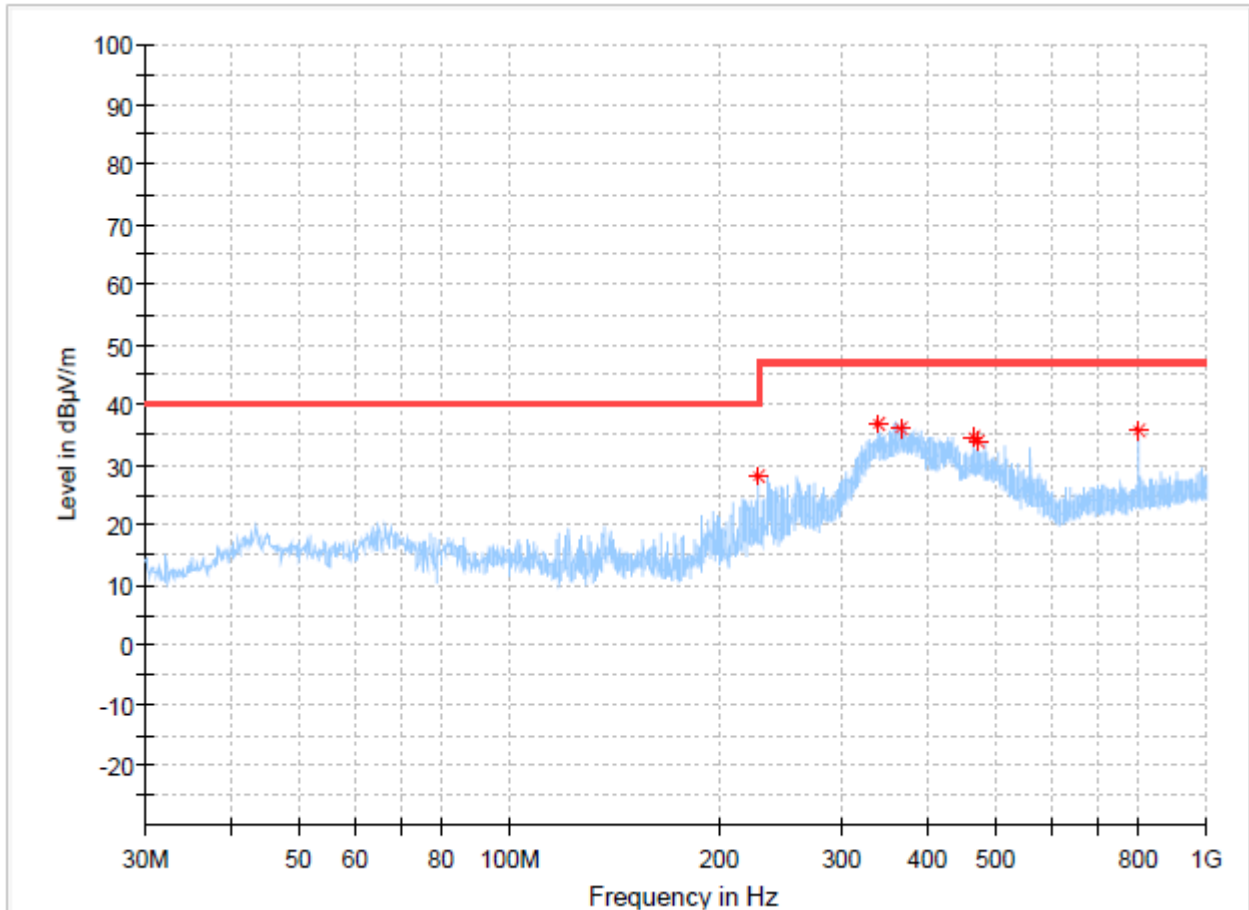

Critical Freqs

Frequency (MHz)	MaxPeak (dBµV/m)	Limit (dBµV/m)	Margin (dB)	Pol	Corr. (dB/m)
227.395000	28.27	40.00	11.73	H	-16.1
338.217500	36.68	47.00	10.32	H	-12.7
364.528750	35.92	47.00	11.08	H	-12.7
462.377500	34.53	47.00	12.47	H	-10.4
470.622500	34.06	47.00	12.94	H	-10.3
800.058750	35.58	47.00	11.42	H	-4.4



Model : MDDO1-12DEN7-QA3
 Test mode : TM1
 Test voltage : 230VAC, 50Hz
 Test specification : Vertical
 Test date : 2024-07-03

Radiated Emission 30MHz-1000MHz

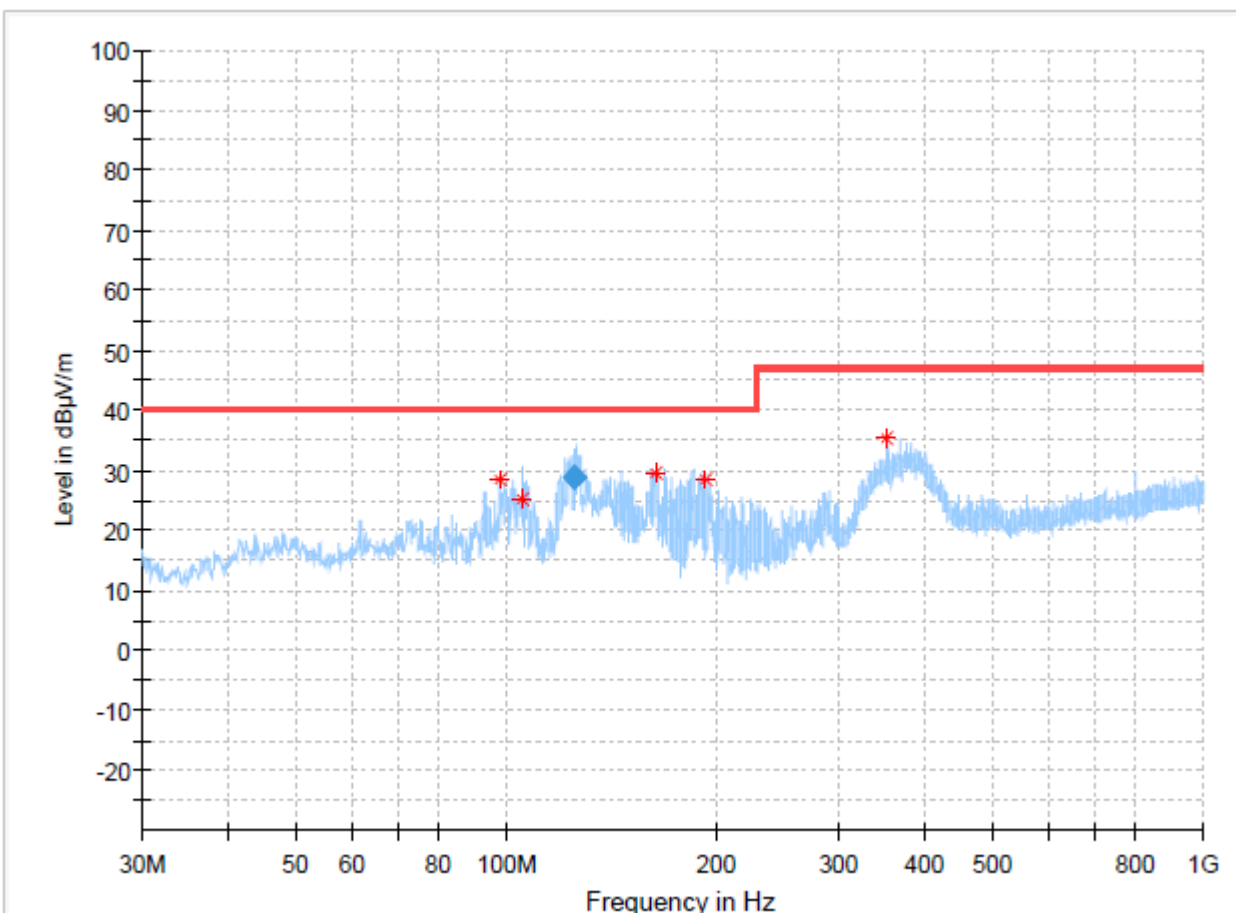

Critical Freqs

Frequency (MHz)	MaxPeak (dBµV/m)	Limit (dBµV/m)	Margin (dB)	Pol	Corr. (dB/m)
97.900000	28.45	40.00	11.55	V	-16.2
105.417500	25.23	40.00	14.77	V	-15.7
125.423750	28.95	40.00	11.05	V	-18.4
164.345000	29.54	40.00	10.46	V	-19.1
192.717500	28.48	40.00	11.52	V	-16.7
352.282500	35.23	47.00	11.77	V	-12.2

Final Result

Frequency (MHz)	QuasiPeak (dBµV/m)	Limit (dBµV/m)	Margin (dB)	Pol	Corr. (dB/m)
125.423750	28.93	40.00	11.07	V	-18.4



Model : MDDO1-12DEN7-QA3
 Test mode : TM1
 Test voltage : 230VAC, 50Hz
 Test specification : Horizontal
 Test date : 2024-07-03

Radiated Emission 1000MHz-6000MHz

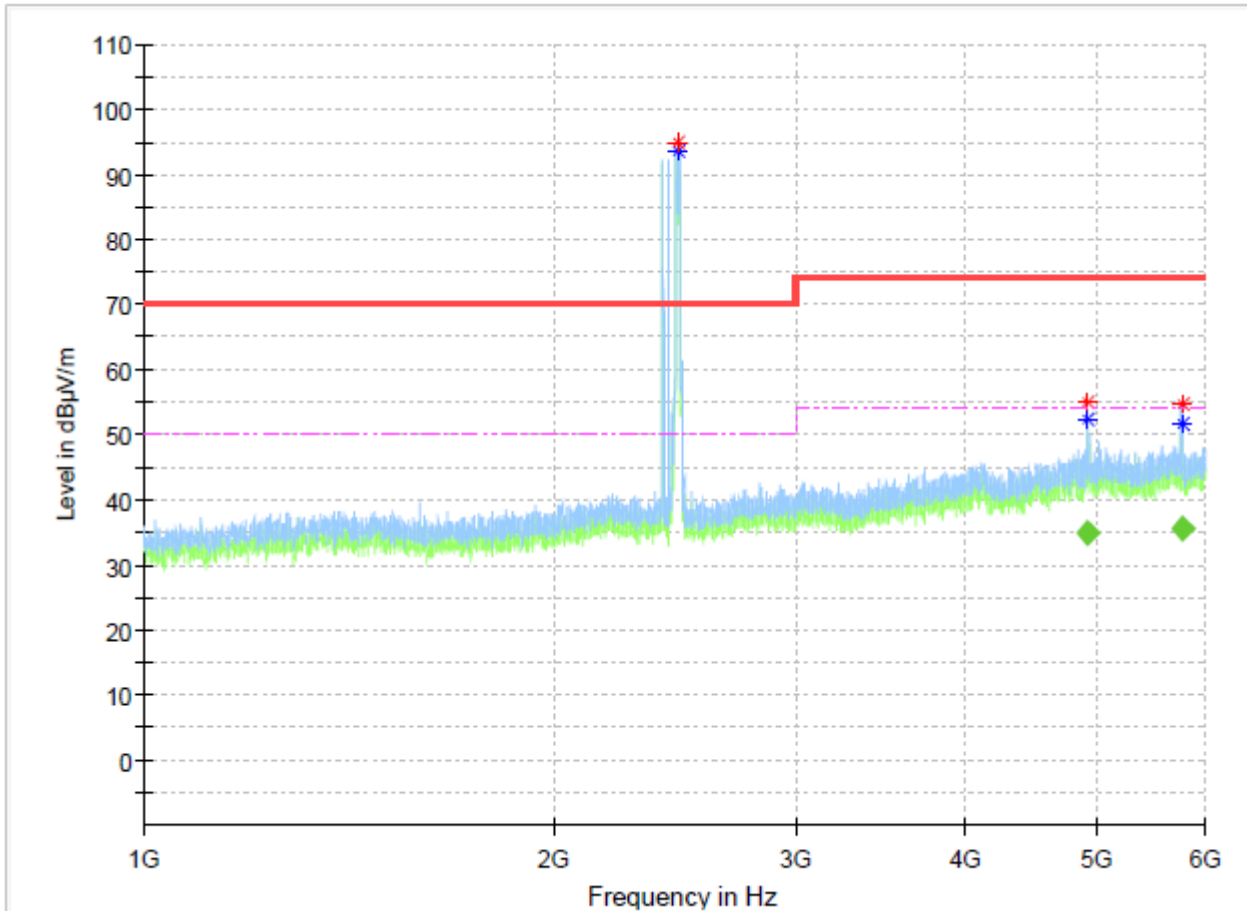

Remark: 2.4G band is the operating frequency for EUT

Critical Freqs

Frequency (MHz)	MaxPeak (dBµV/m)	Average (dBµV/m)	Limit (dBµV/m)	Margin (dB)	Pol	Corr. (dB/m)
2464.000000	94.93	---	70.00	-24.93	H	-13.0
2464.000000	---	93.46	50.00	-43.46	H	-13.0
4916.500000	---	52.25	54.00	1.75	H	-6.6
4921.000000	55.00	---	74.00	19.00	H	-6.6
5764.500000	54.75	---	74.00	19.25	H	-6.0
5764.500000	---	51.73	54.00	2.27	H	-6.0

Final Result

Frequency (MHz)	MaxPeak (dBµV/m)	Average (dBµV/m)	Limit (dBµV/m)	Margin (dB)	Pol	Corr. (dB/m)
4916.500000	---	34.87	54.00	19.13	H	-6.6
5764.500000	---	35.54	54.00	18.46	H	-6.0

Model : MDDO1-12DEN7-QA3
 Test mode : TM1
 Test voltage : 230VAC, 50Hz
 Test specification : Vertical
 Test date : 2024-07-03

Radiated Emission 1000MHz-6000MHz

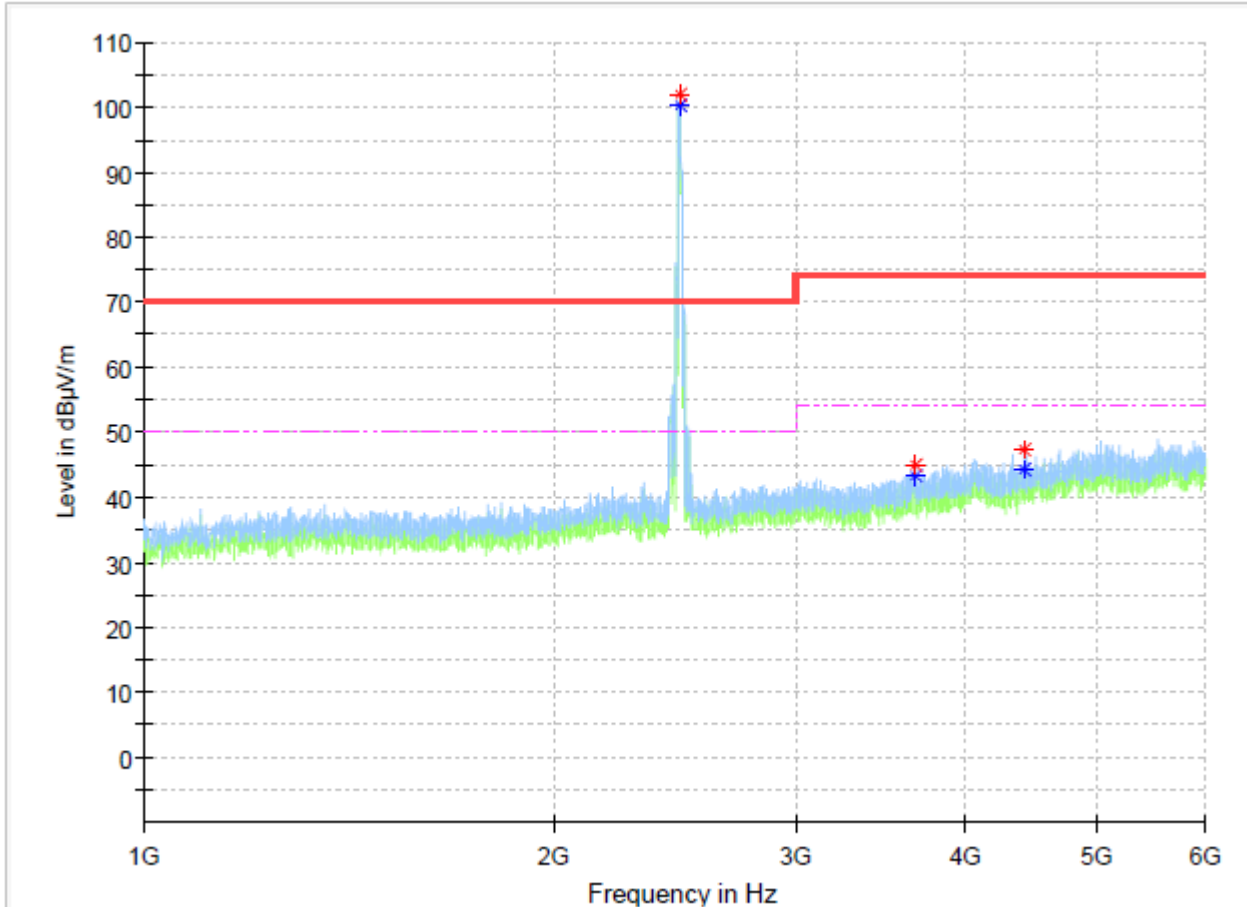

Remark: 2.4G band is the operating frequency for EUT

Critical Freqs

Frequency (MHz)	MaxPeak (dBµV/m)	Average (dBµV/m)	Limit (dBµV/m)	Margin (dB)	Pol	Corr. (dB/m)
2468.500000	---	100.39	50.00	-50.39	V	-13.0
2469.500000	101.83	---	70.00	-31.83	V	-13.0
3677.500000	44.99	---	74.00	29.01	V	-9.4
3677.500000	---	43.35	54.00	10.65	V	-9.4
4428.000000	---	44.36	54.00	9.64	V	-8.3
4428.000000	47.22	---	74.00	26.78	V	-8.3



Model : MDDO-12DEN7-QA3
 Test mode : TM1
 Test voltage : 230VAC, 50Hz
 Test specification : Horizontal
 Test date : 2024-08-08

Radiated Emission 30MHz-1000MHz

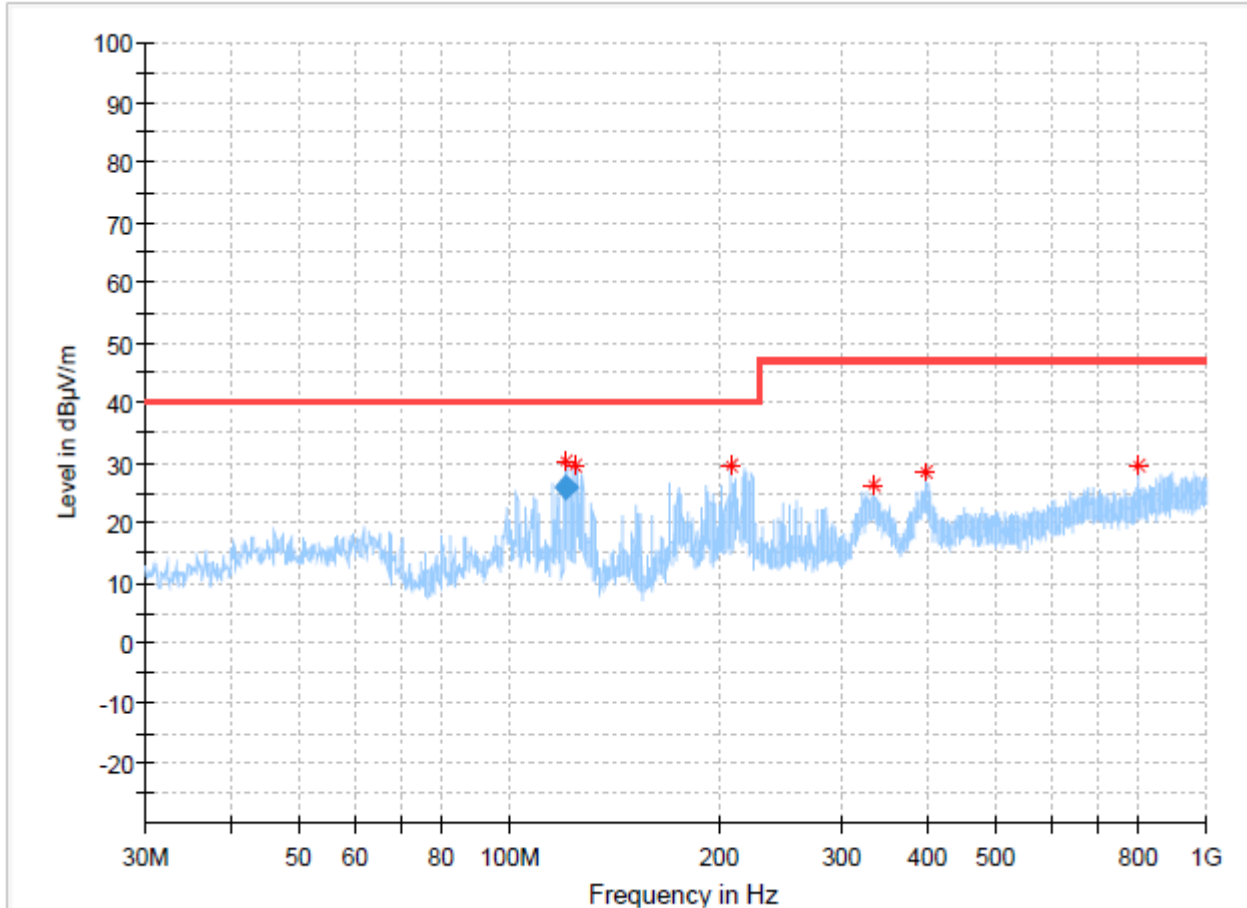

Critical Freqs

Frequency (MHz)	MaxPeak (dBµV/m)	Limit (dBµV/m)	Margin (dB)	Pol	Corr. (dB/m)
120.937500	30.17	40.00	9.83	H	-17.9
124.575000	29.47	40.00	10.53	H	-18.5
208.480000	29.69	40.00	10.31	H	-17.1
332.276250	26.15	47.00	20.85	H	-13.3
395.811250	28.36	47.00	18.64	H	-12.1
800.058750	29.43	47.00	17.57	H	-5.2

Final Result

Frequency (MHz)	QuasiPeak (dBµV/m)	Limit (dBµV/m)	Margin (dB)	Pol	Corr. (dB/m)
120.937500	25.99	40.00	14.01	V	-17.9

Model : MDDO-12DEN7-QA3
 Test mode : TM1
 Test voltage : 230VAC, 50Hz
 Test specification : Vertical
 Test date : 2024-08-08

Radiated Emission 30MHz-1000MHz

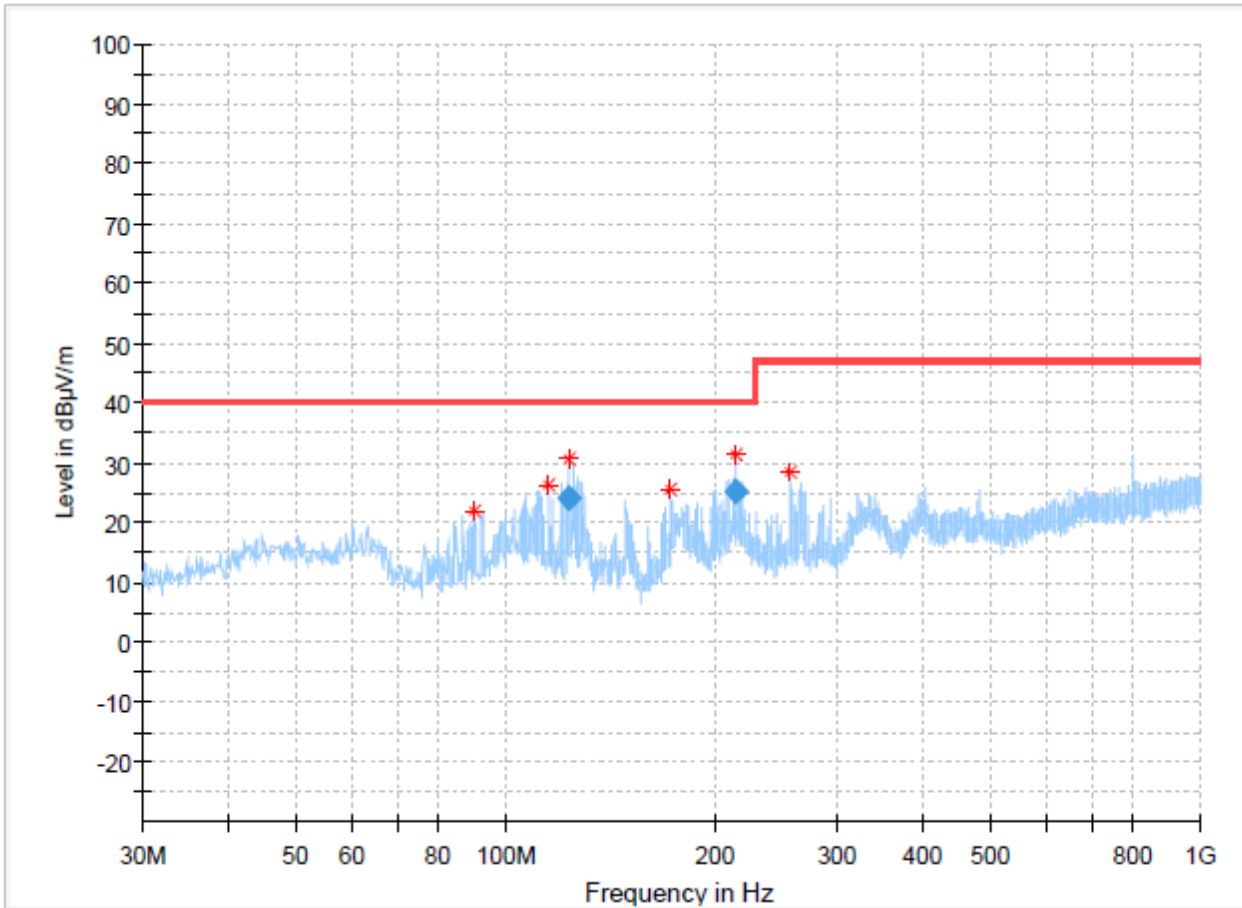

Critical Freqs

Frequency (MHz)	MaxPeak (dBµV/m)	Limit (dBµV/m)	Margin (dB)	Pol	Corr. (dB/m)
90.140000	21.84	40.00	18.16	V	-18.0
115.360000	26.13	40.00	13.87	V	-17.1
123.120000	30.75	40.00	9.25	V	-18.3
172.590000	25.58	40.00	14.42	V	-19.2
214.663750	31.27	40.00	8.73	V	-16.9
257.222500	28.44	47.00	18.56	V	-15.4

Final Result

Frequency (MHz)	QuasiPeak (dBµV/m)	Limit (dBµV/m)	Margin (dB)	Pol	Corr. (dB/m)
123.120000	24.07	40.00	15.93	V	-18.3
214.663750	25.26	40.00	14.74	V	-16.9



Model : MDDO-12DEN7-QA3
 Test mode : TM1
 Test voltage : 230VAC, 50Hz
 Test specification : Horizontal
 Test date : 2024-08-08

Radiated Emission 1000MHz-6000MHz

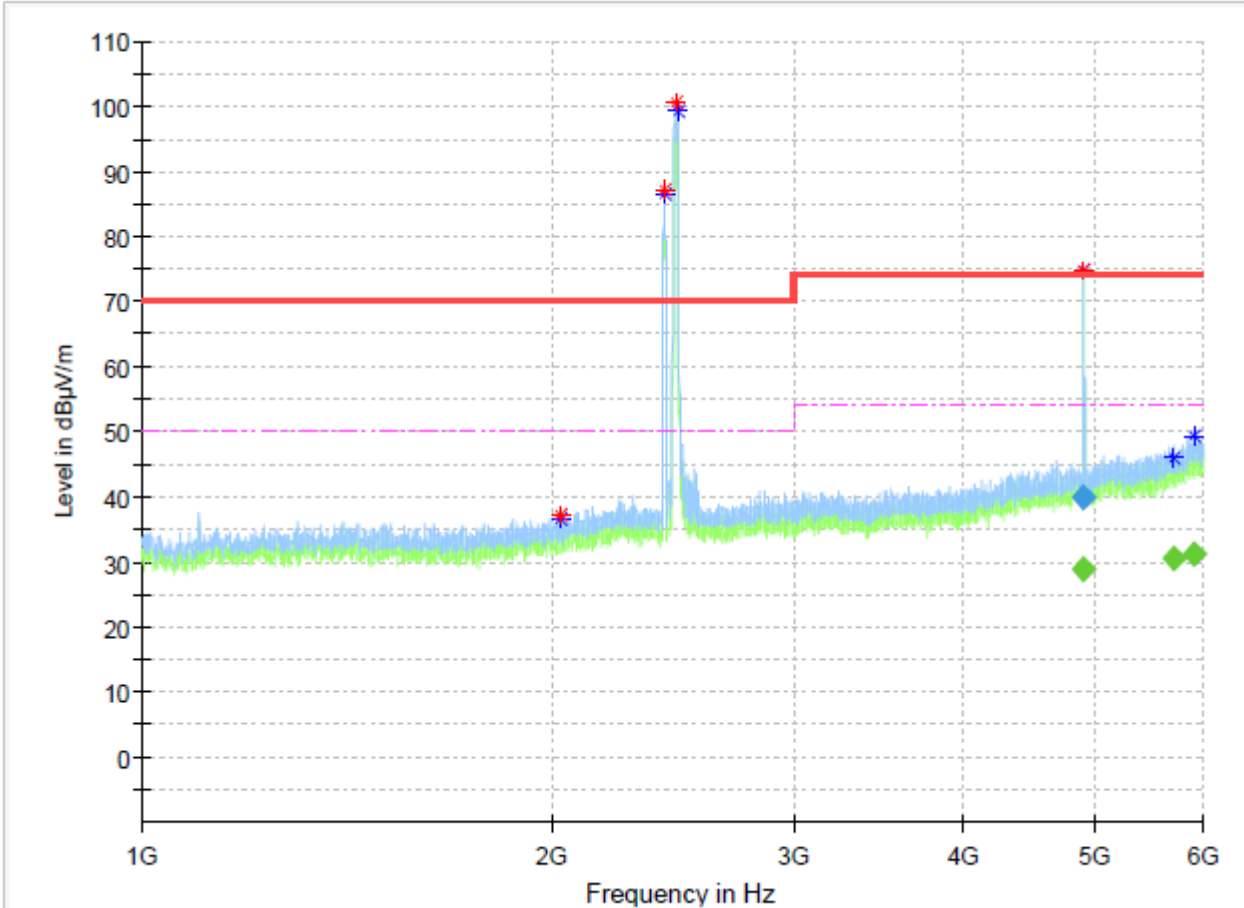

Remark: 2.4G band is the operating frequency for EUT

Critical Freqs

Frequency (MHz)	MaxPeak (dBµV/m)	Average (dBµV/m)	Limit (dBµV/m)	Margin (dB)	Pol	Corr. (dB/m)
2027.000000	---	36.50	50.00	13.50	H	-3.7
2027.000000	37.28	---	70.00	32.72	H	-3.7
2416.500000	---	86.60	50.00	-36.60	H	-2.3
2416.500000	87.18	---	70.00	-17.18	H	-2.3
2467.000000	100.64	---	70.00	-30.64	H	-2.4
2469.500000	---	99.21	50.00	-49.21	H	-2.4
4904.500000	74.94	---	74.00	-0.94	H	2.7
4904.500000	---	74.68	54.00	-20.68	H	2.7
5708.000000	---	46.08	54.00	7.92	H	5.6
5916.000000	---	49.20	54.00	4.80	H	6.4

Final Result

Frequency (MHz)	MaxPeak (dBµV/m)	Average (dBµV/m)	Limit (dBµV/m)	Margin (dB)	Pol	Corr. (dB/m)
4904.500000	---	28.79	54.00	25.21	H	2.7
4904.500000	40.02	---	74.00	33.98	H	2.7
5708.000000	---	30.55	54.00	23.45	H	5.6
5916.000000	---	31.13	54.00	22.87	H	6.4



Model : MDDO-12DEN7-QA3
 Test mode : TM1
 Test voltage : 230VAC, 50Hz
 Test specification : Vertical
 Test date : 2024-08-08

Radiated Emission 1000MHz-6000MHz

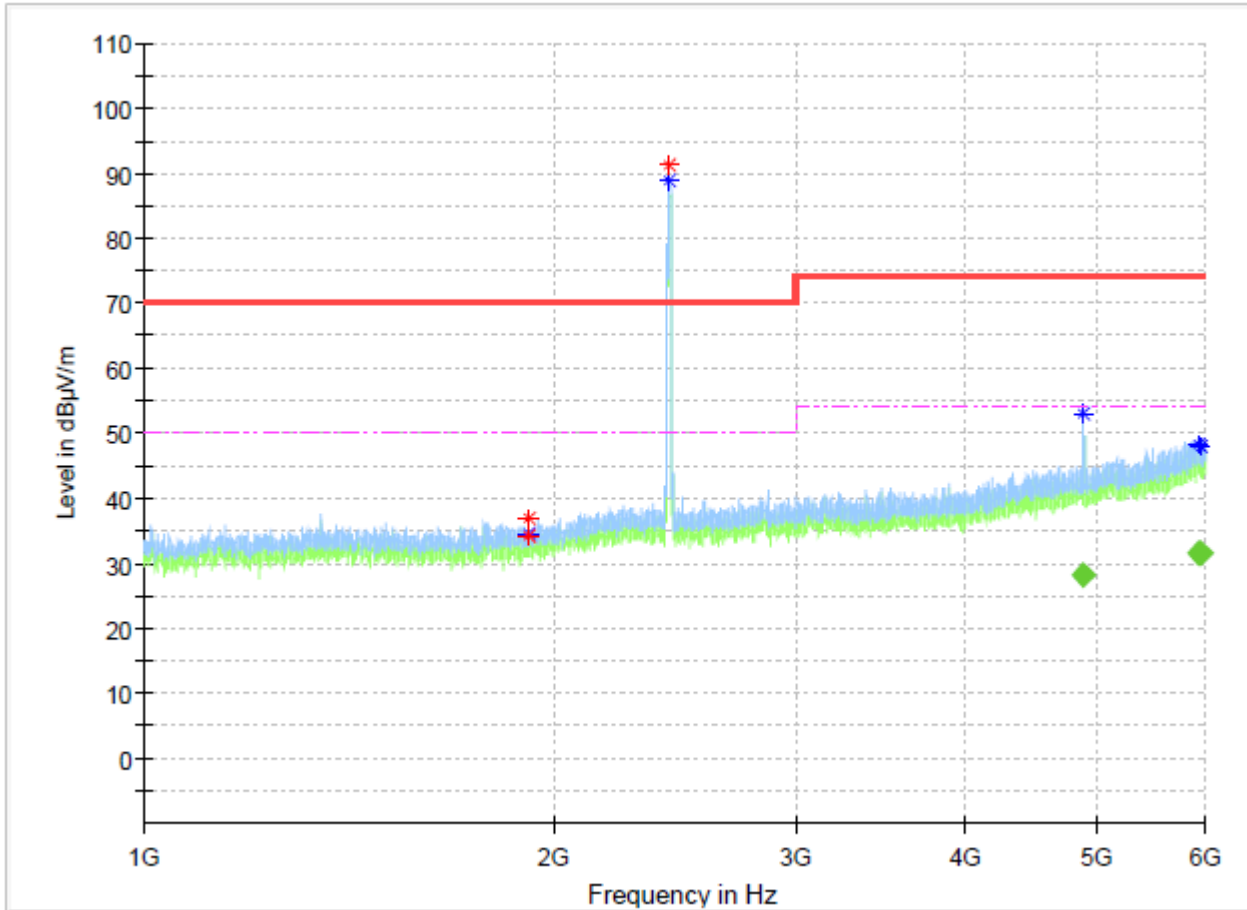

Remark: 2.4G band is the operating frequency for EUT

Critical Freqs

Frequency (MHz)	MaxPeak (dBµV/m)	Average (dBµV/m)	Limit (dBµV/m)	Margin (dB)	Pol	Corr. (dB/m)
1917.000000	---	34.62	50.00	15.38	V	-4.3
1917.000000	36.92	---	70.00	33.08	V	-4.3
1917.500000	34.33	---	70.00	35.67	V	-4.3
2427.000000	91.32	---	70.00	-21.32	V	-2.3
2428.500000	---	88.96	50.00	-38.96	V	-2.3
4884.500000	---	53.13	54.00	0.87	V	2.7
5924.000000	---	48.29	54.00	5.71	V	6.5
5960.500000	---	48.11	54.00	5.89	V	6.6

Final Result

Frequency (MHz)	MaxPeak (dBµV/m)	Average (dBµV/m)	Limit (dBµV/m)	Margin (dB)	Pol	Corr. (dB/m)
4884.500000	---	28.25	54.00	25.75	V	2.7
5924.000000	---	31.56	54.00	22.44	V	6.5
5960.500000	---	31.40	54.00	22.60	V	6.6



Model : MDDO1-10DEN7-QA3
 Test mode : TM1
 Test voltage : 230VAC, 50Hz
 Test specification : Horizontal
 Test date : 2024-09-05

Radiated Emission 30MHz-1000MHz Spectrum Overview H

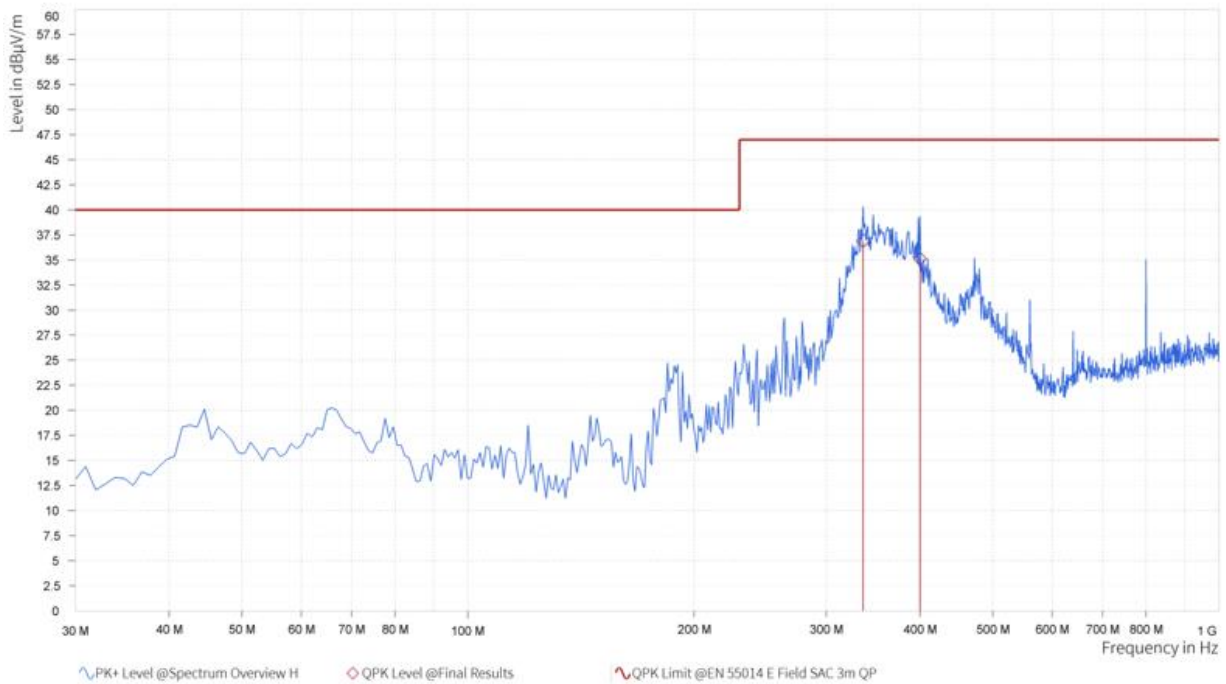

EMI Critical Points

Frequency [MHz]	PK+ Level [dBµV/m]	PK+: QPK Limit [dBµV/m]	PK+ Margin [dB]	Correction [dB]	Polarization	Azimuth [deg]	Antenna Height [m]
264.004	29.25	47.00	17.75	-15.45	H	345.5	1.00
335.856	40.35	47.00	6.65	-13.30	H	28.3	1.00
399.940	39.39	47.00	7.61	-12.10	H	298.8	1.00
472.763	35.22	47.00	11.78	-10.76	H	245.4	1.00
560.150	31.02	47.00	15.98	-9.18	H	205.9	1.00
799.980	35.06	47.00	11.94	-5.29	H	298.8	1.00

EMI Final Results

Frequency [MHz]	QPK Level [dBµV/m]	QPK Limit [dBµV/m]	QPK Margin [dB]	Correction [dB]	Polarization	Azimuth [deg]	Antenna Height [m]
335.856	36.92	47.00	10.08	-13.28	H	28.3	1.00
399.940	35.11	47.00	11.89	-12.08	H	298.8	1.00



Model : MDDO1-10DEN7-QA3
 Test mode : TM1
 Test voltage : 230VAC, 50Hz
 Test specification : Vertical
 Test date : 2024-09-05

Radiated Emission 30MHz-1000MHz

Spectrum Overview V

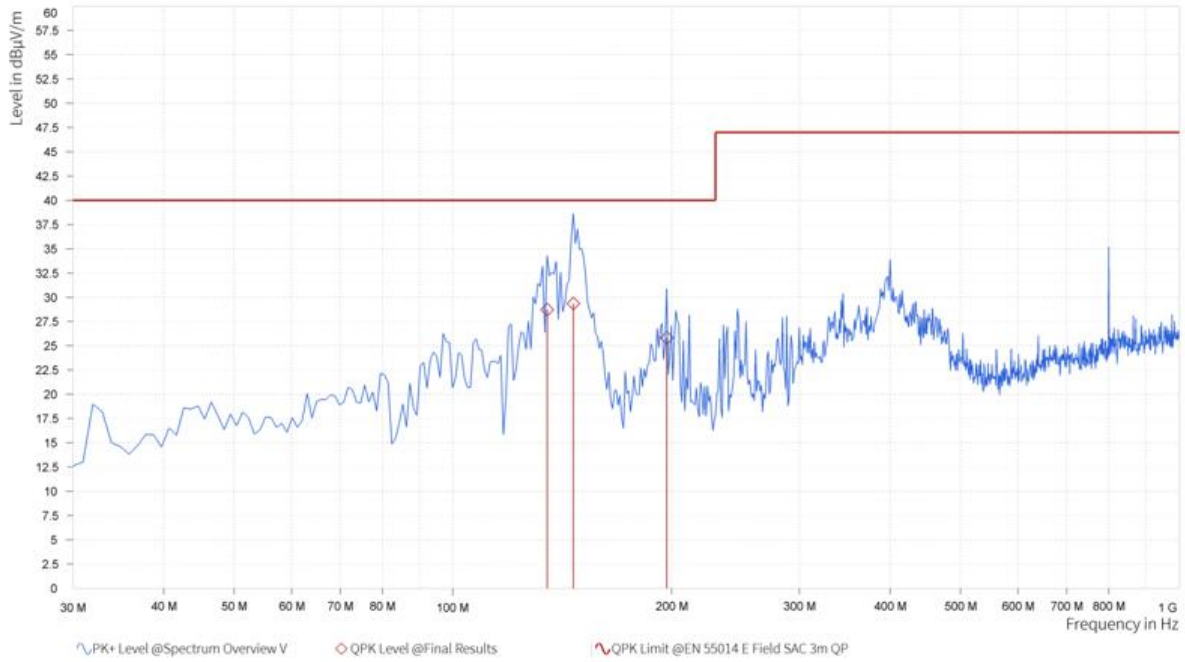

EMI Critical Points

Frequency [MHz]	PK+ Level [dBµV/m]	PK+: QPK Limit [dBµV/m]	PK+ Margin [dB]	Correction [dB]	Polarization	Azimuth [deg]	Antenna Height [m]
134.865	34.31	40.00	5.69	-19.65	V	38.4	1.00
146.517	38.65	40.00	1.35	-19.92	V	271	1.00
197.007	30.90	40.00	9.10	-16.35	V	240	1.00
246.527	28.79	47.00	18.21	-15.75	V	60.7	1.00
399.940	33.90	47.00	13.10	-12.10	V	300.3	1.00
799.980	35.18	47.00	11.82	-5.29	V	217.5	1.00

EMI Final Results

Frequency [MHz]	QPK Level [dBµV/m]	QPK Limit [dBµV/m]	QPK Margin [dB]	Correction [dB]	Polarization	Azimuth [deg]	Antenna Height [m]
134.865	28.71	40.00	11.29	-19.67	V	38.4	1.00
146.517	29.34	40.00	10.66	-19.92	V	271	1.00
197.007	25.82	40.00	14.18	-16.35	V	240	1.00

Model : MDDO1-10DEN7-QA3
 Test mode : TM1
 Test voltage : 230VAC, 50Hz
 Test specification : Horizontal
 Test date : 2024-09-05

Radiated Emission 1000MHz-6000MHz Spectrum Overview H

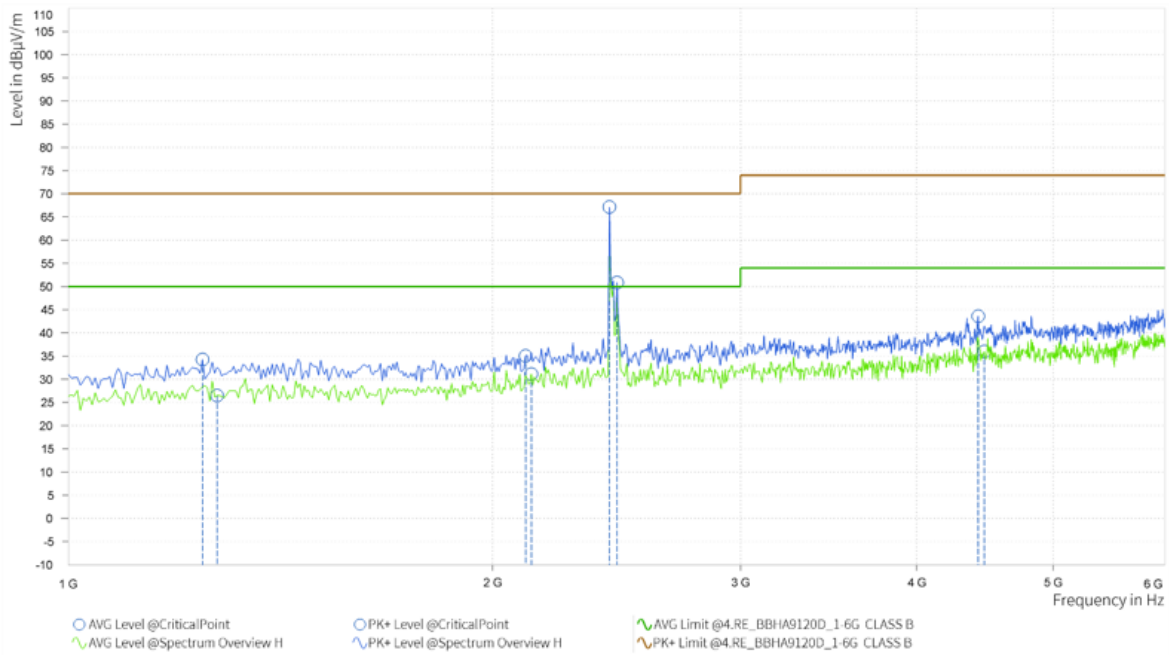

Remark: 2.4G band is the operating frequency for EUT

EMI Critical Points

Frequency [MHz]	PK+ Level [dBµV/m]	PK+ Limit [dBµV/m]	PK+ Margin [dB]	AVG Level [dBµV/m]	AVG Limit [dBµV/m]	AVG Margin [dB]	Correction [dB]	Polarization
1,245.245	34.24	70.00	35.76		50.00		-5.68	H
1,275.275		70.00		26.49	50.00	23.51	-5.47	H
2,111.111	35.06	70.00	34.94		50.00		-3.00	H
2,131.131		70.00		31.11	50.00	18.89	-2.81	H
2,421.421	67.15	70.00	2.85		50.00		-2.32	H
2,451.451	50.88	70.00	19.12		50.00		-2.37	H
4,423.423	43.61	74.00	30.39		54.00		1.34	H
4,468.468		74.00		36.00	54.00	18.00	1.42	H



Model : MDDO1-10DEN7-QA3
 Test mode : TM1
 Test voltage : 230VAC, 50Hz
 Test specification : Vertical
 Test date : 2024-09-05

Radiated Emission 1000MHz-6000MHz

Spectrum Overview V

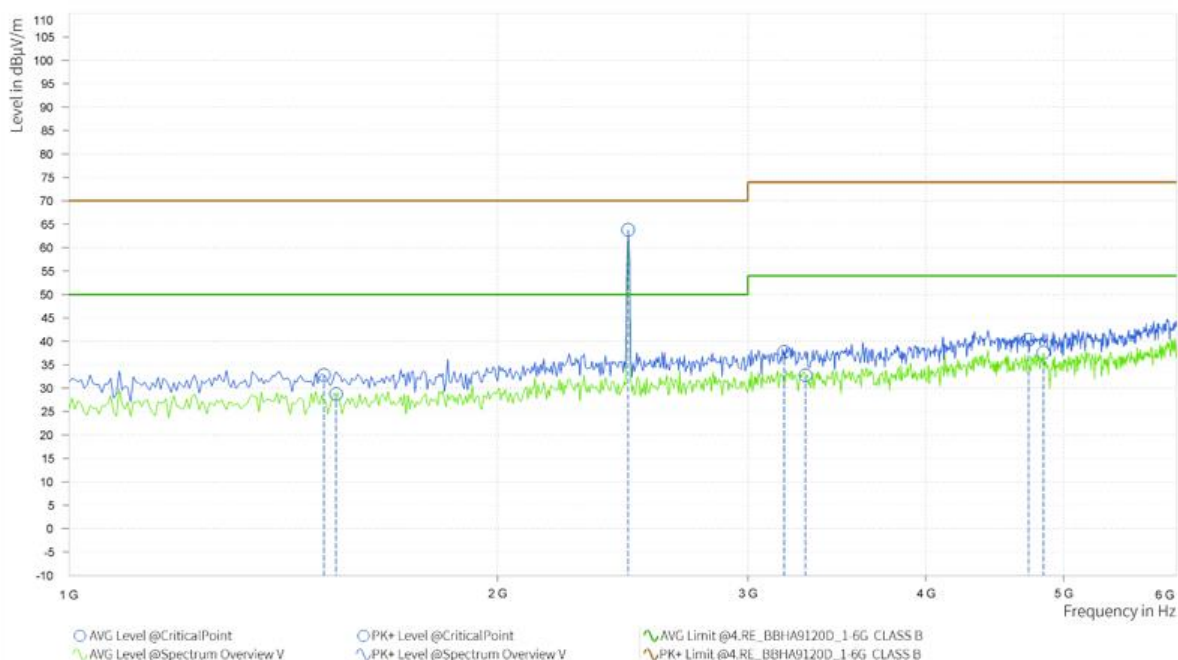

Remark: 2.4G band is the operating frequency for EUT

EMI Critical Points

Frequency [MHz]	PK+ Level [dBµV/m]	PK+ Limit [dBµV/m]	PK+ Margin [dB]	AVG Level [dBµV/m]	AVG Limit [dBµV/m]	AVG Margin [dB]	Correction [dB]	Polarization
1,510.511	32.83	70.00	37.17		50.00		-4.96	V
1,540.541		70.00		28.73	50.00	21.27	-5.05	V
2,471.471	63.83	70.00	6.17		50.00		-2.36	V
3,182.182	37.76	74.00	36.24		54.00		-0.87	V
3,292.292		74.00		32.73	54.00	21.27	-1.35	V
4,723.724	40.36	74.00	33.64		54.00		2.25	V
4,838.839		74.00		37.61	54.00	16.39	2.55	V



Model : MDDO-10DEN7-QA3
 Test mode : TM1
 Test voltage : 230VAC, 50Hz
 Test specification : Horizontal
 Test date : 2024-09-05

Radiated Emission 30MHz-1000MHz Spectrum Overview H

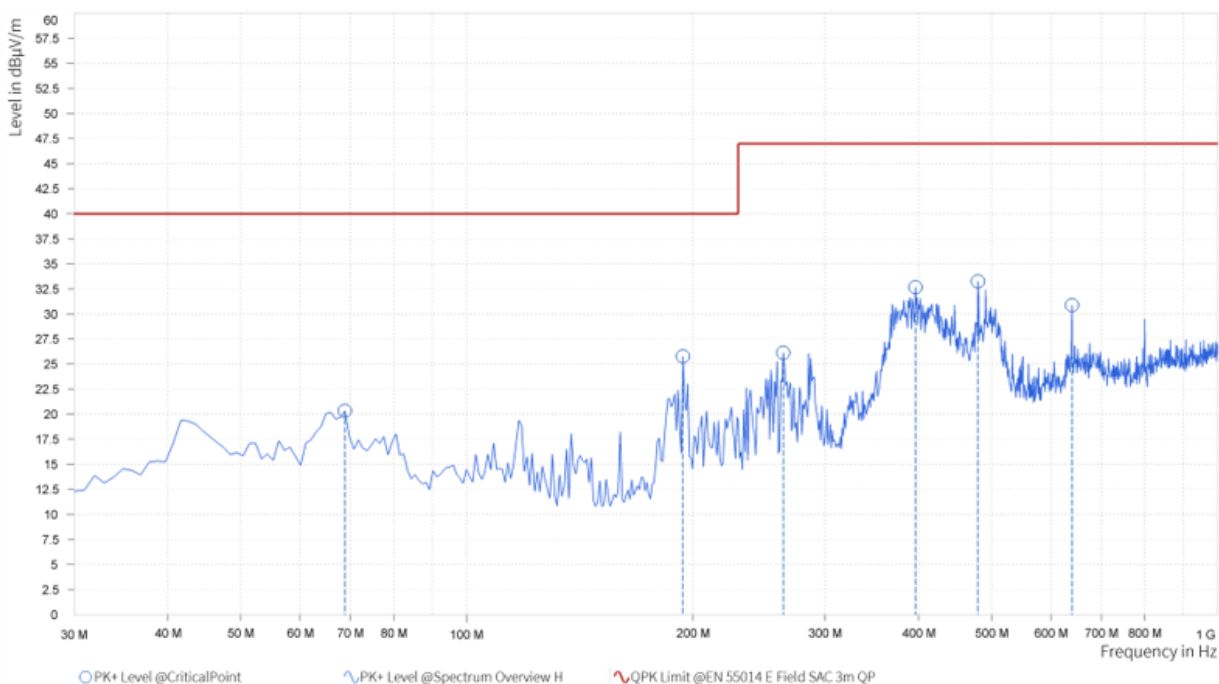

EMI Critical Points

Frequency [MHz]	PK+ Level [dBµV/m]	PK+: QPK Limit [dBµV/m]	PK+ Margin [dB]	Correction [dB]	Polarization	Azimuth [deg]	Antenna Height [m]
68.839	20.33	40.00	19.67	-18.22	H	247.3	1.00
194.094	25.76	40.00	14.24	-16.82	H	0.1	1.00
264.004	26.12	47.00	20.88	-15.45	H	316.4	1.00
396.056	32.67	47.00	14.33	-12.19	H	151	1.00
479.560	33.25	47.00	13.75	-10.48	H	73.2	1.00
639.770	30.88	47.00	16.12	-7.58	H	0.1	1.00



Model : MDDO-10DEN7-QA3
 Test mode : TM1
 Test voltage : 230VAC, 50Hz
 Test specification : Vertical
 Test date : 2024-09-05

Radiated Emission 30MHz-1000MHz

Spectrum Overview V

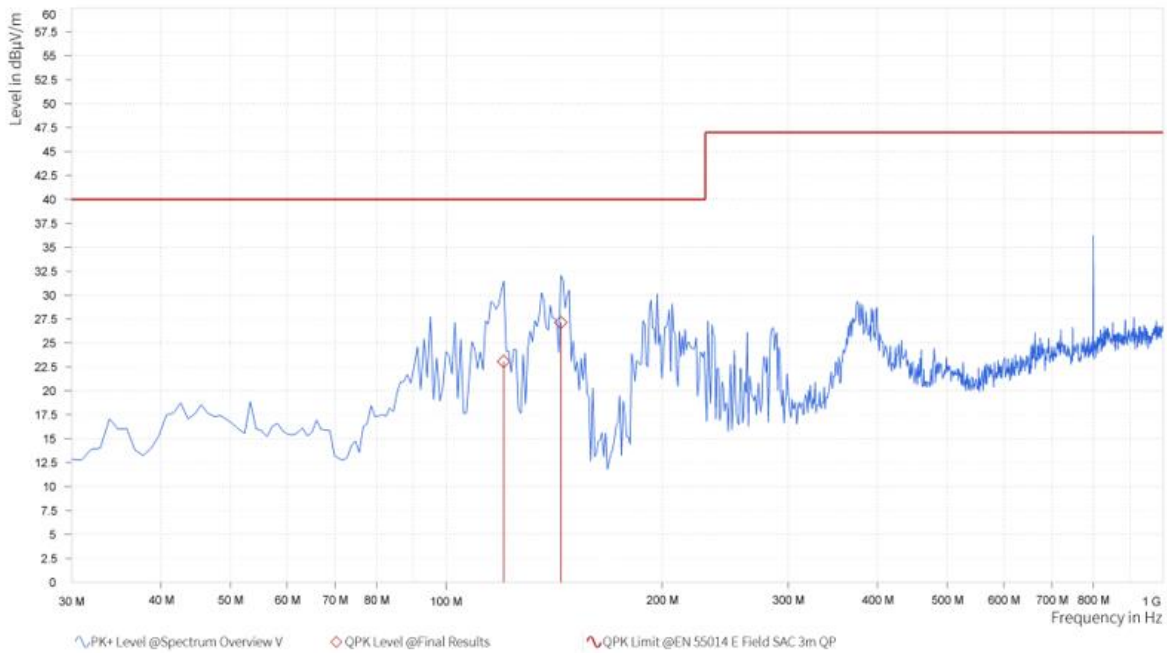

EMI Critical Points

Frequency [MHz]	PK+ Level [dBµV/m]	PK+: QPK Limit [dBµV/m]	PK+ Margin [dB]	Correction [dB]	Polarization	Azimuth [deg]	Antenna Height [m]
120.300	31.49	40.00	8.51	-17.82	V	101.1	1.00
144.575	32.06	40.00	7.94	-19.92	V	176.8	1.00
197.007	30.13	40.00	9.87	-16.35	V	37.6	1.00
285.365	26.59	47.00	20.41	-14.71	V	68.6	1.00
286.336	26.55	47.00	20.45	-14.70	V	68.6	1.00
374.695	29.38	47.00	17.62	-12.86	V	278.2	1.00

EMI Final Results

Frequency [MHz]	QPK Level [dBµV/m]	QPK Limit [dBµV/m]	QPK Margin [dB]	Correction [dB]	Polarization	Azimuth [deg]	Antenna Height [m]
120.300	23.07	40.00	16.93	-17.89	V	101.1	1.00
144.575	27.13	40.00	12.87	-19.92	V	176.8	1.00



Model : MDDO-10DEN7-QA3
 Test mode : TM1
 Test voltage : 230VAC, 50Hz
 Test specification : Horizontal
 Test date : 2024-09-05

Radiated Emission 1000MHz-6000MHz Spectrum Overview H

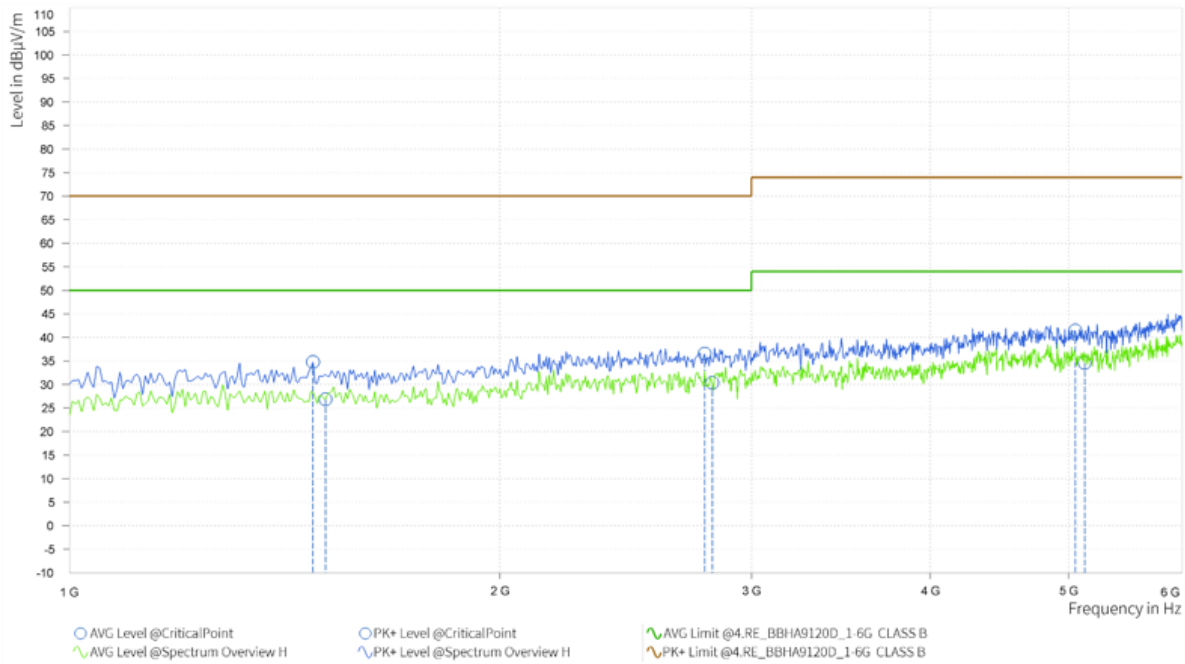

EMI Critical Points

Frequency [MHz]	PK+ Level [dBµV/m]	PK+ Limit [dBµV/m]	PK+ Margin [dB]	AVG Level [dBµV/m]	AVG Limit [dBµV/m]	AVG Margin [dB]	Correction [dB]	Polarization
1,480.480	34.77	70.00	35.23		50.00		-5.00	H
1,510.511		70.00		26.85	50.00	23.15	-4.96	H
2,781.782	36.54	70.00	33.46		50.00		-1.90	H
2,816.817		70.00		30.36	50.00	19.64	-1.77	H
5,054.054	41.47	74.00	32.53		54.00		3.76	H
5,129.129		74.00		34.55	54.00	19.45	4.02	H



Model : MDDO-10DEN7-QA3
 Test mode : TM1
 Test voltage : 230VAC, 50Hz
 Test specification : Vertical
 Test date : 2024-09-05

Radiated Emission 1000MHz-6000MHz

Spectrum Overview V

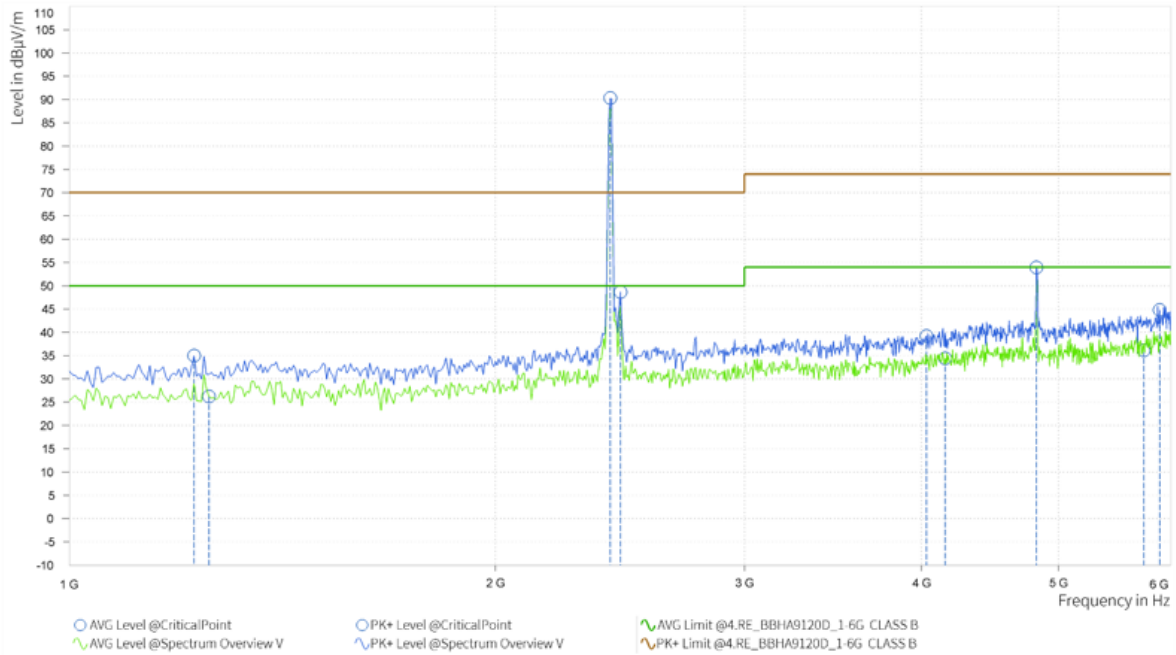

Remark: 2.4G band is the operating frequency for EUT

EMI Critical Points

Frequency [MHz]	PK+ Level [dBµV/m]	PK+ Limit [dBµV/m]	PK+ Margin [dB]	AVG Level [dBµV/m]	AVG Limit [dBµV/m]	AVG Margin [dB]	Correction [dB]	Polarization
1,225.225	35.01	70.00	34.99		50.00		-5.77	V
1,255.255		70.00		26.20	50.00	23.80	-5.62	V
2,411.411	90.30	70.00	-20.30		50.00		-2.31	V
2,451.451	48.68	70.00	21.32		50.00		-2.37	V
4,033.033	39.24	74.00	34.76		54.00		-0.61	V
4,158.158		74.00		34.42	54.00	19.58	-0.26	V
4,823.824	53.92	74.00	20.08		54.00		2.49	V
5,744.745		74.00		36.13	54.00	17.87	5.75	V
5,894.895	44.82	74.00	29.18		54.00		6.36	V

2.6 Harmonic current emission

2.6.1 Test Method

Harmonic current test should be conducted with the user's operation control or automatic programs set to the mode expected to produce the maximum total harmonic current under normal operating conditions.

Specific test conditions for the measurement of harmonic currents associated with some types of equipment are given in test equipment list.

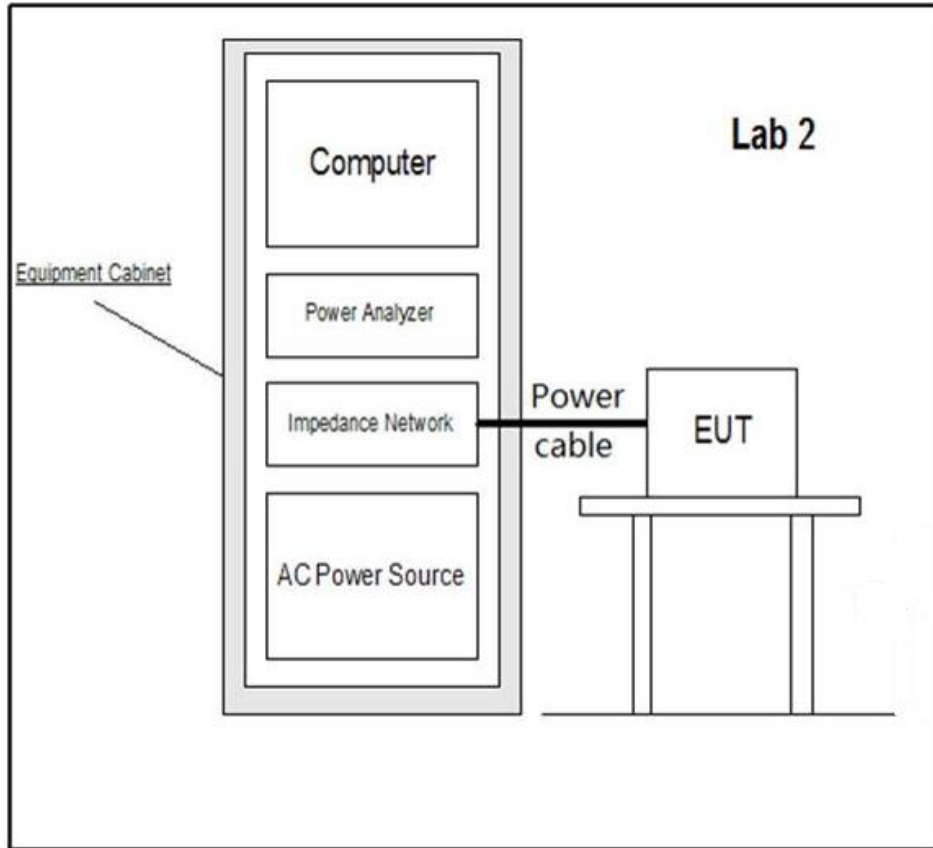

2.6.2 Specification Limits

Limits for class A Equipment	
Harmonic order n	Maximum permissible harmonic current A
Odd harmonics	
3	2.30
5	1.14
7	0.77
9	0.40
11	0.33
13	0.21
$15 \leq n \leq 39$	$0.15(15/n)$
Even harmonics	
2	1.08

Limits for class A Equipment	
4	0.43
6	0.30
$8 \leq n \leq 40$	$0.23(8/n)$

2.6.3 Test Setup

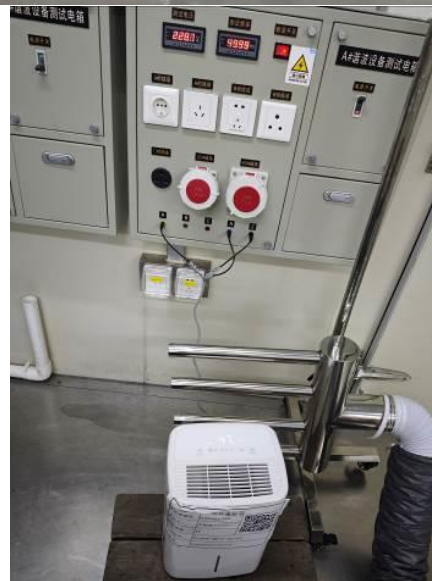

2.6.4 Test Location

This test was carried out in Harmonic Flicker Test area.

2.6.5 Test Results

Results for Configuration and Mode: TC1/TM1

Performance assessment of the EUT made during this test: Pass

Detailed results are shown below:

Model : MDDO1-12DEN7-QA3
 Test date : 2024-07-13

Harmonics – Class-A per IEC 61000-3-2:2018/AMD1:2020(Run time) incl. inter-harmonics

Test category: Class-A (European limits) **Test Margin: 100**
Start time: 17:31:37 **End time: 17:34:20**
Test duration (min): 2.5 **Data file name: CTSMXL_H-000433.cts_data**
Comment: Comment
Customer: Customer information

Test Result: Pass **Source qualification: Normal**

Current & voltage waveforms

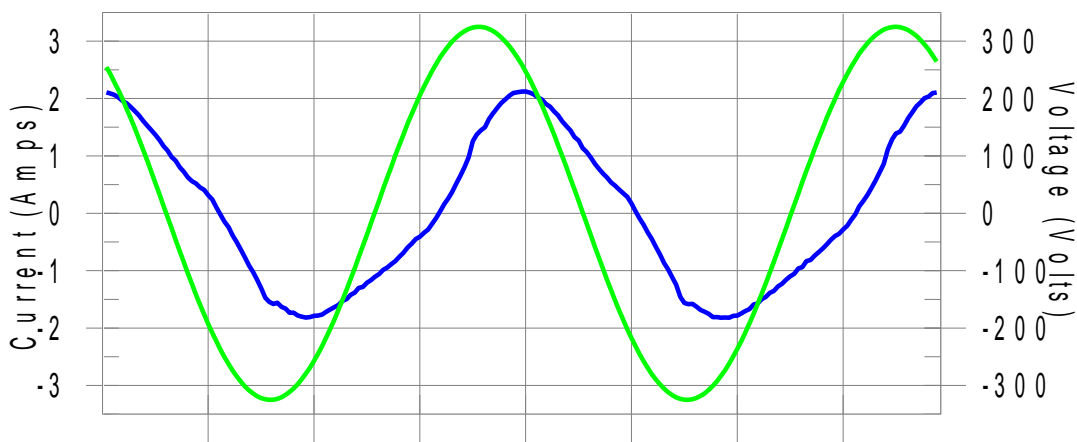

Harmonics and Class A limit line European Limits

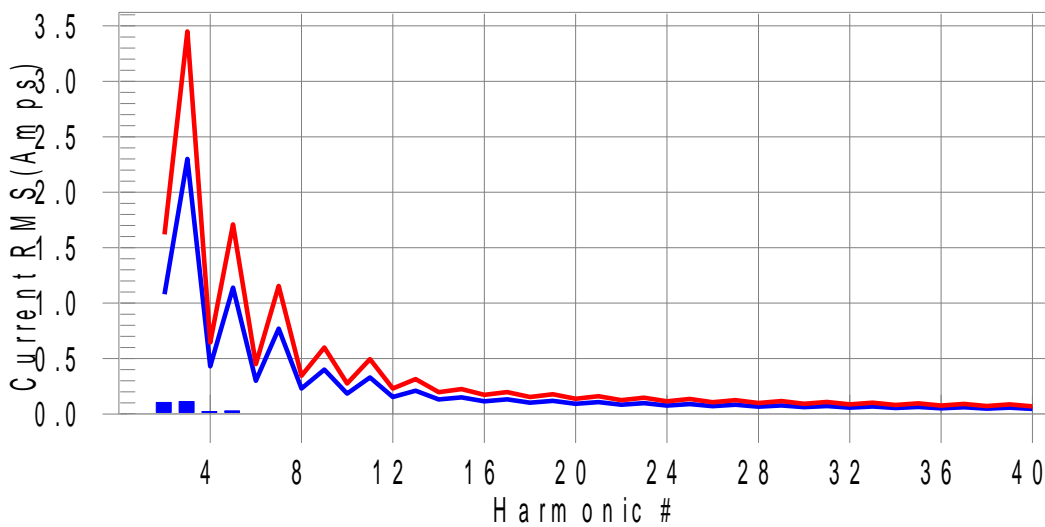

Test result: Pass **Worst harmonics H2-6.5% of 150% limit, H2-9.7% of 100% limit.**



Current Test Result Summary (Run time)

Test category: Class-A (European limits) Test Margin: 100
 Start time: 17:31:37 End time: 17:34:20
 Test duration (min): 2.5 Data file name: CTSMXL_H-000433.cts_data
 Comment: Comment
 Customer: Customer information

Test Result: Pass Source qualification: Normal
 THC(A): 0.160 I-THD(%): 12.3 POHC(A): 0.009 POHC Limit(A): 0.251

Highest parameter values during test:

V_RMS (Volts): 229.900	Frequency(Hz): 50.00
I_Peak (Amps): 2.246	I_RMS (Amps): 1.317
I_Fund (Amps): 1.302	Crest Factor: 1.709
Power (Watts): 216.0	Power Factor: 0.722

Harm#	Harms(avg)	100%Limit	%of Limit	Harms(max)	150%Limit	%of Limit	Status
2	0.104	1.080	9.7	0.106	1.620	6.5	Pass
3	0.112	2.300	4.9	0.114	3.450	3.3	Pass
4	0.023	0.430	5.3	0.024	0.645	3.7	Pass
5	0.029	1.140	2.5	0.029	1.710	1.7	Pass
6	0.011	0.300	3.8	0.012	0.450	2.8	Pass
7	0.011	0.770	1.4	0.012	1.155	1.0	Pass
8	0.005	0.230	N/A	0.005	0.345	N/A	Pass
9	0.009	0.400	2.4	0.010	0.600	1.7	Pass
10	0.003	0.184	N/A	0.005	0.276	N/A	Pass
11	0.012	0.330	3.5	0.012	0.495	2.4	Pass
12	0.003	0.153	N/A	0.003	0.230	N/A	Pass
13	0.009	0.210	4.1	0.009	0.315	2.8	Pass
14	0.002	0.131	N/A	0.003	0.197	N/A	Pass
15	0.007	0.150	N/A	0.007	0.225	N/A	Pass
16	0.002	0.115	N/A	0.002	0.173	N/A	Pass
17	0.006	0.132	N/A	0.007	0.198	N/A	Pass
18	0.002	0.102	N/A	0.002	0.153	N/A	Pass
19	0.006	0.118	N/A	0.006	0.178	N/A	Pass
20	0.001	0.092	N/A	0.002	0.138	N/A	Pass
21	0.005	0.107	N/A	0.006	0.161	N/A	Pass
22	0.001	0.084	N/A	0.001	0.125	N/A	Pass
23	0.004	0.098	N/A	0.005	0.147	N/A	Pass
24	0.001	0.077	N/A	0.001	0.115	N/A	Pass
25	0.004	0.090	N/A	0.004	0.135	N/A	Pass
26	0.001	0.071	N/A	0.001	0.107	N/A	Pass
27	0.003	0.083	N/A	0.003	0.125	N/A	Pass
28	0.001	0.066	N/A	0.001	0.099	N/A	Pass
29	0.002	0.078	N/A	0.003	0.116	N/A	Pass
30	0.001	0.061	N/A	0.001	0.092	N/A	Pass
31	0.002	0.073	N/A	0.002	0.109	N/A	Pass
32	0.001	0.058	N/A	0.001	0.086	N/A	Pass
33	0.001	0.068	N/A	0.002	0.102	N/A	Pass
34	0.001	0.054	N/A	0.001	0.081	N/A	Pass
35	0.001	0.064	N/A	0.001	0.096	N/A	Pass
36	0.001	0.051	N/A	0.001	0.077	N/A	Pass
37	0.001	0.061	N/A	0.001	0.091	N/A	Pass
38	0.001	0.048	N/A	0.001	0.073	N/A	Pass
39	0.001	0.058	N/A	0.001	0.087	N/A	Pass
40	0.001	0.046	N/A	0.001	0.069	N/A	Pass



Model : MDDO-10DEN7-QA3
 Test date : 2024-07-19

Harmonics – Class-A per IEC 61000-3-2:2018/AMD1:2020(Run time) incl. inter-harmonics

Test category: Class-A (European limits) Test Margin: 100
 Start time: 20:44:44 End time: 20:47:26
 Test duration (min): 2.5 Data file name: CTSMXL_H-000809.cts_data
 Comment: Comment
 Customer: Customer information

Test Result: Pass Source qualification: Normal

Current & voltage waveforms

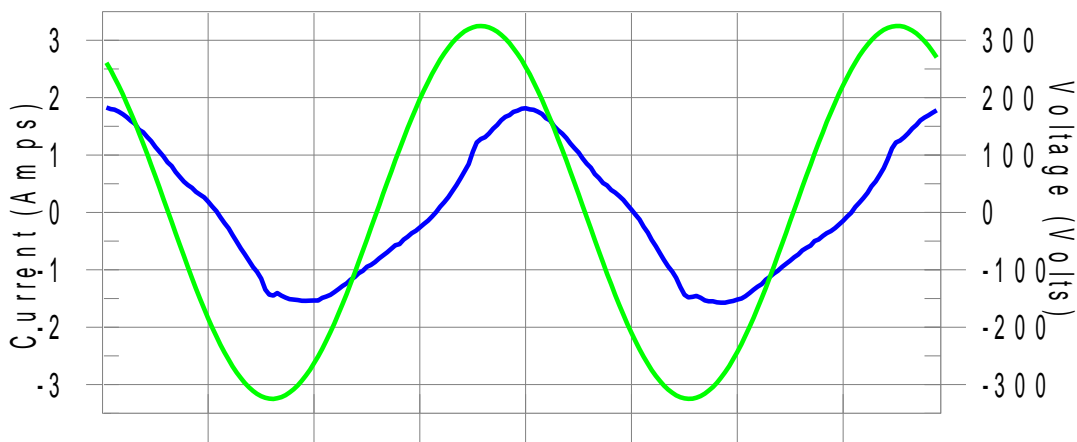

Harmonics and Class A limit line European Limits

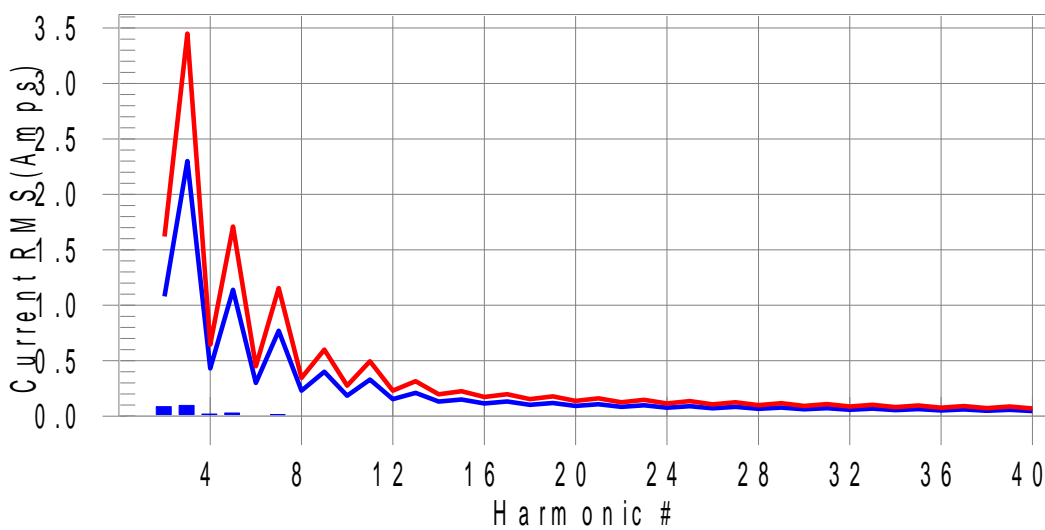

Test result: Pass Worst harmonics H2-5.5% of 150% limit, H2-7.9% of 100% limit.



Current Test Result Summary (Run time)

Test category: Class-A (European limits) Test Margin: 100
 Start time: 20:44:44 End time: 20:47:26
 Test duration (min): 2.5 Data file name: CTSMXL_H-000809.cts_data
 Comment: Comment
 Customer: Customer information

Test Result: Pass Source qualification: Normal
 THC(A): 0.137 I-THD(%): 12.3 POHC(A): 0.009 POHC Limit(A): 0.251

Highest parameter values during test:

V_RMS (Volts): 229.896	Frequency(Hz): 50.00
I_Peak (Amps): 1.849	I_RMS (Amps): 1.130
I_Fund (Amps): 1.115	Crest Factor: 1.647
Power (Watts): 198.7	Power Factor: 0.772

Harm#	Harms(avg)	100%Limit	%of Limit	Harms(max)	150%Limit	%of Limit	Status
2	0.085	1.080	7.9	0.090	1.620	5.5	Pass
3	0.097	2.300	4.2	0.099	3.450	2.9	Pass
4	0.019	0.430	4.4	0.020	0.645	3.1	Pass
5	0.029	1.140	2.5	0.029	1.710	1.7	Pass
6	0.010	0.300	3.2	0.010	0.450	2.3	Pass
7	0.014	0.770	1.8	0.014	1.155	1.3	Pass
8	0.004	0.230	N/A	0.005	0.345	N/A	Pass
9	0.012	0.400	3.0	0.012	0.600	2.1	Pass
10	0.002	0.184	N/A	0.003	0.276	N/A	Pass
11	0.008	0.330	2.6	0.009	0.495	1.9	Pass
12	0.002	0.153	N/A	0.002	0.230	N/A	Pass
13	0.008	0.210	3.6	0.008	0.315	2.6	Pass
14	0.002	0.131	N/A	0.002	0.197	N/A	Pass
15	0.007	0.150	4.8	0.007	0.225	3.3	Pass
16	0.001	0.115	N/A	0.002	0.173	N/A	Pass
17	0.007	0.132	N/A	0.007	0.198	N/A	Pass
18	0.001	0.102	N/A	0.002	0.153	N/A	Pass
19	0.006	0.118	N/A	0.007	0.178	N/A	Pass
20	0.001	0.092	N/A	0.001	0.138	N/A	Pass
21	0.005	0.107	N/A	0.005	0.161	N/A	Pass
22	0.001	0.084	N/A	0.002	0.125	N/A	Pass
23	0.004	0.098	N/A	0.004	0.147	N/A	Pass
24	0.001	0.077	N/A	0.001	0.115	N/A	Pass
25	0.004	0.090	N/A	0.004	0.135	N/A	Pass
26	0.001	0.071	N/A	0.001	0.107	N/A	Pass
27	0.003	0.083	N/A	0.003	0.125	N/A	Pass
28	0.001	0.066	N/A	0.002	0.099	N/A	Pass
29	0.002	0.078	N/A	0.003	0.116	N/A	Pass
30	0.001	0.061	N/A	0.001	0.092	N/A	Pass
31	0.002	0.073	N/A	0.002	0.109	N/A	Pass
32	0.001	0.058	N/A	0.001	0.086	N/A	Pass
33	0.001	0.068	N/A	0.002	0.102	N/A	Pass
34	0.001	0.054	N/A	0.001	0.081	N/A	Pass
35	0.001	0.064	N/A	0.001	0.096	N/A	Pass
36	0.001	0.051	N/A	0.001	0.077	N/A	Pass
37	0.001	0.061	N/A	0.001	0.091	N/A	Pass
38	0.001	0.048	N/A	0.001	0.073	N/A	Pass
39	0.001	0.058	N/A	0.001	0.087	N/A	Pass
40	0.001	0.046	N/A	0.001	0.069	N/A	Pass

2.7 Flicker

2.7.1 Test Method

Flicker test should be conducted with the user's operation controls or automatic programs set to the mode expected to produce the most unfavourable sequence of voltage change, using only those combinations of controls and programmes which are mentioned by the manufacturer in the instruction manual, or are otherwise likely to be used.

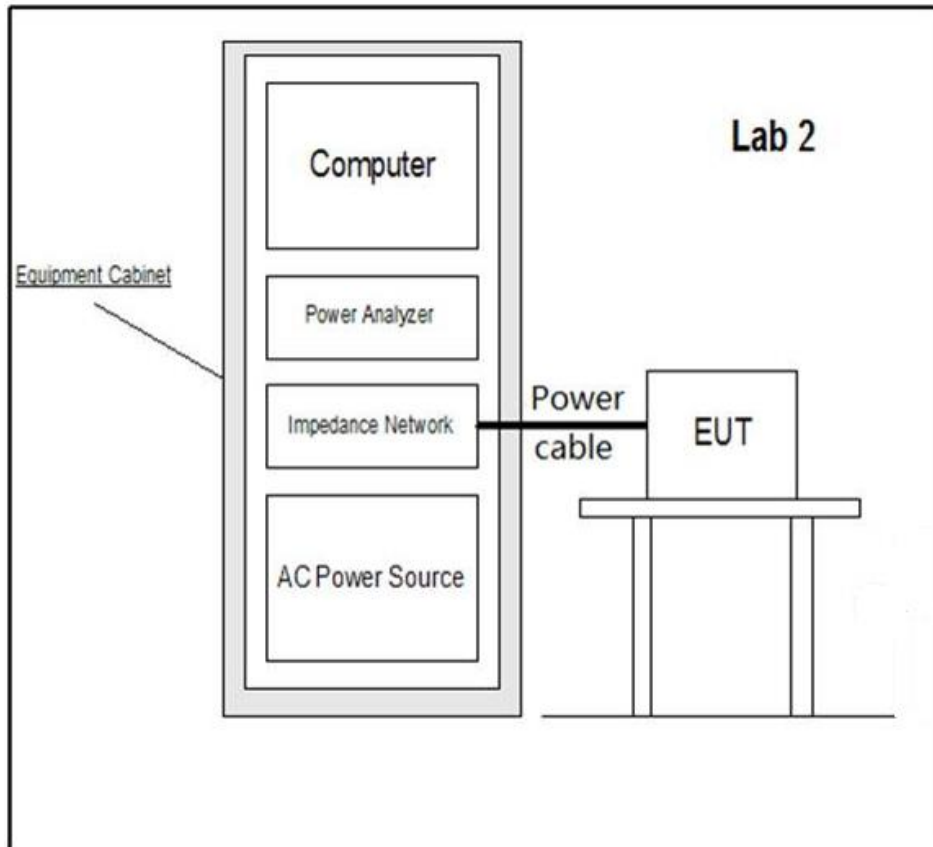

2.7.2 Specification Limits

The value of P_{st} shall not be greater than 1.0

The value of P_{lt} shall not be greater than 0.65

T_{max} , the accumulated time value of $d(t)$ with a deviation exceeding 3.3% during a single voltage change at the EUT terminals, shall not exceed 500ms

The maximum relative steady-state voltage change, d_c , shall not exceed 3.3%

The maximum relative voltage change d_{max} , shall not exceed

- a) 4% without additional conditions
- b) 6% for equipment which is:
 - Switched manually, or
 - Switched automatically more frequently than twice per day, and also has either a delayed start, or manual restart, after a power supply interruption
- c) 7% for equipment which is:
 - Attended whilst in use, or
 - Switched on automatically, or is intended to be switched on manually, no more than twice per day, and also has either a delayed restart or manual restart, after a power supply interruption

2.7.3 Test Setup



2.7.4 Test Location

This test was carried out in Harmonic Flicker Test area.

2.7.5 Test Results

Results for Configuration and Mode: TC1/TM1

Performance assessment of the EUT made during this test: Pass

Detailed results are shown below:

Model : MDDO1-12DEN7-QA3
Test date : 2024-07-13

Standard used: EN/IEC 61000-3-3 Ed.3 Flicker
Short time (Pst): 10 min
Observation time: 120 min (12 Flicker measurements)
Flickermeter: 230V / 50Hz according IEC 61000-4-15 Ed.2
Flicker Impedance: Zref (IEC 60725)

Maximum Flicker results

	EUT values	Limit	Result
Pst	0.323	1.00	PASS
Plt	0.317	0.65	PASS
dc [%]	0.239	3.30	PASS
dmax [%]	2.170	6.00	PASS
Tmax [s]	0.000	0.50	PASS



Model : MDDO-10DEN7-QA3
 Test date : 2024-07-19

Standard used: EN/IEC 61000-3-3 Ed.3 Flicker
 Short time (Pst): 10 min
 Observation time: 120 min (12 Flicker measurements)
 Flickermeter: 230V / 50Hz according IEC 61000-4-15 Ed.2
 Flicker Impedance: Zref (IEC 60725)

Maximum Flicker results

	EUT values	Limit	Result
Pst	0.302	1.00	PASS
Plt	0.298	0.65	PASS
dc [%]	0.239	3.30	PASS
dmax [%]	2.149	6.00	PASS
Tmax [s]	0.000	0.50	PASS

2.8 Electrostatic discharge immunity test

2.8.1 Test Method

The equipment under test including associated cabling was configured on but insulated from, using a 0.5mm isolator, a horizontal coupling plane fitted to the top of a 0.8m non-conductive table for table-top equipment; and on a 0.1m insulated support for floor standing equipment; above a ground reference plane all within a test laboratory.

Using the air discharge method for non-metallic parts, contact discharge method for metallic parts with both vertical and horizontal couple plane discharge methods for the sides of the equipment under test, the required electrostatic discharge voltage levels in both voltage polarities were applied at the detailed pulse repartition rate.

During this testing any anomalies in the equipment under tests performance was recorded.

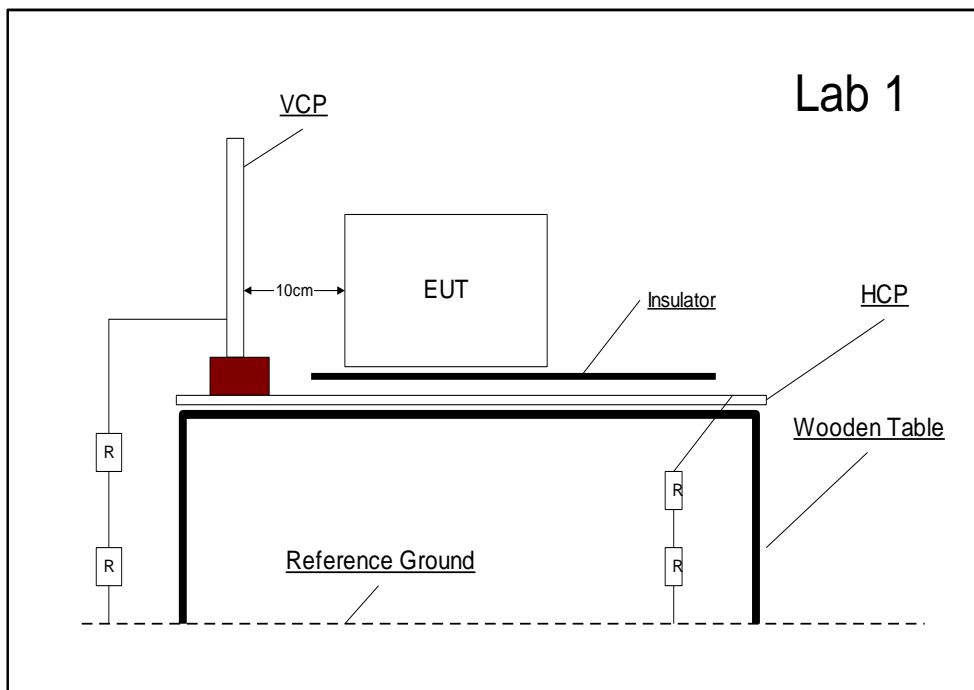

2.8.2 Specification Limits

Discharge type	Required Test Levels		Number of discharges per location (each polarity)	Performance Criteria
	Discharge Level (kV)			
	Positive	Negative		
Air – Direct	8	8	10	B
Contact – Direct	4	4	10	B
Contact – Indirect	4	4	10	B

2.8.3 Test Setup and Test point



Test Setup

X: Contact Discharge, O: Air Discharge



Test point

2.8.4 Test Location

This test was carried out in ESD room.

2.8.5 Test Results

Results for Configuration and Mode: TC1/TM1

Performance assessment of the EUT made during this test: Pass

Detailed results are shown below.

Test date: 2024-07-08, 2024-07-16



Test Point	Discharge	Results: Met Performance Criteria									
		2kV		4kV		6kV		8kV		15kV	
		+	-	+	-	+	-	+	-	+	-
HCP	Contact	N/A	N/A	N/A	N/A	N/A	N/A	N/A	N/A	N/A	N/A
VCP	Contact	N/A	N/A	A	A	N/A	N/A	N/A	N/A	N/A	N/A
Each conductive location touchable by hand	Contact	N/A	N/A	A	A	N/A	N/A	N/A	N/A	N/A	N/A
Each nonconductive location touchable by hand	Air	N/A	N/A	N/A	N/A	N/A	N/A	A	A	N/A	N/A
N/A	Not Appliance										

Remark: No observable change.

2.9 Electrical fast transient /burst immunity test

2.9.1 Test Method

The equipment under test including associated cabling was configured on but insulated from, using a 0.1 m isolator, a horizontal coupling plane fitted to the top of a 0.8 m non-conductive table for table-top equipment; and on a 0.1 m insulated support for floor standing equipment; above a ground reference plane all within a test laboratory.

Using a CDN for power ports, capacitive coupling clamp for signal and control ports and a 33nF coupling capacitor for earth ports, the required fast transient burst voltage levels in both voltage polarities were applied at the detailed pulse repartition rate and duration of test.

During this testing any anomalies in the equipment under tests performance was recorded.

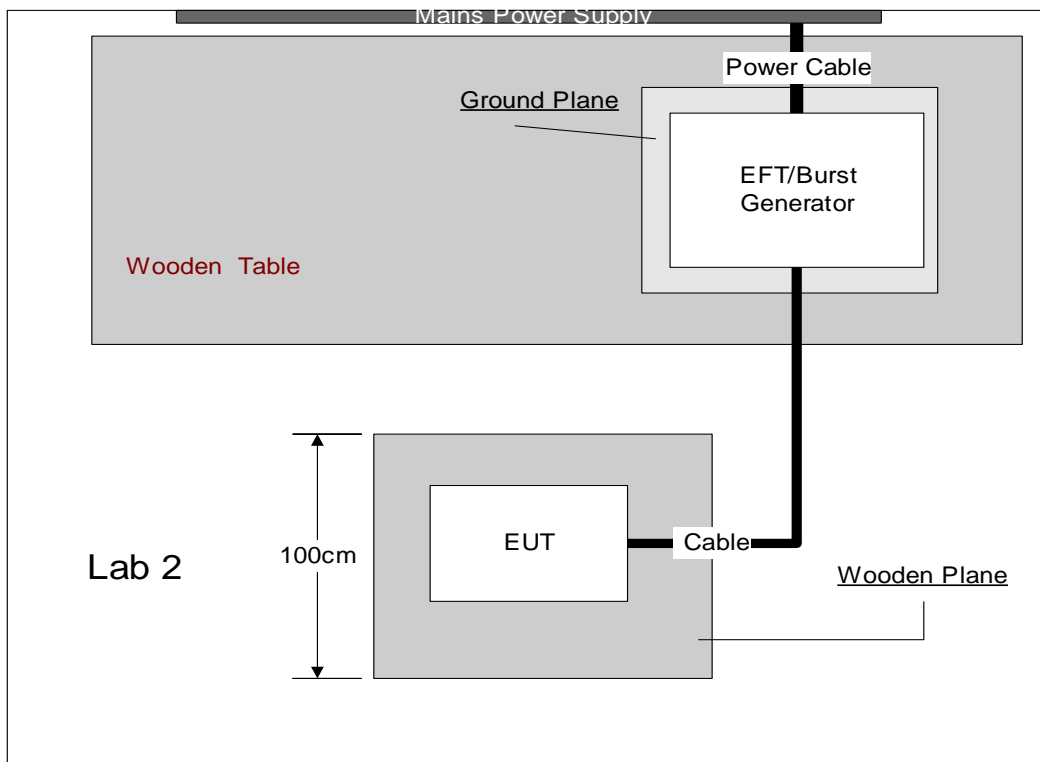

2.9.2 Specification Limits

Required Test Levels Input and output a.c. power ports					Performance Criteria
Line Under Test	Level (kV)	Repetition Rate (kHz)	Test Duration	Coupling Method	
Input and output a.c. power ports	± 1.0	5 kHz	2 min per polarity	Direct	B
For extra low voltage a.c. ports and output a.c. ports, this testing is only applicable to ports interfacing with cables whose total length may exceed 3 m according to the manufacturer's functional specification.					

Required Test Levels ports for signal and control lines					Performance Criteria
Line Under Test	Level (kV)	Repetition Rate (kHz)	Test Duration	Coupling Method	
Signal and control lines	± 0.5	5 kHz	2 min per polarity	Direct/Clamp	B
Applicable only to ports interfacing with cables whose total length can exceed 3m according to the manufacturer's function specification.					

2.9.3 Test Setup



2.9.4 Test Location

This test was carried out in EMS Test Location.



2.9.5 Test Results

Results for Configuration and Mode: TC1/TM1

Performance assessment of the EUT made during this test: Pass

Detailed results are shown below.

Test date: 2024-07-08, 2024-07-13

Tabulated Results for Fast Transient Burst Immunity					
Line under test	Test Level (V/m)	Repetition Rate	Test Duration	Coupling Method	Result
Power line	± 1.0 kV	5 kHz	2 min	CDN	A

Remark: No observable change.

2.10 Immunity to conducted disturbances, induced by radio-frequency fields

2.10.1 Test Method

The equipment under test was configured, on but insulated from, using a 0.1 m isolator, a horizontal coupling plane fitted to the top of a 0.1 m non-conductive table for table-top equipment, above a ground reference plane all within a test laboratory.

All associated cabling was configured, on but insulated from, using a 50 mm isolator, the same horizontal coupling plane as the equipment under test.

Using CDNs, EM Clamps or current clamps as appropriate, the power ports and applicable signal and control ports were subjected to the required, pre calibrated RF injected signal strength, modulated as described, swept over the frequency range of test.

During this testing any anomalies in the equipment under tests performance was recorded.

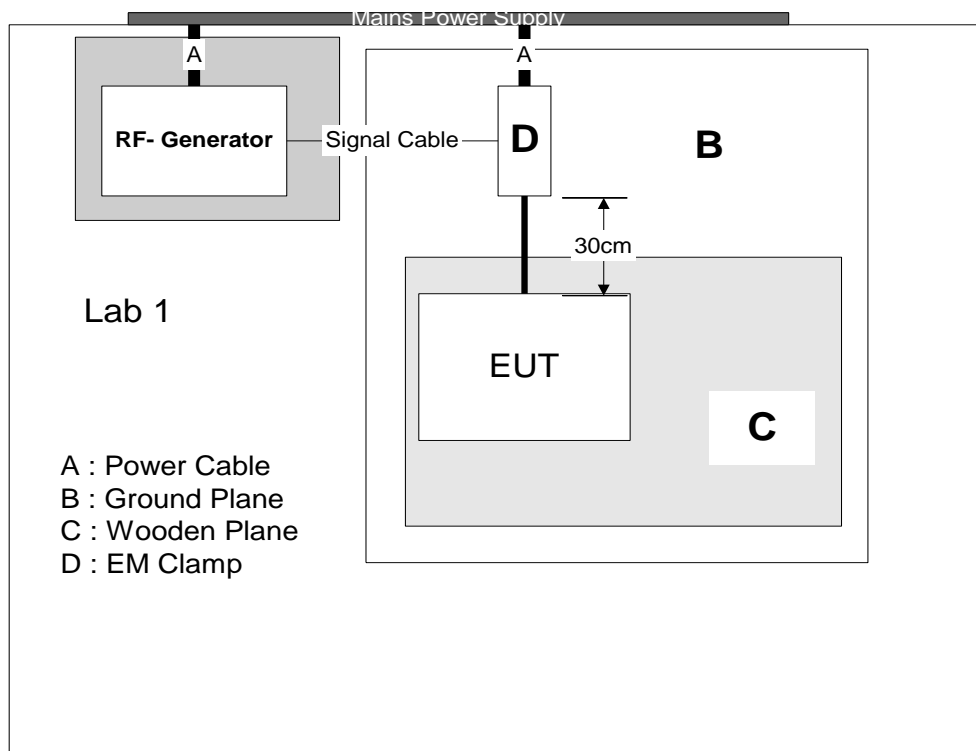

2.10.2 Specification Limits

Required Test Levels Input and output a.c. power ports						Performance Criteria
Line Under Test	Frequency Range (MHz)	Level (V/m)	Modulation	Step Size (%)	Dwell (s)	
Input and output a.c. power ports	0.15 to 230	3	AM (80 %,1 kHz, sine wave)	1	3	A
For extra low voltage a.c ports and output a.c. ports, this testing is only applicable to ports interfacing with cables whose total length may exceed 3 m according to the manufacturer's functional specification.						

Required Test Levels Ports for signal lines and control lines						Performance Criteria
Line Under Test	Frequency Range (MHz)	Level (V/m)	Modulation	Step Size (%)	Dwell (s)	
Signal and control port	0.15 to 230	1	AM (80 %,1 kHz, sine wave)	1	3	A
Applicable only to ports interfacing with cables whose total length may exceed 3m according to the manufacturer's function specification.						

2.10.3 Test Setup



2.10.4 Test Location

This test was carried out in EMS Test Location.



2.10.5 Test Results

Results for Configuration and Mode: TC1/TM1

Performance assessment of the EUT made during this test: Pass

Detailed results are shown below.

Test date: 2024-07-08, 2024-07-13

Tabulated Results for Injected current						
Line and sensitive frequency under test	Test Level	Step	Dwell Time	Coupling Method	Modulation	Result
Power line	3V	1%	3s	CDN	1kHz, 80%	A

Remark: No observable change.

2.11 Radiated, radio-frequency, electromagnetic field immunity test

2.11.1 Test Method

The equipment under test including associated cabling was configured, on a 0.8 m non-conductive table for table-top equipment and on a 0.12 m insulated support for floor standing equipment; with a pre-calibrated semi anechoic chamber.

All four side of the equipment under test were subjected to the required RF field strength, modulated as described, swept over the frequency range of test with the antenna positioned in both horizontal and vertical polarizations.

During this testing any anomalies in the equipment under tests performance was recorded.

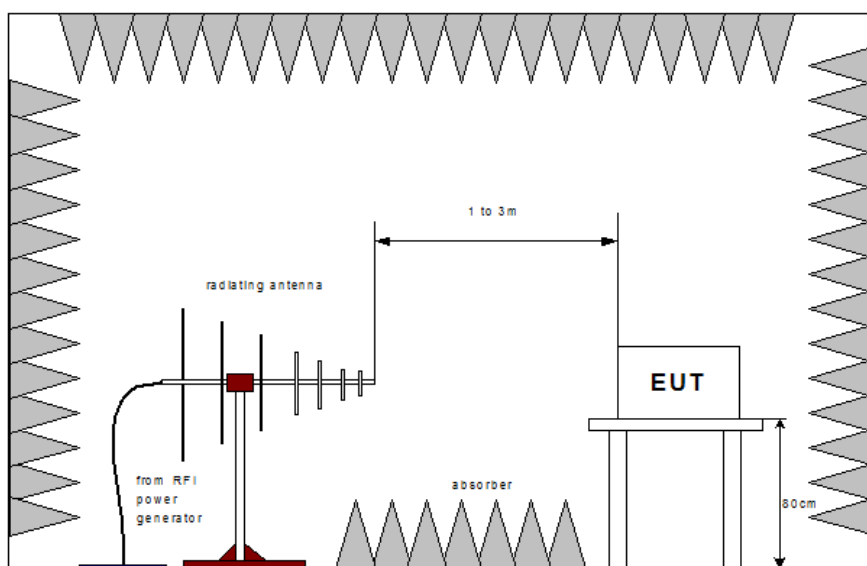

2.11.2 Specification Limits

Required Test Levels					Performance Criteria
Frequency Range (MHz)	Level (V/m)	Modulation	Step Size (%)	Dwell (s)	
80 to 6000	3	AM (80 %,1 kHz, sine wave)	1	1	A
Note 1. EUT powered at one of the Nominal input voltages and frequencies					

2.11.3 Test Setup



2.11.4 Test Location

This test was carried out in RS Test Location.

2.11.5 Test Results

Results for Configuration and Mode: TC1/TM1

Performance assessment of the EUT made during this test: pass

Detailed results are shown below.

Test date: 2024-07-03, 2024-08-02

Tabulated Results for RF Electromagnetic Field 80 - 6000 MHz					
Side of the equipment under test	Antenna polarization	Test Level	Dwell Time	Measuring distance	Results
All sides	Horizontal	3 V/m	1 s	3 m	A
All sides	Vertical	3 V/m	1 s	3 m	A

2.12 Surge immunity test

2.12.1 Test Method

The equipment under test including associated cabling was configured, on a 0.8 m non-conductive table for table-top equipment and on a 0.1 m insulated support for floor standing equipment above a ground reference plane all within a test laboratory.

Using CDNs for power ports and appropriate coupling methods for applicable signal and control ports, the required number of surges was applied for each surge voltage level using both positive and negative surge voltage polarities. Surges were applied at the power line frequency phase angles and repartition rates detailed.

During this testing any anomalies in the equipment under tests performance was recorded.

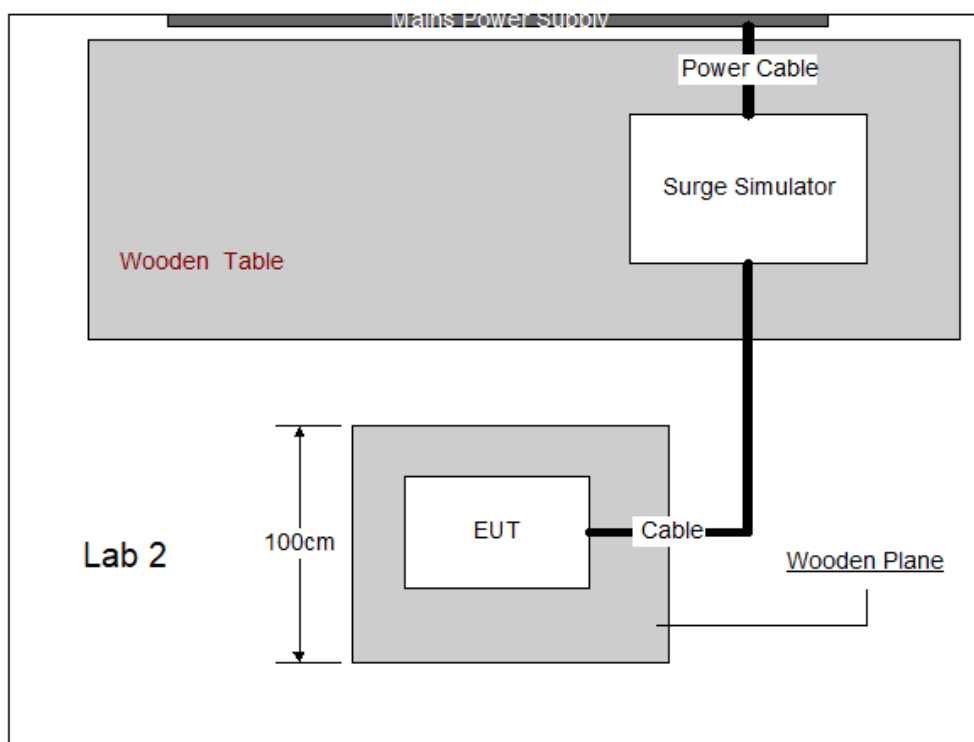

2.12.2 Specification Limits

Characteristics	Test Levels	Performance Criteria
Wave-shape data	1.2/50 μ s	B
Test levels line to line with 2 Ω impedance line to earth with 12 Ω impedance	\pm 1.0 kV \pm 2.0 kV	
Note in addition to the specified test level, all lower levels as detailed in IEC 61000-4-5 should also be satisfied.		

2.12.3 Test Setup



2.12.4 Test Location

This test was carried out in EMS Test Location.

2.12.5 Test Results

Results for Configuration and Mode: TC1/TM1

Performance assessment of the EUT made during this test: Pass

Detailed results are shown below.

Test date: 2024-07-13

Tabulated Results for Surge Immunity (Power Ports)							
Line Name	Coupling	Level	Polarity	Phase Angle	No of Pulses	Repetition Rate	Result
Power line	Live to Neutral	1.0kV	Negative	0,90,180, 270 deg	5	60 sec	A
Power line	Live to Neutral	1.0kV	Positive	0,90,180, 270 deg	5	60 sec	A
Power line	Live to Earth	2.0kV	Negative	0,90,180, 270 deg	5	60 sec	A
Power line	Live to Earth	2.0kV	Positive	0,90,180, 270 deg	5	60 sec	A
Power line	Neutral to Earth	2.0kV	Negative	0,90,180, 270 deg	5	60 sec	A
Power line	Neutral to Earth	2.0kV	Positive	0,90,180, 270 deg	5	60 sec	A

Remark: No observable change.

2.13 Voltage dips, short interruptions and voltage variations immunity tests

2.13.1 Test Method

The equipment under test including associated cabling was configured, on a 0.8 m non-conductive table for table-top equipment and on a 0.1 m insulated support for floor standing equipment above a ground reference plane all within a test laboratory.

Using a programmable power supply the equipment under test was subjected to the detailed supply voltage dips and interruptions. The required supply phase synchronization and test repetition rate, detailed, was controlled by the programmable power supply.

During this testing any anomalies in the equipment under tests performance was recorded.

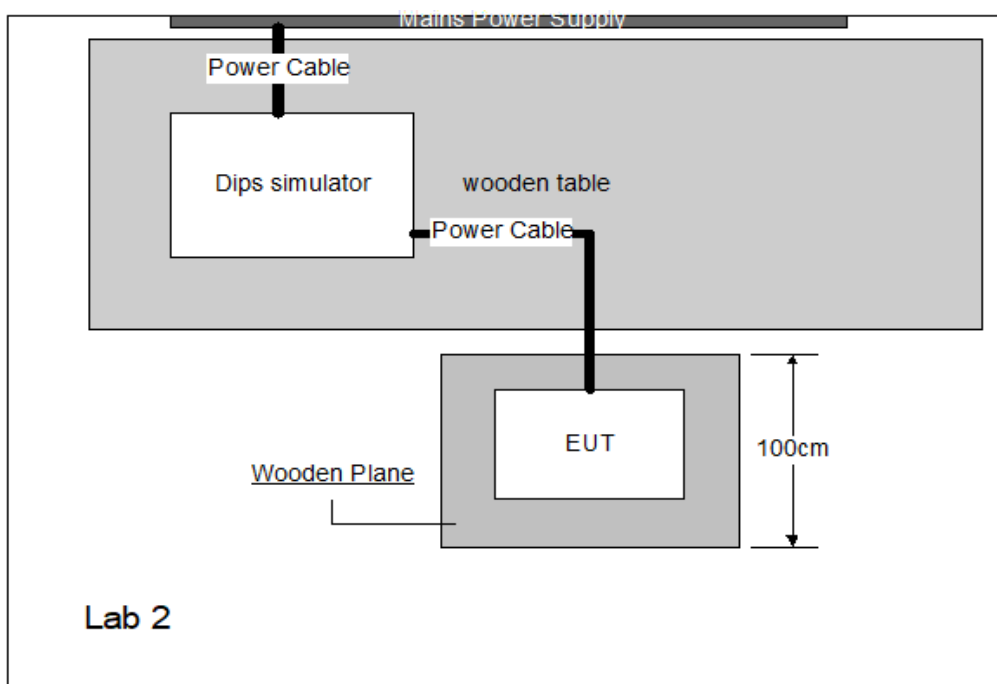

2.13.2 Specification Limits

Voltage Dips				
Voltage Dips in % UT	Test level in % UT	Duration		Performance Criteria
		50Hz	60Hz	
100	0	½ cycle	½ cycle	C
100	0	0 cycles	0 cycles	C
100	0	250 cycles	300 cycles	C
60	40	10 cycles	12 cycles	C
30	70	25 cycles	30 cycles	C

UT is the rated voltage of the Equipment Under Test

2.13.3 Test Setup



2.13.4 Test Location

This test was carried out in EMS Test Location.

2.13.5 Test Results

Results for Configuration and Mode: TC1/TM1

Performance assessment of the EUT made during this test: Pass

Detailed results are shown below.

Test date: 2024-07-13

Tabulated Results for Voltage Dip and Short Interruption					
Line under test	Vnom	Operating Frequency	Test Level	Duration	Result
Power line	230 V~	50 Hz	0% of Vnom	½ cycle	B
Power line	230 V~	50 Hz	0% of Vnom	1 cycles	B
Power line	230 V~	50 Hz	0% of Vnom	250 cycles	B
Power line	230 V~	50 Hz	40% of Vnom	10 cycles	B
Power line	230 V~	50 Hz	70% of Vnom	25 cycles	A

Remark: “B” During the test, the EUT stopped and restarted automatic after testing.

3 Test Equipment Information

3.1 General Test Equipment Used

Test Site 1:

Conducted Emission Test

DESCRIPTION	MANUFACTURER	MODEL NO.	SERIAL NO.	CAL INTERVAL (YEAR)	CAL. DUE DATE
EMI Test Receiver	Rohde & Schwarz	ESCI	101380	1	2025-01-15
LISN	Rohde & Schwarz	NNLK8121	8121-636	1	2025-01-15
Pulse limiter	Rohde & Schwarz	ESH3-Z2	101903	1	2025-01-15
Passive voltage probe	Rohde & Schwarz	ESH3-Z3	100610	1	2024-11-01

Discontinuous Emission Test

DESCRIPTION	MANUFACTURER	MODEL NO.	SERIAL NO.	CAL INTERVAL (YEAR)	CAL. DUE DATE
LISN	AFJ	NNLK8121	8121-636	1	2025-01-15
Click Analysis	AFJ	AFJDDA55	14041605036	1	2025-06-18
Testing Software	AFJ	AFJ Click Meter Software CMS version 4.19	N/A	N/A	N/A

Harmonic Test / Flicker Test

DESCRIPTION	MANUFACTURER	MODEL NO.	SERIAL NO.	CAL INTERVAL (YEAR)	CAL. DUE DATE
Harmonic and Flicker test system	EM TEST	DPA503N/AI F503N32.1	P1342125054 /P141313294 1	1	2025-04-30
AC Power source	EM TEST	ACS503N30	P1421134515	1	2025-01-10
Testing Software	EM TEST	dpa.control version 5.4.11.0	N/A	N/A	N/A
AC power source	TESEQ	NSG1007-60-400	1605A03180/1611S02896	1	2024-11-02
Harmonic and Flicker Analyzer System	TESEQ	INA2197 NA2196 CCN 1000-3-75	1607A00622 1606A03019 1606A02959	1	2025-03-08
Testing Software	TESEQ	AMETEK Programmable Power CTS MXL2 V2.26.0 ($\leq 16A$) AMETEK Programmable Power CTS MXH2 V2.24.0 ($> 16A$)	N/A	N/A	N/A



Electrostatic Discharge Test(ESD area)

DESCRIPTION	MANUFACTURE R	MODEL NO.	SERIAL NO.	CAL INTER VAL (YEAR)	CAL. DUE DATE
ESD Simulator System	Teseq	NSG437	1084	1	2025-07-14

Electrical Fast Transients Test(EMS area)

DESCRIPTION	MANUFACTURE R	MODEL NO.	SERIAL NO.	CAL INTER VAL (YEAR)	CAL. DUE DATE
Burst Generator	TESEQ	NSG 3040A-EFT	P2139256704	1	2024-11-02
CDN	TESEQ	CDN 3043A-C32	P2130254756	1	2024-11-02
EM clamp	EM test	CCI	P1827221598	1	2024-10-06
Testing Software	EM test	IEC.CONTR OL version 10.1.3	N/A	N/A	N/A

Surges Test(EMS area)

DESCRIPTION	MANUFACTURE R	MODEL NO.	SERIAL NO.	CAL INTER VAL (YEAR)	CAL. DUE DATE
Burst Generator	TESEQ	NSG 3060	1833	1	2025-01-10
CDN	TESEQ	CDN 3063	2206	1	2025-01-10
Testing Software	TESEQ	Version 002.35	N/A	N/A	N/A

Conducted Immunity Test(EMS area)

DESCRIPTION	MANUFACTURER	MODEL NO.	SERIAL NO.	CAL INTER VAL (YEAR)	CAL. DUE DATE
RF-Generator	EM test	NSG-4070	63293	1	2024-08-23
CDN	EM test	CDN M3-32	1315117315	1	2024-10-06
Attenuator	Shanghai Huaxiang	WDTS100-6DB-2.5G-C	16120201	1	2024-10-06
Testing Software	EM test	NSG 4070 Control Version:1.3.1 .2	N/A	N/A	N/A

Variation of power frequency Test(EMS area)

DESCRIPTION	MANUFACTURER	MODEL NO.	SERIAL NO.	CAL INTER VAL (YEAR)	CAL. DUE DATE
Voltage dip test system	Teseq	NSG2200-3	1607A01980	1	2025-03-08
AC source	CI	TSGC2-33	SN2015.5.1	1	2025-03-13
Testing Software	Teseq	Win 2120 ver 3.00	N/A	N/A	N/A

Test Site 2 :**Radiated Emission Test (SAC-3 area)**

DESCRIPTION	MANUFACTURER	MODEL NO.	EQUIPMENT ID	SERIAL NO.	CAL INTER VAL (YEAR)	CAL. DUE DATE
EMI Test Receiver	Rohde & Schwarz	ESR 26	64-2-63-20-003	101702	1	2025-04-07
Trilog Super Broadband Test Antenna	Schwarzbeck	VULB 9162	64-2-62-22-011	00562	1	2024-10-15
Horn Antenna	Schwarzbeck	BBHA 9120D	64-2-62-20-004	02152	1	2024-11-30
Active Loop Antenna	Schwarzbeck	FMZB 1513-60	64-2-62-21-012	00041	1	2024-11-21
Pre-amplifier	Rohde & Schwarz	SCU08F1	64-2-28-20-010	101016	1	2024-11-06
Pre-amplifier	Rohde & Schwarz	SCU 18	64-2-28-20-011	100759	1	2024-11-06
Testing Software	R&S	EMC32 (Version: 10.60.20)	64-2-26-20-006	N/A	N/A	N/A
3m Semi-anechoic chamber	TDK	SAC-3	64-2-90-20-004	----	3	2026-09-04

Radiated Immunity Test(CAC-3 area)

DESCRIPTION	MANUFACTURER	MODEL NO.	EQUIPMENT ID	SERIAL NO.	CAL INTERVAL (YEAR)	CAL. DUE DATE
Signal Generator	Rohde & Schwarz	SMB100B	64-2-64-20-001	101903	1	2024-11-06
Power Amplifier	Rohde & Schwarz	BBA150-BC500	64-2-28-20-002	104061	1	2024-11-06
Power Amplifier	Rohde & Schwarz	BBA150-D110E100	64-2-28-20-003	104048	1	2024-11-06
Microwave Log-Periodic Antenna	Schwarzbeck	STLP9129 SET	64-2-62-20-002	3074	1	N/A
Average Power Sensor	Rohde & Schwarz	NRP6AN	64-2-32-20-001	101424	1	2024-11-06
Average Power Sensor	Rohde & Schwarz	NRP6AN	64-2-32-20-002	101425	1	2024-11-06
Testing Software	R&S	EMC32 (Version: 10.60.20)	64-2-26-20-003	N/A	N/A	N/A
3m FAC Chamber	TDK	CAC-3	64-2-90-20-003	--	3	2026-09-05



4 Measurement Uncertainty

For a 95% confidence level, the measurement uncertainties for defined systems are:

Test Site 1:

System Measurement Uncertainty	
Test Items	Extended Uncertainty
Uncertainty for Conducted Emission 150kHz-30MHz	2.74dBuV, k=2
Uncertainty for Power Clamp test	3.16 dBpW, k=2
Uncertainty for Harmonic test	5.88%, k=2
Uncertainty for Flicker test	0.272%, k=2
Uncertainty for ESD test	The immunity measurement system uncertainty is within standard requirement and is based on a standard uncertainty multiplied by a coverage factor k=2, providing a level of confidence of approximately 95%.
Uncertainty for EFT test	
Uncertainty for Surges test	
Uncertainty for Voltage Dips, Voltage Variations and Short Interruptions Test	

Test Site 2:

System Measurement Uncertainty	
Test Items	Extended Uncertainty
Uncertainty for Radiated Emission in 3m chamber 30MHz-1000MHz	Horizontal: 5.13dB Vertical: 5.20dB
Uncertainty for Radiated Emission in 3m chamber 1000MHz-18000MHz	Horizontal: 5.02dB Vertical: 5.02dB
Uncertainty for RS test	2.08dB, K=2

Remark:

Measurement Uncertainty Decision Rule

Determination of conformity with the specification limits is based on the decision rule according to IEC Guide 115: 2023, clause 4.3.3.

5 Photographs

Details of: MDDO1-12DEN7-QA3



Details of: MDDO1-12DEN7-QA3



Details of: MDDO1-12DEN7-QA3

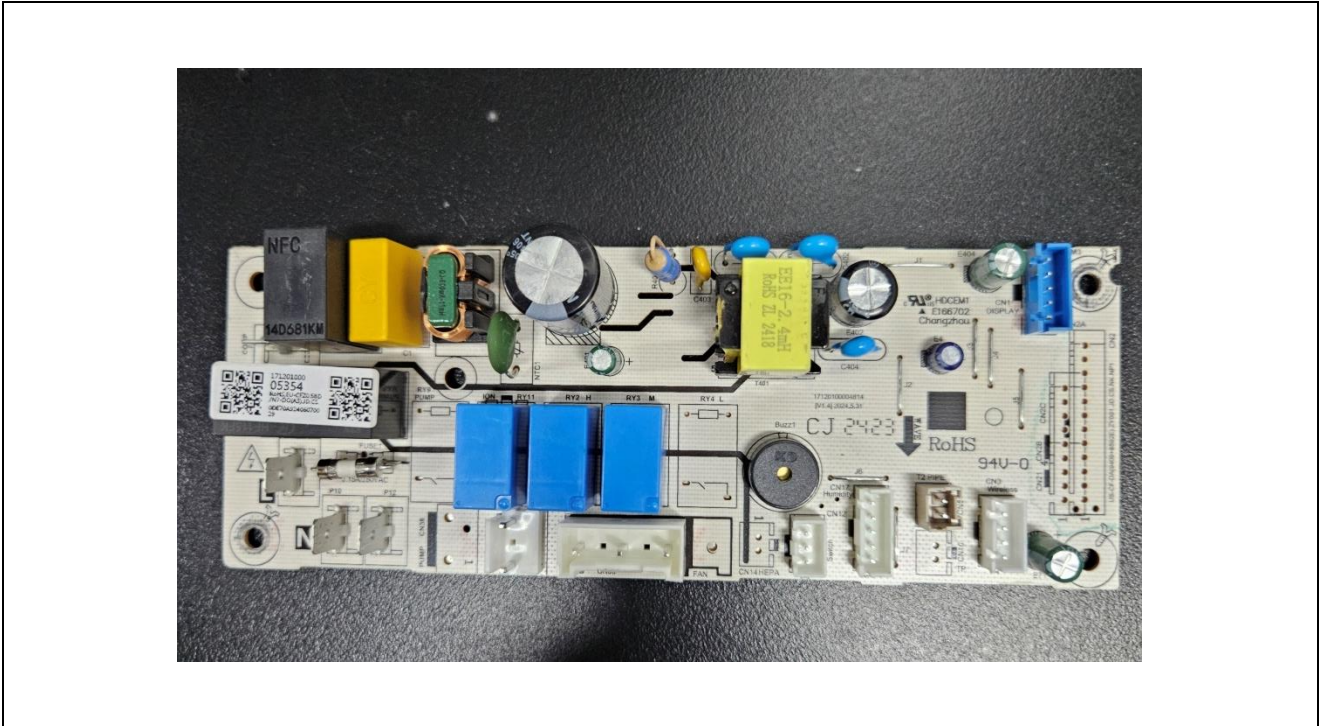

Details of: MDDO1-12DEN7-QA3

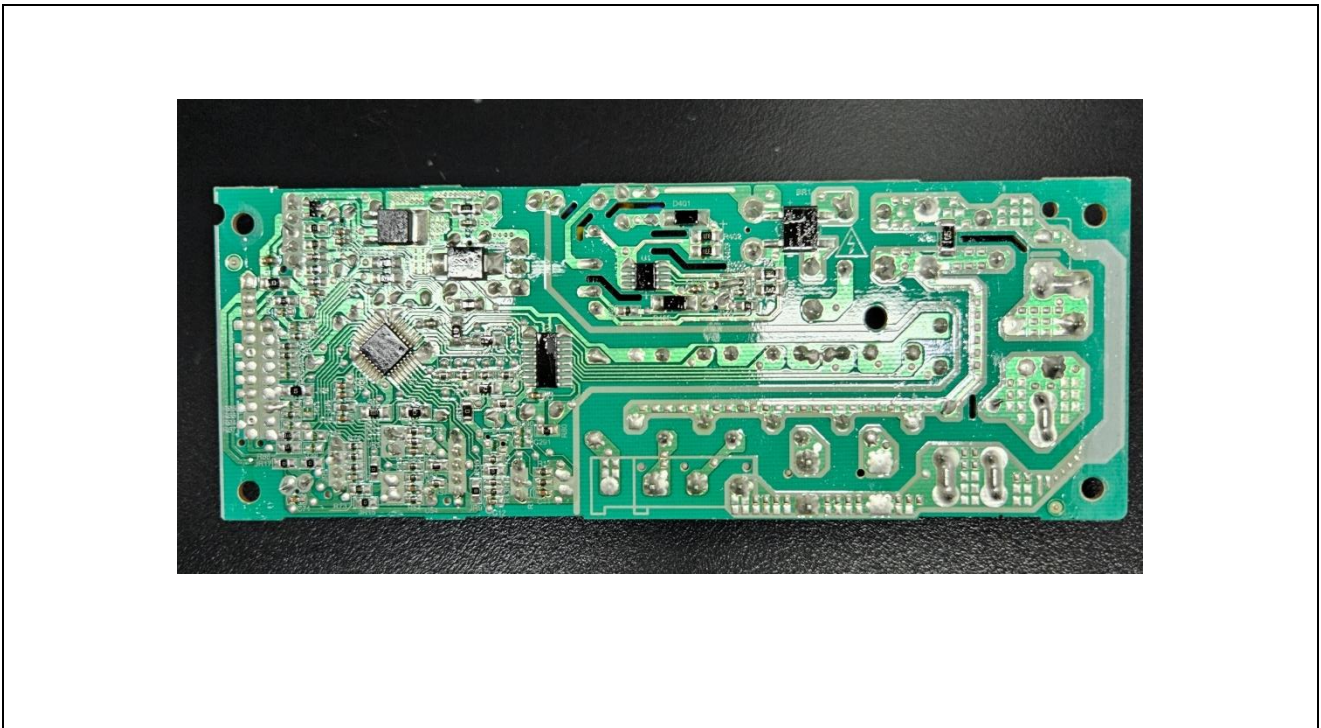

Details of: MDDO-12DEN7-QA3



Details of: MDDO-12DEN7-QA3

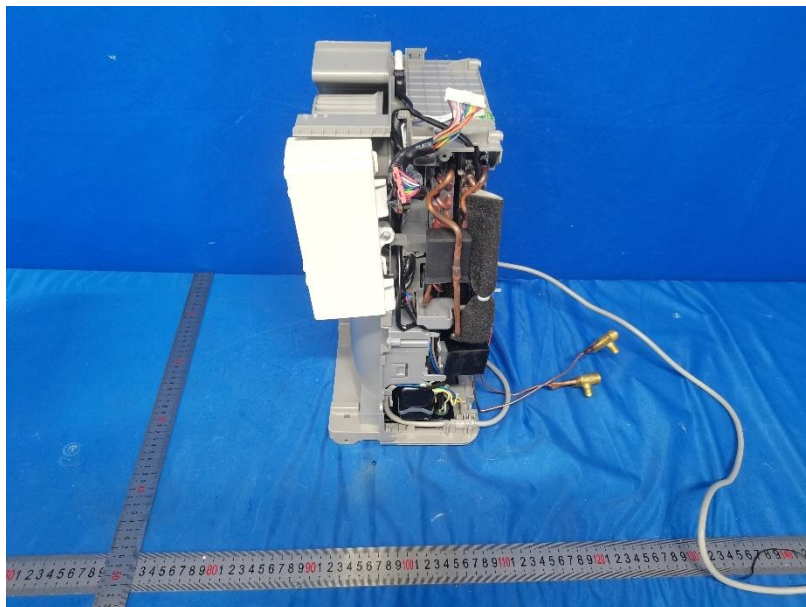

Details of: MDDO-12DEN7-QA3

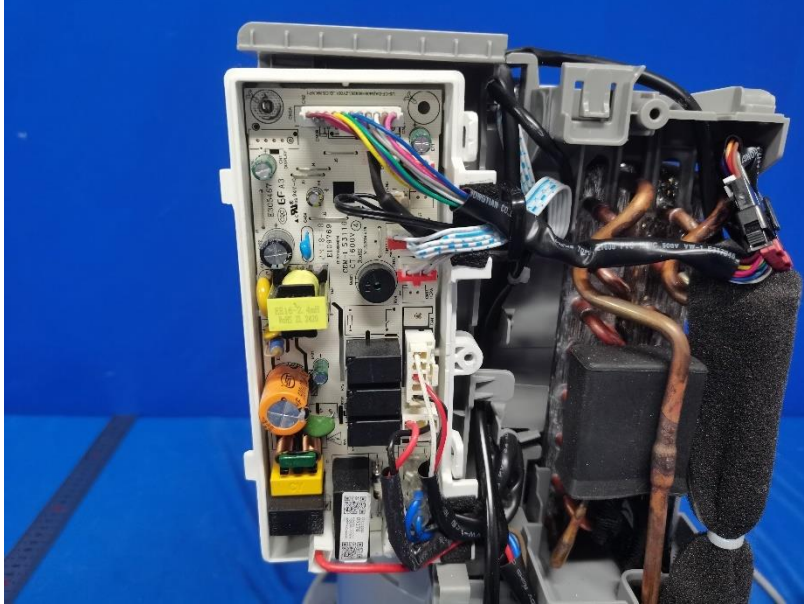

Details of: MDDO-12DEN7-QA3

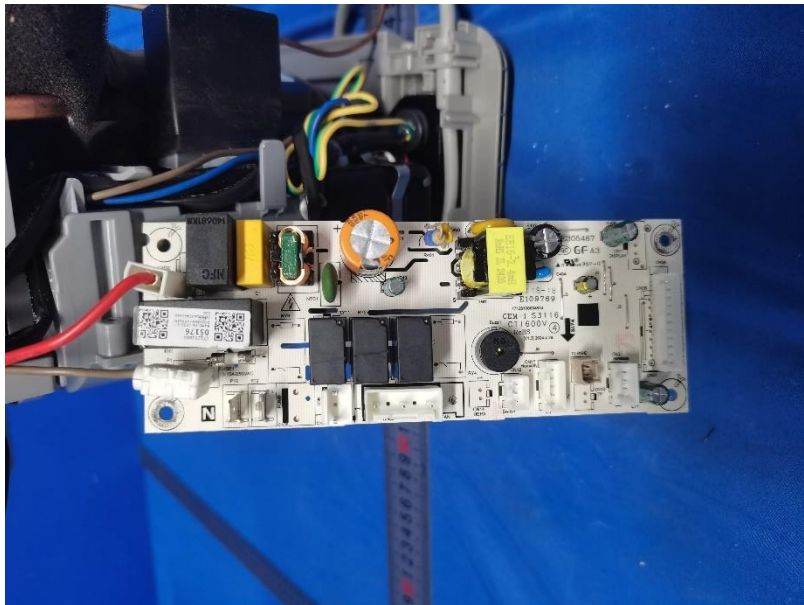

Details of: MDDO-12DEN7-QA3

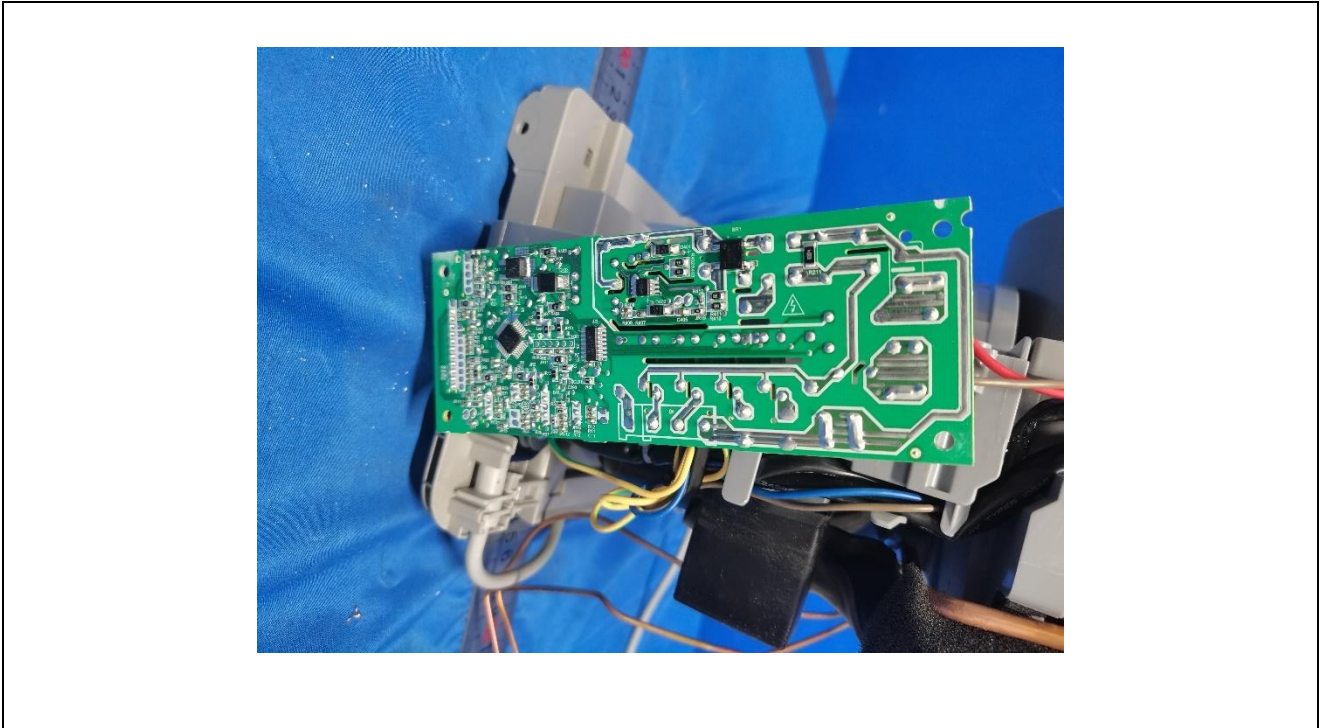

Details of: MDDO-12DEN7-QA3



Details of: MDDO-12DEN7-QA3

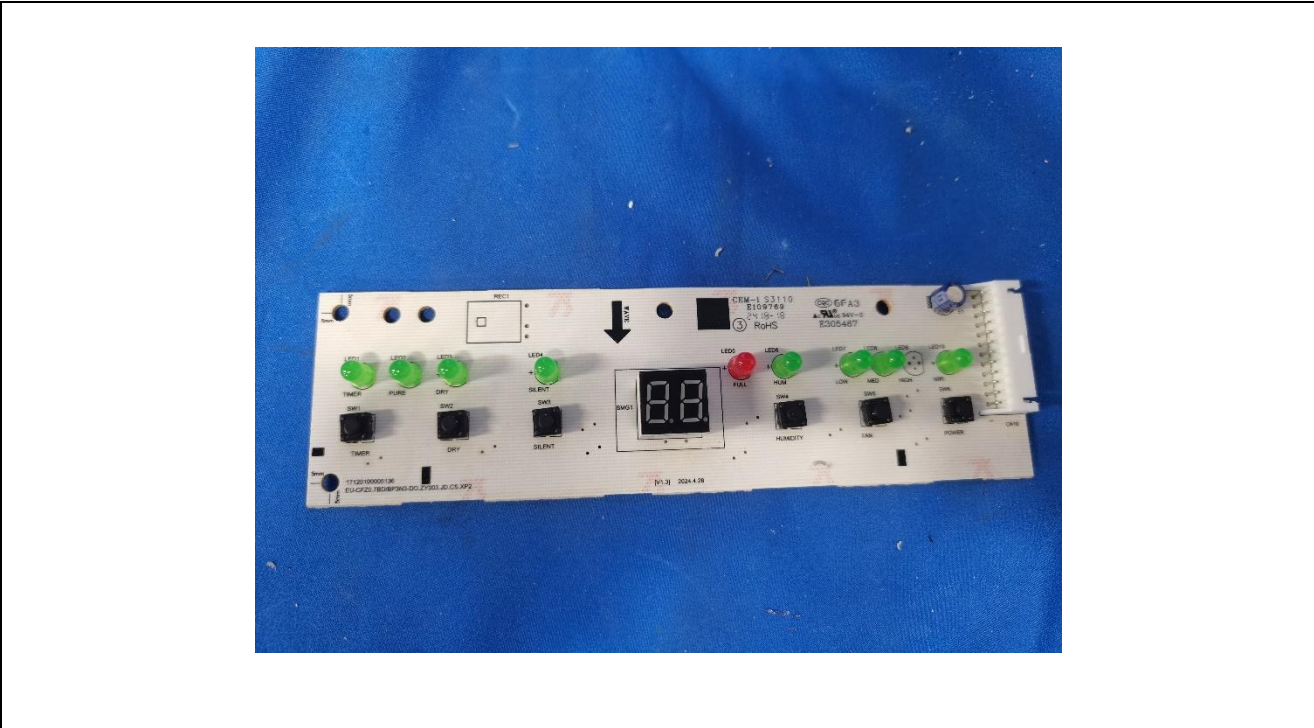

Details of: MDDO-12DEN7-QA3



Details of: Fan motor



Details of: Alternative fan motor



Details of: MDDO-10DEN7-QA3



Details of: MDDO-10DEN7-QA3



Details of: MDDO-10DEN7-QA3

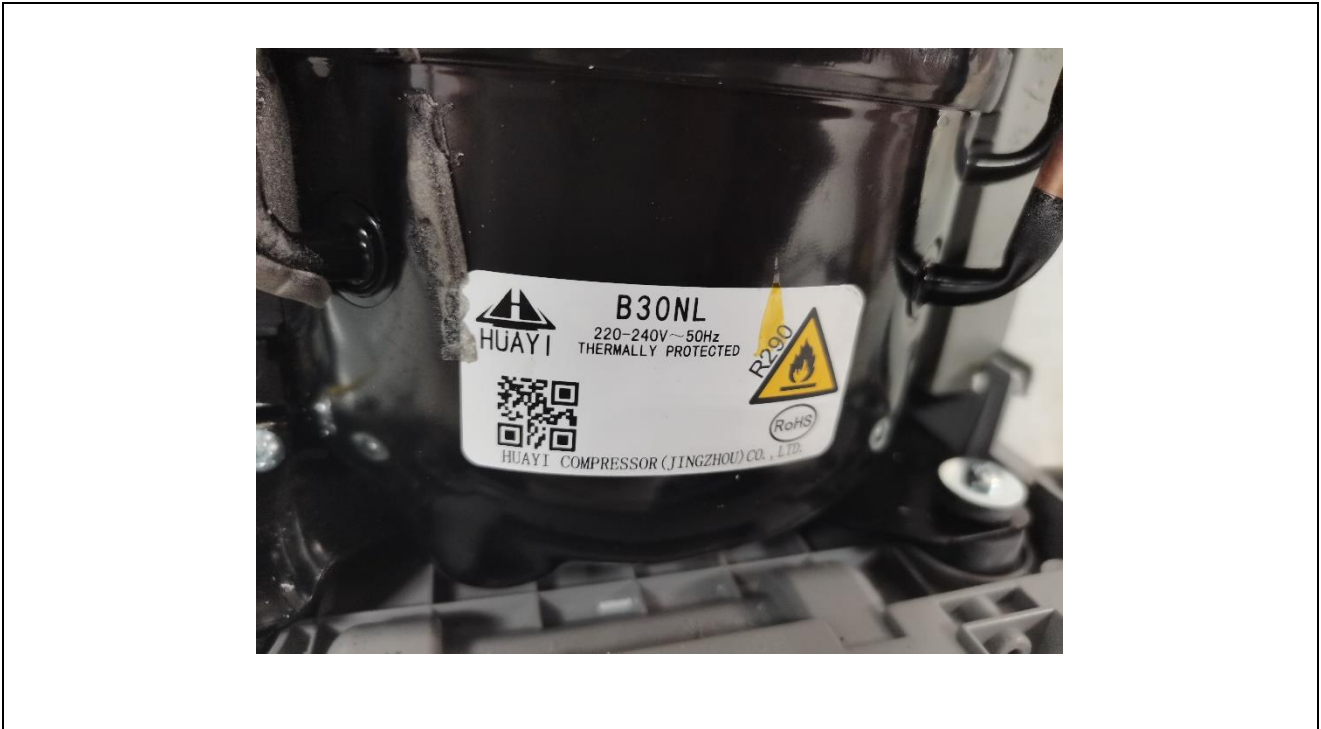

Details of: MDDO-10DEN7-QA3

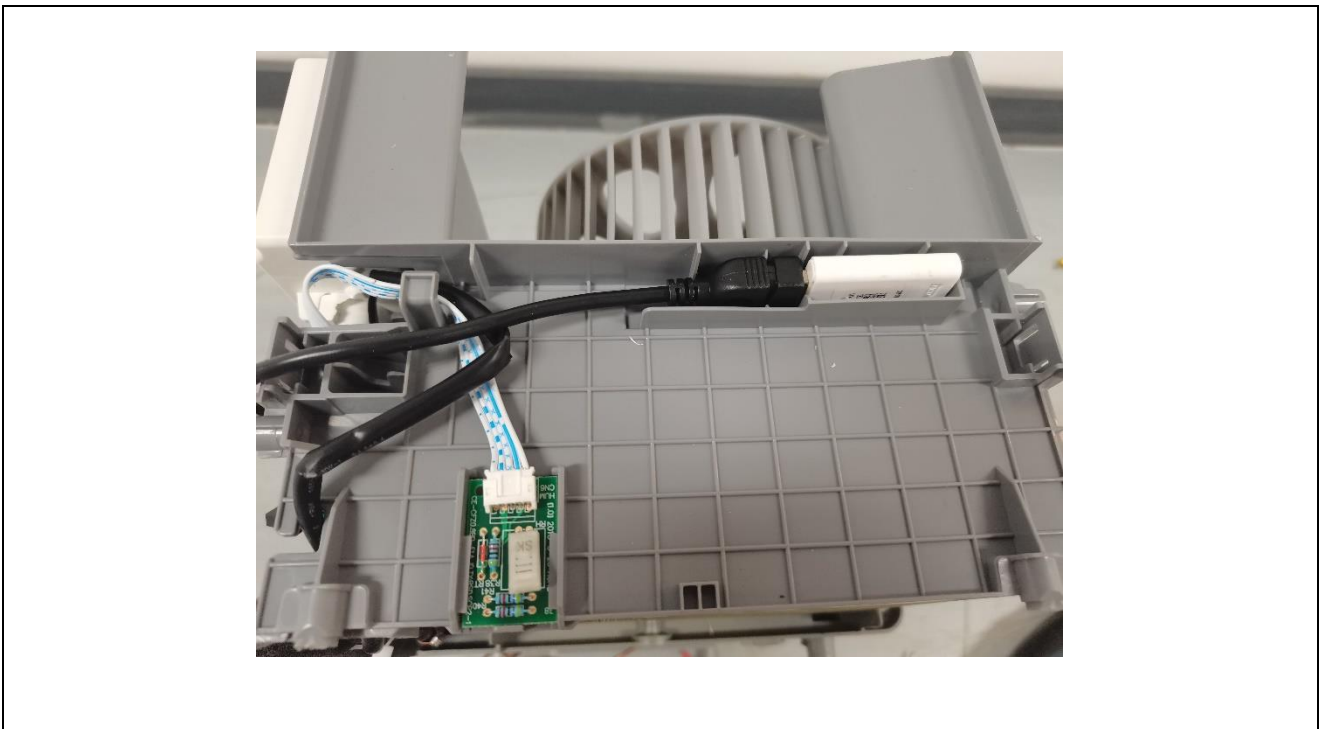

Details of: MDDO1-10DEN7-QA3



Details of: MDDO1-10DEN7-QA3



Details of: WI-FI module



Details of: WI-FI module

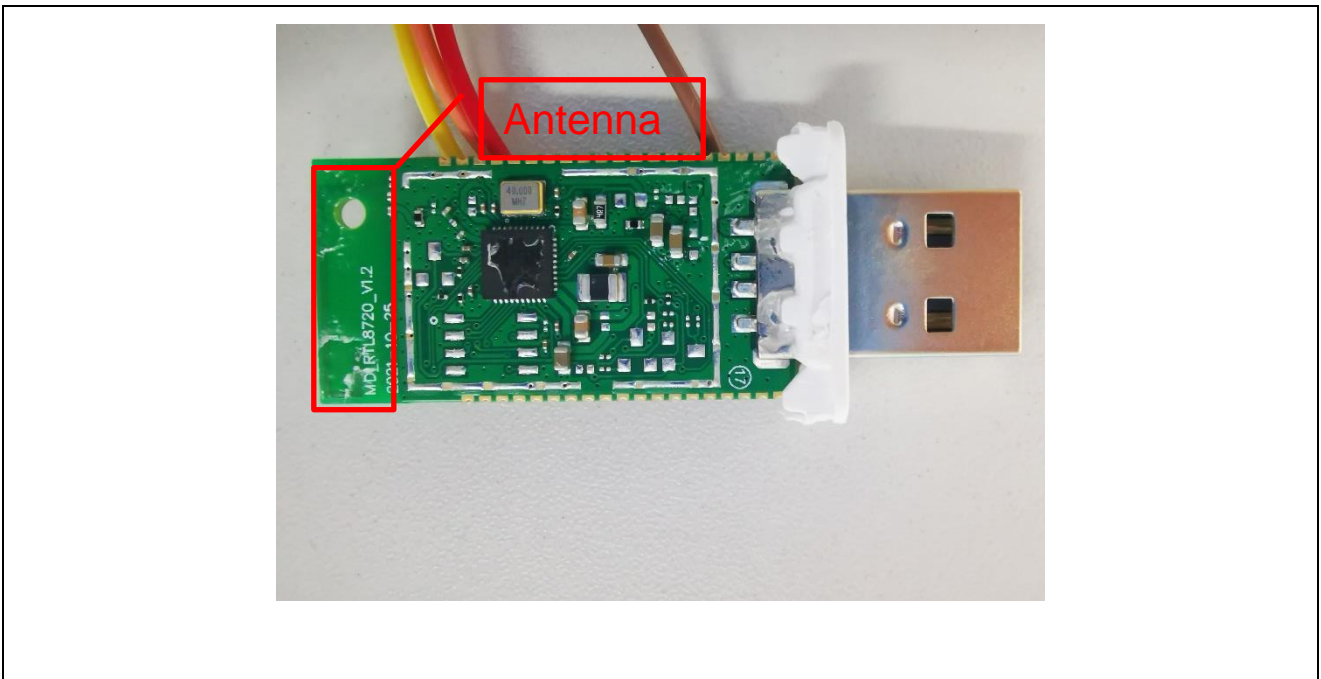

Details of: WI-FI module

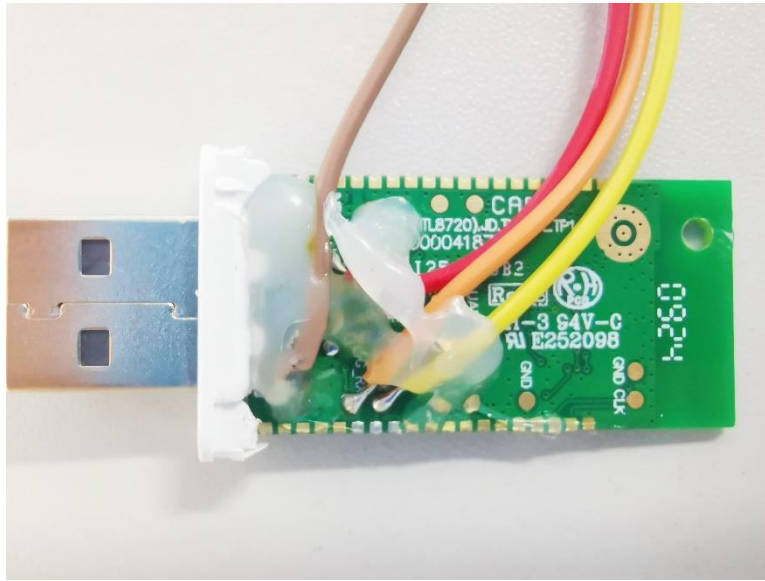

---END---