

ASSEMBLY INSTRUCTIONS

ANNIE TUFTED CHAIR

ASSEMBLY REQUIREMENTS

1-Person
Assembly

Assembly Time
Per Chair (Approximate)

30 MINUTES

Tools Required
(Not Provided)

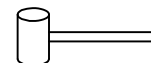

Thank you for purchasing our product!

Please refer and use this assembly instruction to assemble the product.
Contact our customer service department in case there are any missing or damage parts or hardware, Replacement parts are normally shipped within 2 or 3 days.

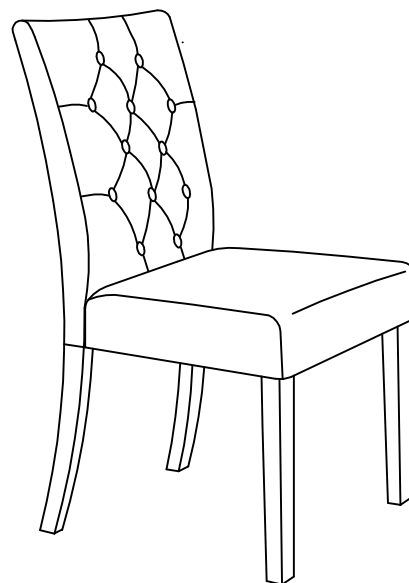

ASSEMBLY PREPARATION

1. Remove all packaging materials, staples and packing straps from the carton.
2. Refer to Parts List and Hardware List and ensure parts and hardware are correct before assembly. Contact customer service for missing parts.
3. Place all wooden parts on a clean, flat and soft surface (e.g. carpet or rug) to prevent scratch and damage to parts.

SAFETY PRECAUTION:

1. KEEP ALL HARDWARE PARTS OUT OF REACH OF CHILDREN.
2. DISPOSE PLASTIC PACKAGING MATERIAL IMMEDIATELY TO AVOID ANY RISK OF SUFFOCATION TO CHILDREN AND ANIMALS.

TIPS FOR ASSEMBLY:

1. Allow ample room for assembly and in close proximity to where product will be placed.
2. Assemble the product on a surface that does not scratch or damage the exterior gloss and finish of the furniture.
3. Identify all of the parts, hardware and quantities required for each step.
4. During assembly, do not over-tighten any fittings as this may cause damage.
5. DO NOT USE POWER TOOLS TO ASSEMBLE THIS PRODUCT.
6. Always place the product on a flat, level surface.
7. Do not sit or stand on the partially assembled product; only use the product for which it is intended.

CARE AND MAINTENANCE

- Use a slightly damp cloth to clean the product. Do not use bleach or abrasive cleaning material.
- Check all the fittings periodically and re-tighten as necessary . Do not use the product if any of the parts is damaged or broken.
- Never allow any kind of liquid to remain on your furniture. Absorption can cause wood to warp or delaminate.
- Do not place hot items (e.g. hot drinks) directly onto the wood surface.
- Do not drag and / or pull the furniture.

This product is for indoor and household use only - not for commercial use.







ASSEMBLY INSTRUCTIONS

ANNIE TUFTED CHAIR

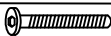
PARTS LIST (FOR 2 COMPLETE CHAIR)

NO.	COMPONENT	QTY
P1	CHAIR BACK	2
P2	CHAIR SEAT	2
P3	FRONT LEG	4

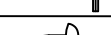
HARDWARE LIST (FOR 2 COMPLETE CHAIR)

NO.	DESCRIPTION	QTY	EXTRA
H1	JCBC SCREW M6 x 80mm 	8	1
H2	JCBC SCREW M6 x 60mm 	8	1
H3	JCBC SCREW M6 x 40mm 	4	1
H4	SPRING WASHER 	20	2
H5	FLAT WASHER 	20	2
H6	ALLEN KEY 	1	
H7	LEG STUD 	8	2

* EXTRA HARDWARE FOR SPARE USE*

STEP 1

- Lay Chair Back (P1) flat down on a material that does not scratch or damage the part.
- Place Chair Seat (P2) on Chair Back (P1) as shown and align the middle screw holes on each part.
- Insert JCBC Screw (H3) fitted with Spring Washer (H4) and Flat Washer (H5) into middle screw hole. Use Allen Key (H6) to drive (H3) into (P1). Do not tighten (H3) completely at this time.

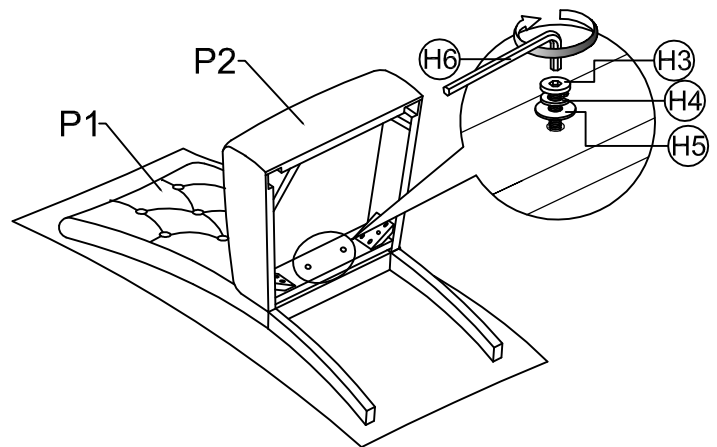

*Take Care not to exert pressure on Chair Back(P1)
Exerting pressure on Chair Back in this position can cause irreparable damage.

STEP 2

- At the rear, right corner of Chair Seat (P2), align the screw holes on the corner block to the screw holes on the right, rear leg.
- Insert JCBC Screw (H1) fitted with Spring Washer (H4) and Flat Washer (H5) into each of the screw hole. Use Allen Key (H6) to drive (H1) into the rear, right leg. Do not tighten (H1) completely at this time.
- Repeat the above assembly procedures at the rear, left corner of Chair Seat (P2).
- Tighten all of the JCBC Screw (H1 & H3) used in step 1 & 2 - do not over-tighten.

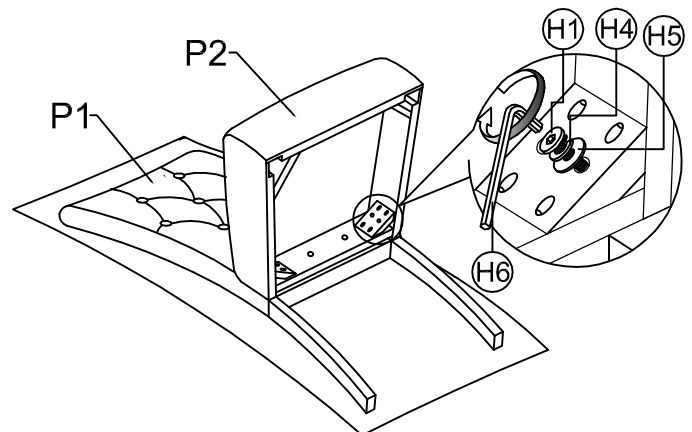

*Take Care not to exert pressure on Chair Back(P1)
Exerting pressure on Chair Back in this position can cause irreparable damage.

ASSEMBLY INSTRUCTIONS

ANNIE TUFTED CHAIR ITEM#92018GRY PR

STEP 3

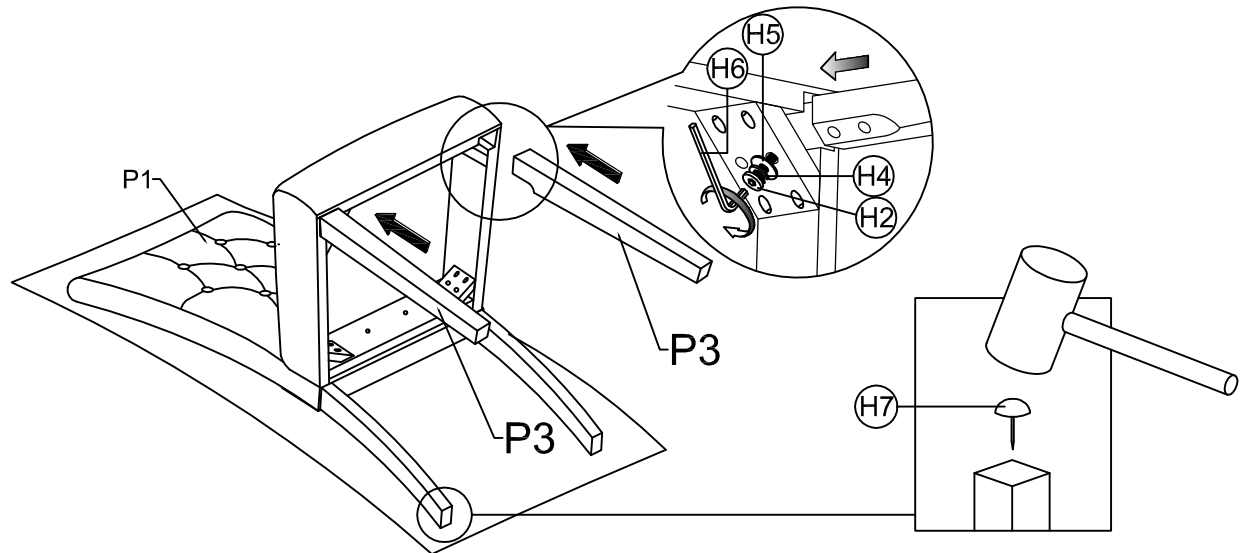

- Place Front Leg (P3) as shown. Align the screw holes on (P3) to the screw holes on front corner block of (P2). Insert JCBC Screw (H2) fitted with Spring Washer (H4) and Flat Washer (H5) into each of the screw hole on the corner block. Use Allen Key (H6) to drive (H2) to fasten (P3) to (P2). Do not tighten (H2) completely until both (H2) are in place - do not over-tighten.
- Use the same assembly procedure above to install the other Front Leg.
- Use a mallet or hammer to gently nail Leg Stud (H7) into each end of the leg.

*Take care not to exert pressure on Chair Back (P1).
Exerting pressure on Chair Back in this position can cause irreparable damage.