

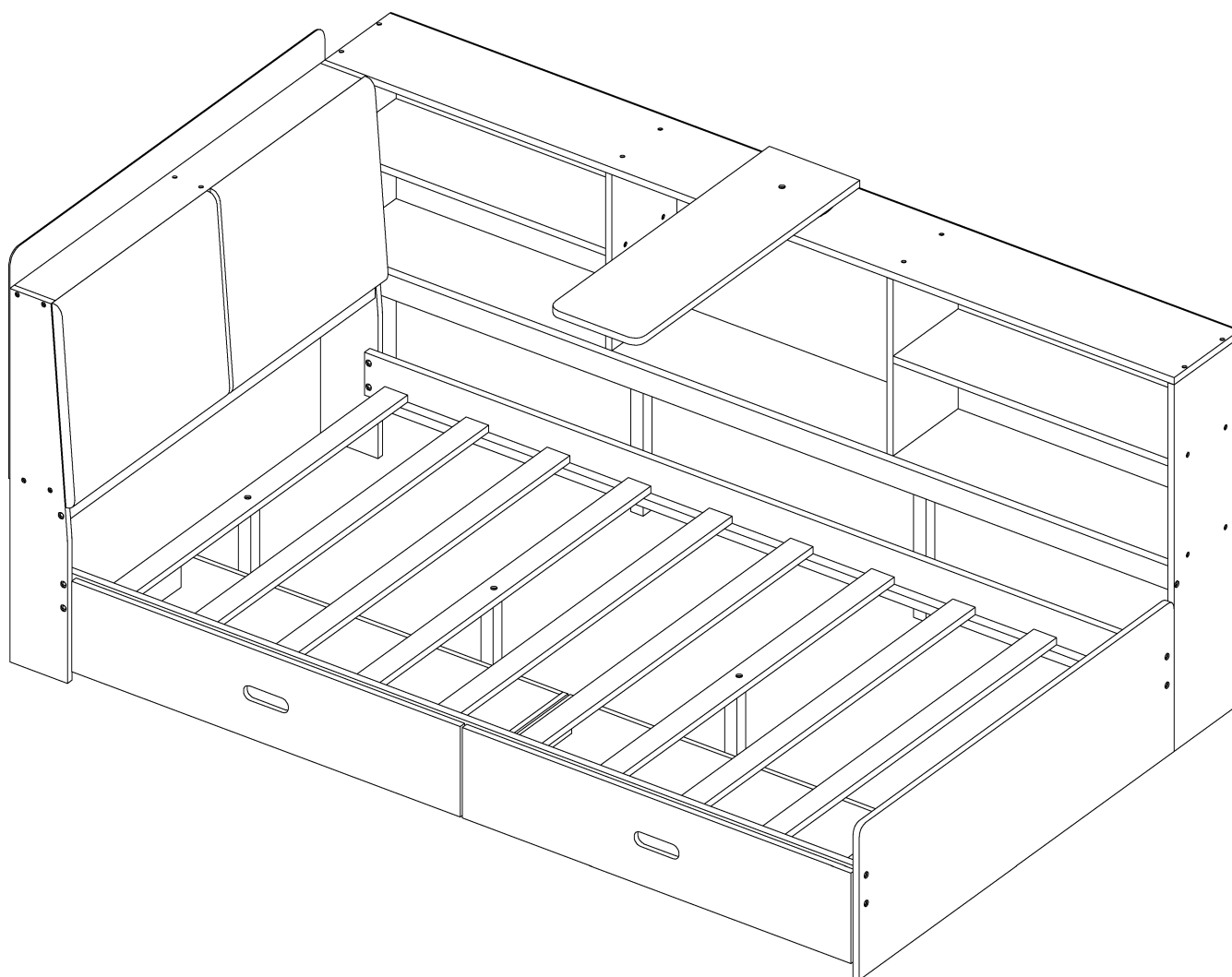

ASSEMBLY INSTRUCTION
INSTRUCTIONS DE MONTAGE

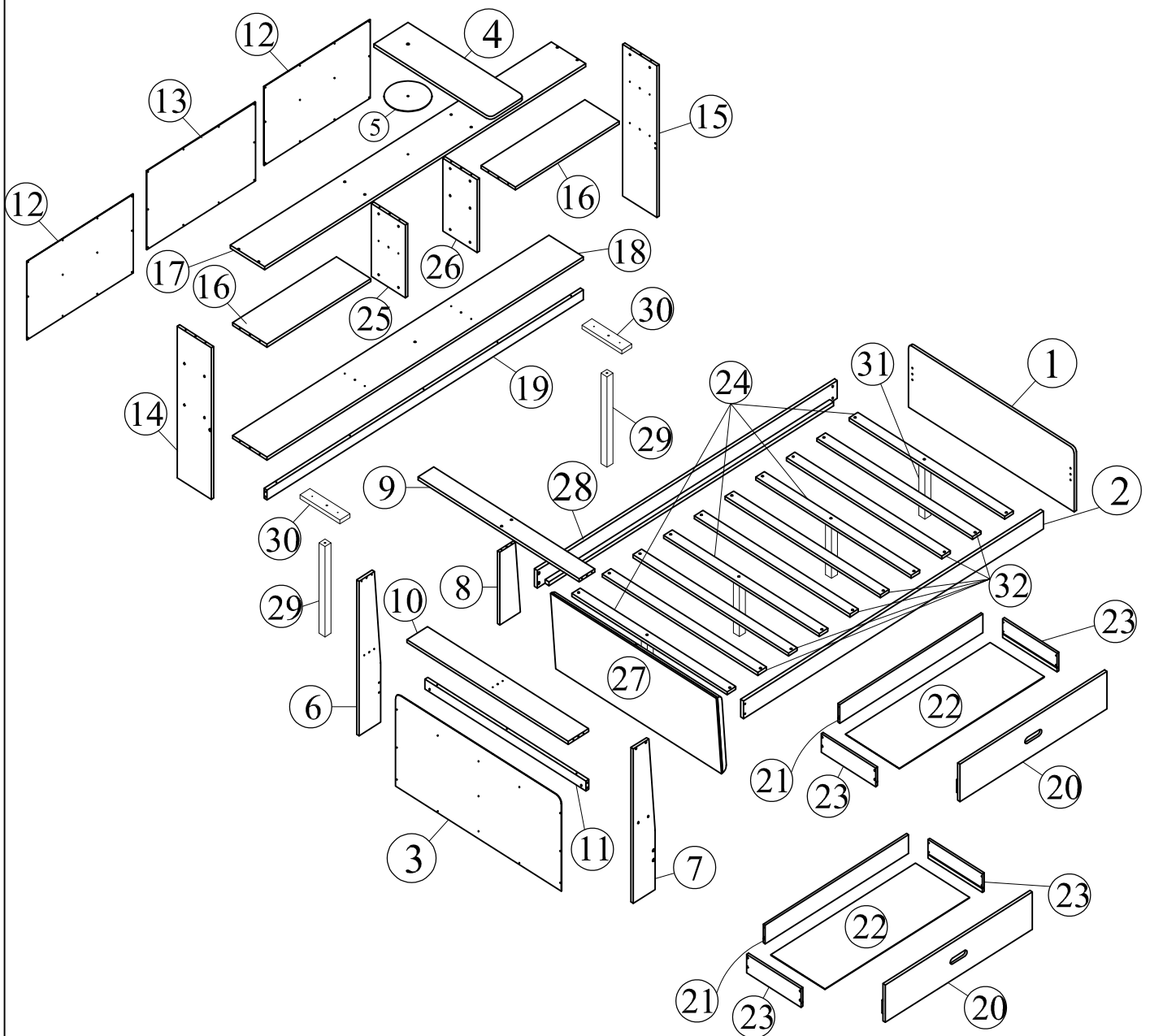



Detail:
Détail::

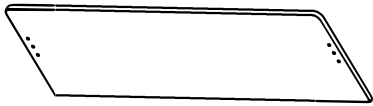
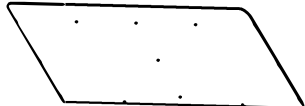
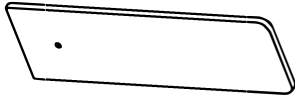
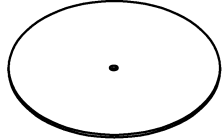
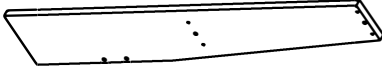

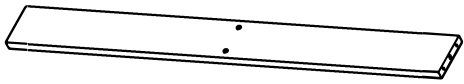
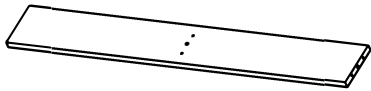
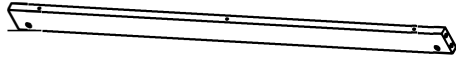
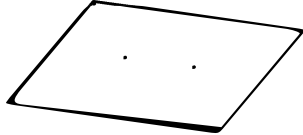
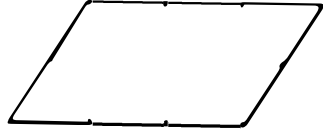
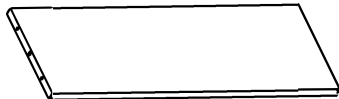
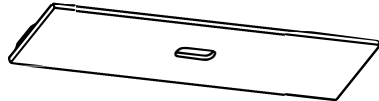



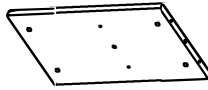
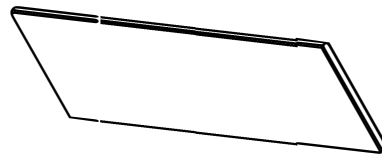
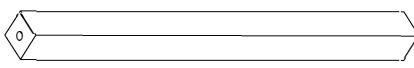
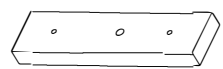
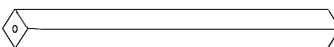

Part List - Liste des pièces

<p>① x1 </p> <p style="text-align: center;">Panel at Footboard Panneau au pied de lit</p>	<p>③ x1 </p> <p style="text-align: center;">Panel at Headboard Panel at Headboard</p>
<p>④ x1 </p> <p style="text-align: center;">Panel Panneau</p>	<p>⑤ x1 </p> <p style="text-align: center;">Cirde panel Panneau Cirde</p>
<p>⑥ x1 </p> <p style="text-align: center;">Left panel at side rail Panneau gauche sur le rail latéral</p>	<p>⑦ x1 </p> <p style="text-align: center;">Right panel at side rail Panneau droit sur le rail latéral</p>
<p>⑧ x1 </p> <p style="text-align: center;">Bulk head Tête en vrac</p>	<p>⑨ x1 </p> <p style="text-align: center;">Top wood bar at headboard Barre supérieure en bois à la tête de lit</p>
<p>⑩ x1 </p> <p style="text-align: center;">Center wood bar of side rail Barre de bois centrale du rail latéral</p>	<p>⑪ x1 </p> <p style="text-align: center;">Bottom panel at side rail Panneau inférieur au rail latéral</p>
<p>⑫ x2 </p> <p style="text-align: center;">Back panel of side rail Panneau arrière du rail latéral</p>	<p>⑬ x1 </p> <p style="text-align: center;">Back panel of side rail Panneau arrière du rail latéral</p>
<p>⑯ x2 </p> <p style="text-align: center;">Shelf Étagère</p>	<p>⑳ x2 </p> <p style="text-align: center;">Front Drawer Tiroir avant</p>

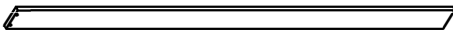

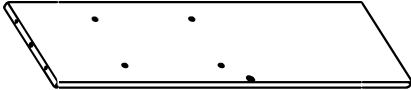
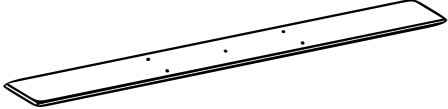
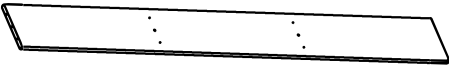

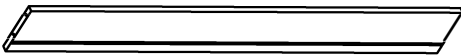

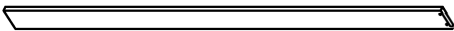
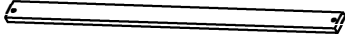



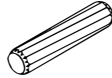

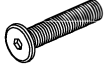

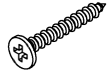
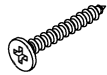
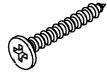

Part List - Liste des pièces

<p>②② x2</p>  <p>Bottom Drawer Tiroir du bas</p>	<p>②⑤ x1</p>  <p>Left Center panel Panneau central gauche</p>
<p>②⑥ x1</p>  <p>Right center panel Panneau central droit</p>	<p>②⑦ x1</p>  <p>Panel at headboard Panneau à la tête de lit</p>
<p>②⑨ x2</p>  <p>Support Leg Jambe de soutien</p>	<p>③① x2</p>  <p>Wooden support additional legs Pieds supplémentaires de support en bois</p>
<p>③① x4</p>  <p>Support Leg Jambe de soutien</p>	

Part List - Liste des pièces

<p>② x1 </p> <p style="text-align: center;">Front side rail Rail latéral avant</p>	<p>⑭ x1 </p> <p style="text-align: center;">Left panel Panneau gauche</p>
<p>⑮ x1 </p> <p style="text-align: center;">Right panel Panneau droit</p>	<p>⑰ x1 </p> <p style="text-align: center;">Top shelf of side rail Tablette supérieure du rail latéral</p>
<p>⑱ x1 </p> <p style="text-align: center;">Bottom shelf of side rail Tablette inférieure du rail latéral</p>	<p>⑲ x1 </p> <p style="text-align: center;">Wood bar at side rail Barre en bois sur le rail latéral</p>
<p>⑳ x2 </p> <p style="text-align: center;">Back Drawer Tiroir arrière</p>	<p>㉓ x4 </p> <p style="text-align: center;">Side panel of drawer Panneau latéral du tiroir</p>
<p>㉔ x4 </p> <p style="text-align: center;">Slats Lattes</p>	<p>㉘ x1 </p> <p style="text-align: center;">Back side rail Rail latéral arrière</p>
<p>㉚ x6 </p> <p style="text-align: center;">Slats Lattes</p>	



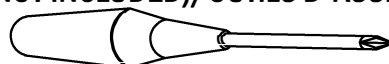

Hardware List - Liste du matériel

No/Non	OUTLOO/PERSPECTIVES	DESC/DESC	QTY/QTÉ
A		Dowel Ø8*30mm Cheville Ø8*30mm	24pcs 24 pièces
B		Bolts M6*60mm Boulons M6*60mm	8pcs 8pièces
C		Bolts M6*20mm Boulons M6*20mm	5pcs 5pièces
D		Bolts M6*15mm Boulons M6*15mm	5pcs 5pièces
E		Cross dowel M6*13mm Cheville croisée M6*13mm	8pcs 8pièces
F		Cross dowel Ø10*10mm Cheville croisée Ø10*10mm	36pcs 36pièces
G		Flat head screw #8*60mm Vis à tête plate #8*60mm	36pcs 36pièces
H		Flat head screw #8*50mm Vis à tête plate #8*50mm	8pcs 8pièces
I		Flat head screw #8*30mm Vis à tête plate #8*30mm	40pcs 40pièces
J		Flat head screw #7*12mm Vis à tête plate #7*12mm	22pcs 22pièces
K		Metal Rectangle Rectangle en métal	1pc 1pièce
L		Pas L Pas L	2pcs 2pièces
M		Flap fitting (Left) Ferrure d' abattant (Gauche)	1pc 1pièce
N		Flap fitting (Right) Ferrure de volet (Droite)	1pc 1pièce
O		Door Hinge Charnière de porte	3pcs 3pièces
P		Wheels roues	8pcs 8pièces
Q		Allen key 60*22*4mm Clé Allen 60*22*4mm	1pc 1pièce
X		Round head screw #8*15mm Vis à tête ronde #8*15mm	47pcs 47pièces

ASSEMBLY TOOLS REQUIRED (NOT INCLUDED)/OUTILS D'ASSEMBLAGE REQUIS (NON INCLUS)



Hardware List - Liste du matériel

No/Non	OUTLOO/PERSPECTIVES	DESC/DESC	QTY/QTÉ
(Y)		Inhaler magnet Aimant pour inhalateur	2pcs 2 pièces
(T)		Flat head screw #7*15mm Vis à tête plate #7*15mm	4pcs 4pièces
(W)		Flat head screw #6*15mm Vis à tête plate #6*15mm	12pcs 12pièces
(Z)		Bolts M6*30mm Boulons M6*30mm	6pcs 6pièces
(S)		Flat head screw #8*25mm Vis à tête plate #8*25mm	16pcs 16pièces



ASSEMBLY TOOLS REQUIRED (NOT INCLUDED)/OUTILS D'ASSEMBLAGE REQUIS (NON INCLUS)

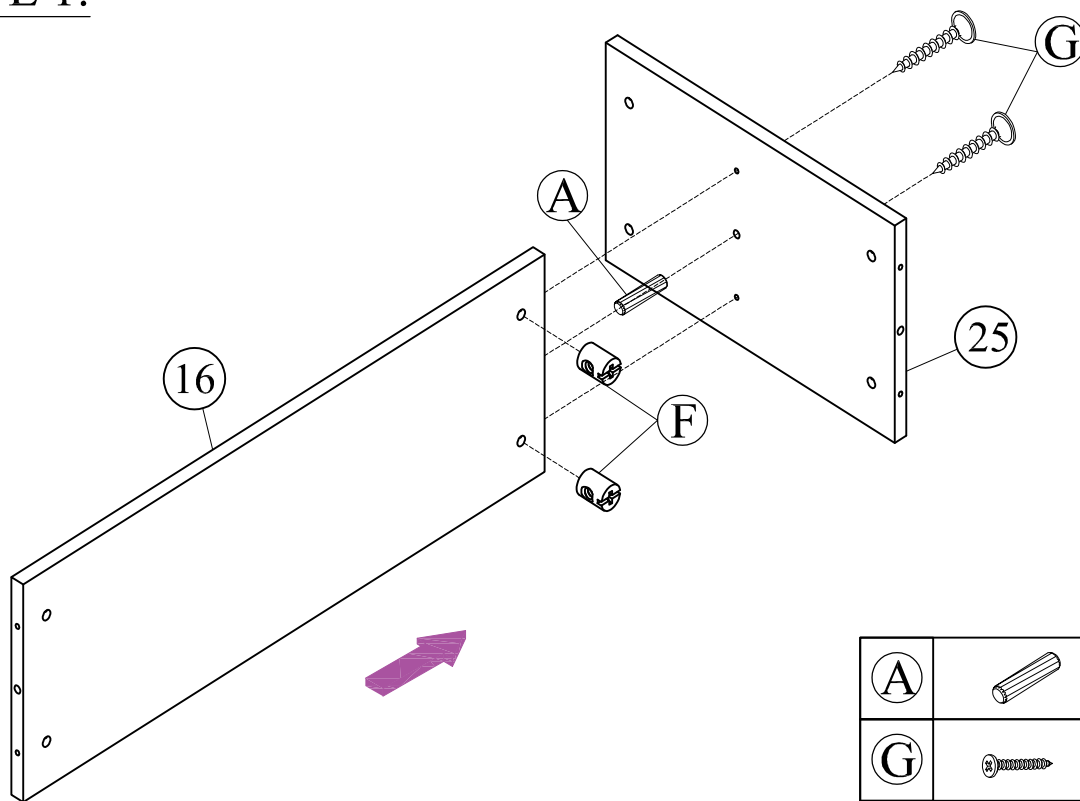

STEP 1:

ÉTAPE 1:





(A)		1pc 1pièce
(G)		2pcs 2pièces
(F)		2pcs 2pièces

STEP 2:

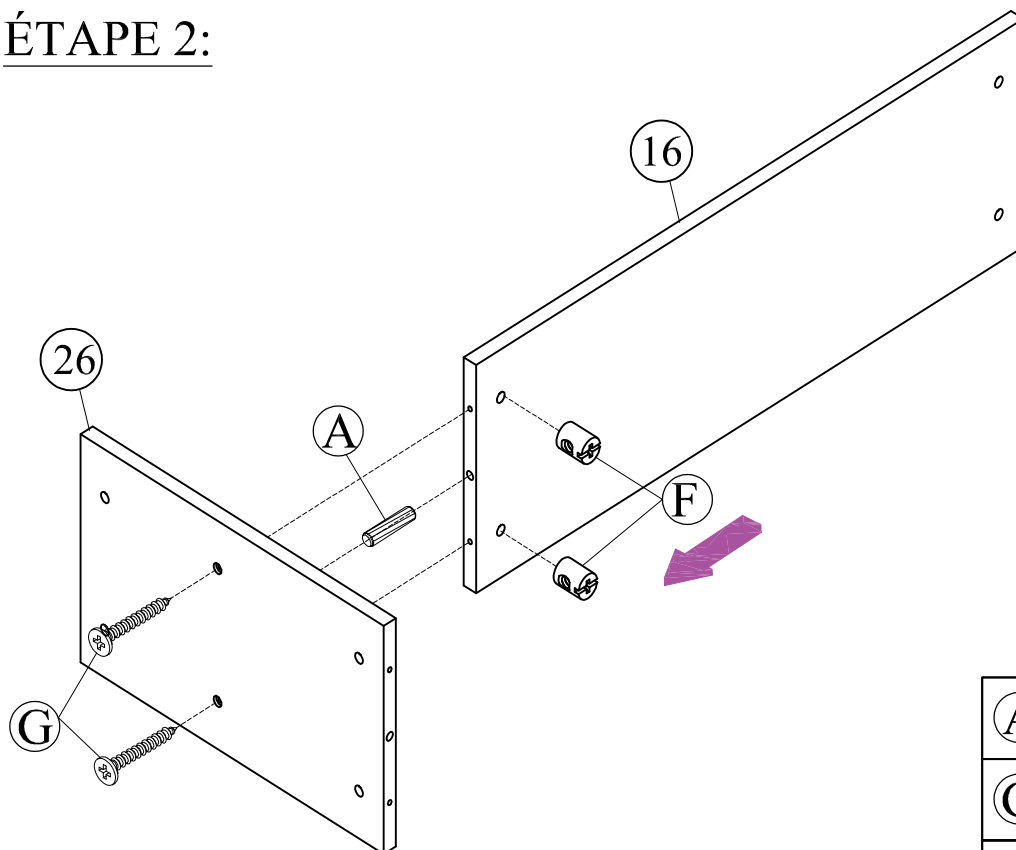
ÉTAPE 2:



(A)		1pc 1pièce
(G)		2pcs 2pièces
(F)		2pcs 2pièces

STEP 3:

ÉTAPE 3:

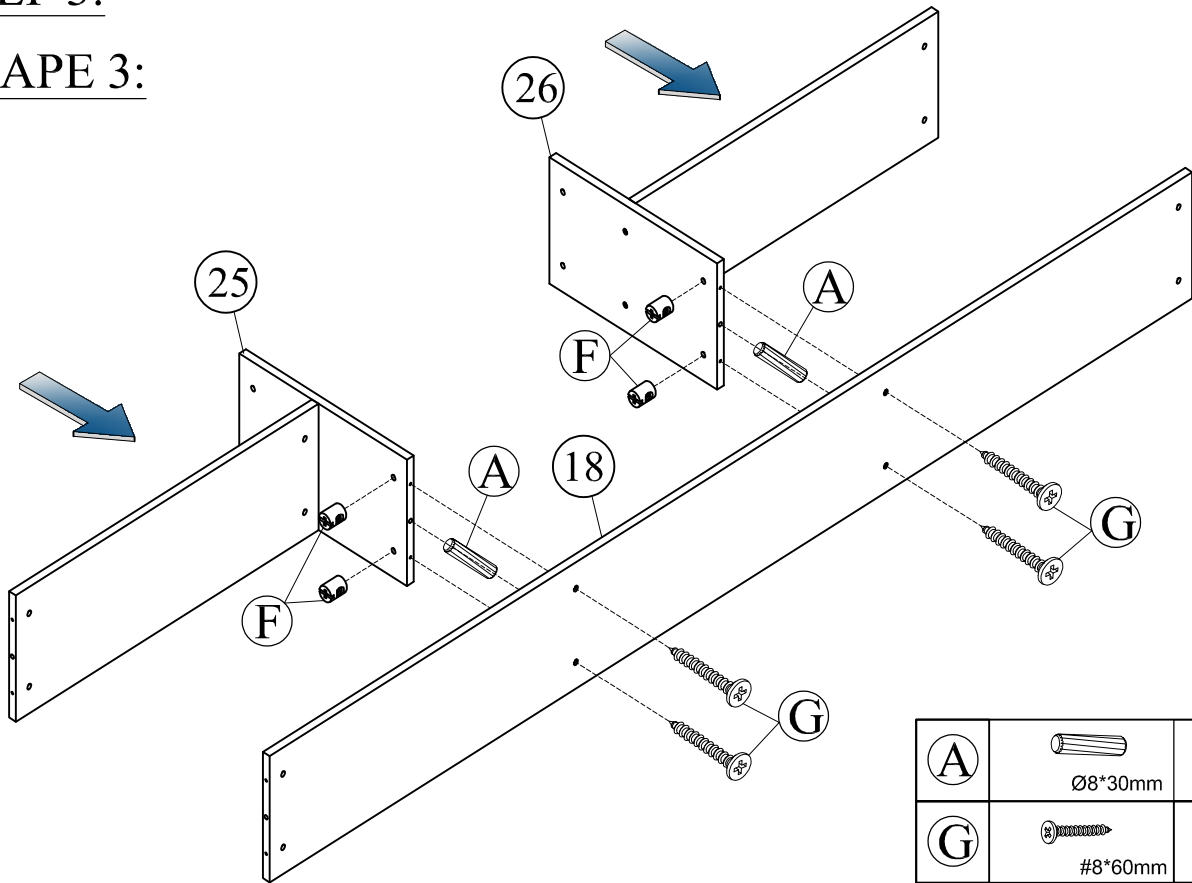

(A)	Ø8*30mm	2pcs 2pièces
(G)	#8*60mm	4pcs 4pièces
(F)	Ø10*10mm	4pcs 4pièces

STEP 4.1:

ÉTAPE 4.1:

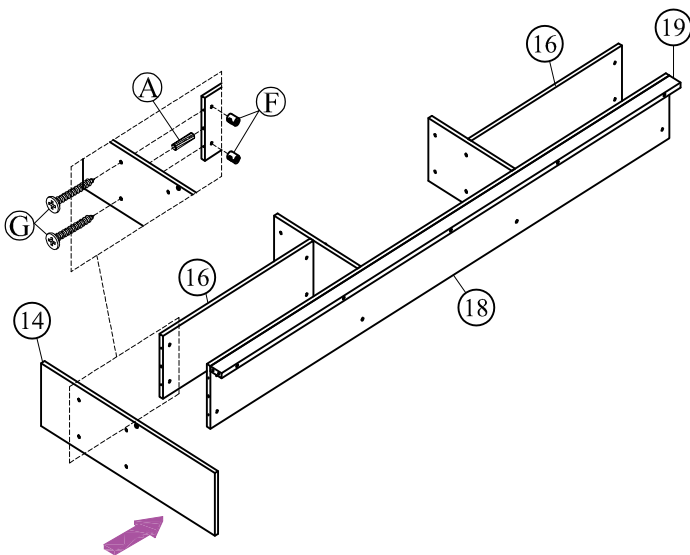

(A)	Ø8*30mm	1pc 1pièces
(G)	#8*60mm	2pcs 2pièces
(F)	Ø10*10mm	2pcs 2pièces

STEP 4.2:

ÉTAPE 4.2:

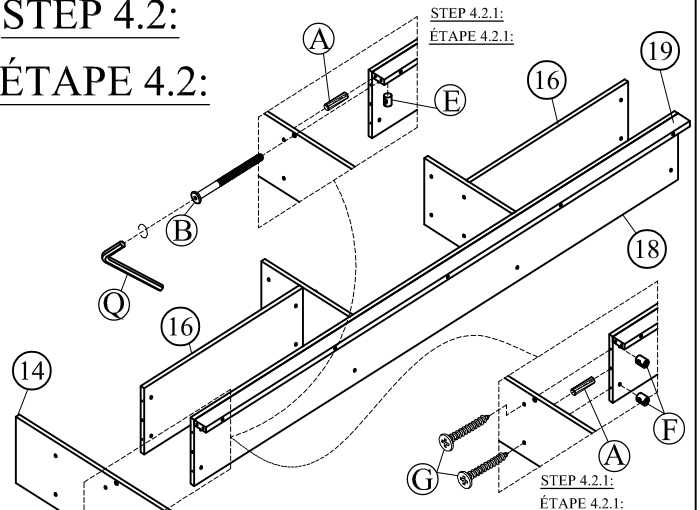



(G)	#8*60mm	2pcs 2pièces
(F)	Ø10*10mm	2pcs 2pièces
(A)	Ø8*30mm	2pcs 2pièces
(E)	M6*13mm	1pc 1pièce
(B)	M6*60mm	1pc 1pièce
(Q)	1pc 1pièce	

STEP 5.1:

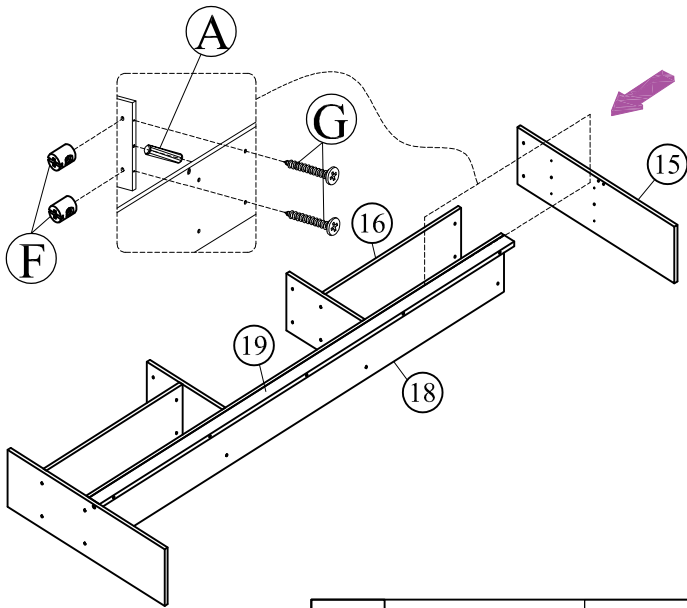

ÉTAPE 5.1:







(A)	 Ø8*30mm	1pc 1pièce
(G)	 #8*60mm	2pcs 2pièces
(F)	 Ø10*10mm	2pcs 2pièces

STEP 5.2:

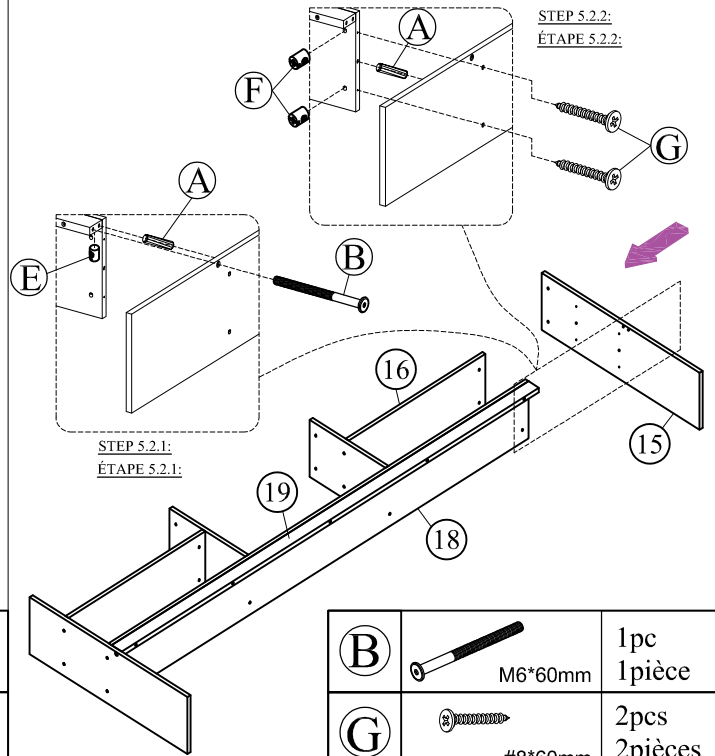
ÉTAPE 5.2:

(E)	 M6*13mm	1pc 1pièce
(A)	 Ø8*30mm	2pcs 2pièces



(B)	 M6*60mm	1pc 1pièce
(G)	 #8*60mm	2pcs 2pièces
(F)	 Ø10*10mm	2pcs 2pièces

STEP 6:

ÉTAPE 6:

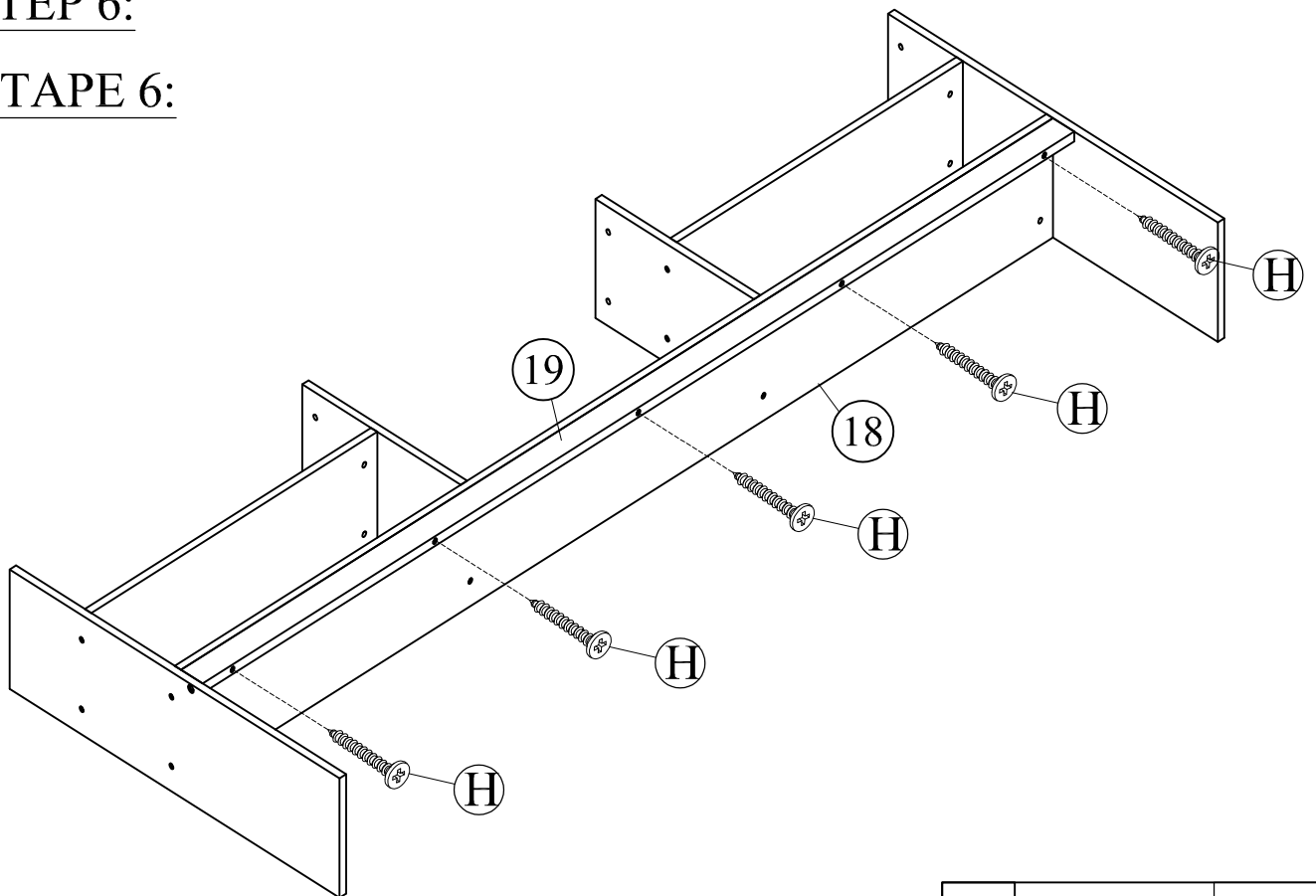

(H)	 #8*50mm	5pcs 5pièces
-----	---	-----------------

STEP 7:

ÉTAPE 7:

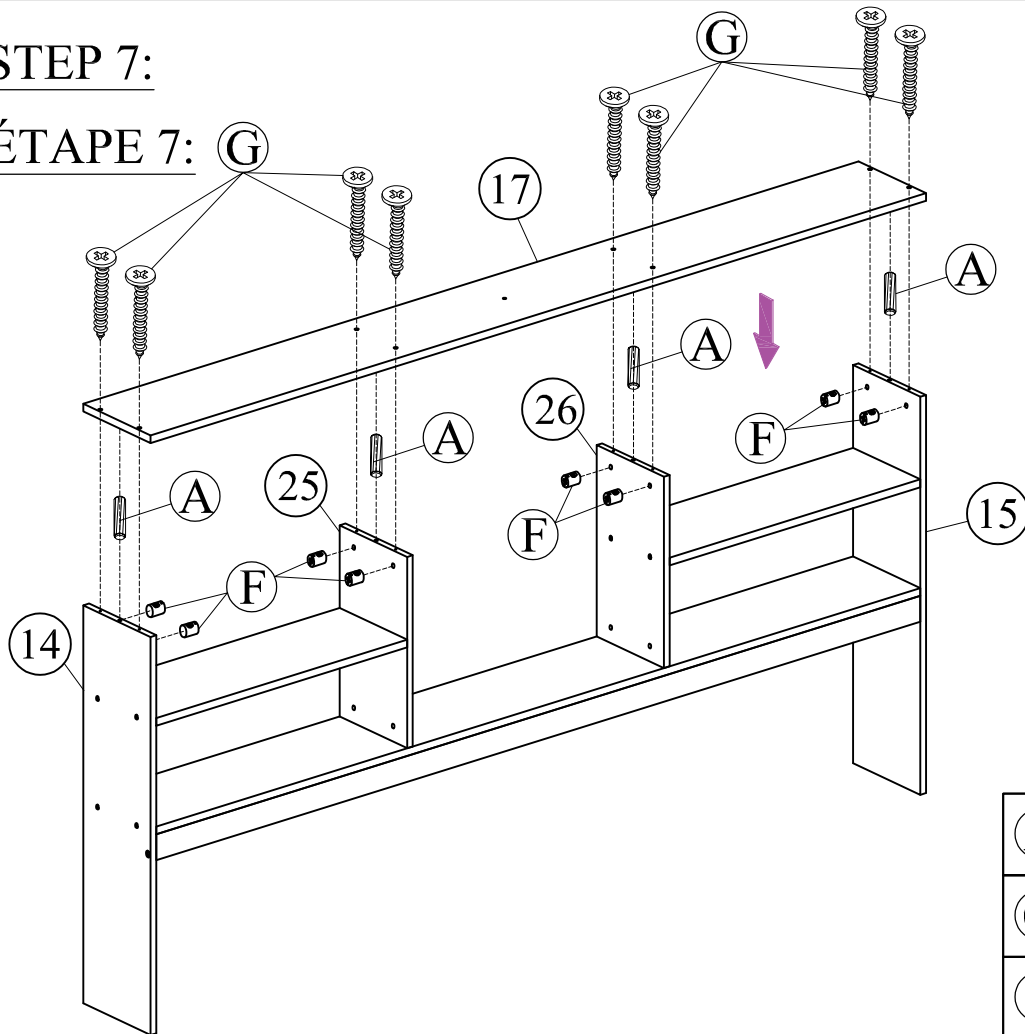

(A)		4pcs 4pièces
(G)		8pcs 8pièces
(F)		8pcs 8pièces

STEP 8:

ÉTAPE 8:

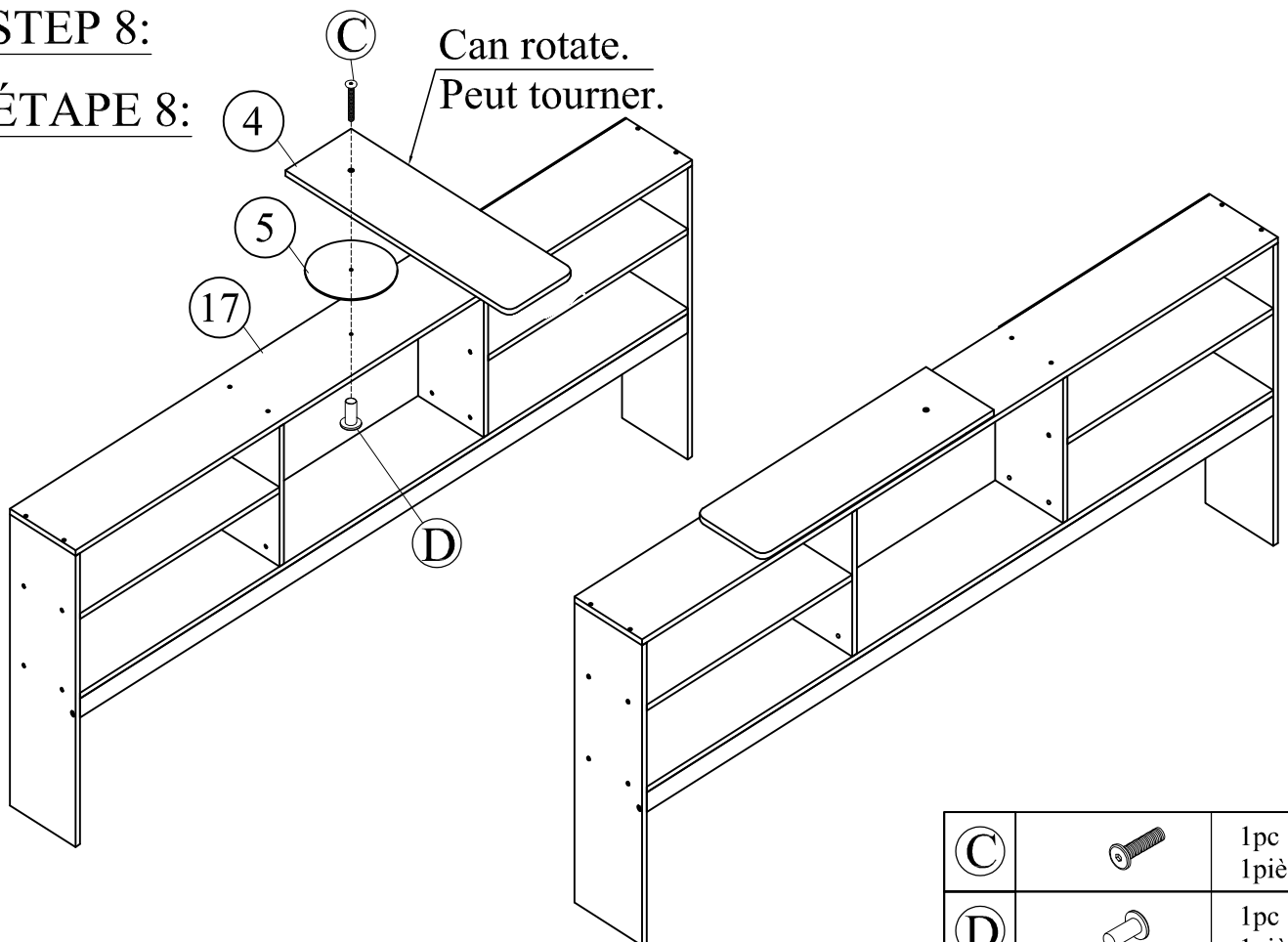

(C)		1pc 1pièce
(D)		1pc 1pièce

STEP 9:

ÉTAPE 9:

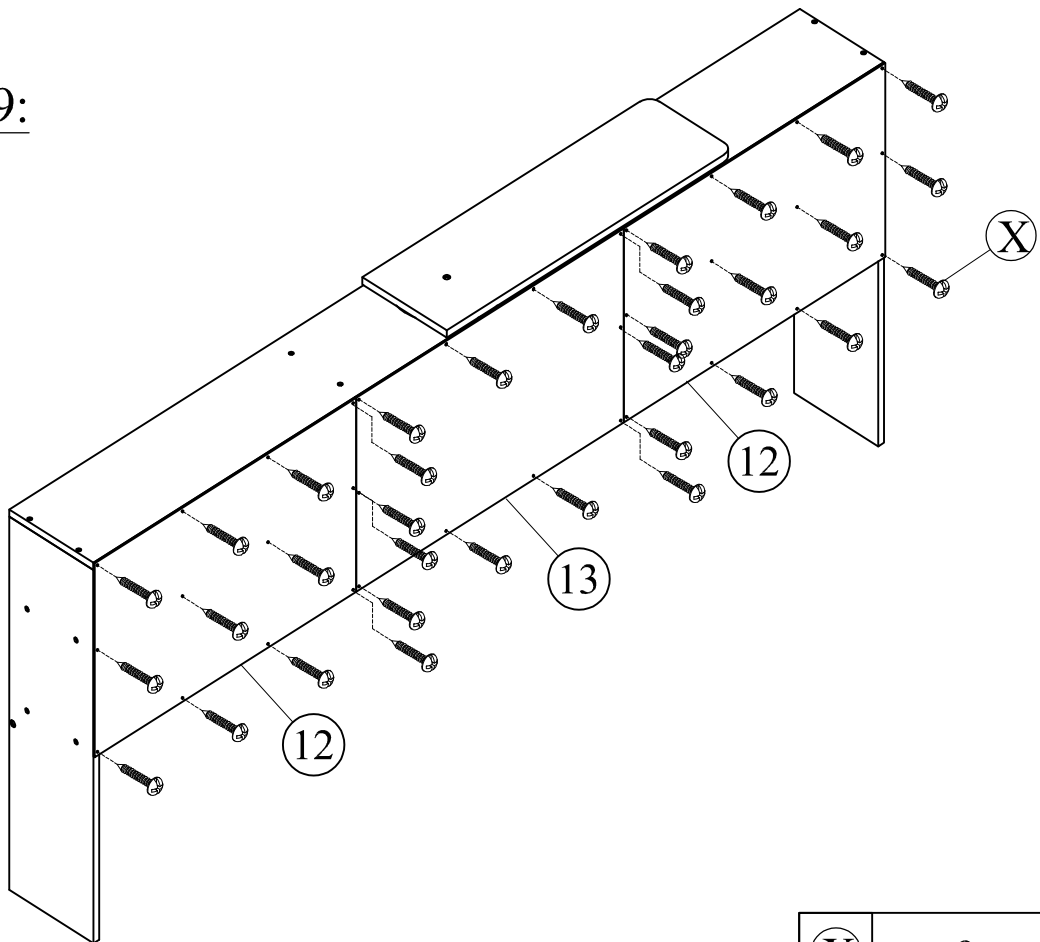



(X)		34pcs 34pièces
-----	---	-------------------

STEP 10:

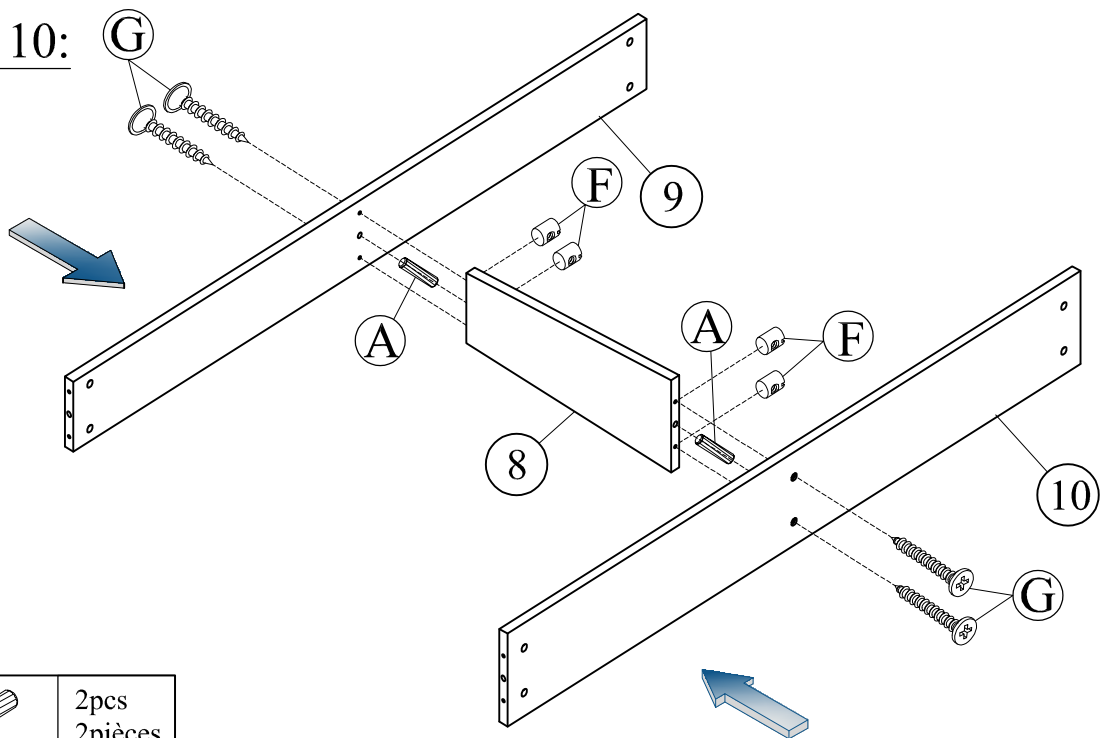

ÉTAPE 10:

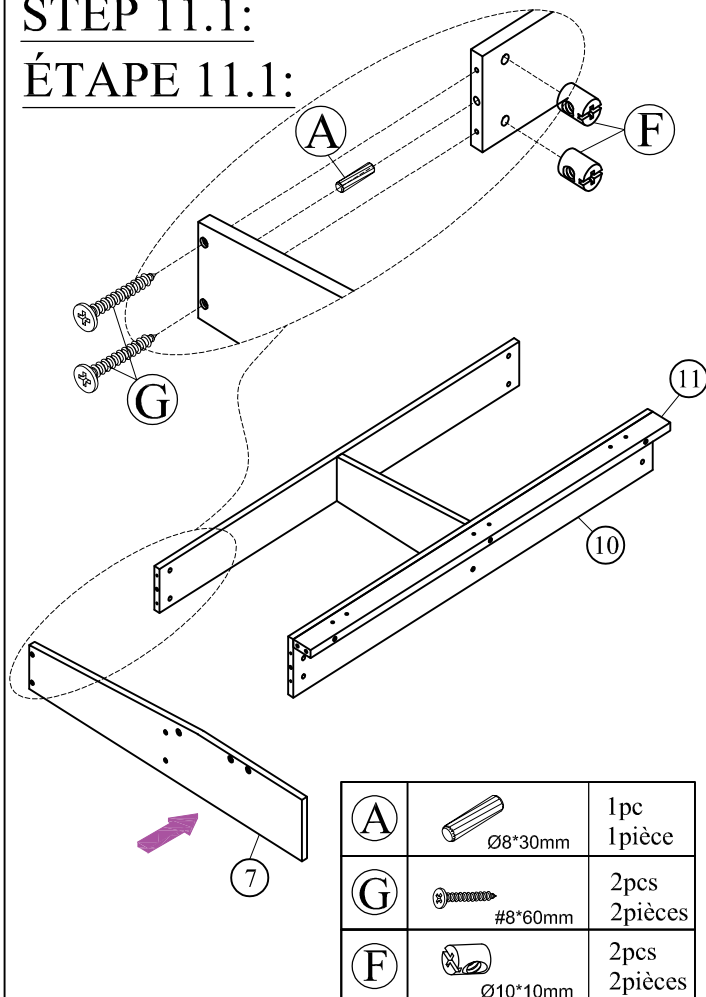

(A)		2pcs 2pièces
(G)		4pcs 4pièces
(F)		4pcs 4pièces

STEP 11.1:
ÉTAPE 11.1:







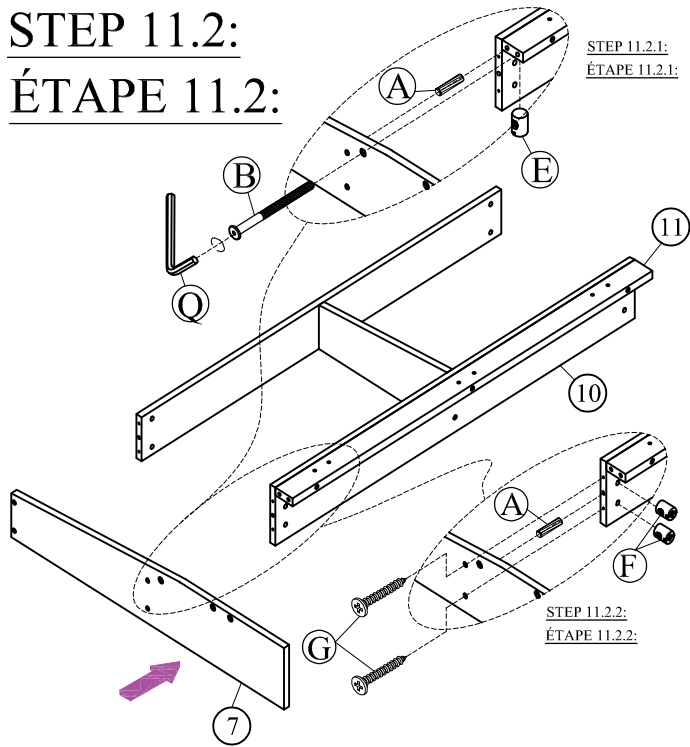

A	 Ø8*30mm	1pc 1pièce
G	 #8*60mm	2pcs 2pièces
F	 Ø10*10mm	2pcs 2pièces

STEP 11.2:
ÉTAPE 11.2:





STEP 11.2.1:
ÉTAPE 11.2.1:

STEP 11.2.2:
ÉTAPE 11.2.2:

Q	 1pc 1pièce	A	 Ø8*30mm	2pcs 2pièces
E	 M6*13mm	G	 #8*60mm	2pcs 2pièces
B	 M6*60mm	F	 Ø10*10mm	2pcs 2pièces

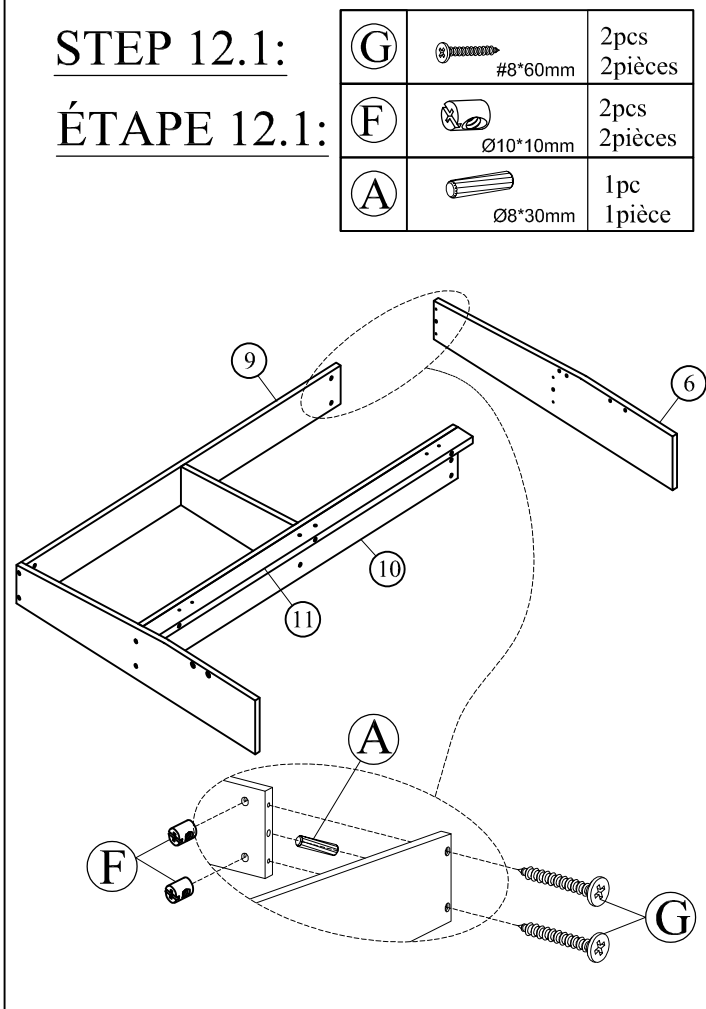
STEP 12.1:
ÉTAPE 12.1:





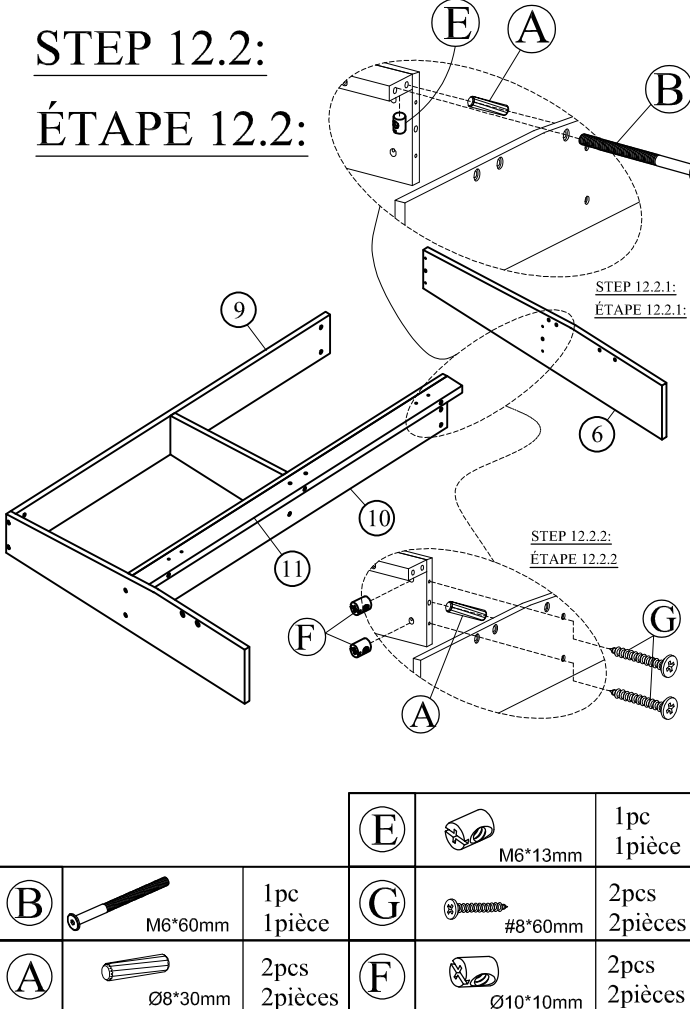

G	 #8*60mm	2pcs 2pièces
F	 Ø10*10mm	2pcs 2pièces
A	 Ø8*30mm	1pc 1pièce

STEP 12.2:
ÉTAPE 12.2:



STEP 12.2.1:
ÉTAPE 12.2.1:

STEP 12.2.2:
ÉTAPE 12.2.2:

E	 M6*13mm	1pc 1pièce
B	 M6*60mm	1pc 1pièce
A	 Ø8*30mm	2pcs 2pièces
G	 #8*60mm	2pcs 2pièces
F	 Ø10*10mm	2pcs 2pièces

STEP 13:

ÉTAPE 13:

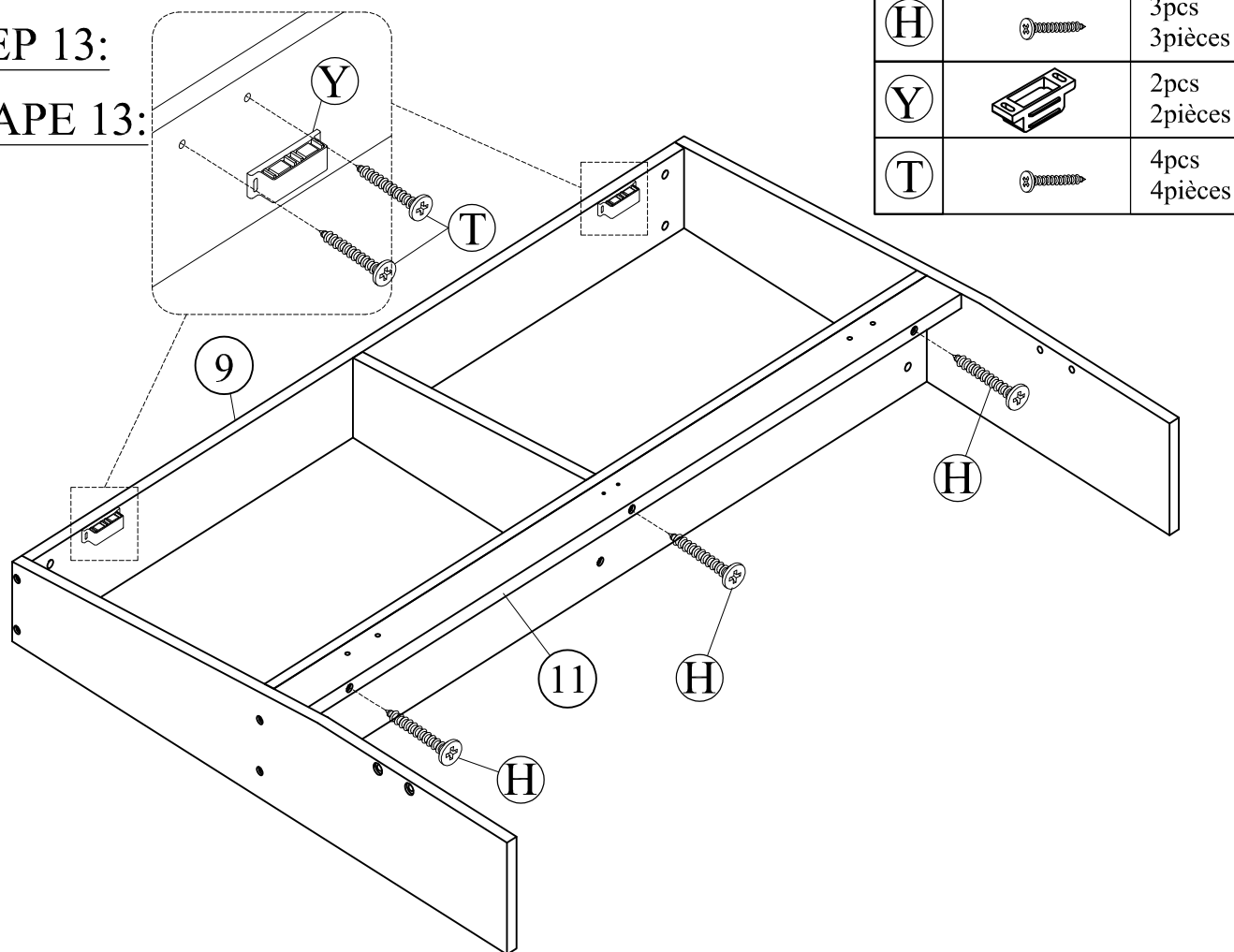

(H)		3pcs 3pièces
(Y)		2pcs 2pièces
(T)		4pcs 4pièces

STEP 14:

ÉTAPE 14:

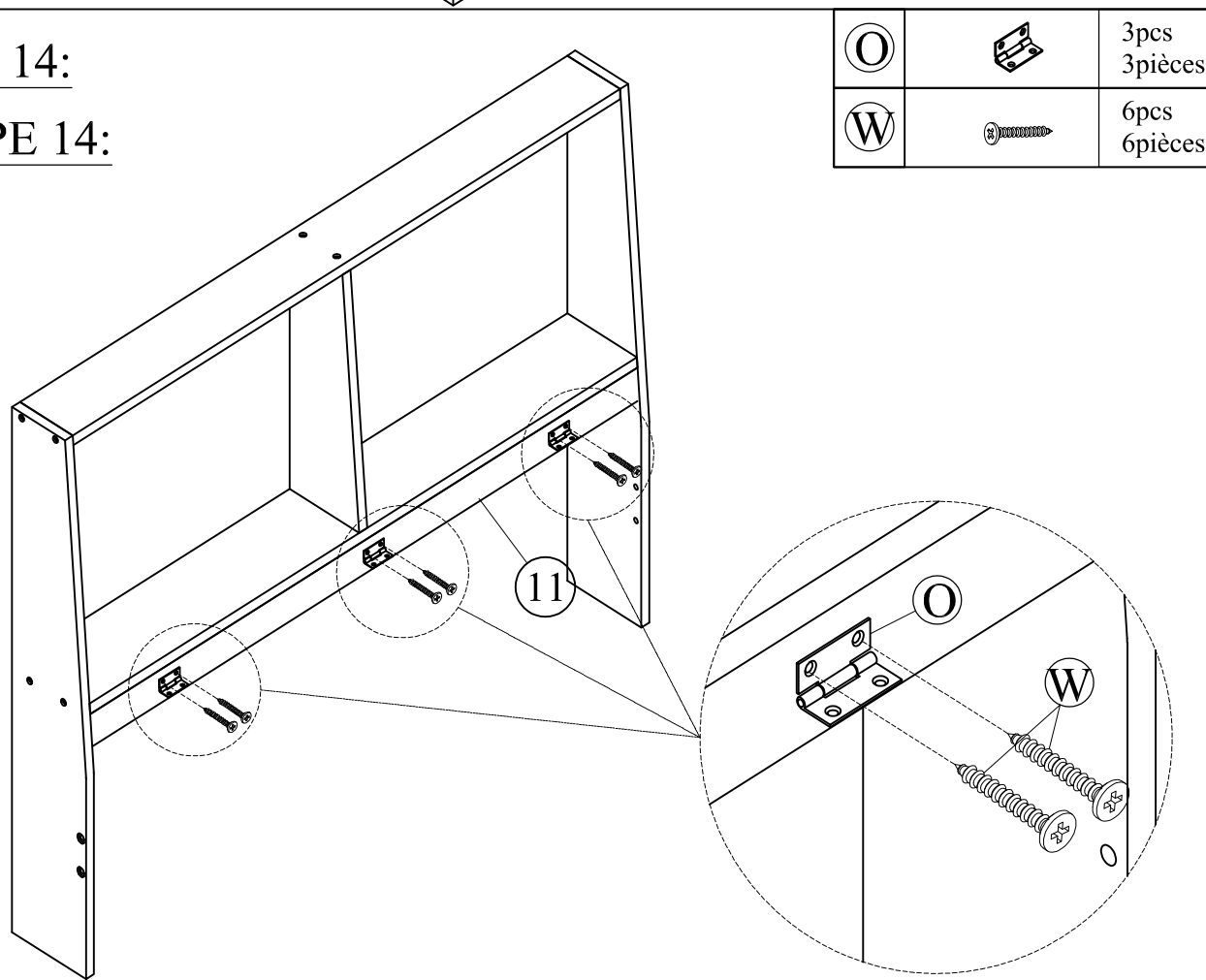

(O)		3pcs 3pièces
(W)		6pcs 6pièces

STEP 15:

ÉTAPE 15:

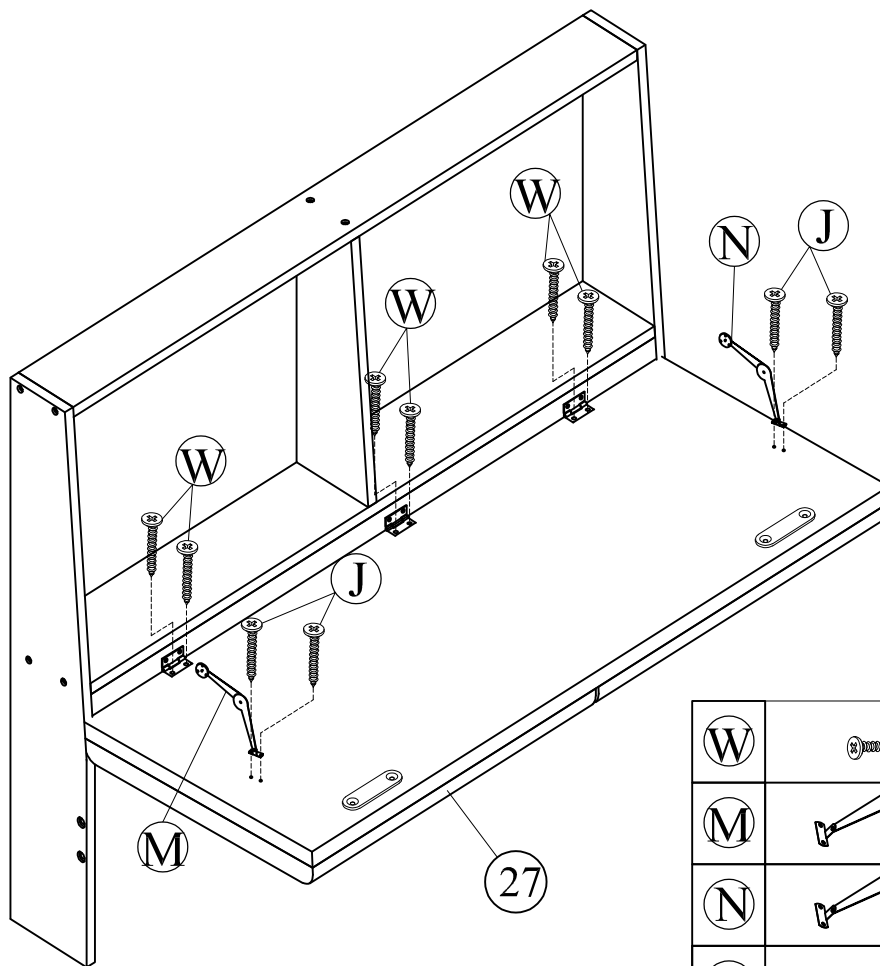

W		6pcs 6pièces
M		1pc 1pièce
N		1pc 1pièce
J		4pcs 4pièces

STEP 16:

ÉTAPE 16:

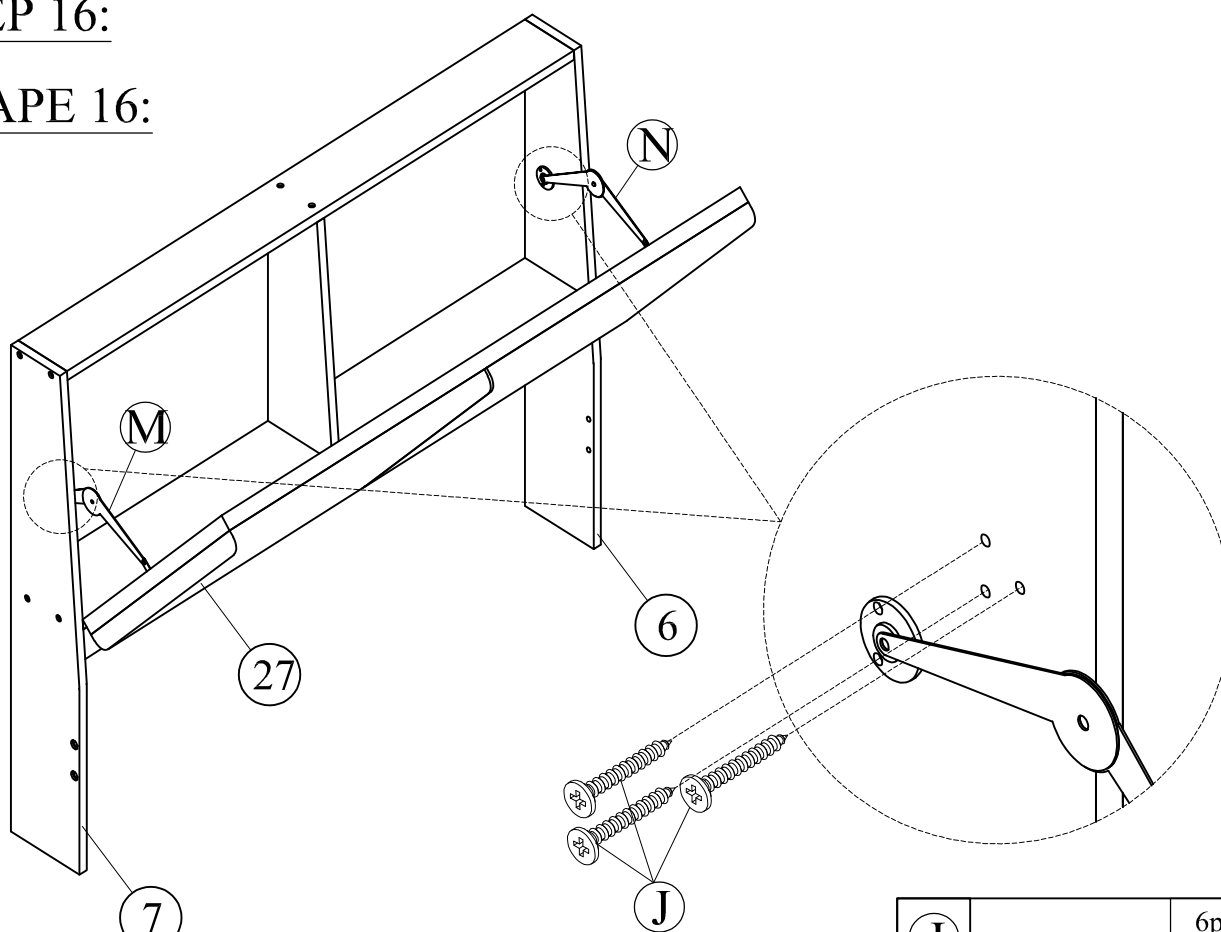

J		6pcs 6pièces
---	--	-----------------

STEP 17:

ÉTAPE 17:

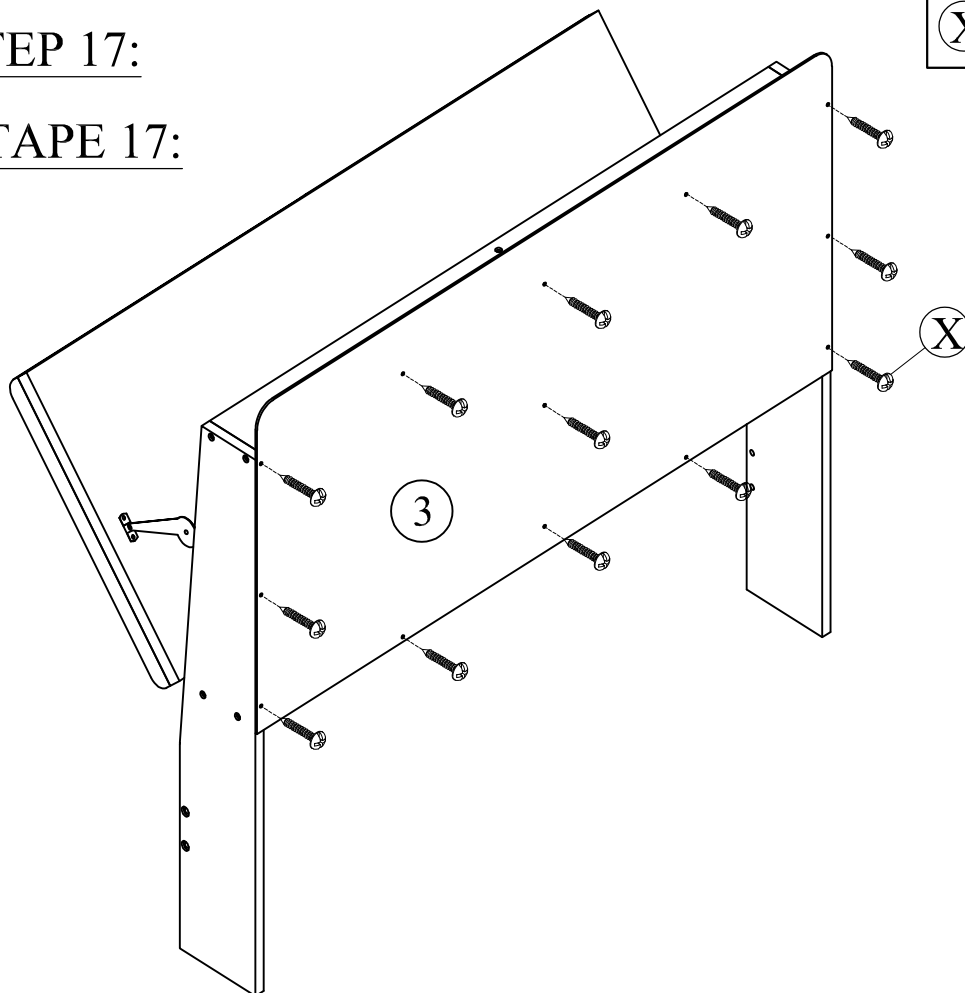





(X)		13pcs 13pièces
-----	---	-------------------

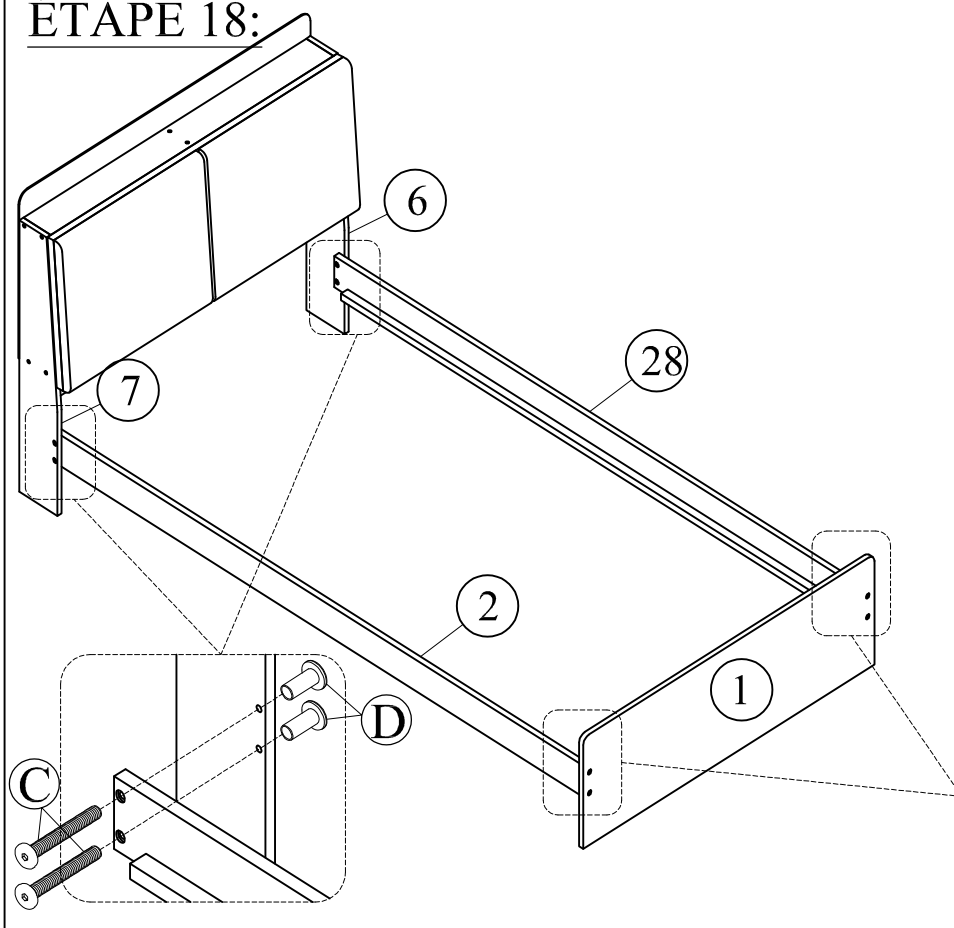

STEP 18:

ÉTAPE 18:



(C)		4pcs 4pièces
(D)		4pcs 4pièces
(E)		4pcs 4pièces
(B)		4pcs 4pièces
(A)		2pcs 2pièces

STEP 19:
ÉTAPE 19:

I		20pcs 20pièces
Z		4pcs 4pièces
Q		1pc 1pièce

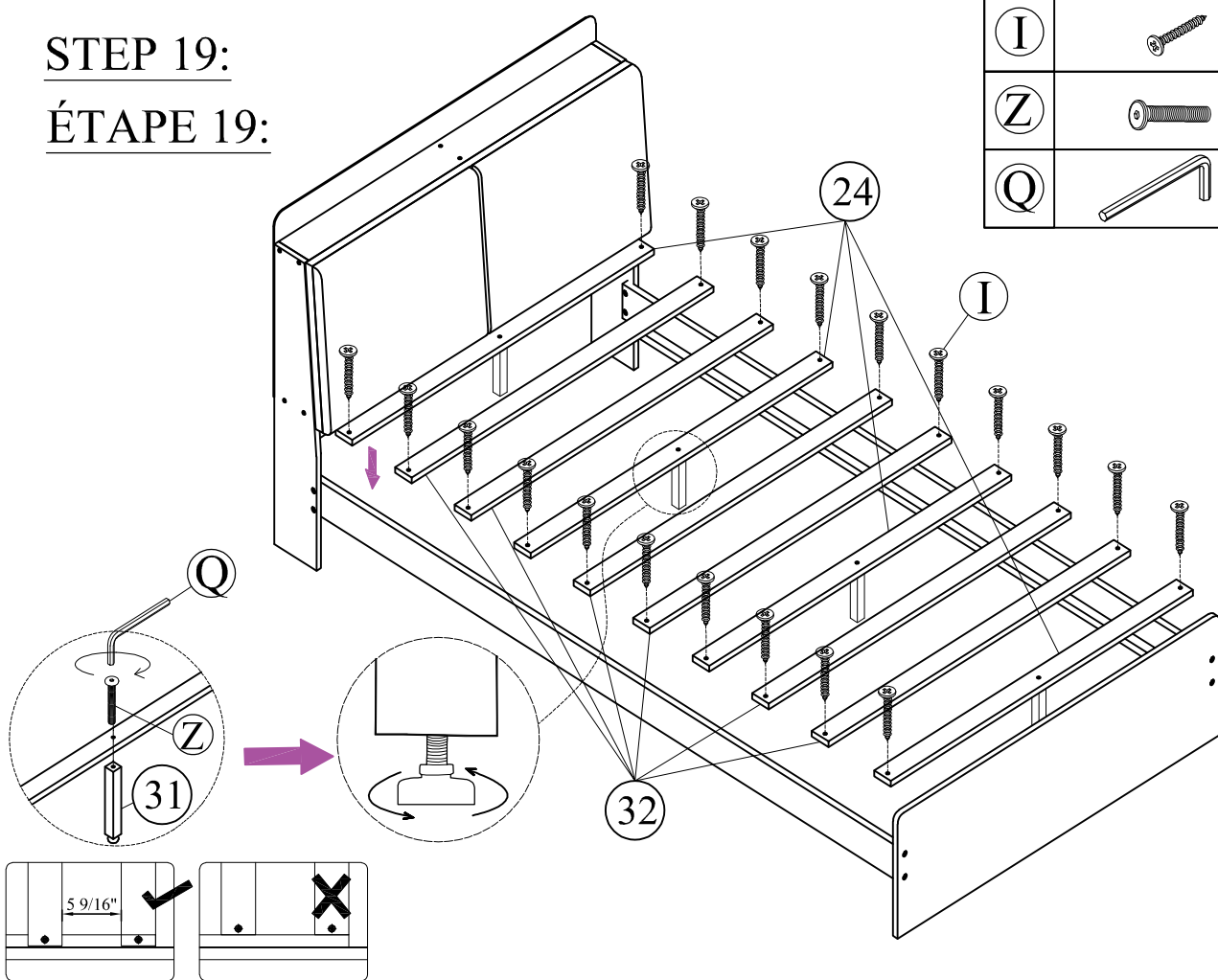

STEP 20:
ÉTAPE 20:

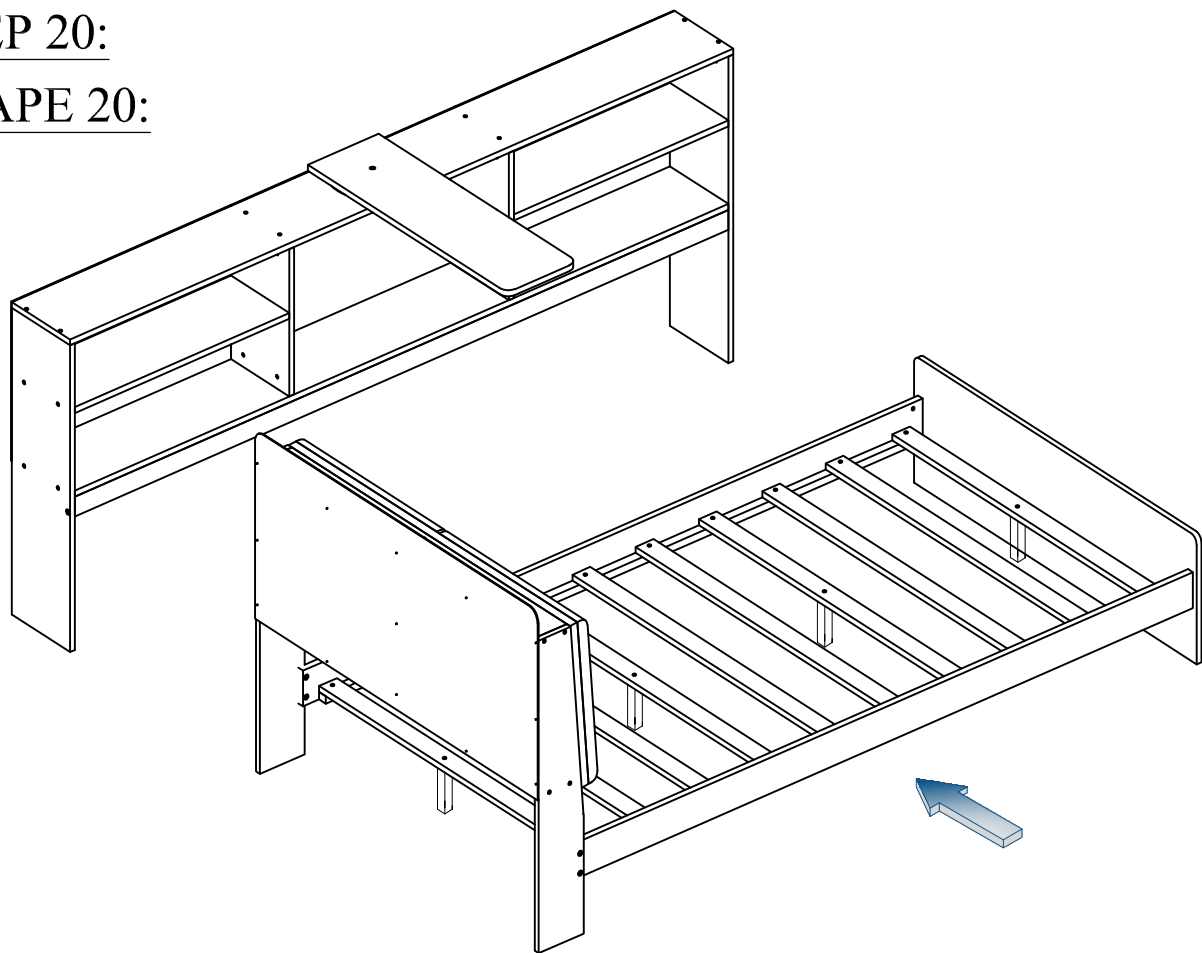

STEP 21:

ÉTAPE 21:

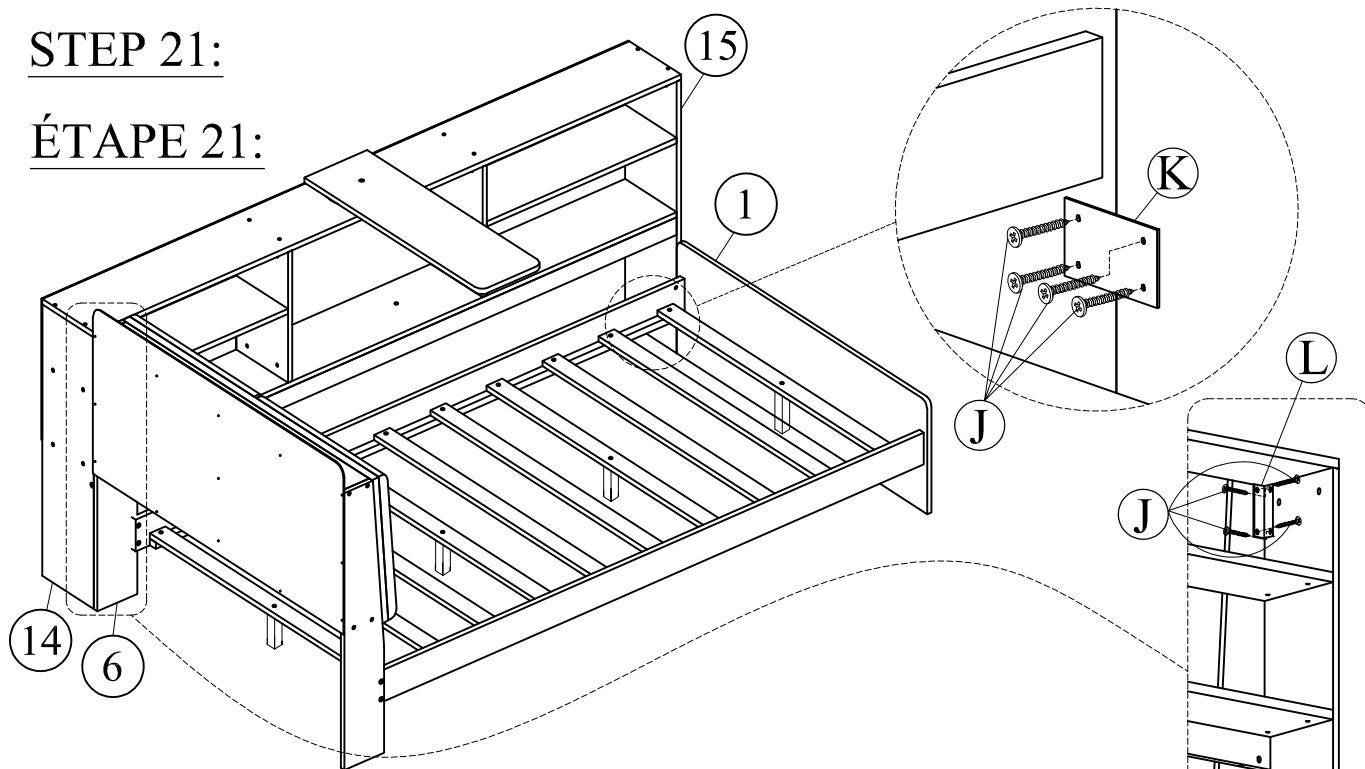

(K)		1pc 1pièce
(J)		12pcs 12pièces
(L)		2pcs 2pièces

(S)		8pcs 8pièces
-----	--	-----------------

STEP 22:

ÉTAPE 22:

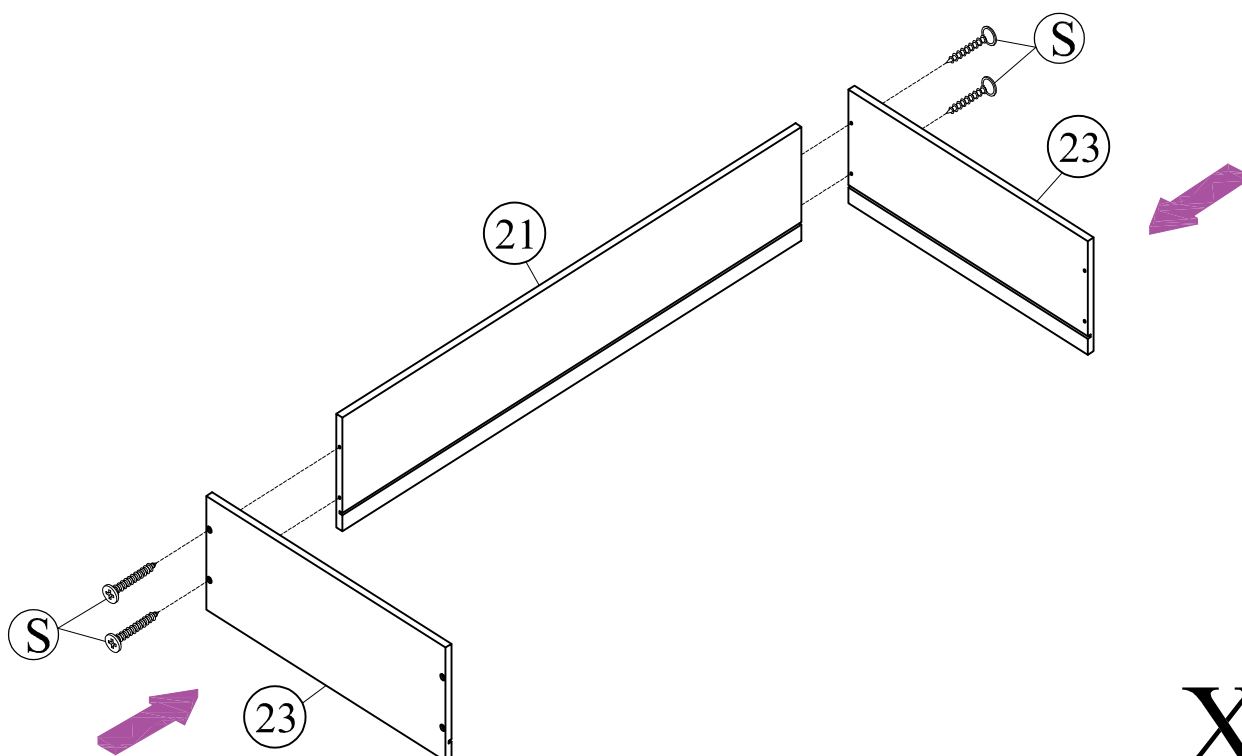

X2

STEP 23:

ÉTAPE 23:

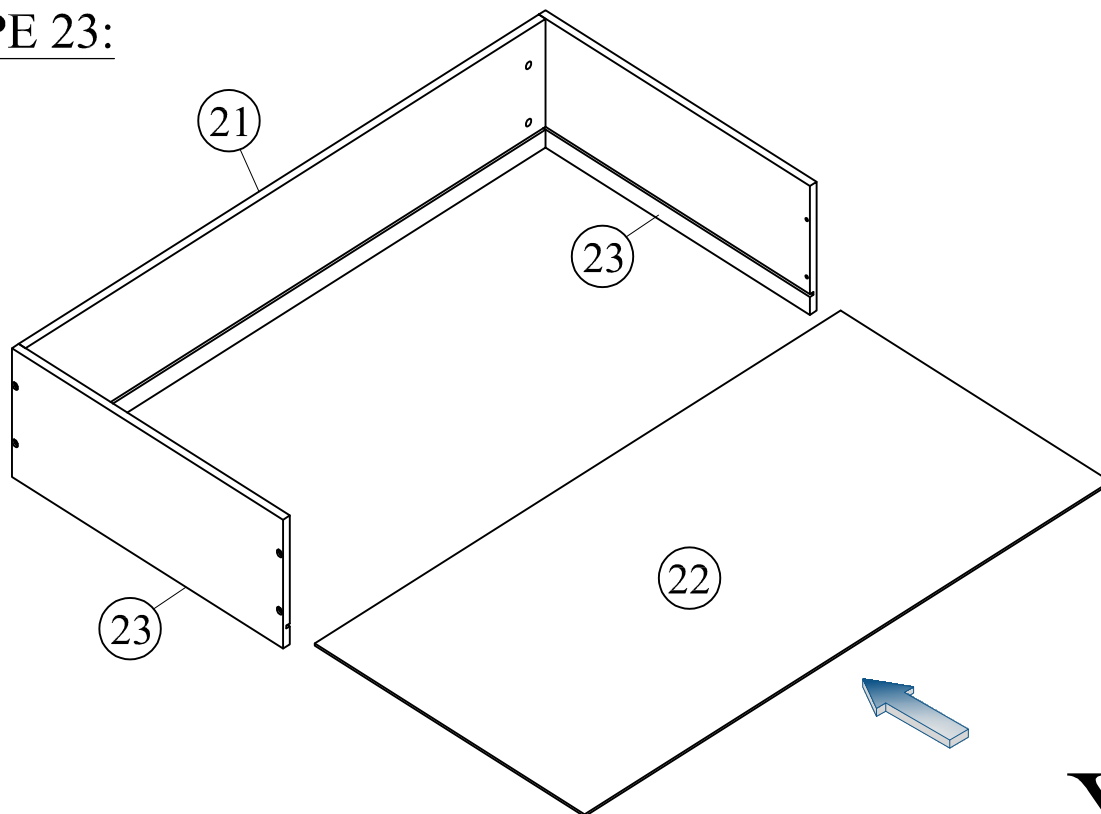

X2

STEP 24:

ÉTAPE 24:

S		8pcs 8pièces
----------	---	-----------------

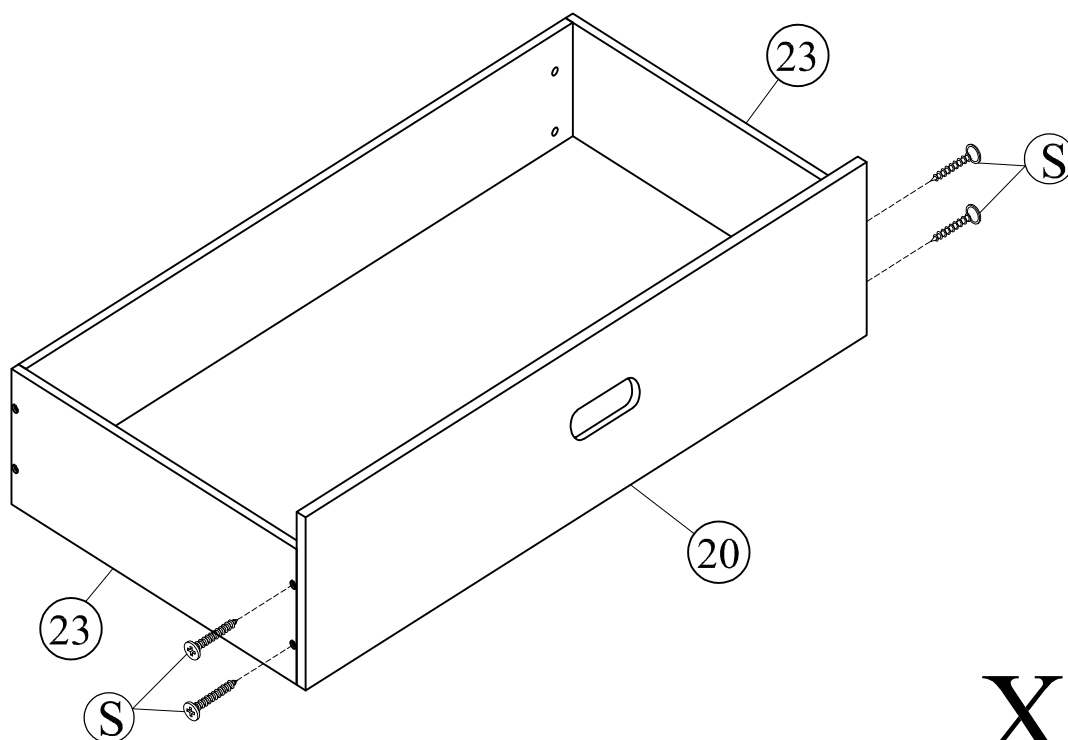

X2

STEP 25:

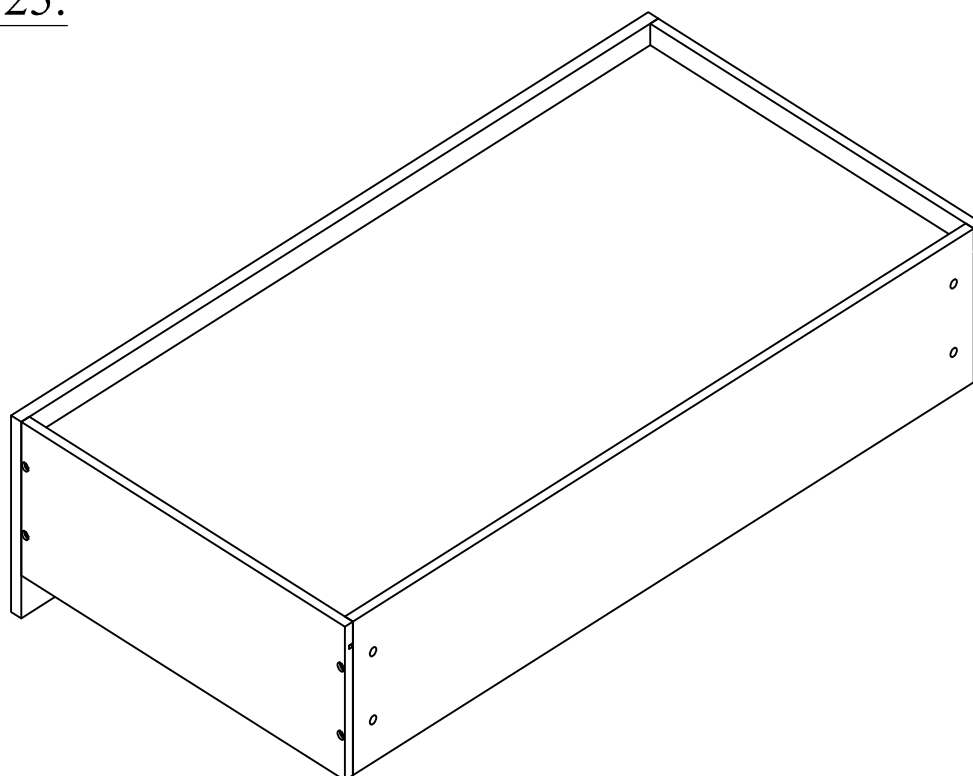

ÉTAPE 25:



X2

STEP 26:

ÉTAPE 26:

I		16pcs 16pièces
P		8pcs 8pièces

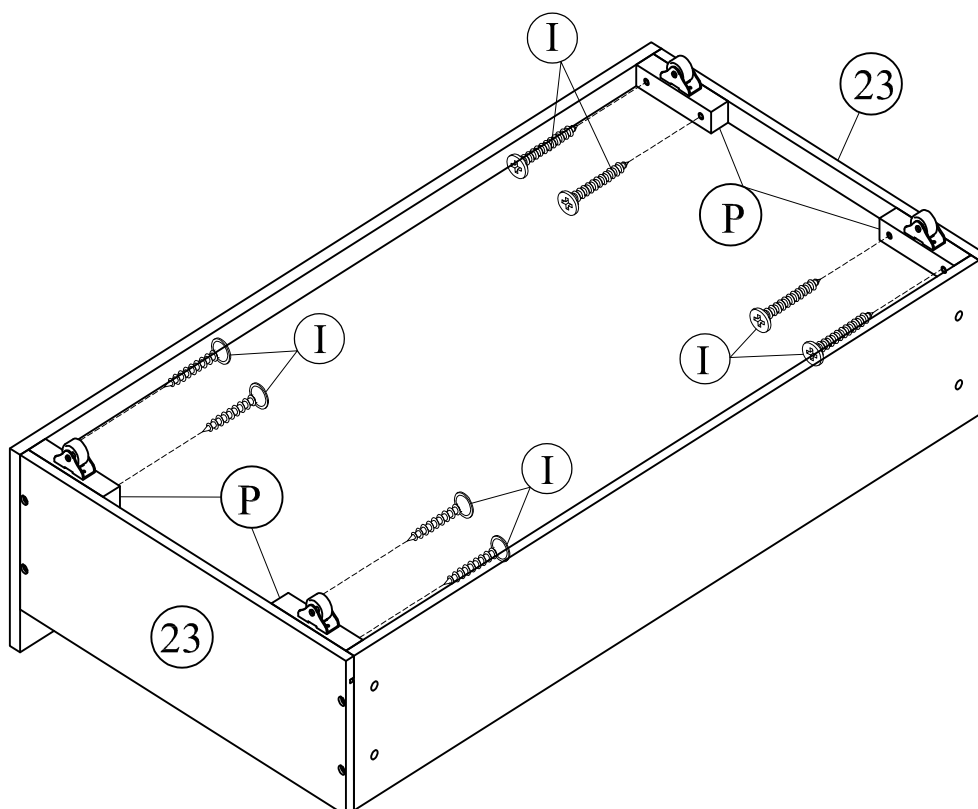

X2

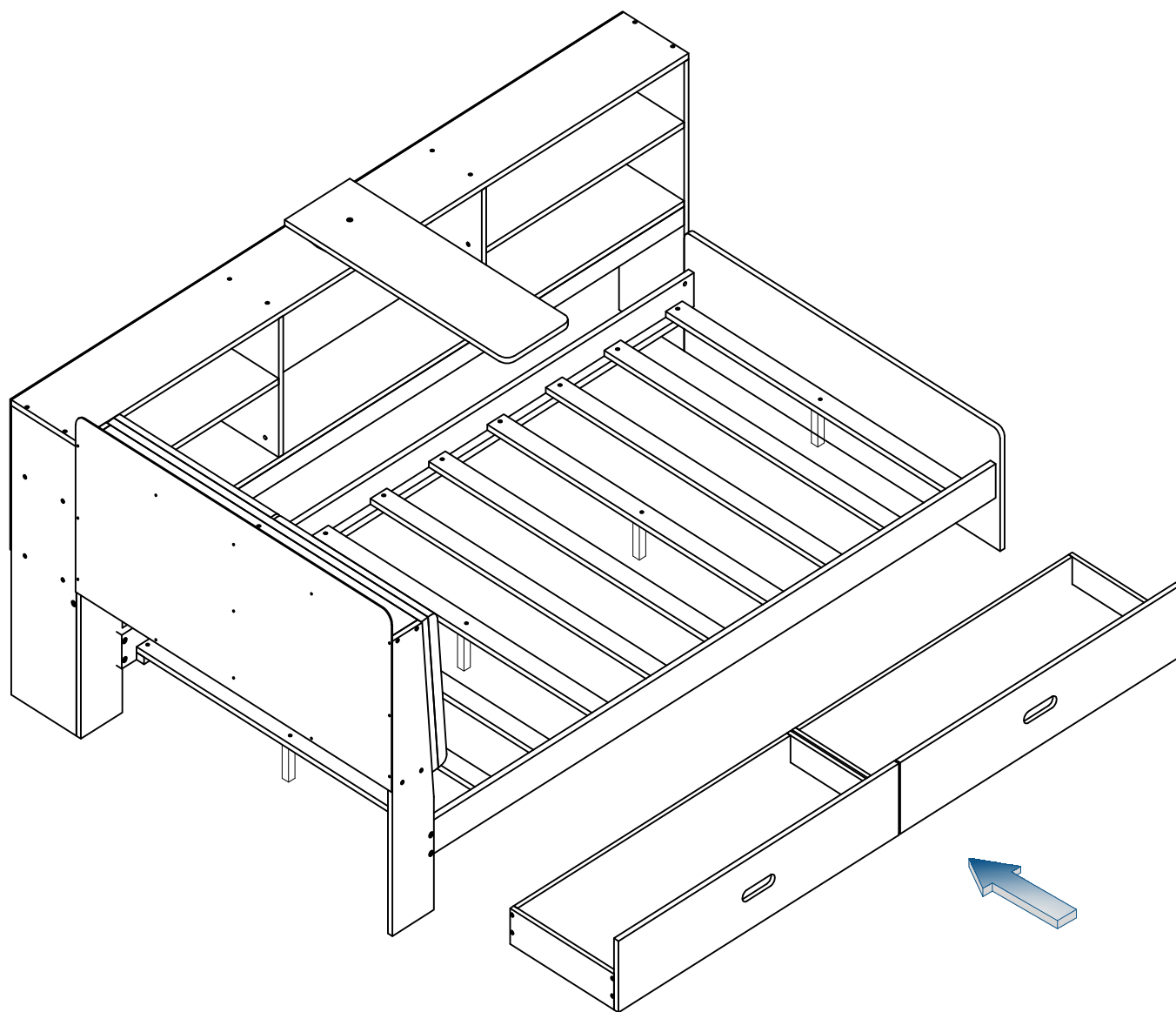

STEP 27:

ÉTAPE 27:



STEP 28:

ÉTAPE 28:

Z		2pcs 2pièces
I		4pcs 4pièces

STEP 28.1
ÉTAPE 28.1

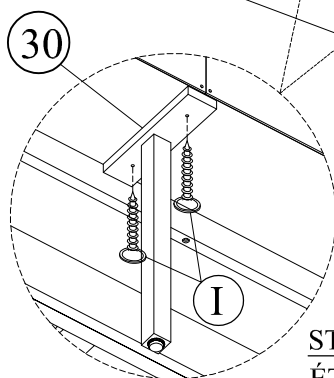
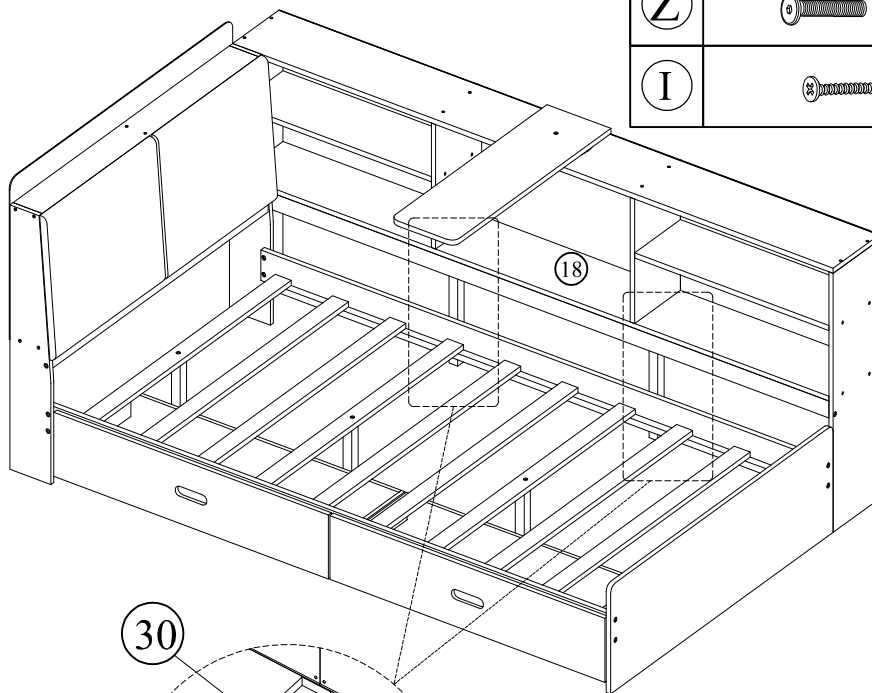
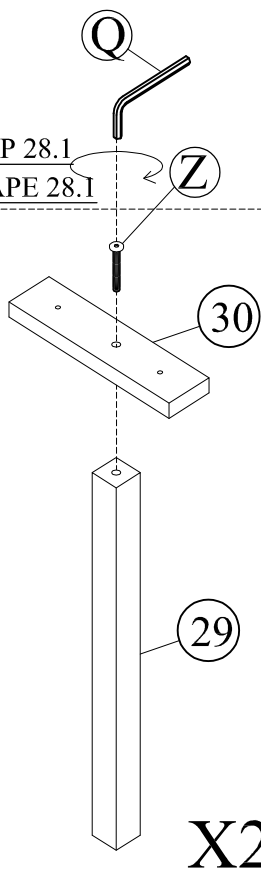

STEP 28.2
ÉTAPE 28.2

Q		1pc 1pièce
----------	---	---------------

FINAL:

FINALE:

