

# Vintage Folding Adirondack Chair

## Assembly Instructions



**Important** - Please read these instructions fully before starting assembly

**HASSLE-FREE WARRANTY**  
We stand behind the quality of our products.  
For full warranty policy, email us.

350 LBS  
CAPACITY

1 PERSON  
ASSEMBLY

AROUND 20 MIN.  
ASSEMBLY

## Components

Please check you have all the components listed below.

Note: The illustration of the product shows the exact position of each part. Check when assembling.

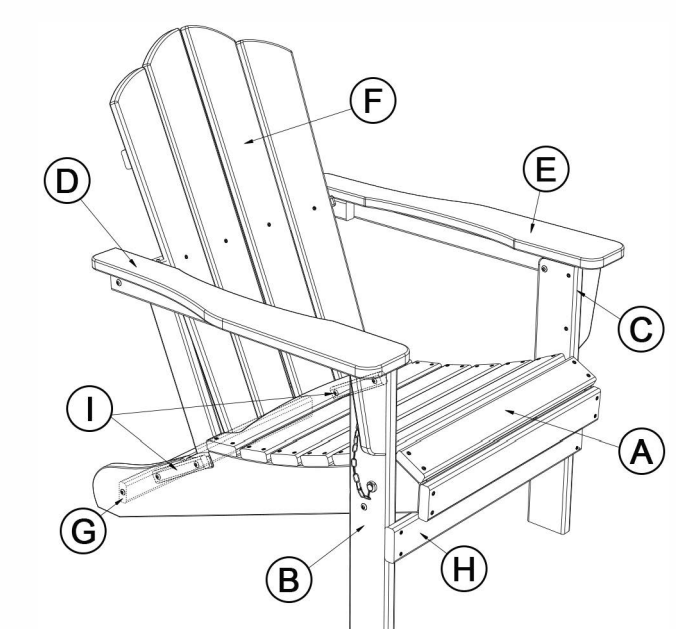

#	Description	Qty.
A	Seat Frame	1
B	Right Leg	1
C	Left Leg	1
D	Right Arm	1
E	Left Arm	1
F	Backrest	1
G	Back Stretcher	1
H	Front Stretcher	1
I	Braces	2

## Hardware & Tools

Note: The quantities below are the correct amount to complete the assembly. In some cases more fittings may be supplied than required.

① x 4

M6x40 Screws

② x 4

M6x40MM Bolt

③ x 2

M6 x 50MM Bolts

④ x 4

M6 x 60MM Bolts

⑤ x 2

M6x70MM Bolts

⑥ x 6

Washer

⑦ x 6

Nut

Hex Key (Included)

Wrench (Included)

## Assembly Instructions

**⚠ Caution:** Please do not over-tighten bolts and screws during assembly.

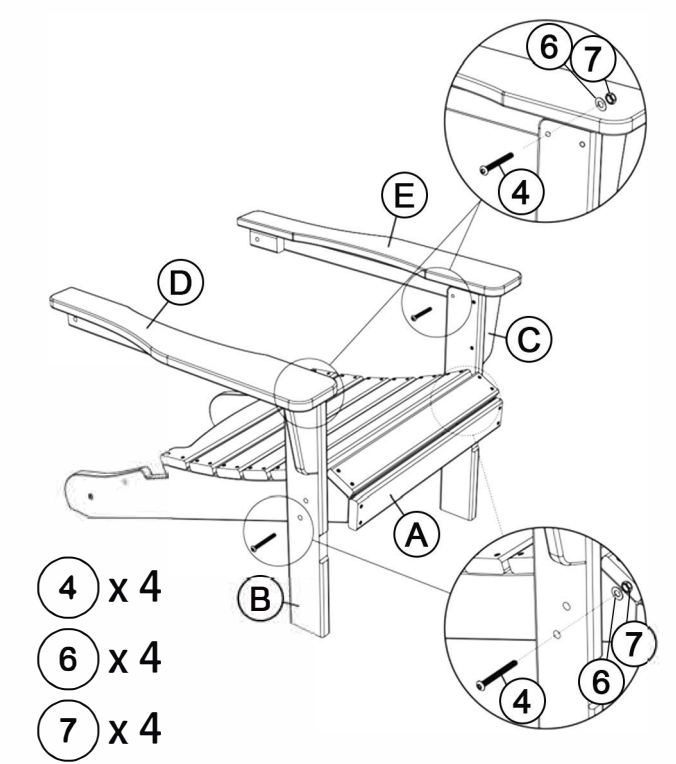

- STEP 1**
- Attach "Chair Legs (B/C)" to "Chair Seat Frame (A)" - Using "④ M6 x 60MM Bolts & ⑥ washer ⑦ Nut", tighten with hex key and wrench.
  - Attach "Chair Arms (D/E)" to "Chair Legs (B/C)" - Using "④ M6 x 60MM Bolts & ⑥ washer ⑦ Nut", tighten with hex key and wrench.

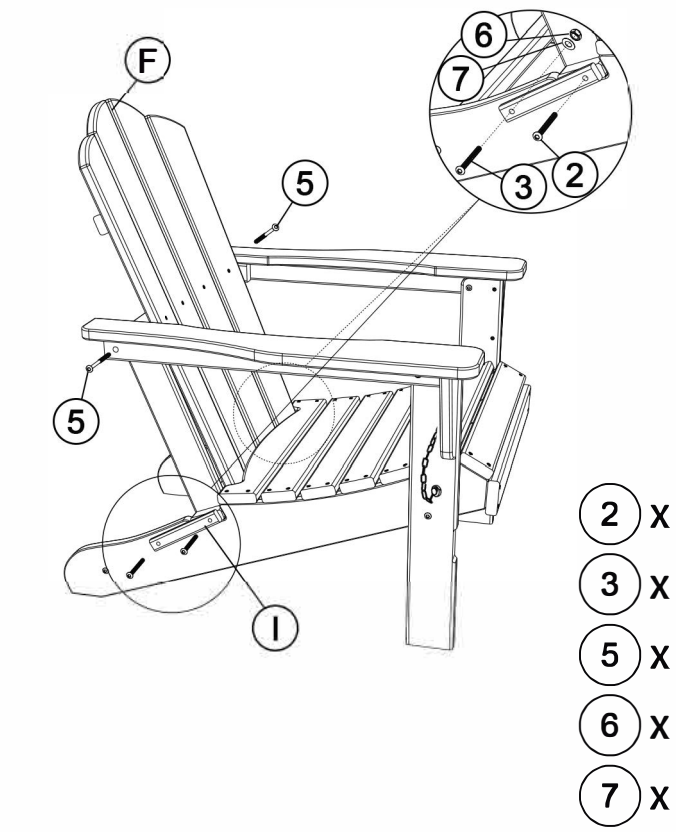

- STEP 2**
- Attach "Chair Back (F)" to "Chair Arms (D/E)" - Using "⑤ M6 x 70MM Bolts", tighten with screwdriver.
  - Connect "Chair Back (F)" to "Chair Seat Frame (A)" with "Braces (I)" - Using "② M6 x 40MM Bolts and ③ M6 x 50MM Bolts & ⑥ Washer & ⑦ Nut", tighten with hex key and wrench.

- ② x 2
- ③ x 2
- ⑤ x 2
- ⑥ x 2
- ⑦ x 2

## Assembly Instructions

**⚠ Caution:** Please do not over-tighten bolts and screws during assembly.

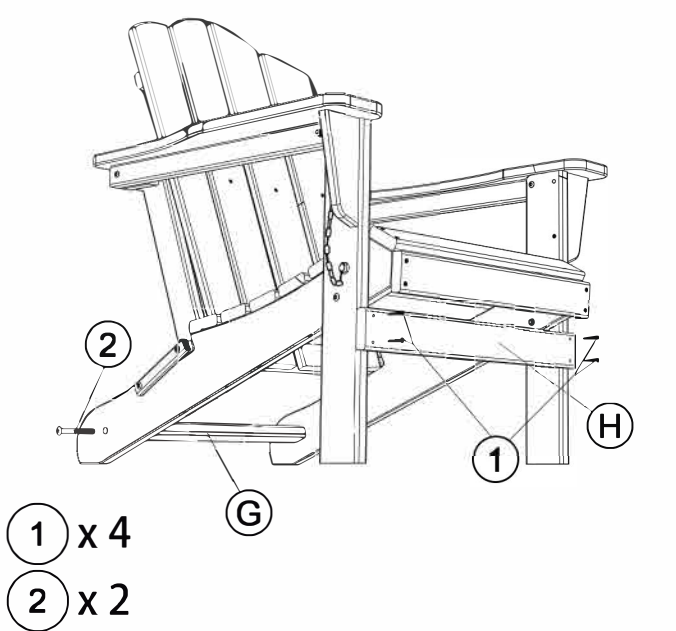

- STEP 3**
- Attach "Front Stretcher (H)" to "Chair Legs (B/C)" - Using "① M6 x 40MM Screws", tighten with screwdriver.
  - Attach "Back Stretcher (G)" to "Chair Seat Frame (A)" - Using "② M6 x 40MM Bolts", tighten with Hex key.

- ① x 4
- ② x 2

## Folding Chair

This Adirondack chair can be easily folded flat by pulling out the "Plugs" inserted in the chair legs.

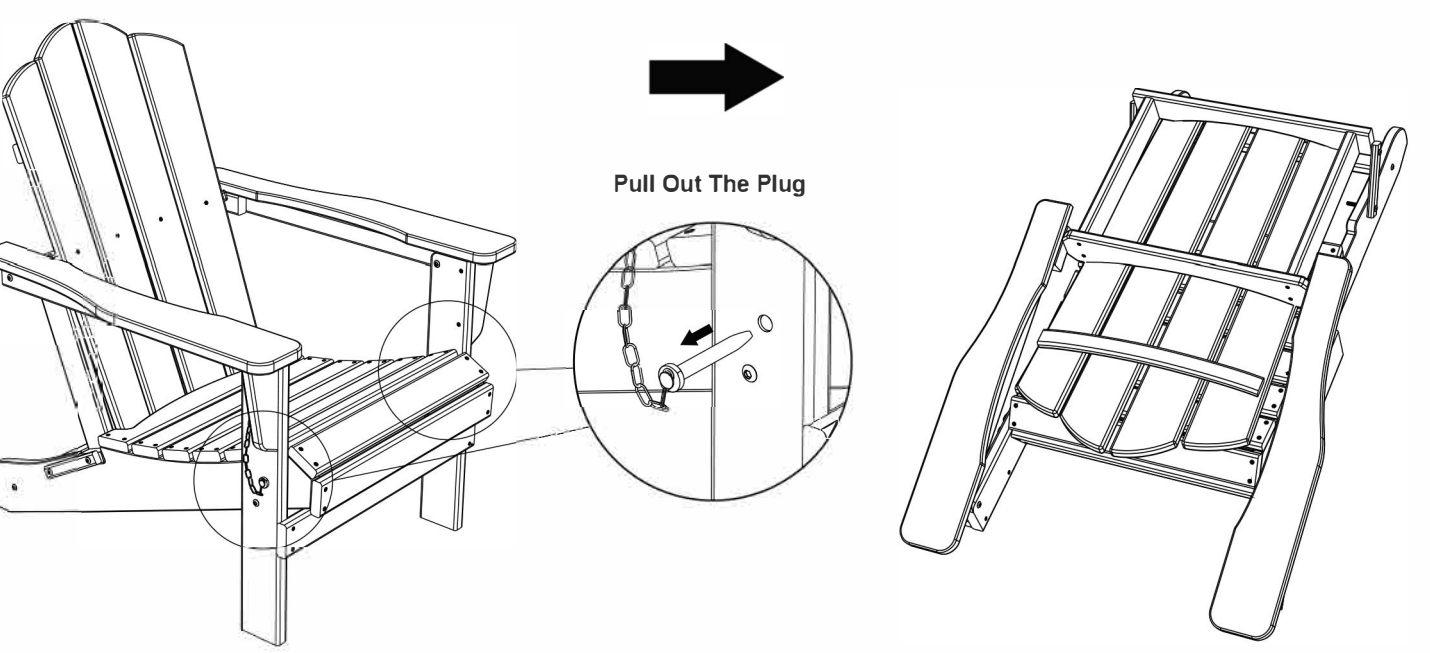

## Warnings

**Important** - Please read these instructions fully before starting assembly

- Check you have all the components and tools listed on the page 2.
- Remove all fittings from the plastic bags and separate them into their groups.
- Keep children and animals away from the work area, small parts may cause choking if swallowed.
- Make sure you have enough space to layout the parts before starting.
- Assemble on a soft level surface to avoid damaging the unit or your floor.
- Do not stand or put weight on the product, this could cause damage.
- Assemble the item as close to its final position (in the same area) as possible.
- Do not place furniture directly in front of radiators, fires, or any other source of heat.

The assembly will be easier with 2 people while 1 person could also do the job.

Refer to the LISTING page for specific installation videos.

## Cleaning & Maintenance

- Clean the product with a solution of mild soap and water. Dip a soft cloth or sponge into the solution and wipe down the entire surface.
- After cleaning, thoroughly rinse the furniture with water to remove any remaining soap residue.
- When not in use, cover the product with a protective cover to keep it clean and prolong its lifespan.