

# ASSEMBLY INSTRUCTION

Step 1, Use horizontal bar, part C, to connect two legs, part B. Tighten screws E and F in 50%, do not tighten fully in this step.

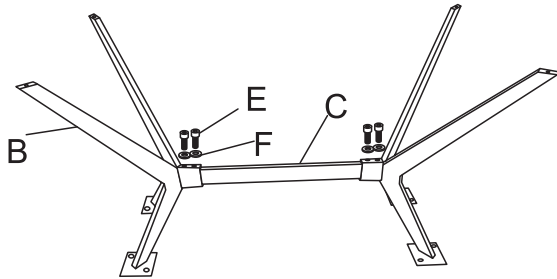

Step 2, Attach leg frames, part B, to the table top, part A. Tighten screws D and F in 50% with Allen Key H, do not tighten fully in this step.

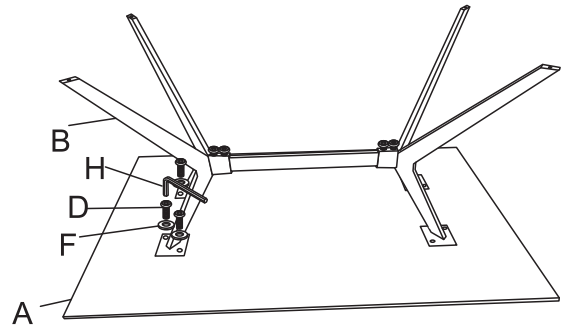

Step 3, Place adjustable foot protectors, part G, on table legs, part B, and tighten them slightly.

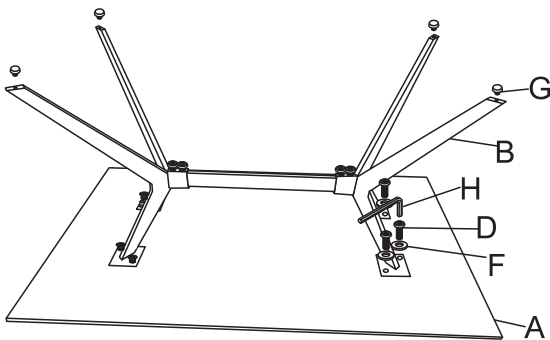

Step 4, Tighten all screws 100% in this step. Reverse the table and place it in an even surface to check if all legs are at the same level. If not, adjust part G to reach the balance.

