

ASSEMBLY GUIDE
GUIDE D'ASSEMBLAGE
INSTRUCCIONES DE ENSAMBLAJE

60W Double Pedestal Desk
Bureau à deux caissons 60L
Escritorio de pedestal doble 60An

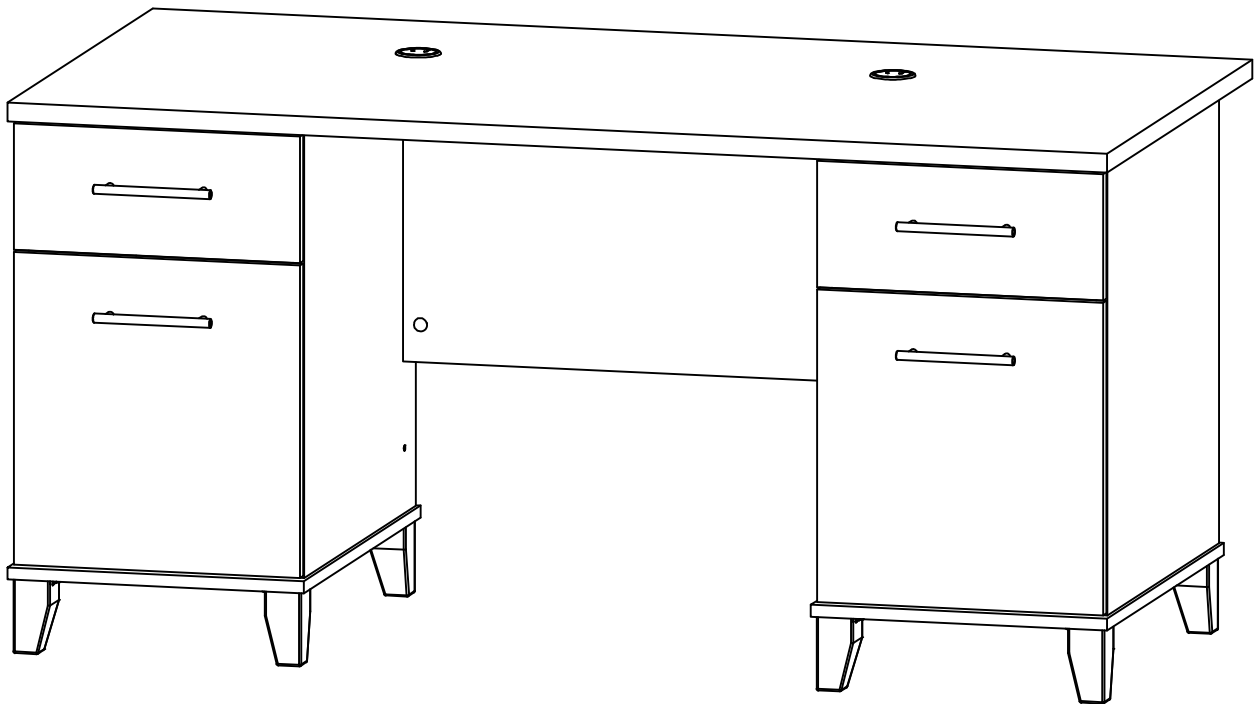

△ NOTE:

If there are parts missing from your order or if your product was damaged during shipping, PLEASE CONTACT US DIRECTLY.

△ NOTE :

S'il vous manque des pièces ou si votre meuble a été endommagé pendant le transport, VEUILLEZ NOUS CONTACTER DIRECTEMENT.

△ NOTA:

En caso de piezas faltantes o si su producto fue dañado durante el envío, POR FAVOR CONTACTENOS DIRECTAMENTE.

IMPORTANT SAFETY INFORMATION



PLEASE READ WARNINGS

Improper use can cause safety hazards, or damage to your furniture and household items.

Warning	Do	Don't	Why it's important
Serious injury may occur.	<ul style="list-style-type: none">Assemble following all instructions using all indicated parts and hardware provided.	<ul style="list-style-type: none">Do not move unit when loaded.Do not load with a television or other heavy equipment.Do not exceed the maximum load limits stated in the instructions.	Improper assembly, use or loading can lead to product instability, tipover, or collapse.

Advertencia	Hacer	No	Por qué es importante
Pueden producirse lesiones graves.	<ul style="list-style-type: none">Realice el montaje siguiendo todas las instrucciones y utilizando todas las piezas indicadas y los herrajes suministrados.	<ul style="list-style-type: none">No mueva la unidad cuando esté cargada.No cargue el mueble con un televisor u otro equipo pesado.No supere los límites máximos de carga indicados en las instrucciones.	El montaje, uso o carga inadecuados pueden provocar inestabilidad, vuelco o colapso del producto.

Avertissement	À faire	À ne pas faire	Pourquoi c'est important
Peut entraîner des blessures graves.	<ul style="list-style-type: none">Assembler en suivant toutes les instructions et en utilisant toutes les pièces et la quincaillerie incluses.	<ul style="list-style-type: none">Ne pas déplacer le meuble lorsqu'il est chargé.Ne pas charger le meuble avec un téléviseur ou tout autre équipement lourd.Ne pas dépasser les limites de poids maximales indiquées dans les instructions.	Un assemblage, une utilisation ou un chargement incorrects peuvent entraîner l'instabilité, le basculement ou l'effondrement du produit.

Parts - Pièces - Piezas

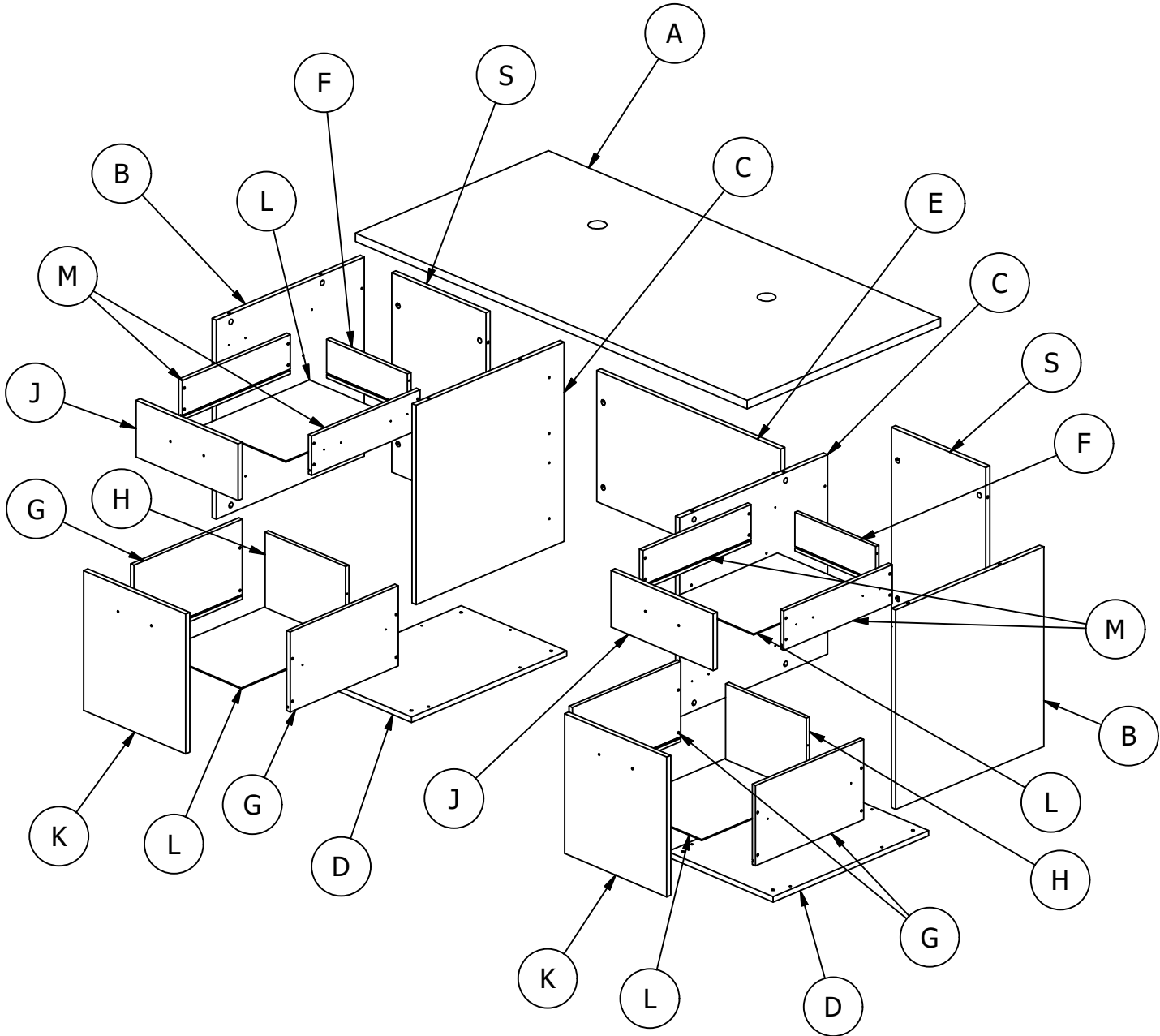
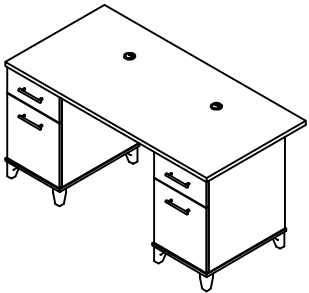

Fasteners - Fixations - Sujetadores

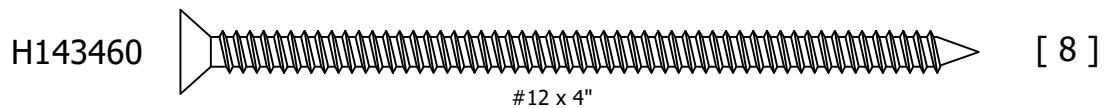
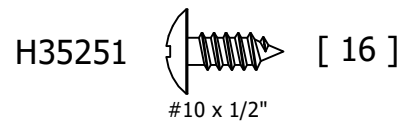
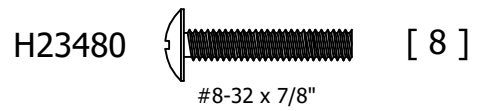
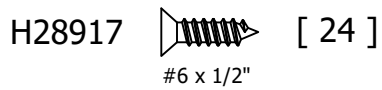
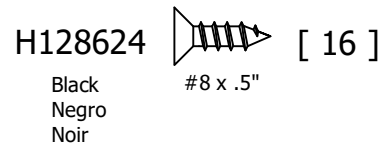
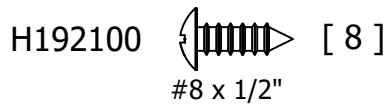
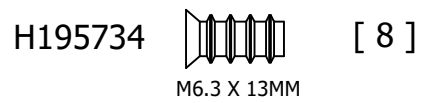
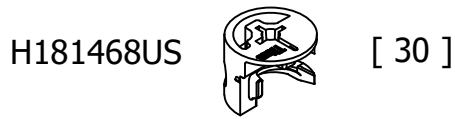
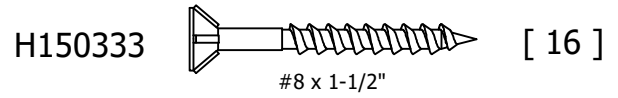
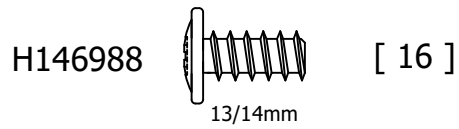

Hardware - Quincaillerie - Quincaillas

Not to Scale - No a escala - Pas à l'échelle.

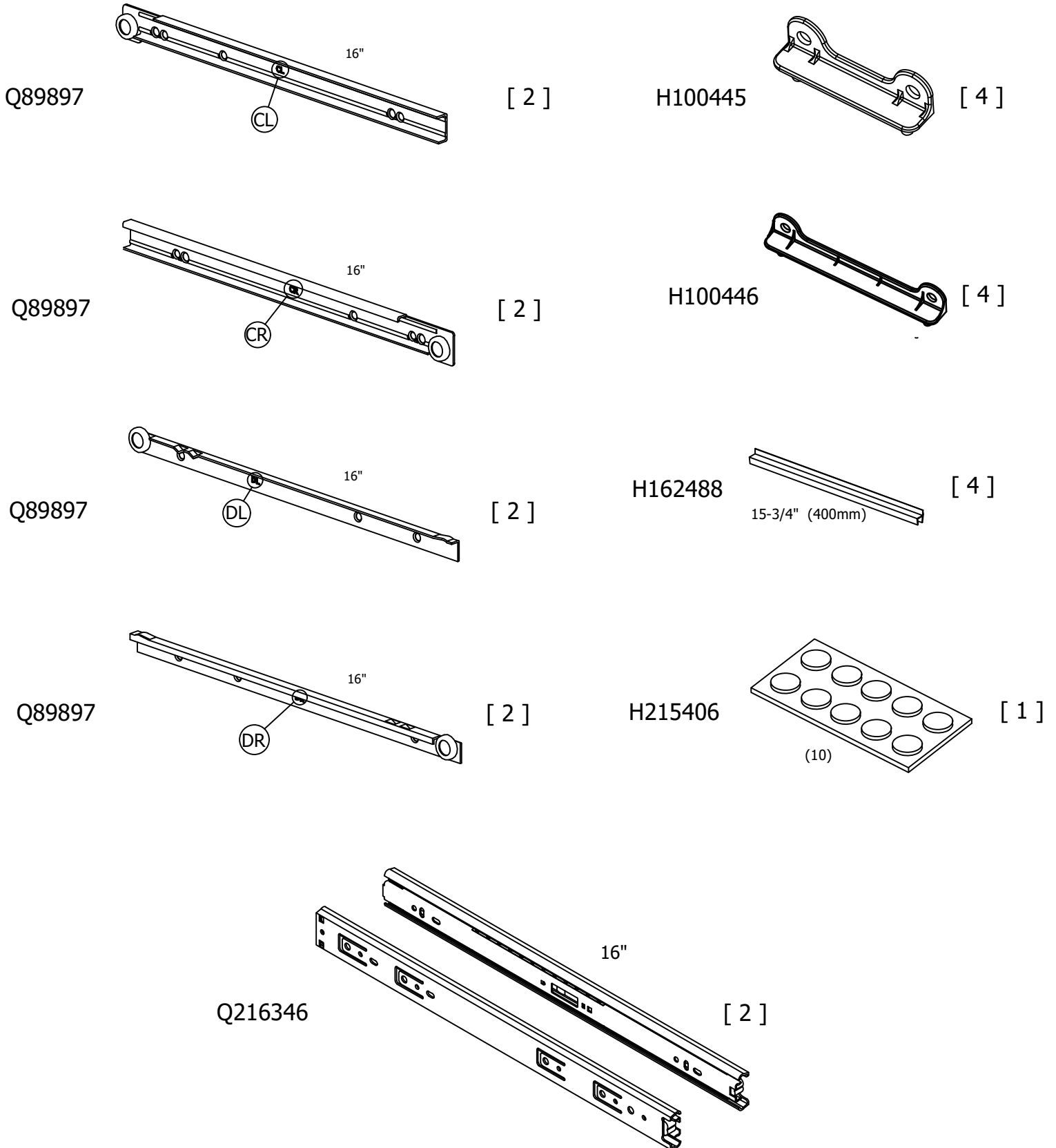

Hardware - Quincaillerie - Quincaillas

Not to Scale - No a escala - Pas à l'échelle.

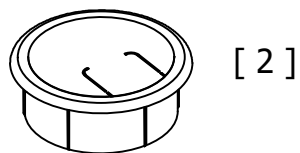
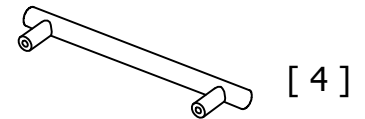
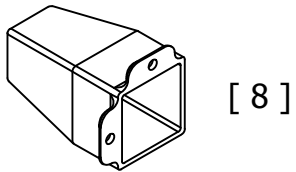
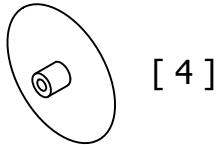

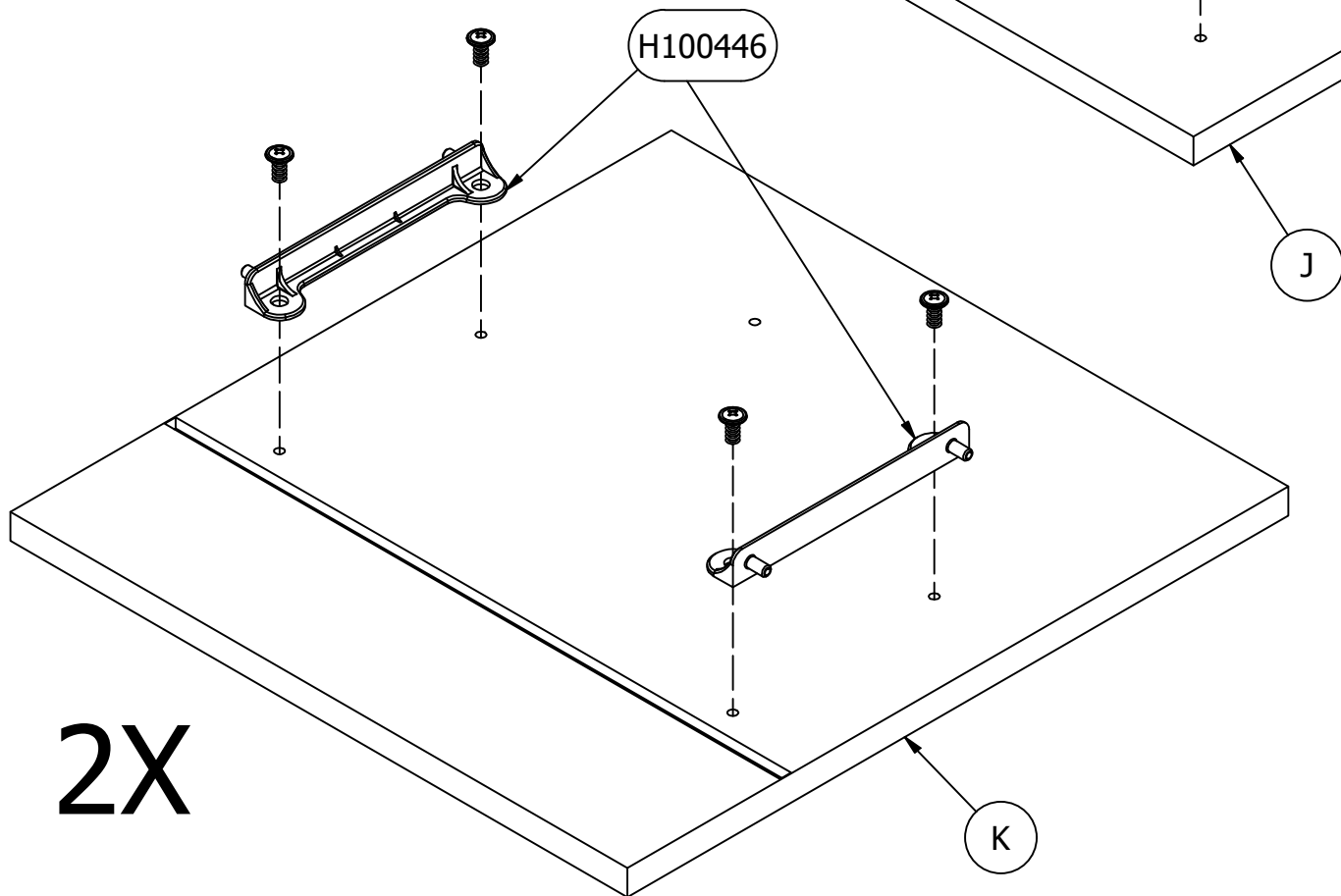
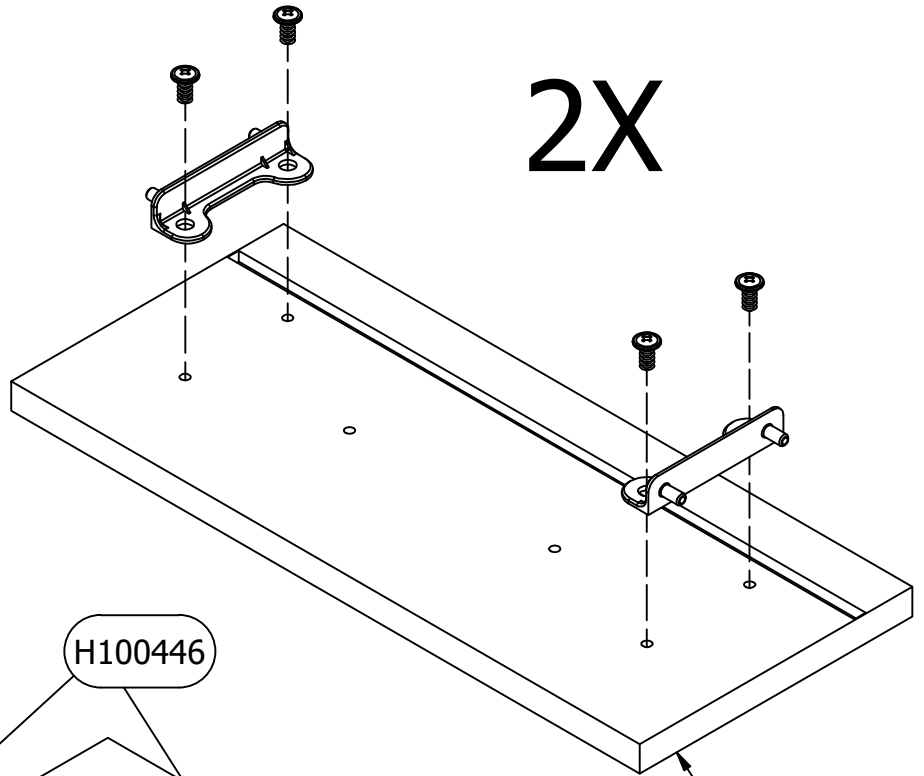
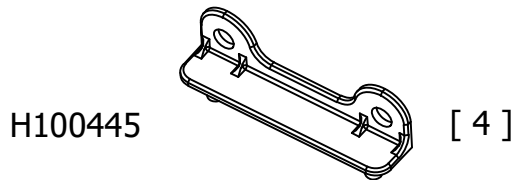
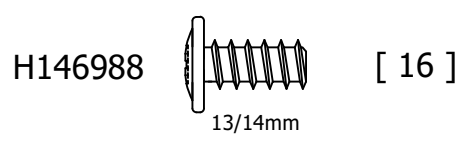
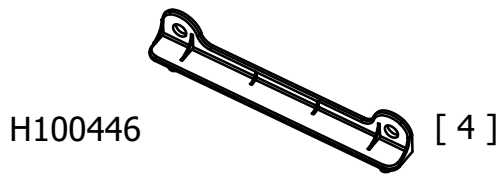

H128624 [8]



Black
Negro
Noir

#8 x .5"

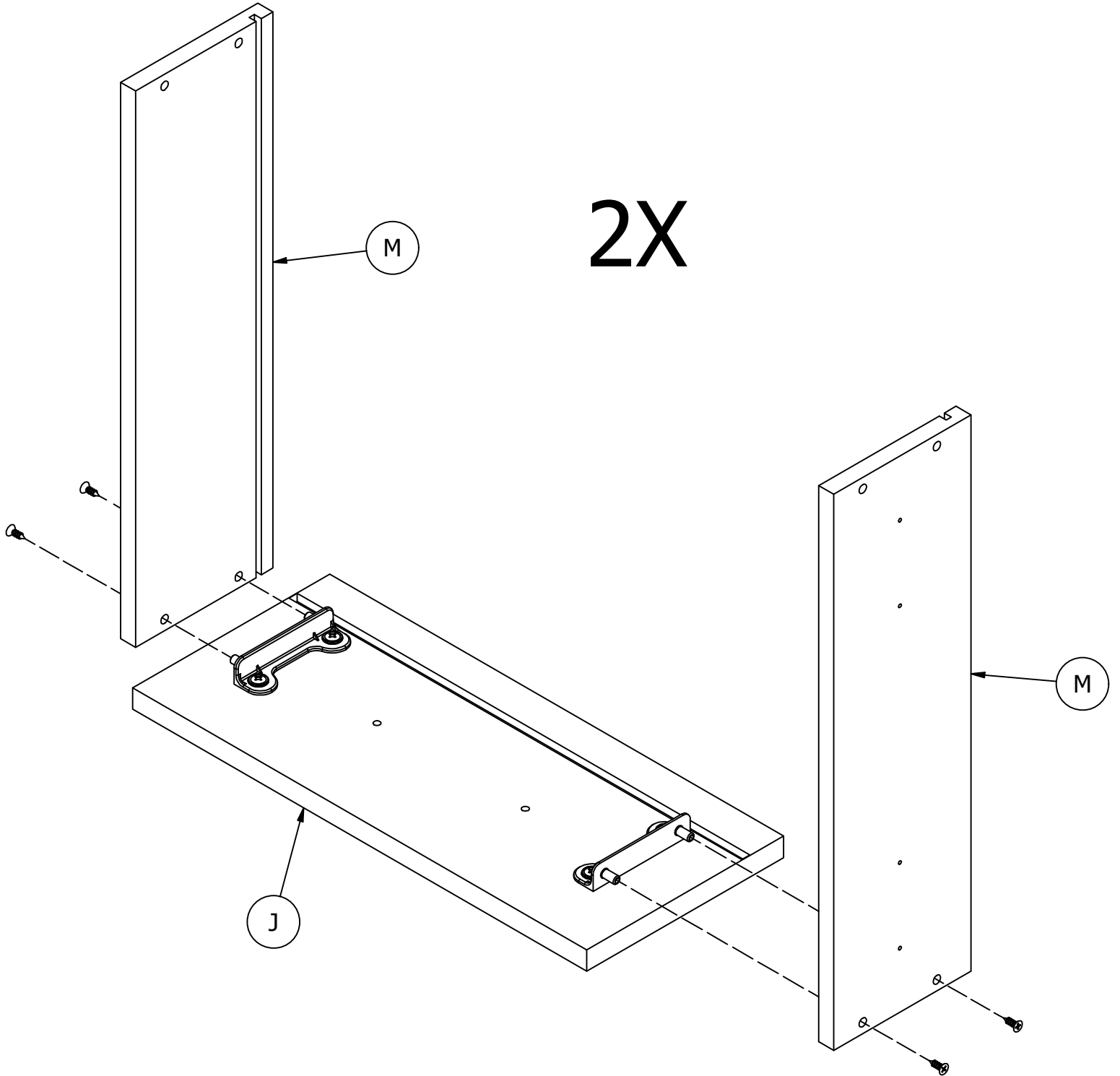

H150333

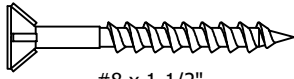

#8 x 1-1/2"

[8]

2X

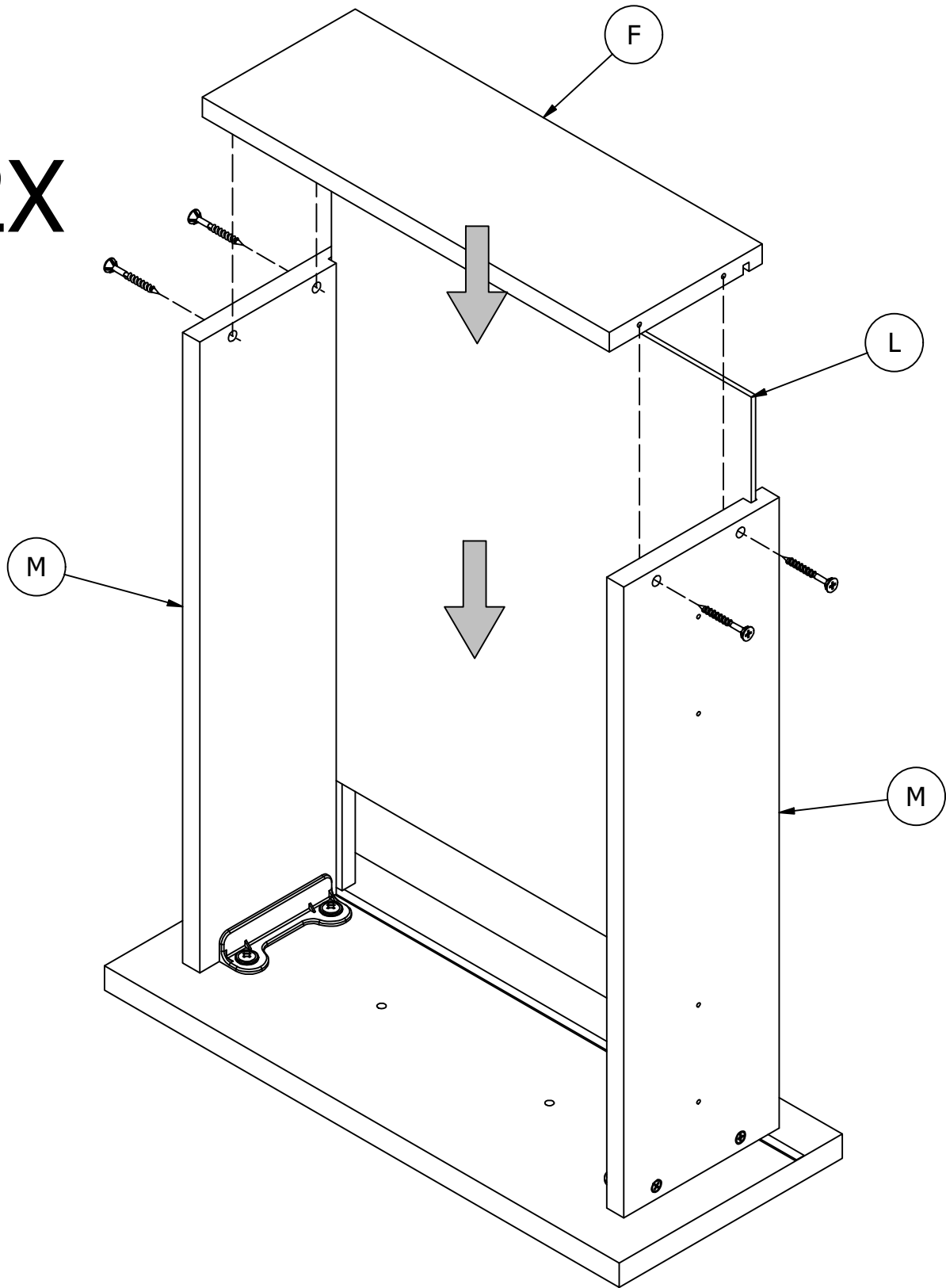

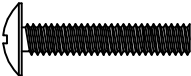
H23480  [4]
#8-32 x 7/8"

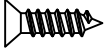
H28917  [12]
#6 x 1/2"

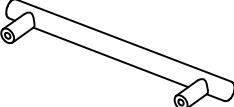
 [2]

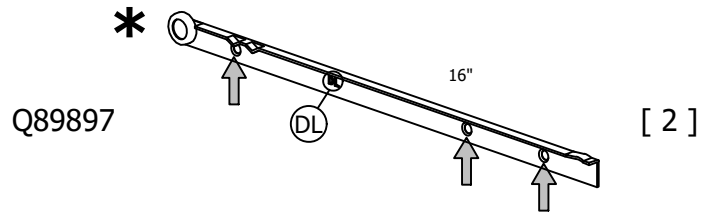
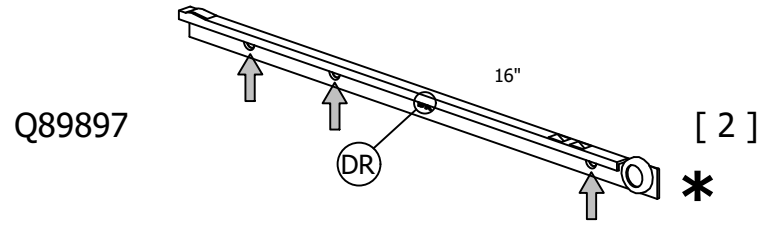

2X

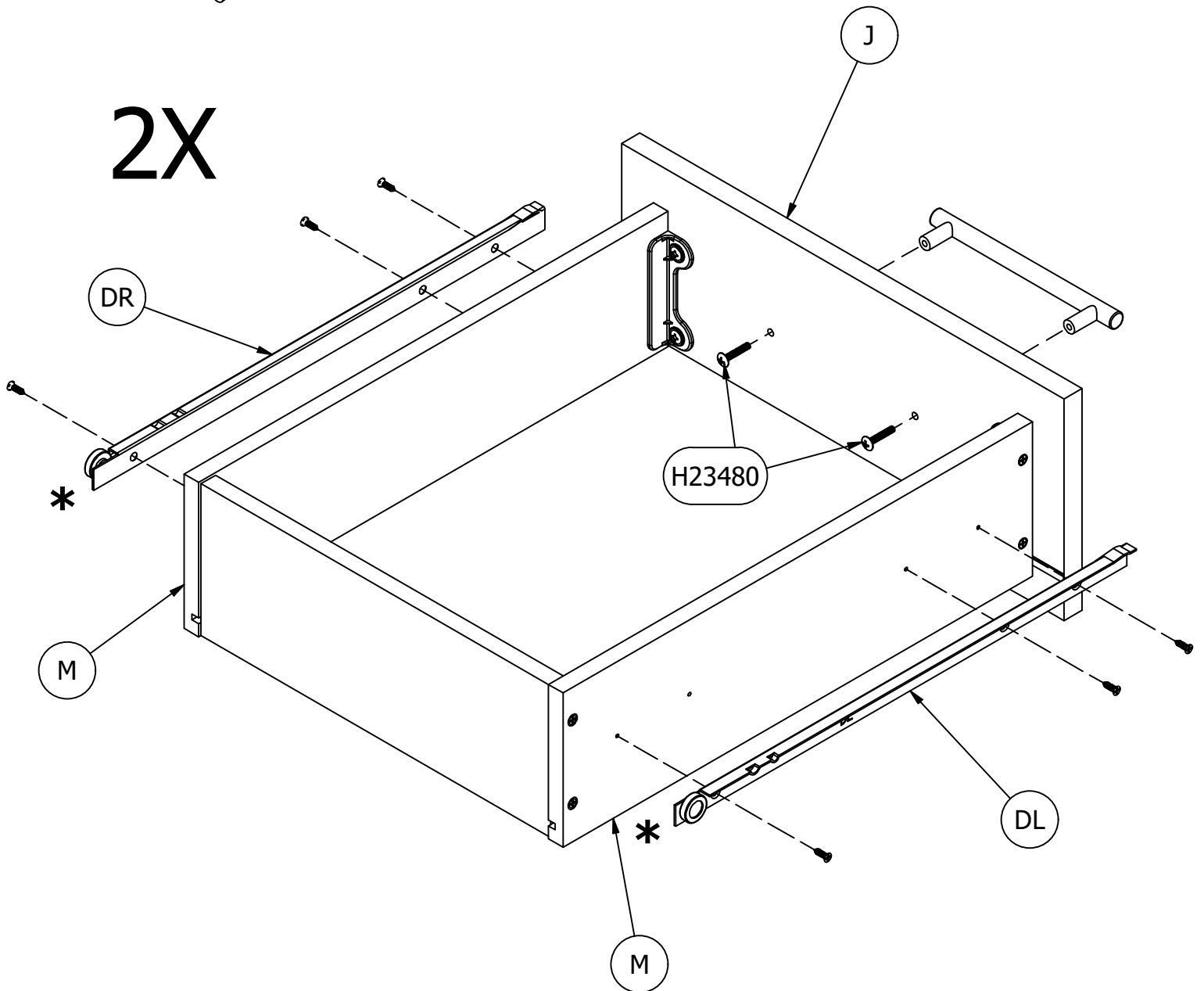

H128624



[8]

Black
Negro
Noir

#8 x .5"

2X

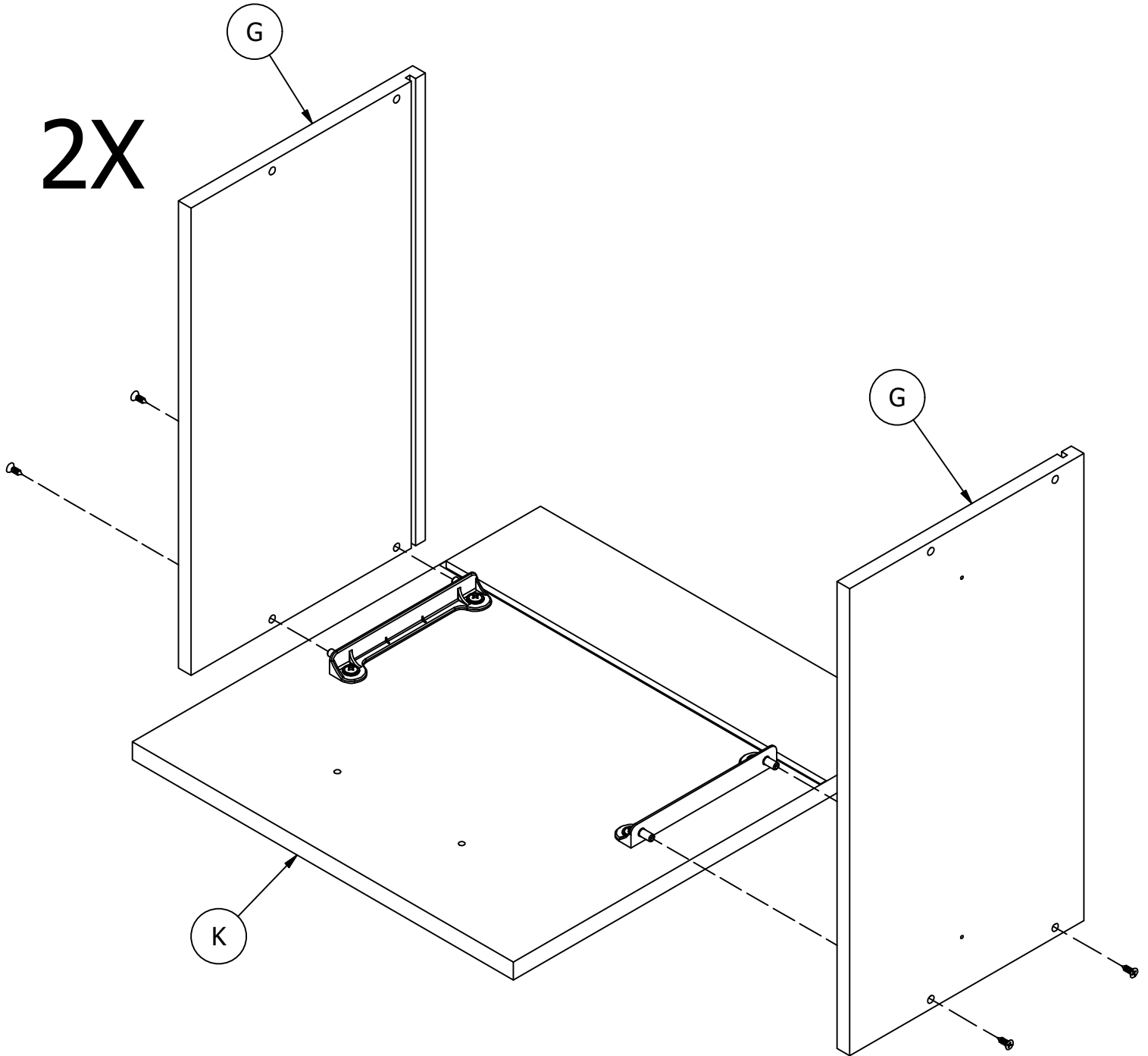

H150333



#8 x 1-1/2"

[8]

2X

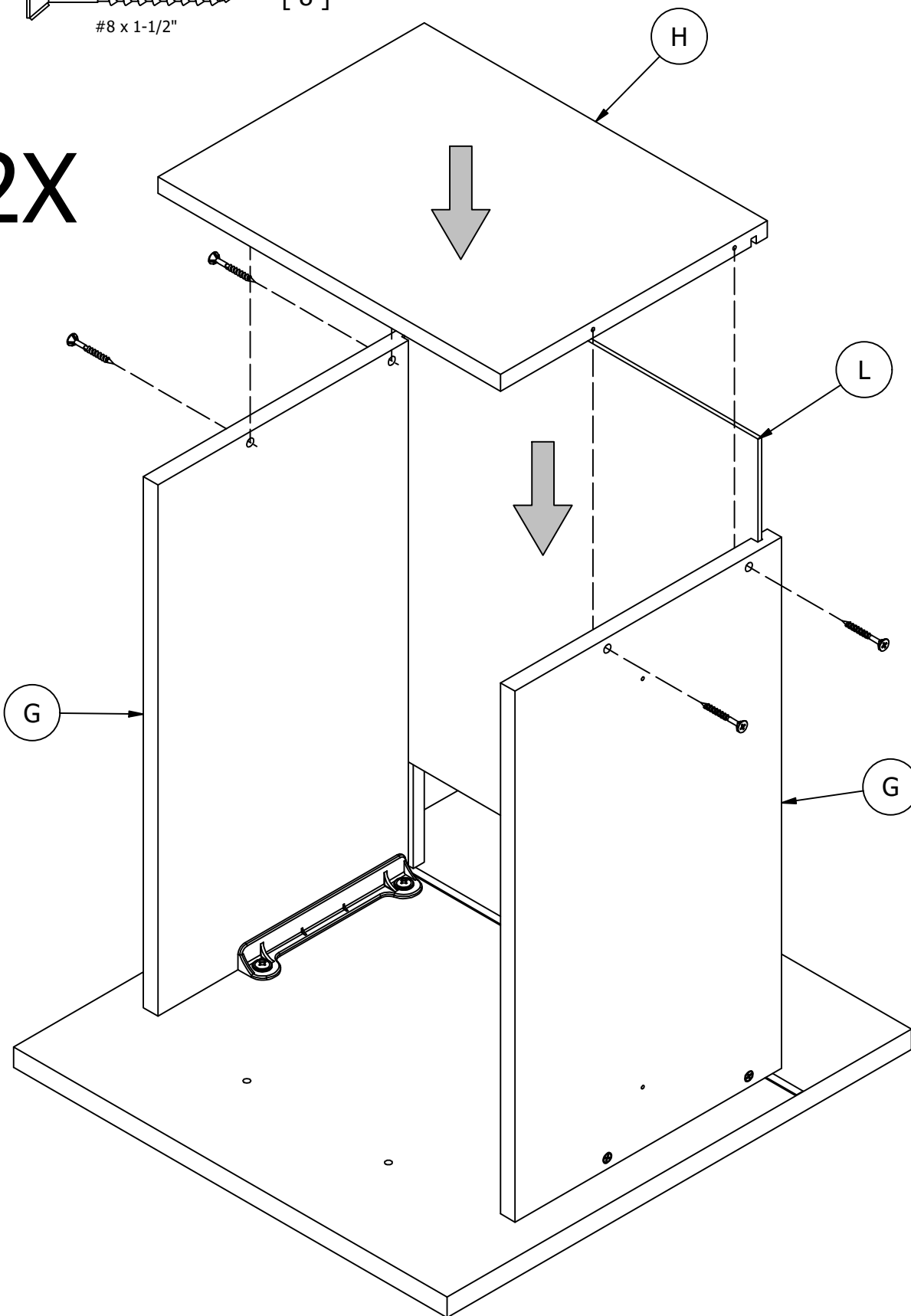

**Slides Must Be Separated Before Assembly.
After Separated, Set Aside Until Needed for Assembly.**

Las diapositivas deben separarse antes del montaje.
Después de la separación, déjelo a un lado hasta que sea necesario.

Les glissières doivent être séparées avant l'assemblage.
Après la séparation, mettez de côté jusqu'au moment de l'assemblage.

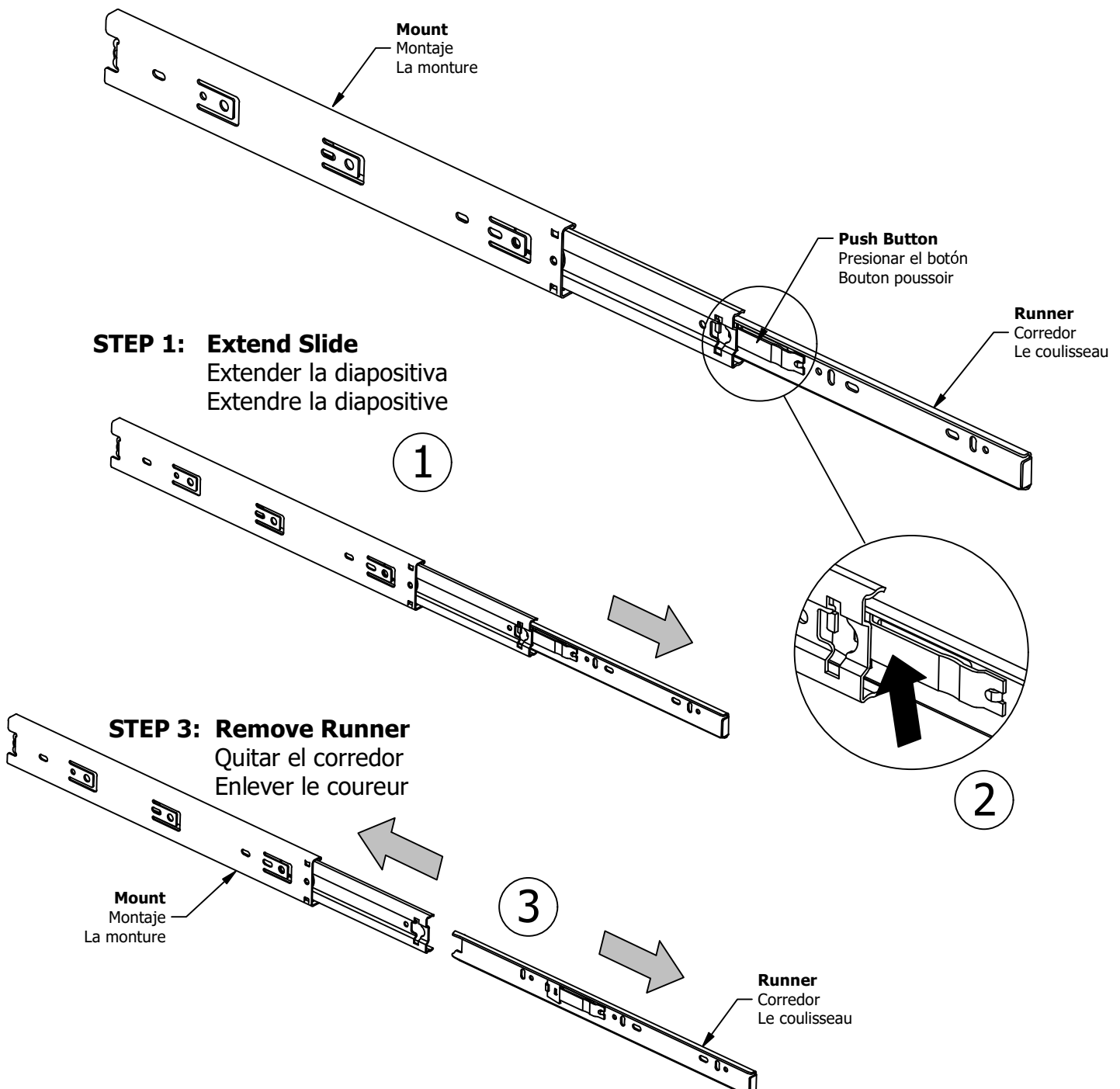

Attach - Fije - Fixer

H23480  [4]
#8-32 x 7/8"

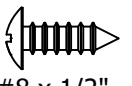
H192100  [8]
#8 x 1/2"

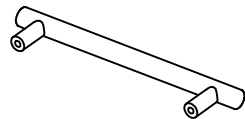
 [2]

Q216346

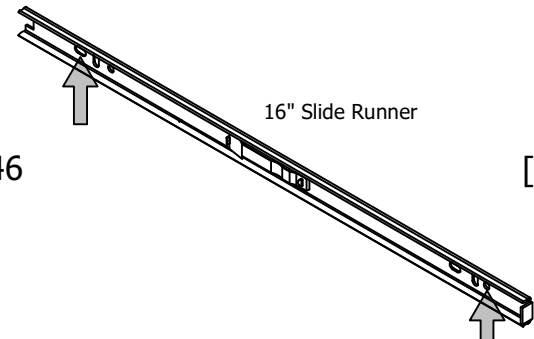
 16" Slide Runner [4]
Orientation
Orientación
L'orientation

2X

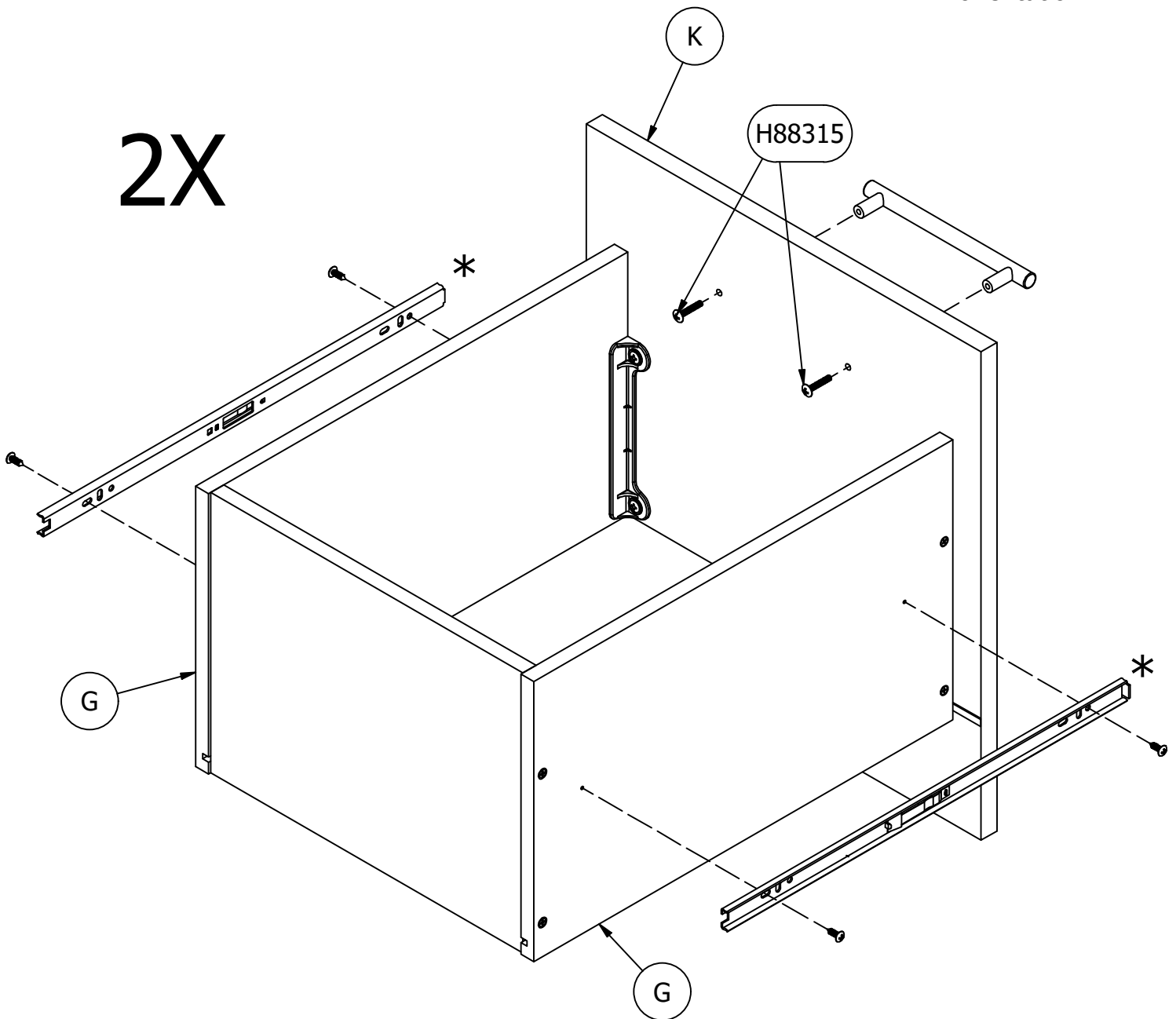

H162488

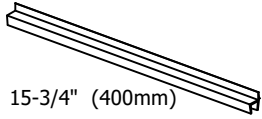

15-3/4" (400mm)

[4]

H215406



[8]

2X

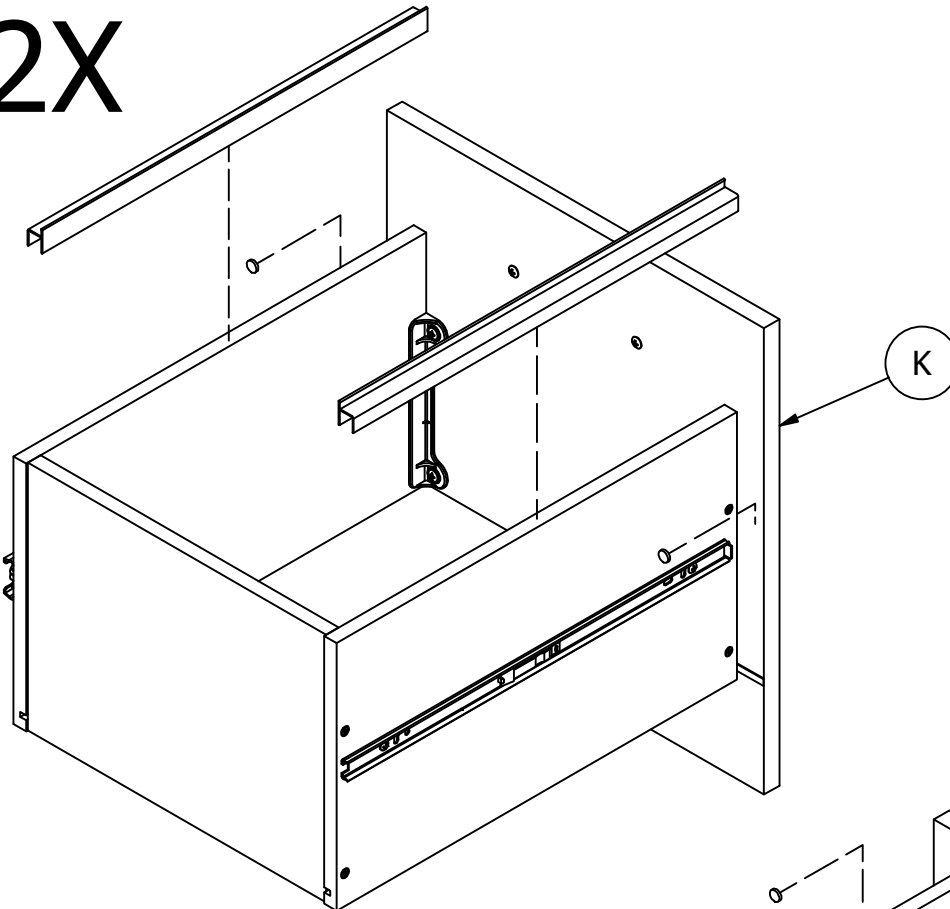

J

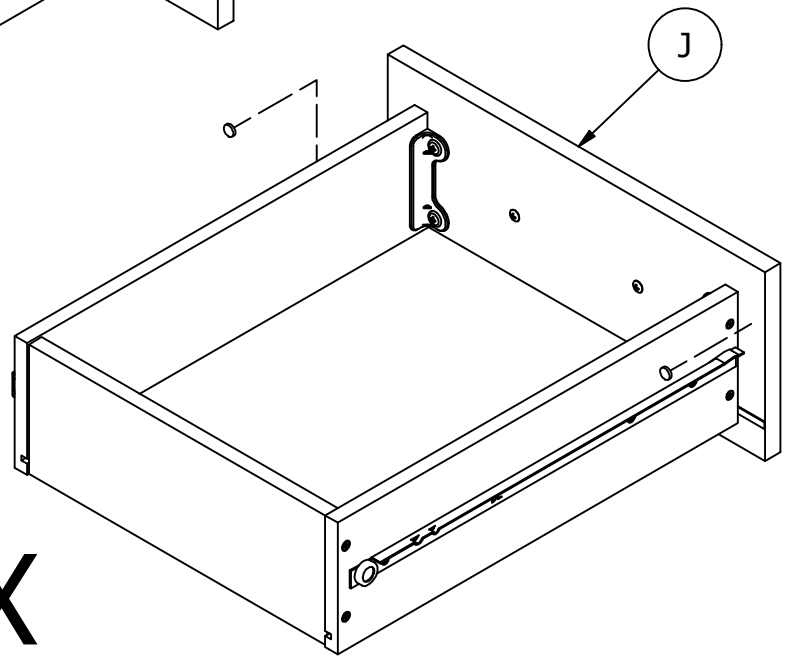

2X

H28917 [3]
#6 x 1/2"

H195734 [2]
M6.3 X 13MM

H72988 [2]

Q89897 [1]

Orientation
Orientación
L'orientation

Q216346 [1]

16" Slide Mount

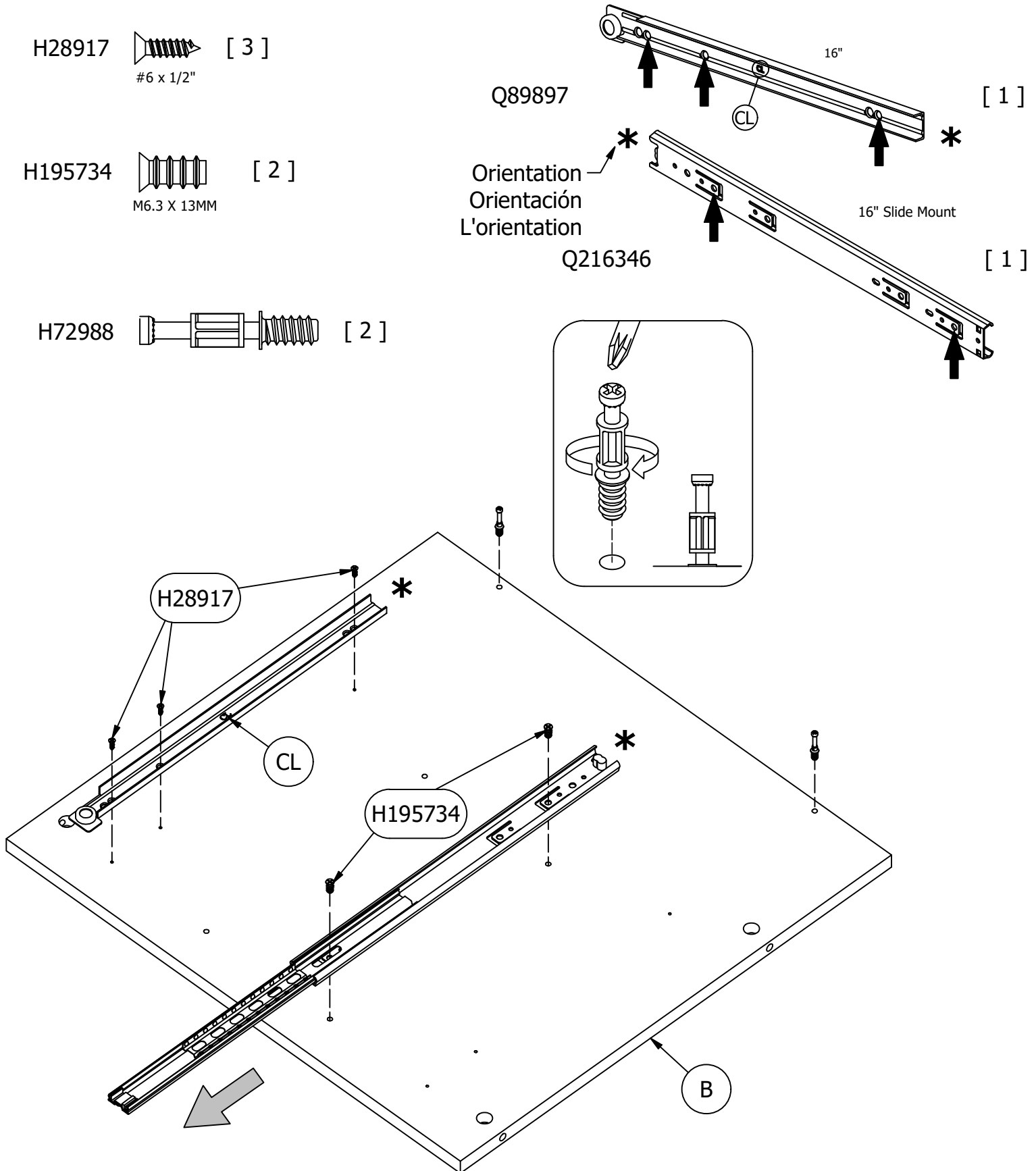

H28917 [3]
#6 x 1/2"

H195734 [2]
M6.3 X 13MM

H72988 [2]

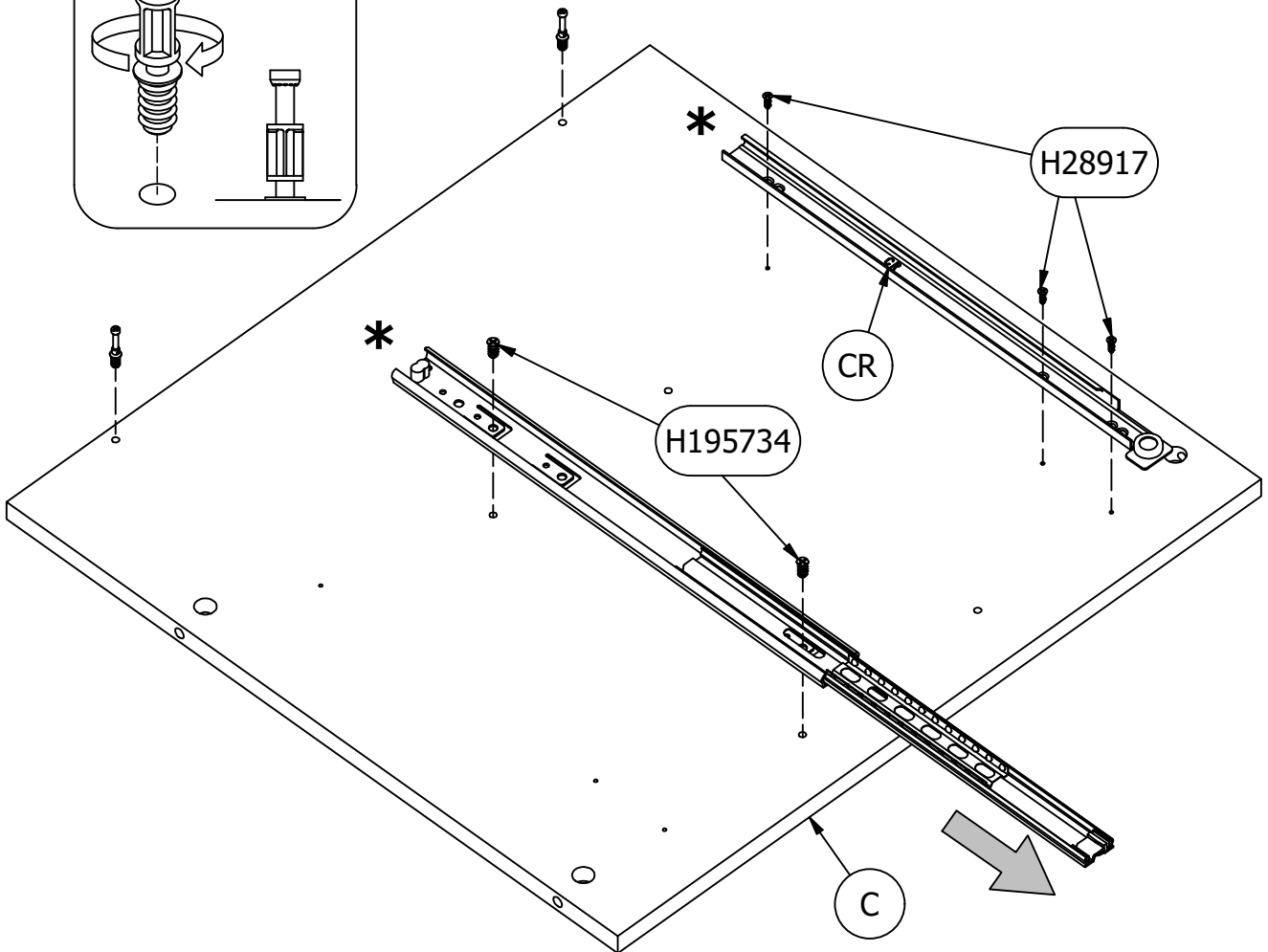
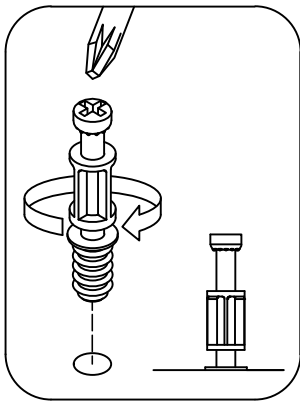
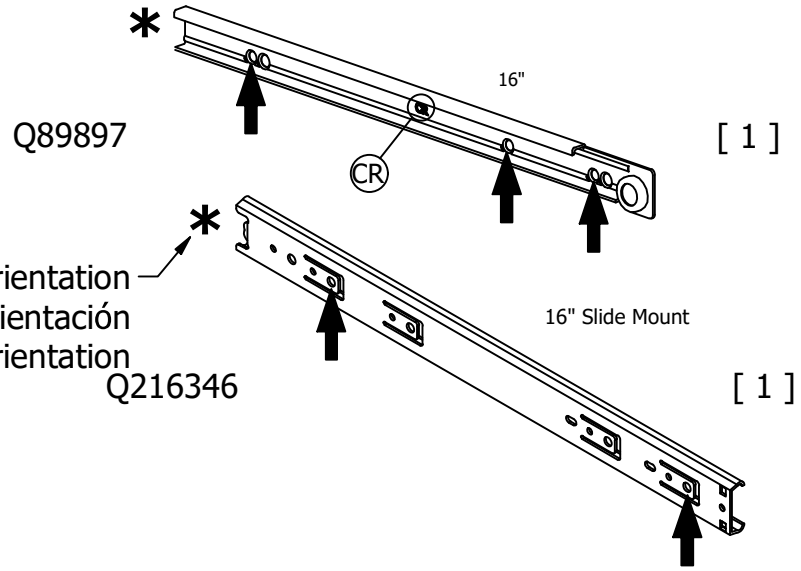

H181468US



[4]

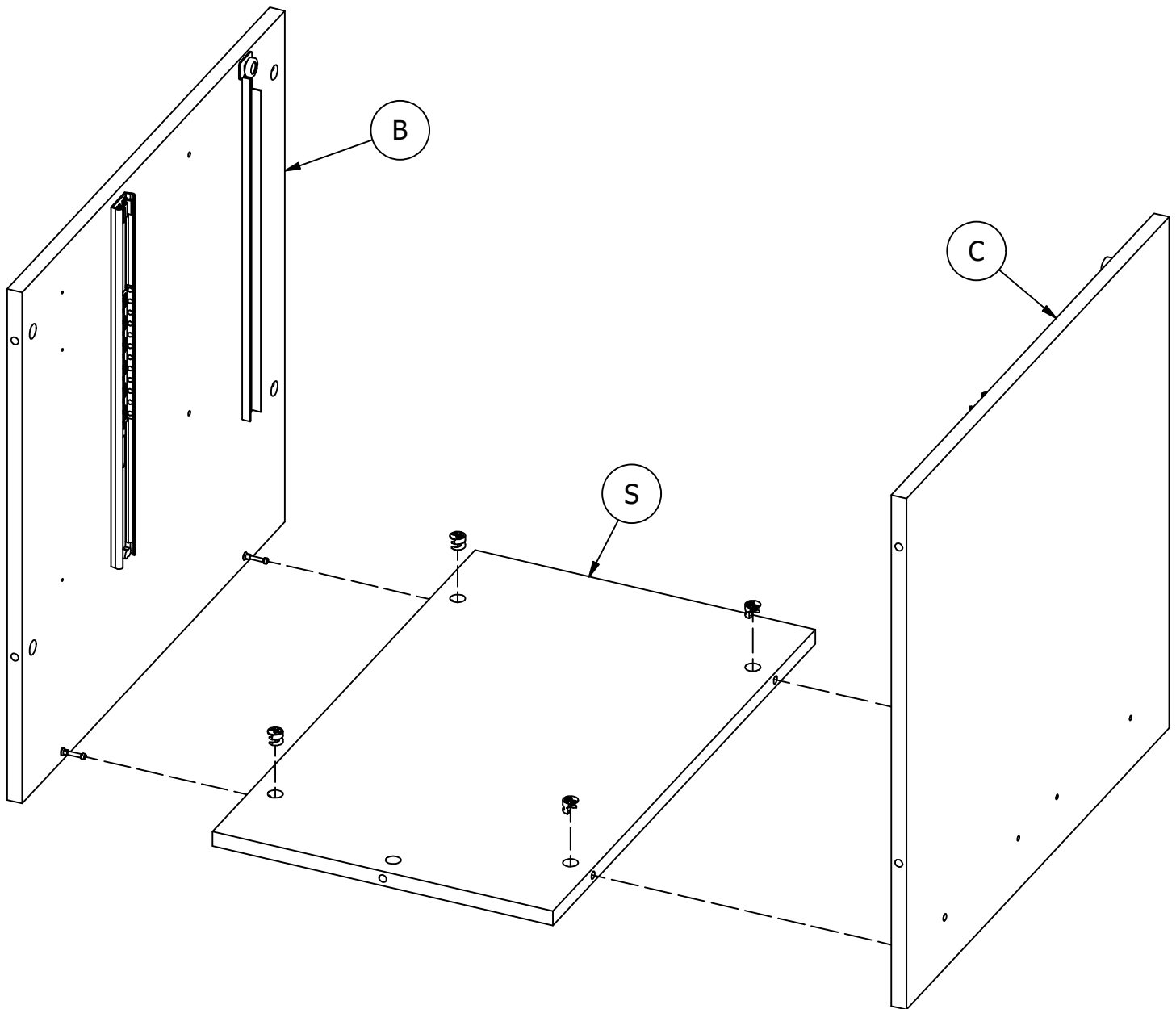
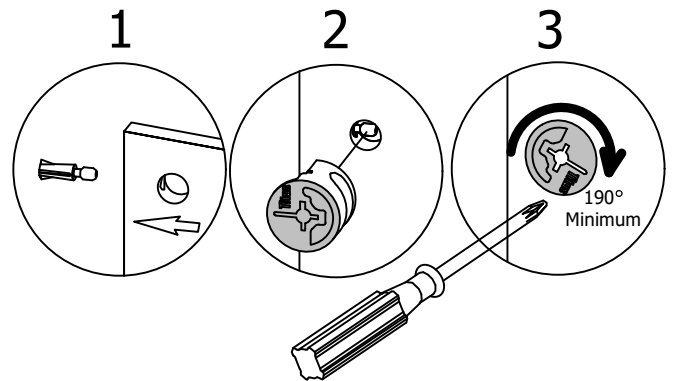

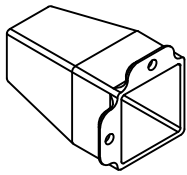

[4]

H35251

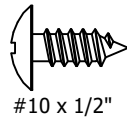

[8]

H72988

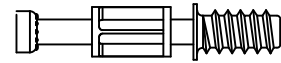

[5]

H143460

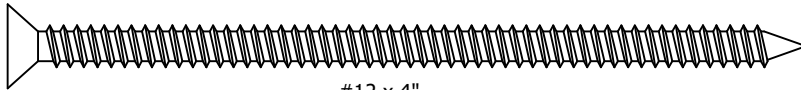

[4]

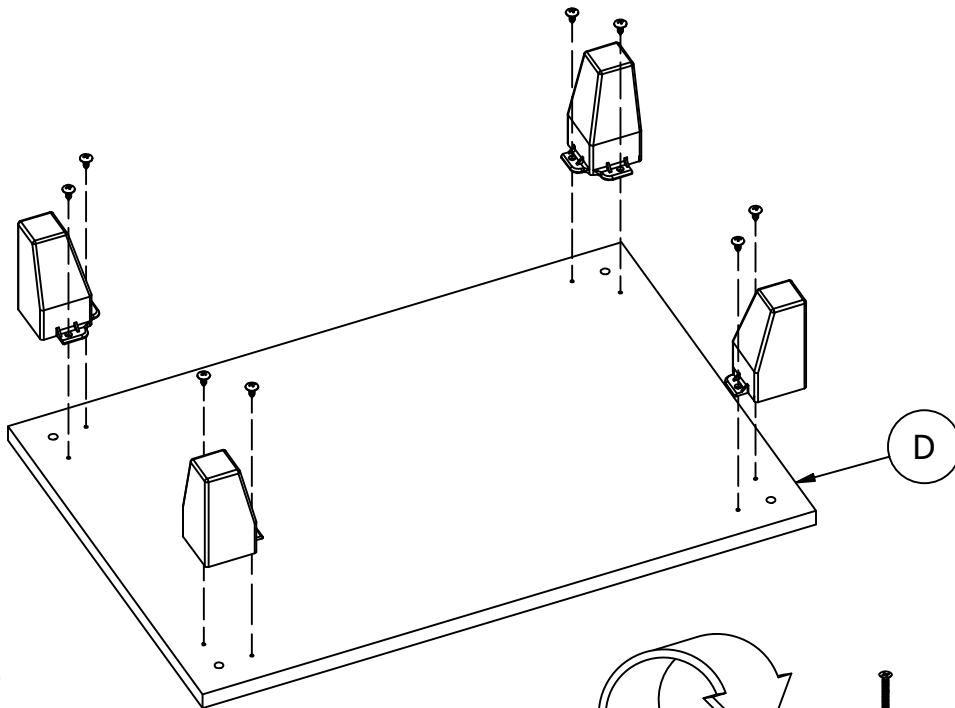

Flip panel over
Voltear el panel
Retournez le panneau

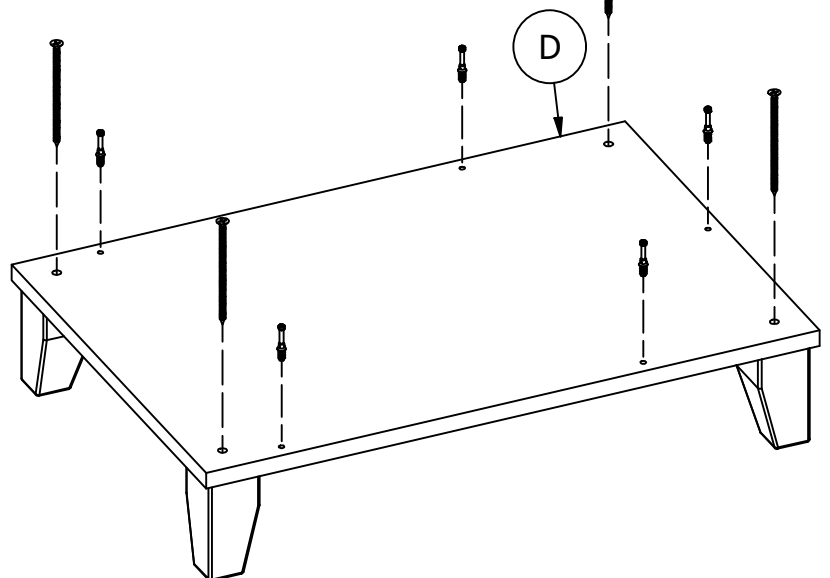
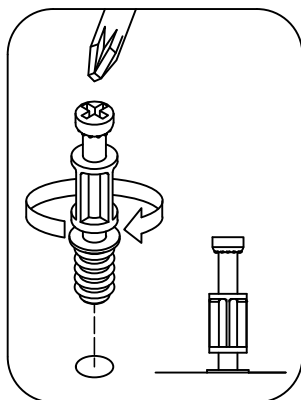

H72988 [2]

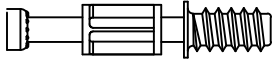

Q89897 [1]

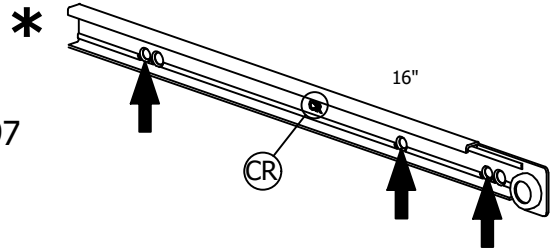

H195734 [2]

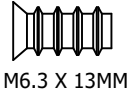

M6.3 X 13MM

Orientation
Orientación
L'orientation

Q216346 [1]

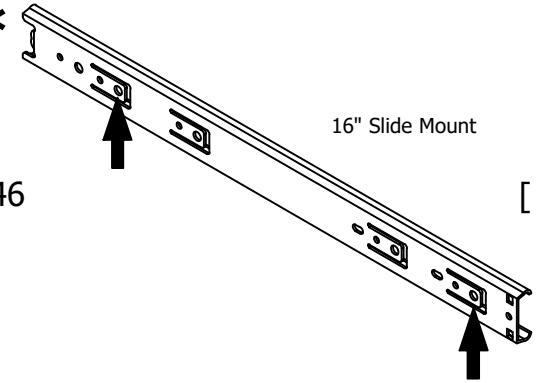

H28917 [3]

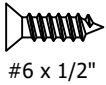

#6 x 1/2"

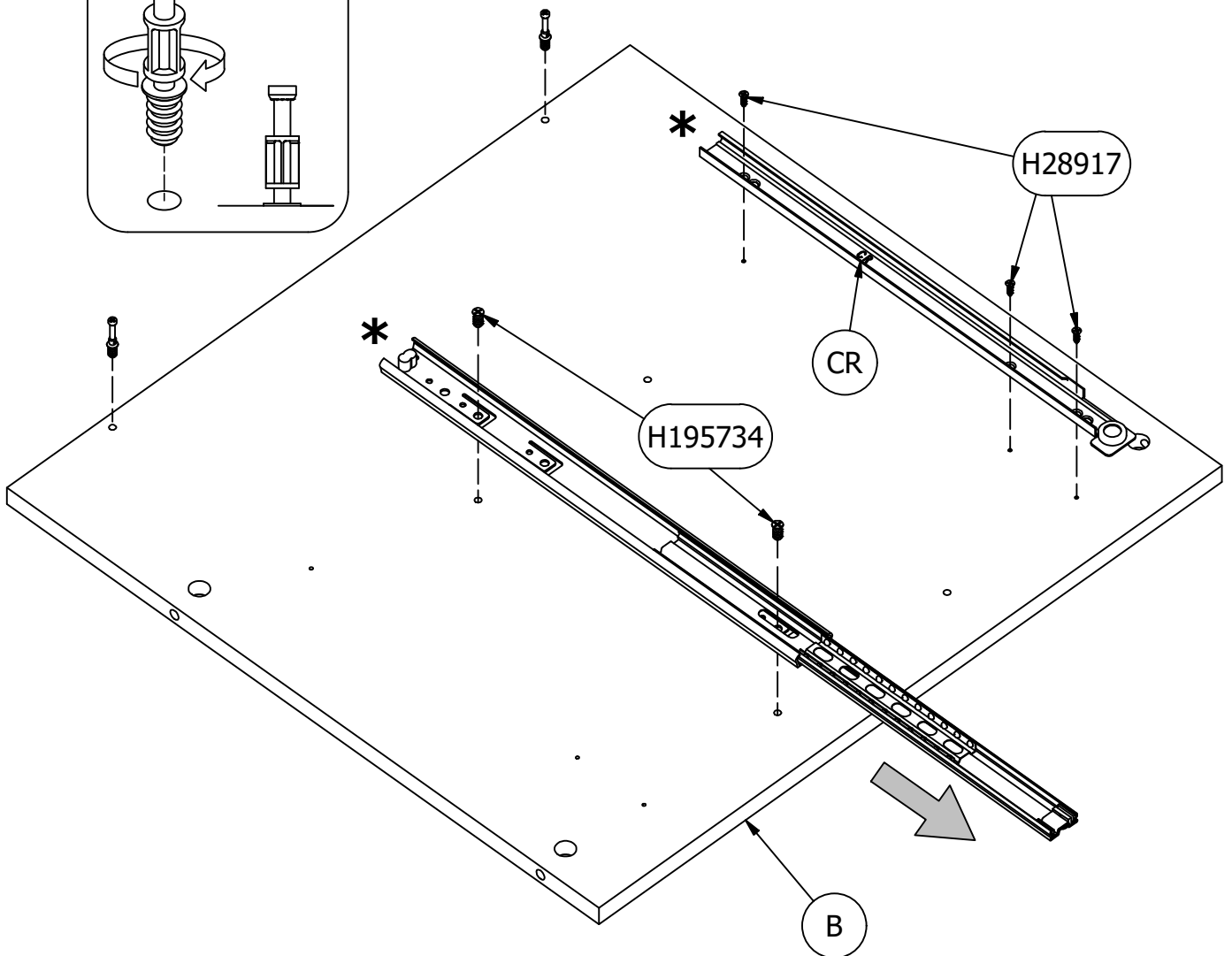
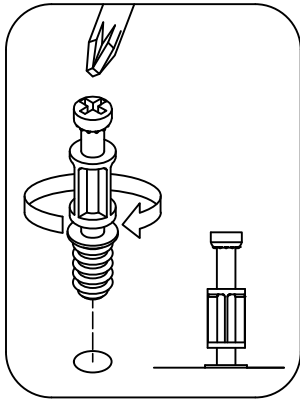

H72988 [2]

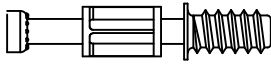

H195734 [2]

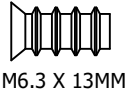

H28917 [3]

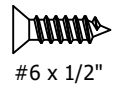

Q89897

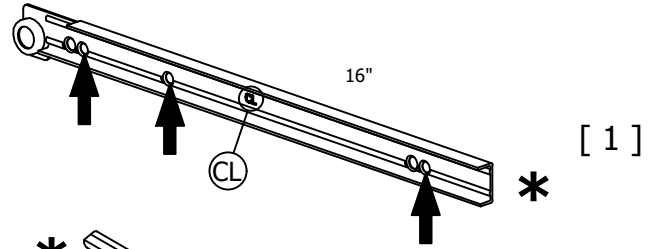

Orientation
Orientación
L'orientation

Q216346

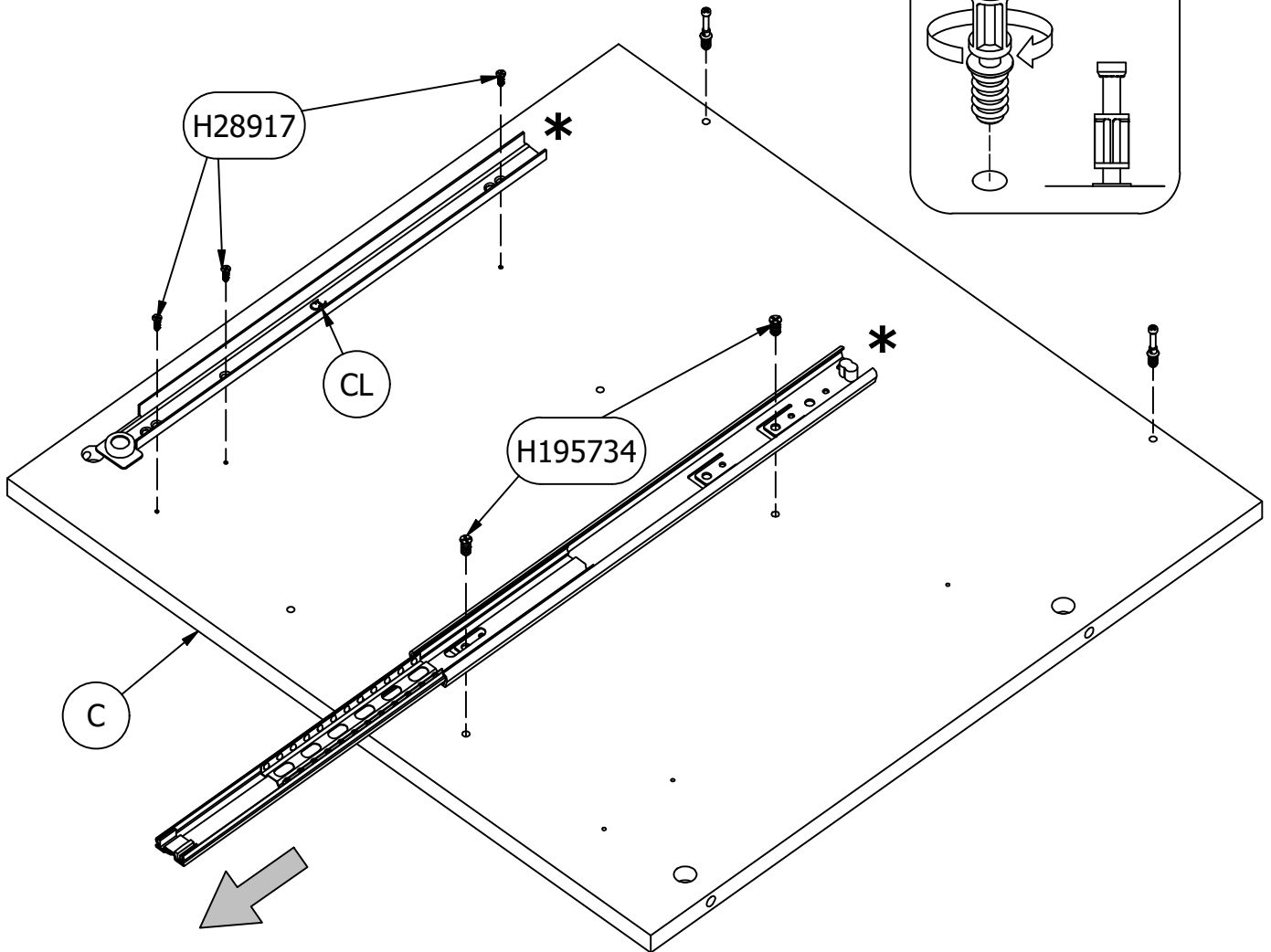
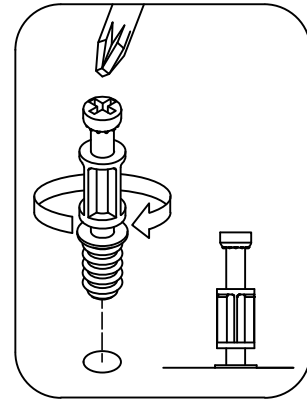
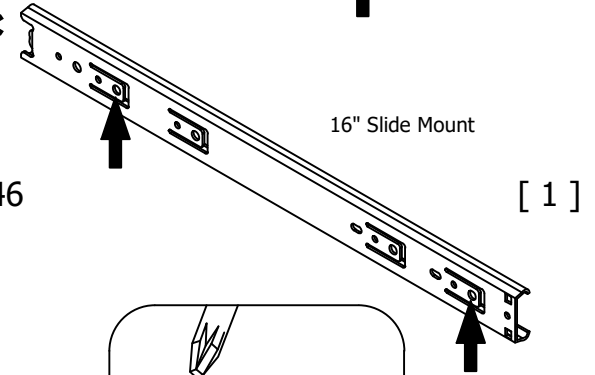

H181468US

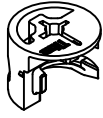

[4]

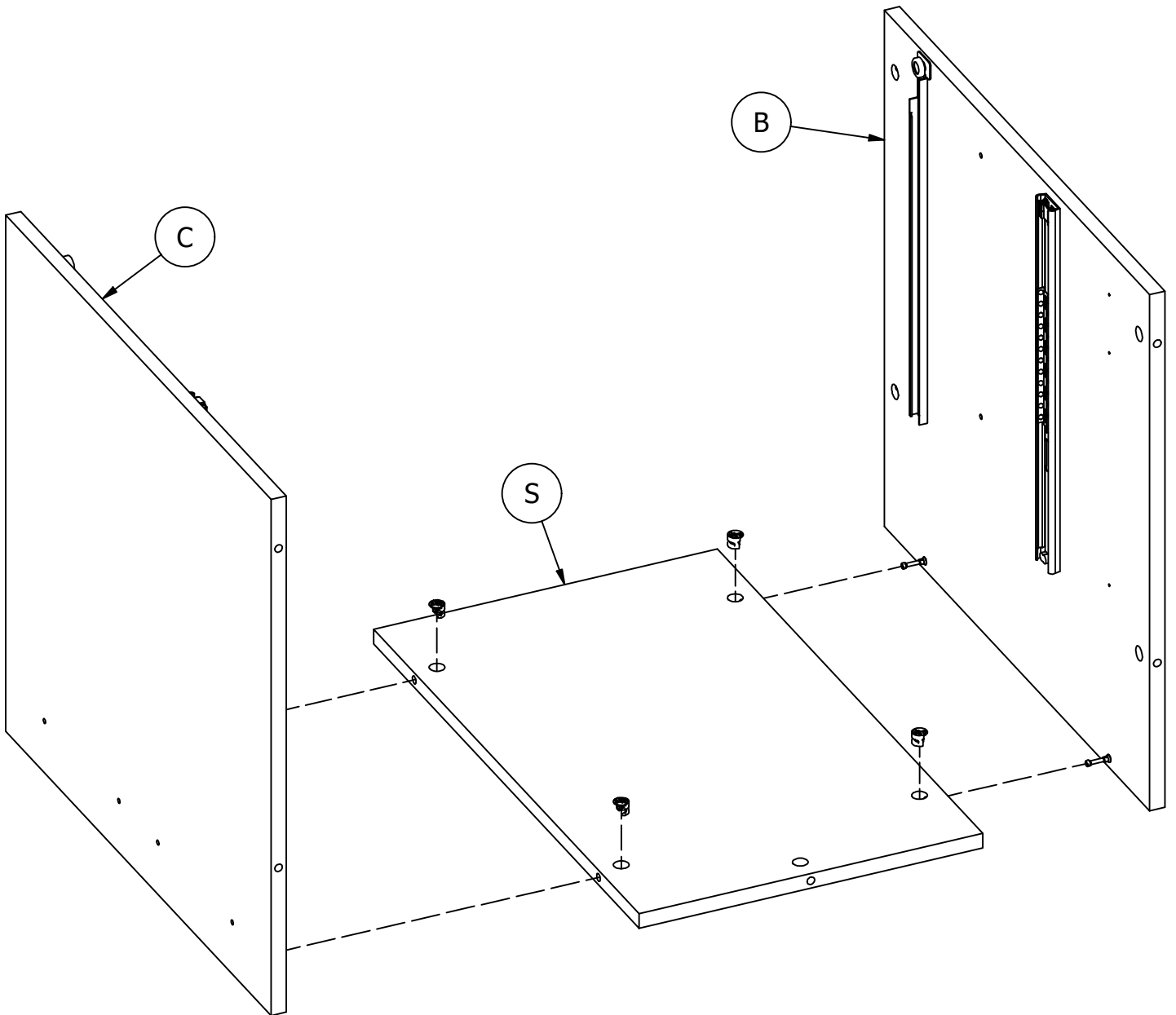
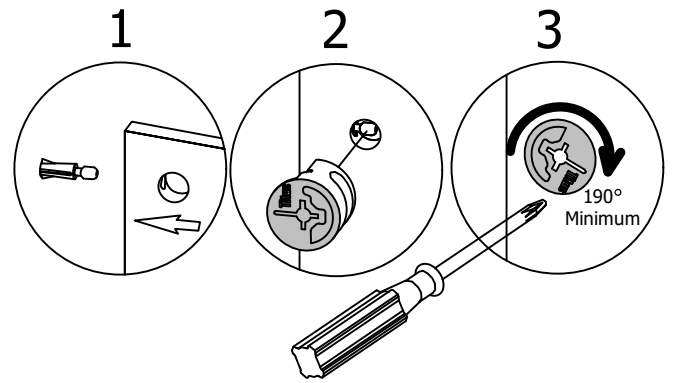

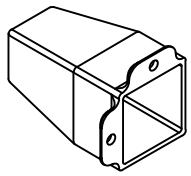

[4]

H35251

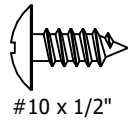

[8]

H72988

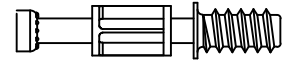

[5]

H143460

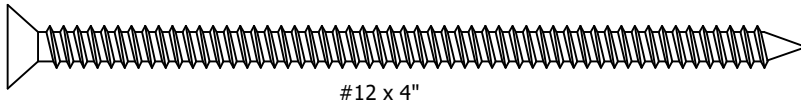

[4]

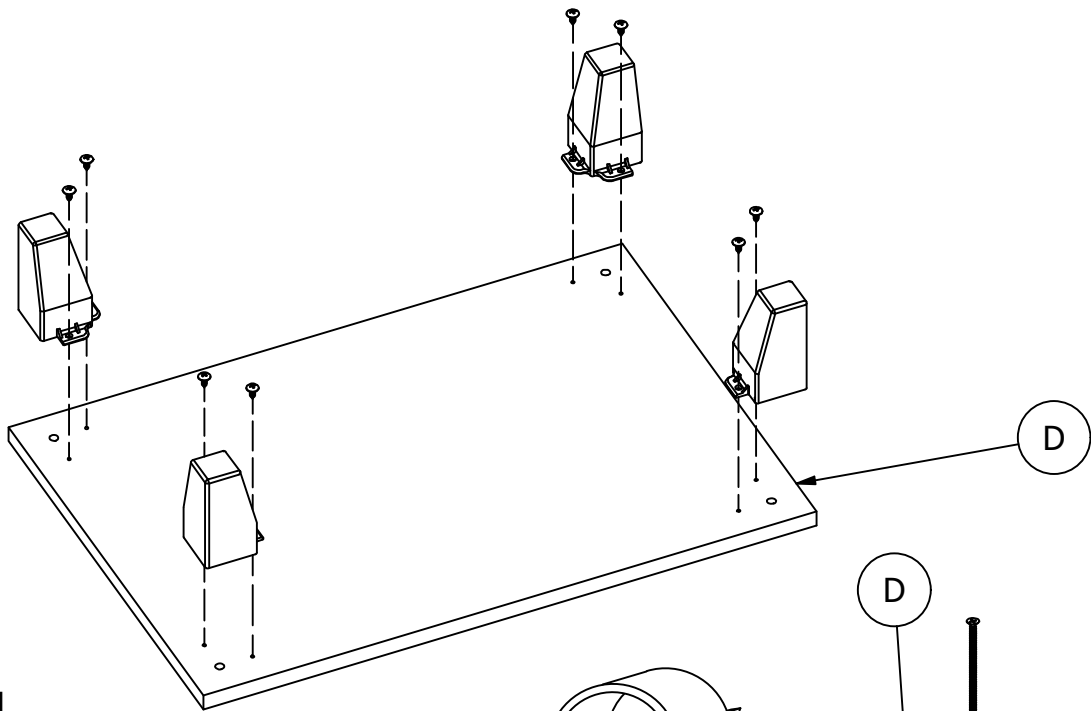

Flip panel over
Voltear el panel
Retournez le panneau

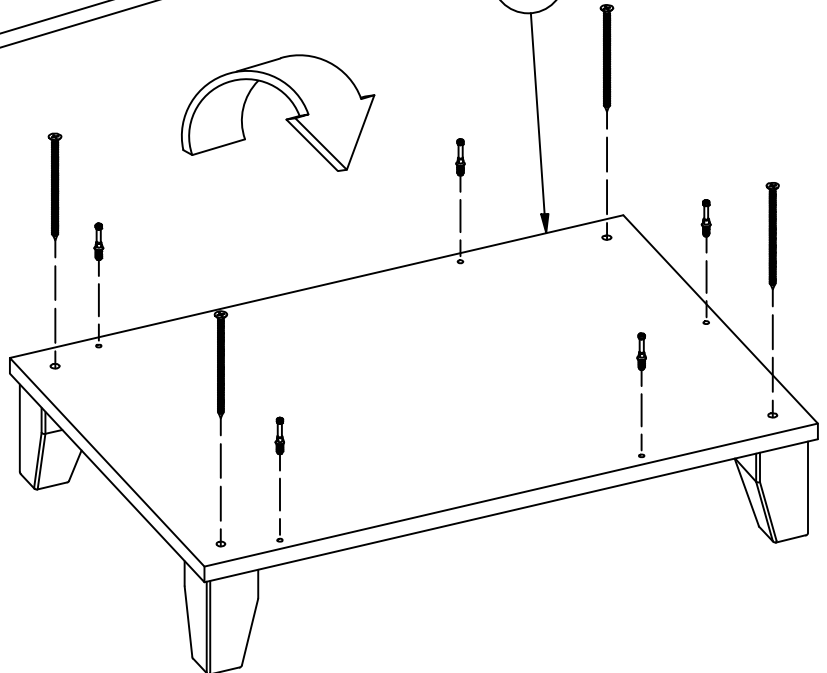
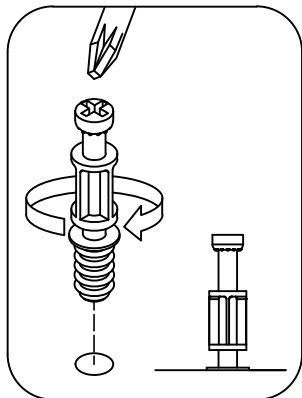

H181468US

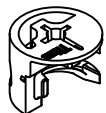

[5]

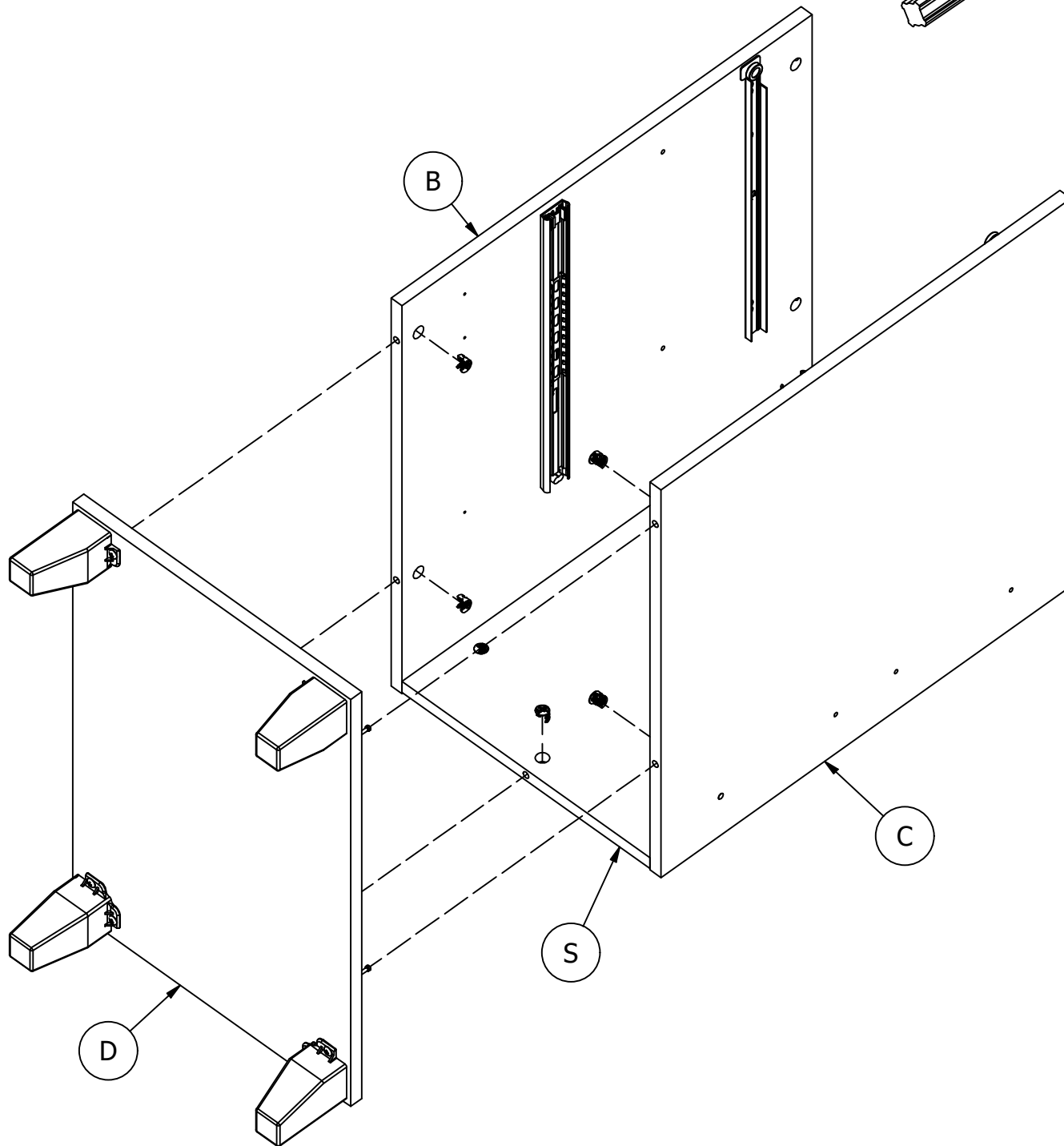
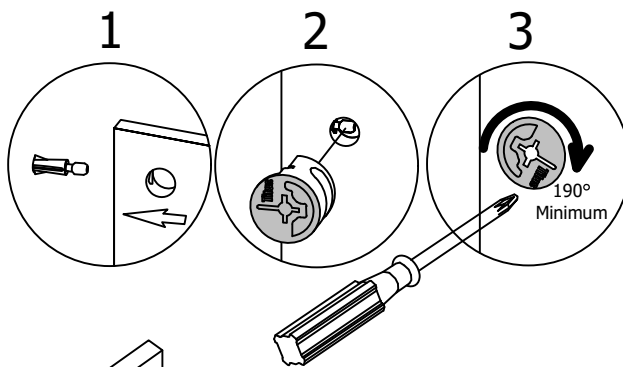

H181468US

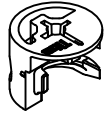

[5]

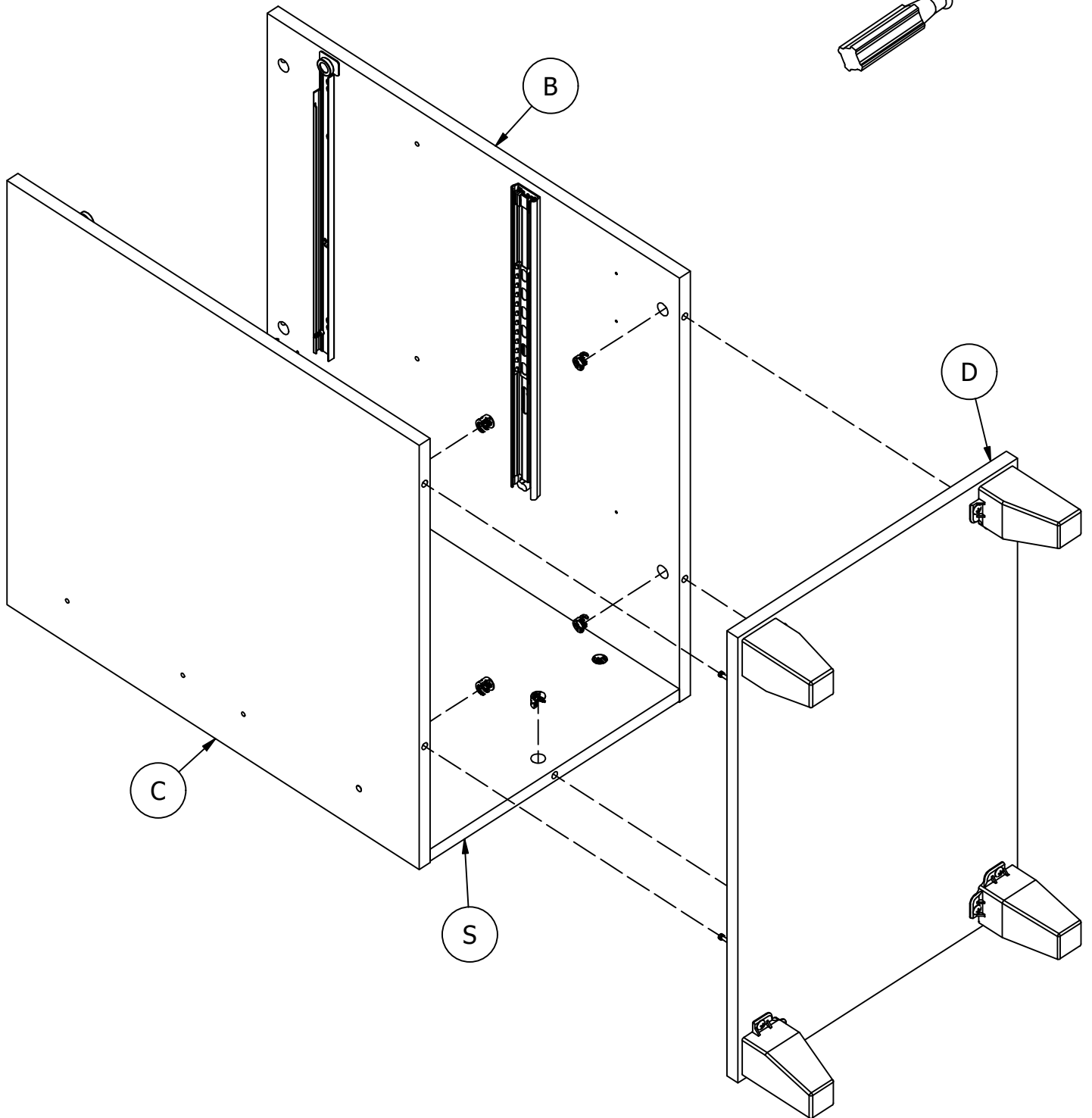
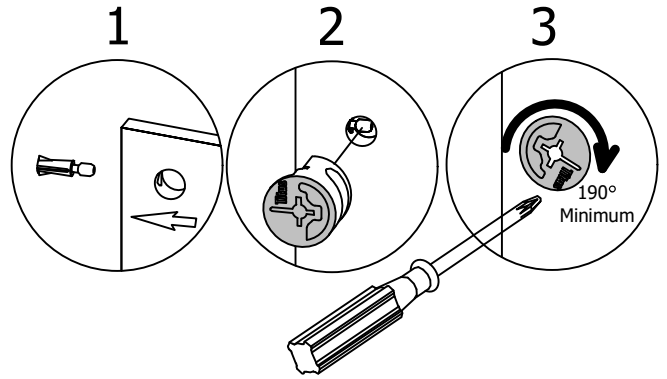

H72988 [4]

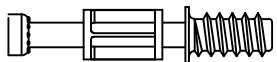

[2]
5mm

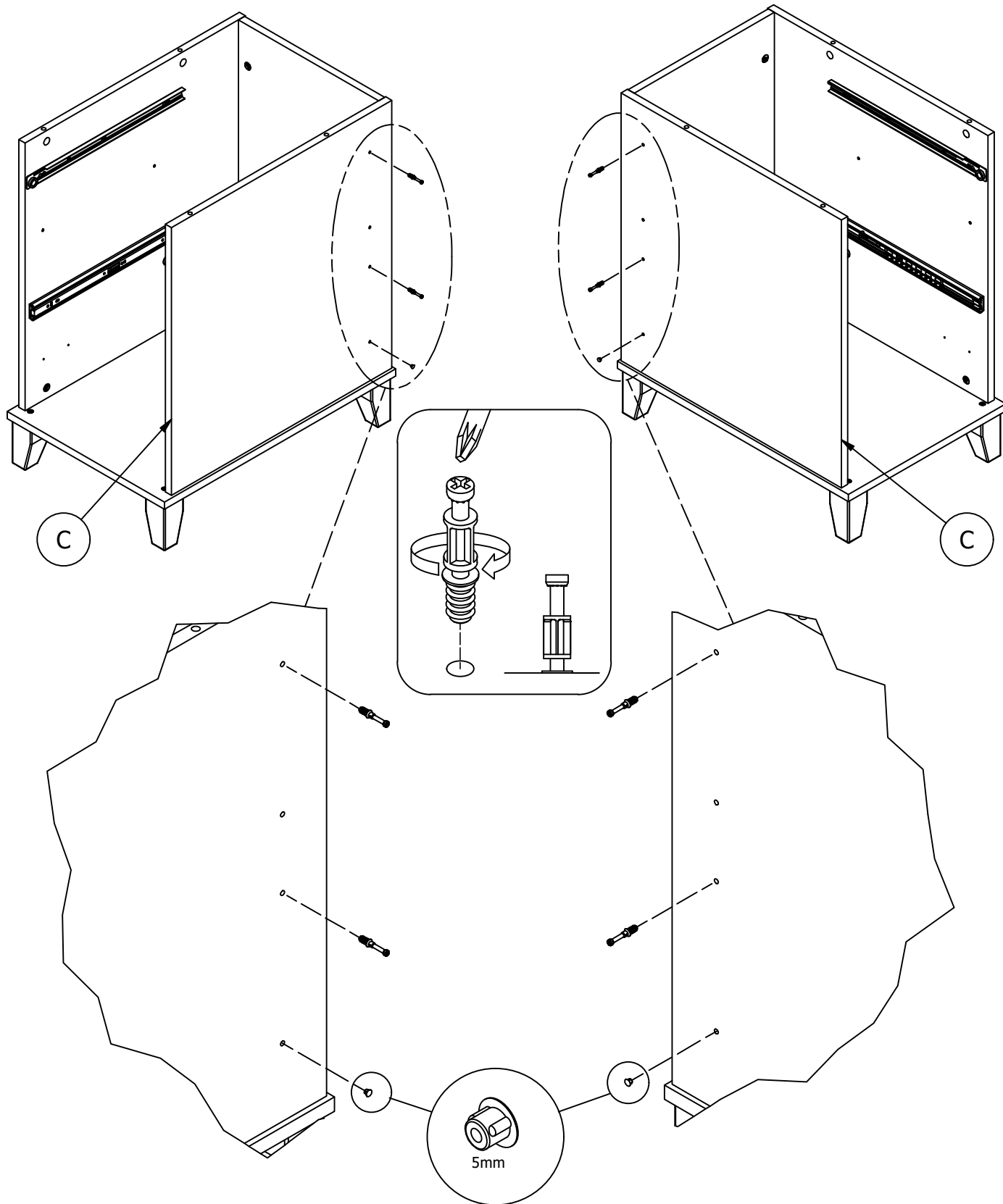

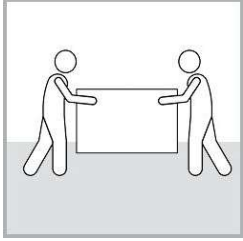

Team Lift
Esfuerzo de equipo
Effort d'équipe

H181468US [4]

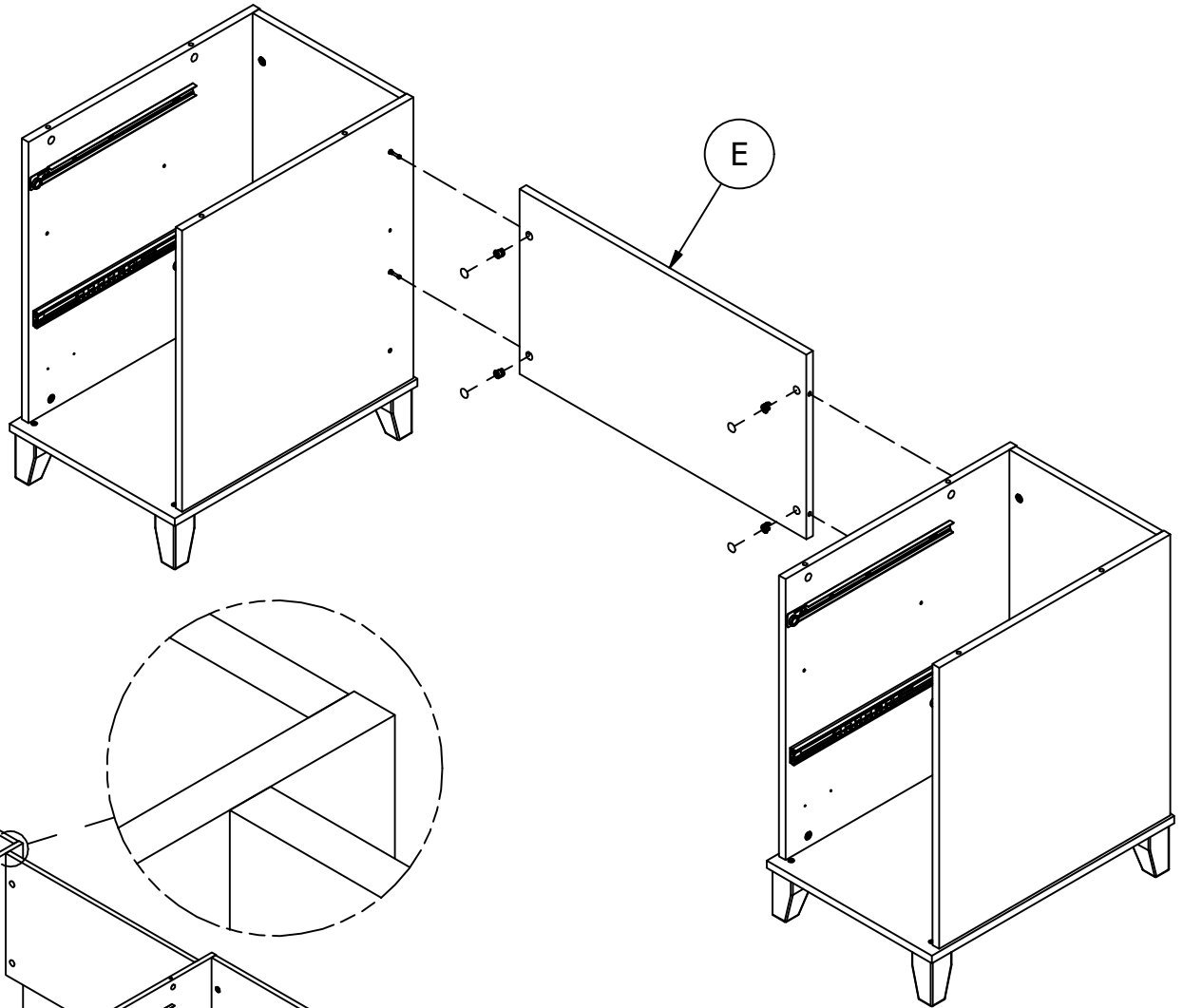
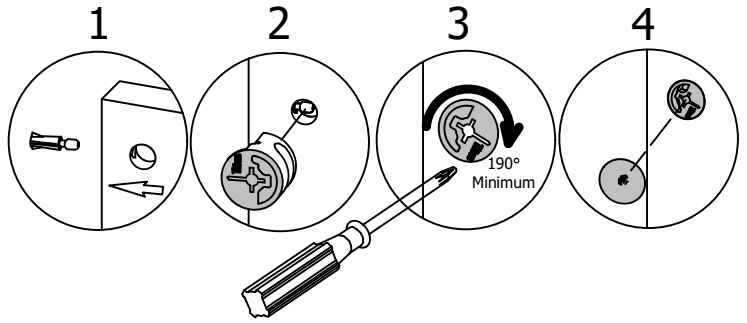
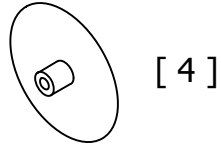

Finished view

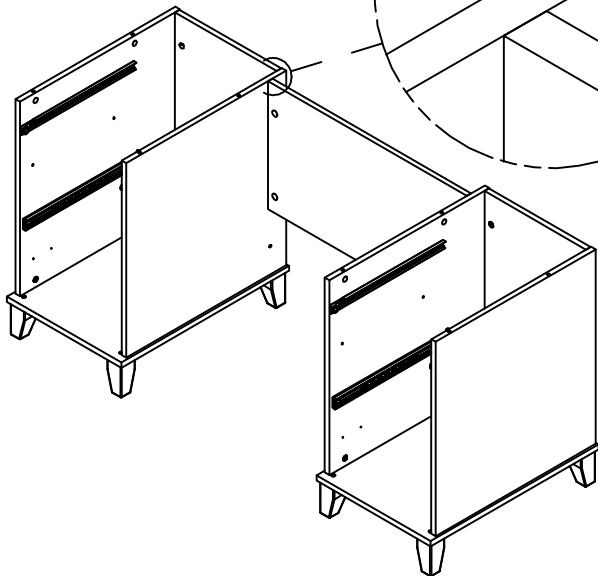

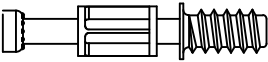
H72988  [8]

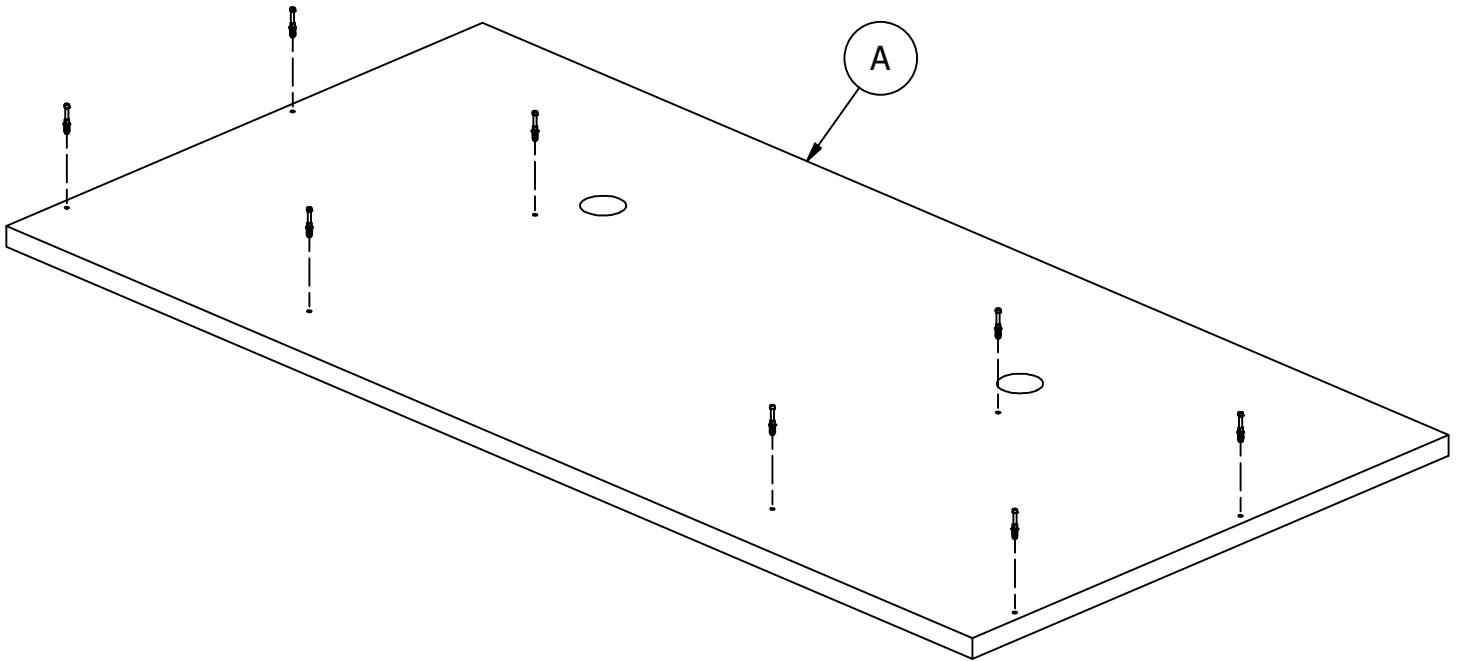
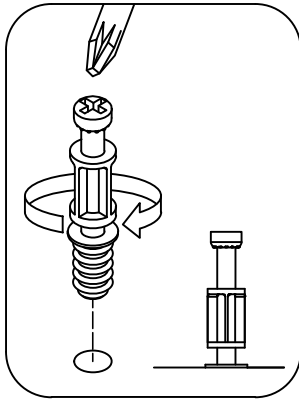

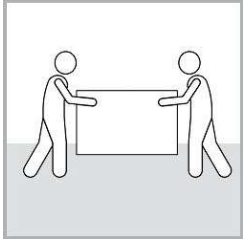

Team Lift
Esfuerzo de equipo
Effort d'équipe

H181468US

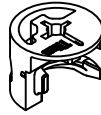

[8]

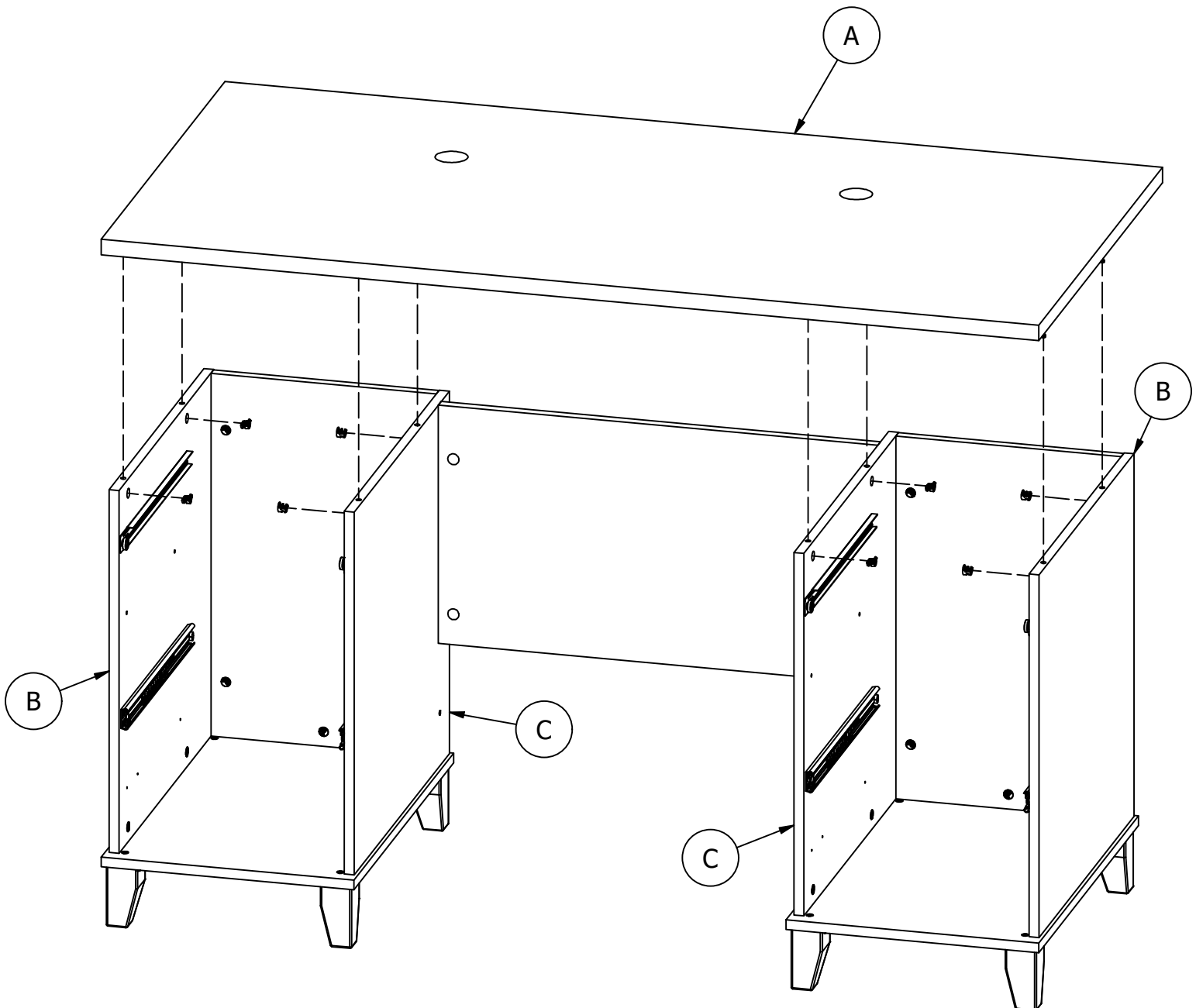
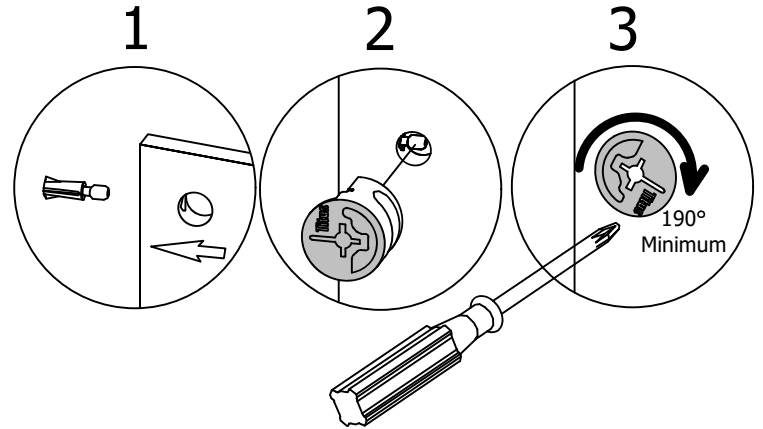

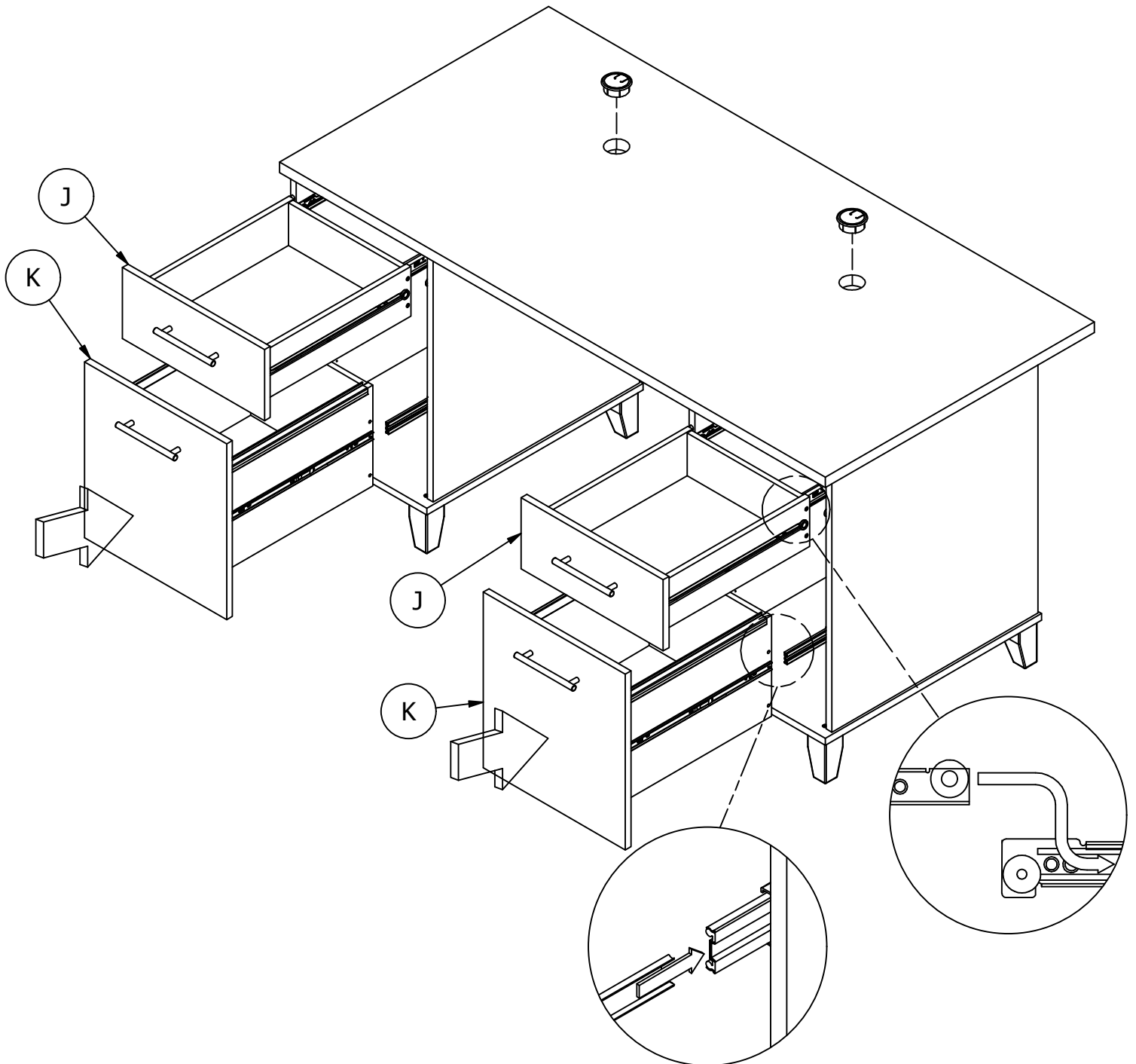
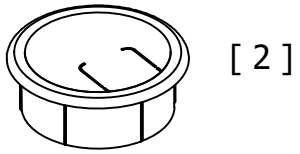

DRAWER FRONT VIEW
VISTA FRONTAL DEL CAJÓN
TIROIRS VUS DE FACE

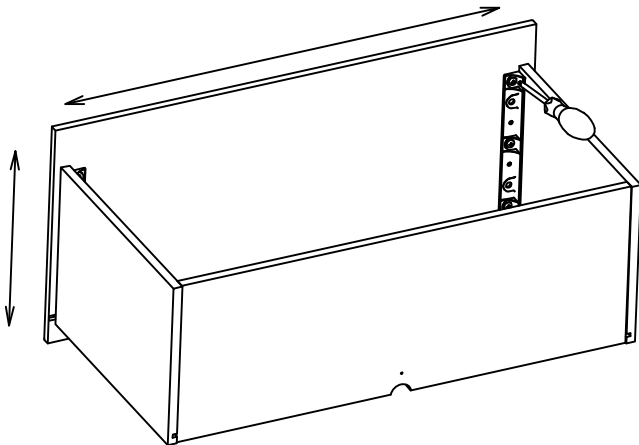
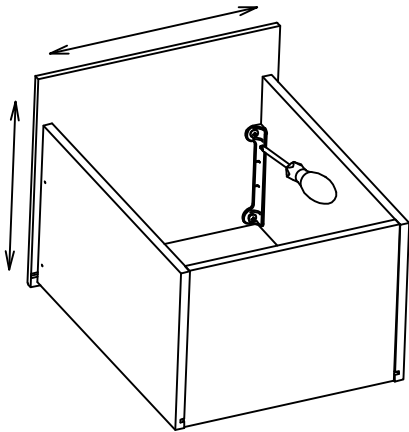
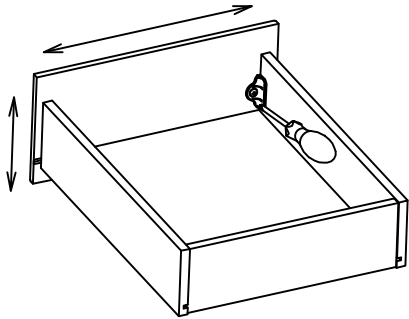
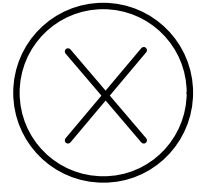
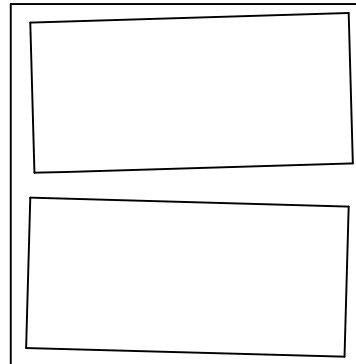
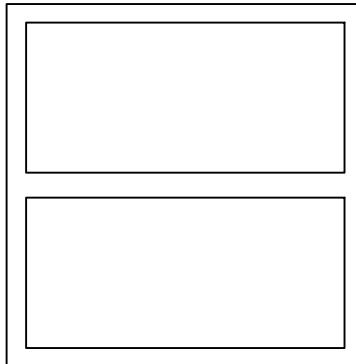

REQUIRED TOOL: PHILLIPS SCREWDRIVER

HERRAMIENTA REQUERIDA: DESTORNILLADOR PHILLIPS
OUTIL REQUIS: TOURNEVIS CRUCIFORME



1. LOOSEN SCREWS.
2. ADJUST DRAWER FRONTS.
3. TIGHTEN SCREWS.

1. Afloje los tornillos
2. Ajustar frentes de cajón
3. Apriete los tornillos

1. Desserrer les vis
2. Ajuster les façades des tiroirs
3. Serrer les vis

Gently clean surfaces with a damp sponge eraser.
Limpie suavemente las superficies con una esponja húmeda.
Nettoyer délicatement les surfaces à l'aide d'une éponge humide.

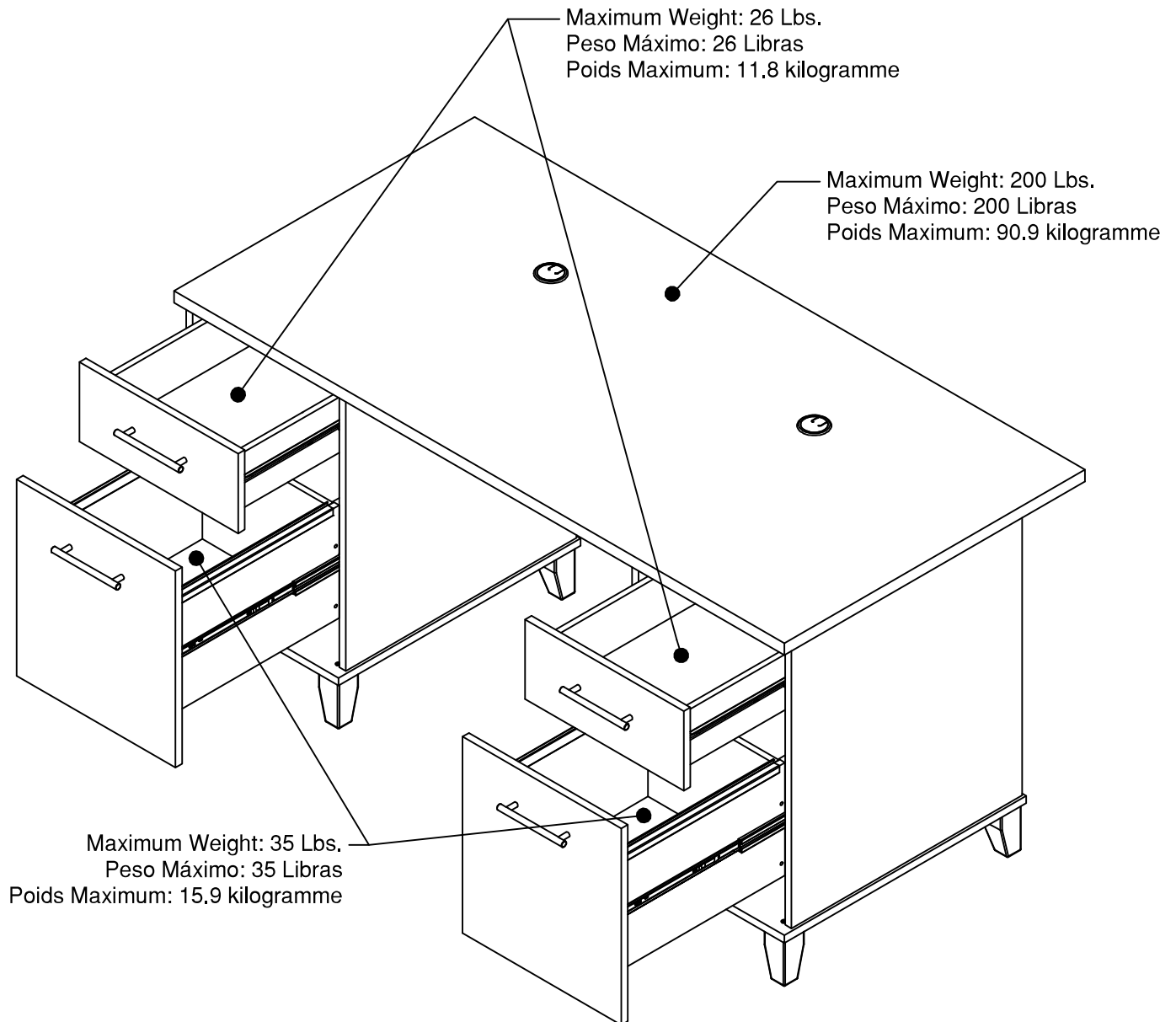

Congratulations! You are all done.
¡Felicidades! Ha finalizado el proceso.
Félicitations! Vous avez terminé.

Parts - Pièces - Piezas

WC81028C		
LABEL	QTY.	NUMBER
A	1	W200551
B	2	W218970
C	2	W218971
D	2	W196080
E	1	W196081
F	2	W218468
G	4	W215261
H	2	W192433
J	2	W218511
K	2	W218512
L	4	W87410
M	4	W106489
S	2	W193878

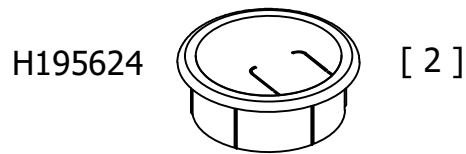
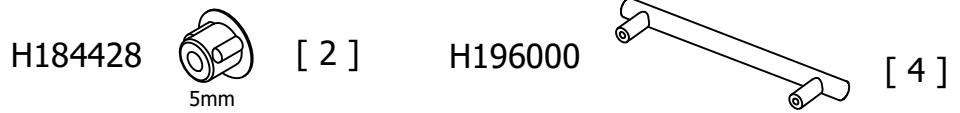
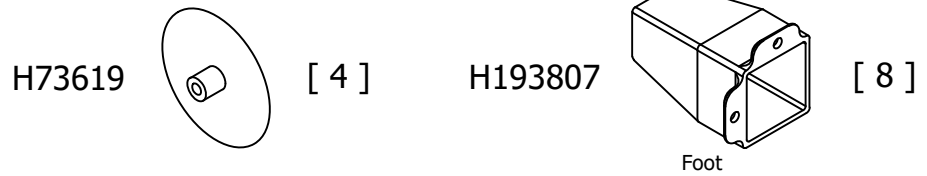

WC81128C		
LABEL	QTY.	NUMBER
A	1	W200489
B	2	W218972
C	2	W218973
D	2	W200492
E	1	W200493
F	2	W218468
G	4	W215261
H	2	W192433
J	2	W218513
K	2	W218514
L	4	W87410
M	4	W106489
S	2	W200494

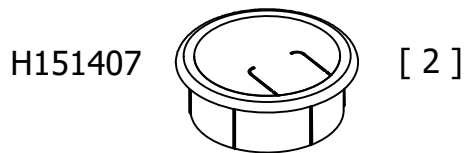
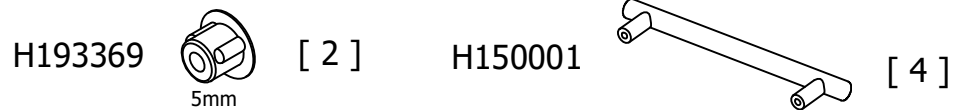
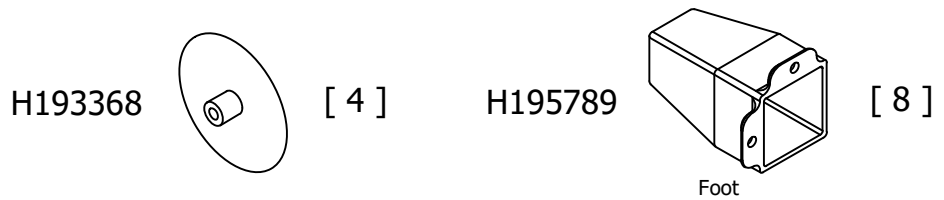

Parts - Pièces - Piezas

WC81228C		
LABEL	QTY.	NUMBER
A	1	W195870
B	2	W218974
C	2	W218975
D	2	W195873
E	1	W195874
F	2	W218468
G	4	W215261
H	2	W192433
J	2	W218515
K	2	W218516
L	4	W87410
M	4	W106489
S	2	W195875

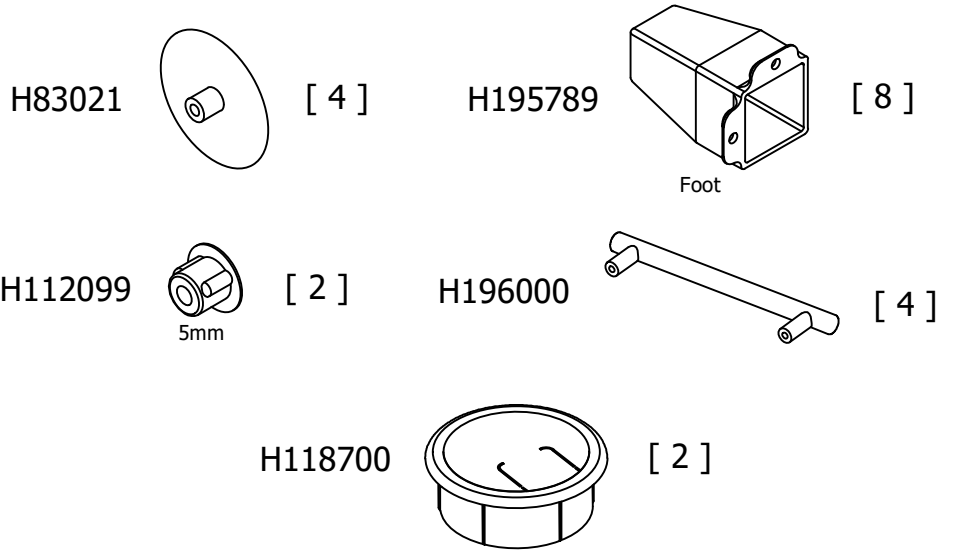

WC81328C		
LABEL	QTY.	NUMBER
A	1	W200395
B	2	W218976
C	2	W218977
D	2	W200398
E	1	W200399
F	2	W218468
G	4	W215261
H	2	W192433
J	2	W218517
K	2	W218518
L	4	W87410
M	4	W106489
S	2	W200400

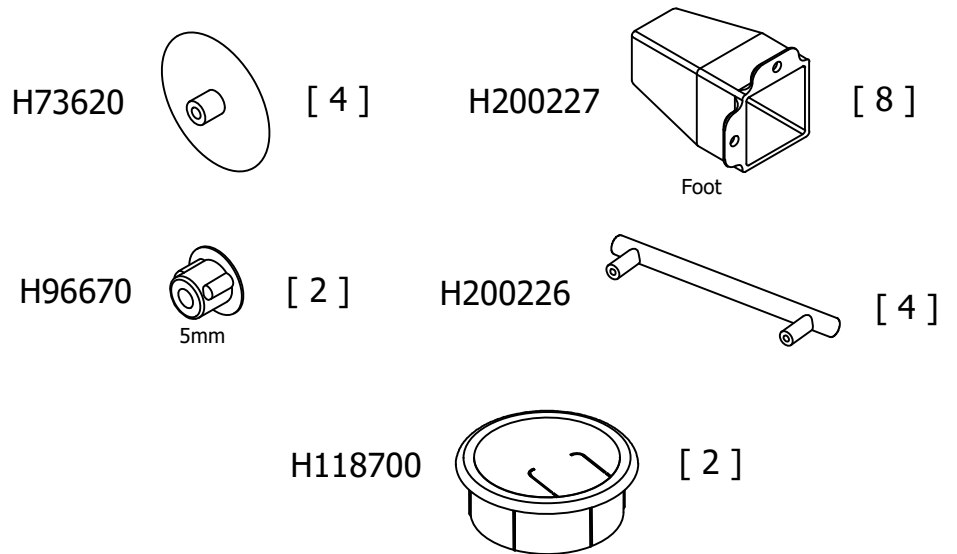

Parts - Pièces - Piezas

WC81428D		
LABEL	QTY.	NUMBER
A	1	W187452
B	2	W218978
C	2	W218979
D	2	W187455
E	1	W187456
F	2	W218468
G	4	W215261
H	2	W192433
J	2	W218519
K	2	W218520
L	4	W87410
M	4	W106489
S	2	W187457

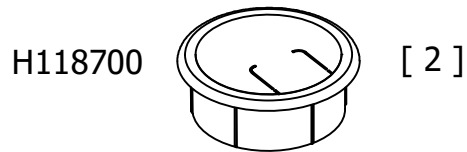
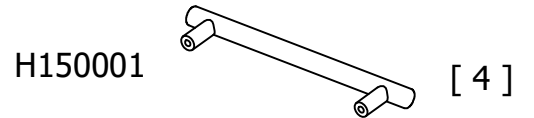
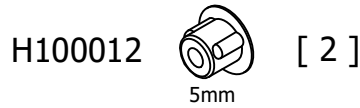
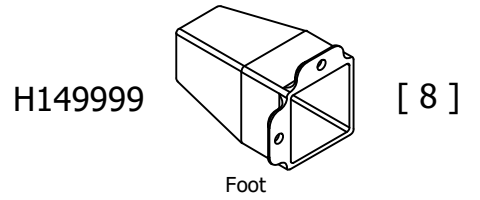
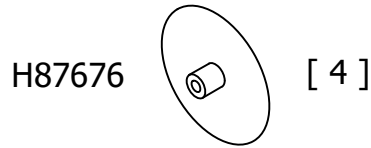

WC81528C		
LABEL	QTY.	NUMBER
A	1	W193873
B	2	W218980
C	2	W218981
D	2	W193876
E	1	W193877
F	2	W218468
G	4	W215261
H	2	W192433
J	2	W218511
K	2	W218512
L	4	W87410
M	4	W106489
S	2	W193878

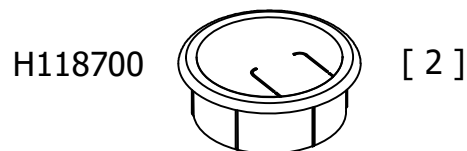
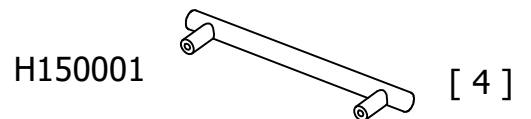
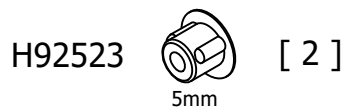
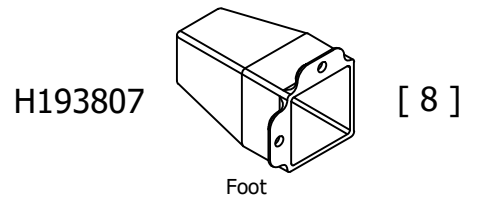
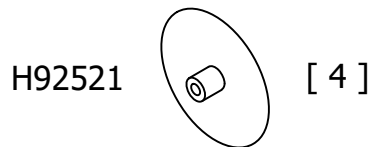

Parts - Pièces - Piezas

WC81628C		
LABEL	QTY.	WC81628
A	1	W186381
B	2	W218982
C	2	W218983
D	2	W186384
E	1	W186385
F	2	W218468
G	4	W215261
H	2	W192433
J	2	W218523
K	2	W218524
L	4	W87410
M	4	W106489
S	2	W187470

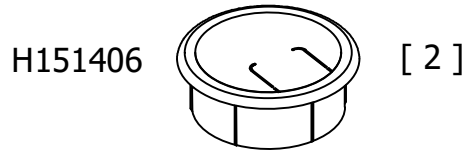
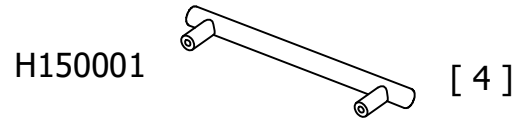
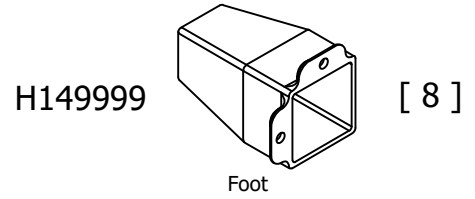
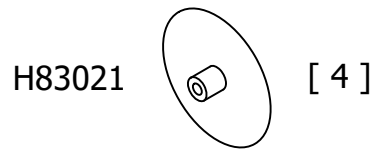

WC81728D		
LABEL	QTY.	WC81728
A	1	W187458
B	2	W218984
C	2	W218985
D	2	W187461
E	1	W187462
F	2	W218468
G	4	W215261
H	2	W192433
J	2	W218525
K	2	W218526
L	4	W87410
M	4	W106489
S	2	W187463

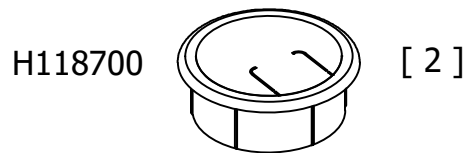
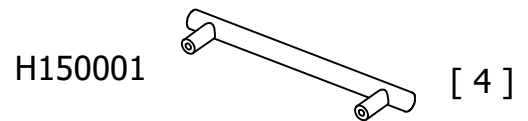
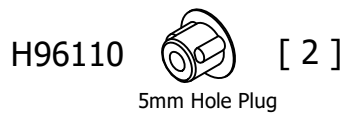
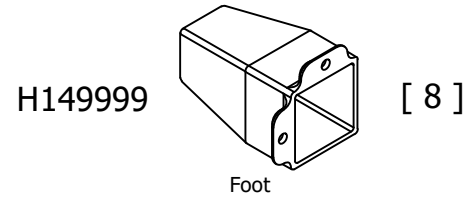
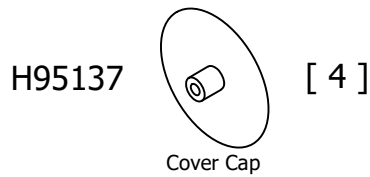

Parts - Pièces - Piezas

WC81828D		
LABEL	QTY.	NUMBER
A	1	W187464
B	2	W218986
C	2	W218987
D	2	W187467
E	1	W187468
F	2	W218468
G	4	W215261
H	2	W192433
J	2	W218527
K	2	W218528
L	4	W87410
M	4	W106489
S	2	W187469

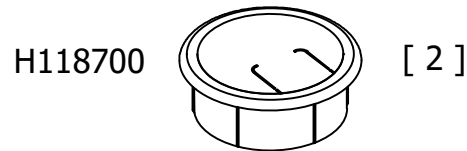
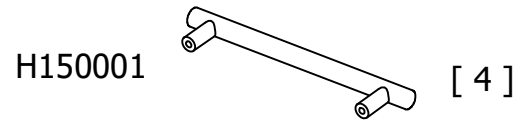
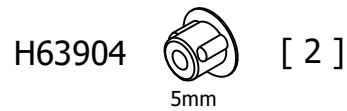
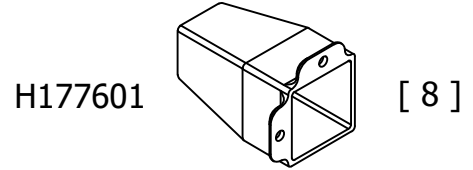
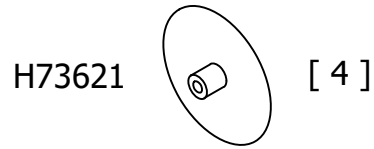

WC81928C		
LABEL	QTY.	NUMBER
A	1	W196077
B	2	W218970
C	2	W218971
D	2	W196080
E	1	W196081
F	2	W218468
G	4	W215261
H	2	W192433
J	2	W218529
K	2	W218530
L	4	W87410
M	4	W106489
S	2	W196082

