

# Potting Bench

**Required Tools:** #2 Philips or Robertson driver, tape measure, pencil.

Before assembly, please check package contents to verify all parts are accounted for.

## Package Contents:

- (A) Hutch Profile... 1
- (B) Shelf Brace... 1
- (C) Shelf... 2
- (D) Top Apron... 2
- (E) Top Slat... 9
- (F) Backstop... 1
- (G) Legs... 4
- (H) Bottom Apron... 2
- (I) Bottom Slat... 7
- (J) Wings... 2
- (K) Hutch Side... 2
- (L) Bottom Cleat... 2
- (M) Top Cleat... 2

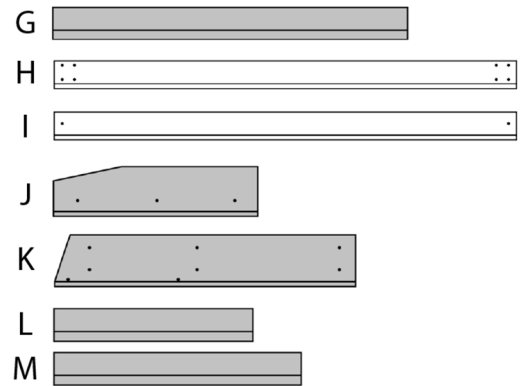
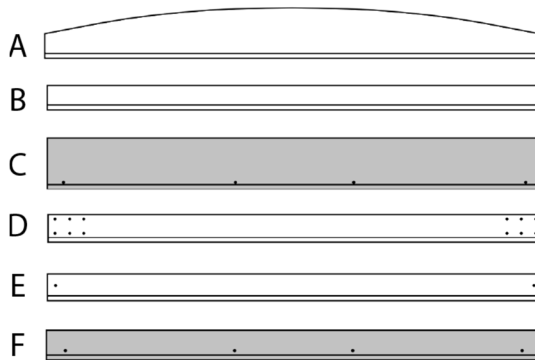

## Hardware:

- Logo with nails
- 1- $\frac{3}{4}$  inch Screw...106
- Spacer Blocks... 2

## STEP 1. Build Top Table

- Place Top Cleats (M) between ends of Top Aprons (D), attach with screws.
- Set Top Slats (E) across top cleats, tight together, attach with screws.
- Set Backstop (F) on the lip at back of table top, attach with

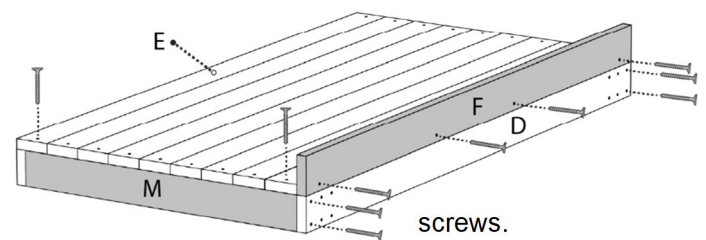

## STEP 2. Build Bottom Table

- Place Bottom Cleats (L) between ends of Bottom Aprons (H), attach with screws.
- Set Bottom Slats (I) across bottom cleats, use spacer blocks to create uniform spacing between slats, attach with screws.

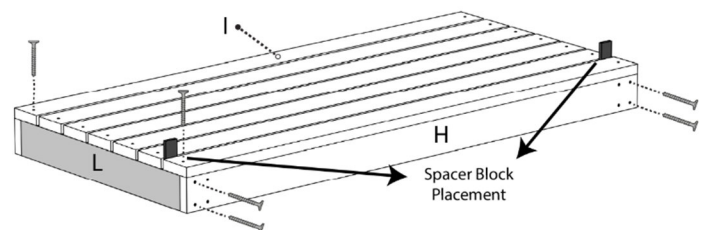

### STEP 3. Build Bench

- Set table top on end, place Legs (G) inside corners, attach to top aprons with screws.
- Flip table top, attach remaining legs.
- Make a pencil mark 4-inches from bottom, on inside of legs.  
*TIP: These marks set the bottom table height. This can be adjusted to your preference.*
- Insert bottom table between legs, align with marks on legs, attach with screws.

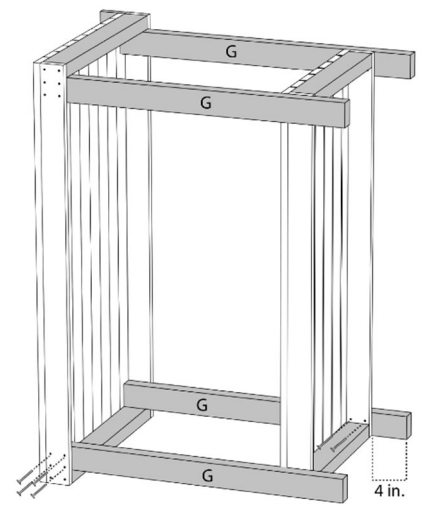

### STEP 4. Build Hutch

- Set Shelf (C) on edge, holes at bottom, beside Hutch Profile (A), attach with screws
- Set 2<sup>nd</sup> Shelf (C) on edge beside Shelf Brace (B), attach with screws.
- Align hutch profile/shelf with top holes on Hutch Sides (K), attach with screws.
- Align hutch brace/shelf with middle holes on hutch sides, attach with screws.

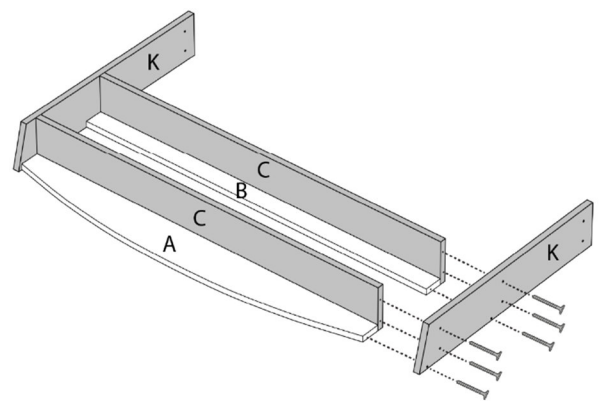

### STEP 5. Final Assembly

- Set bench on back. Flush bottom of hutch with bottom of table top, attach with screws.
- Attach Bench Wing (M) to ends of Bench with screws.
- Attach Logo with nails, to location of your choosing.

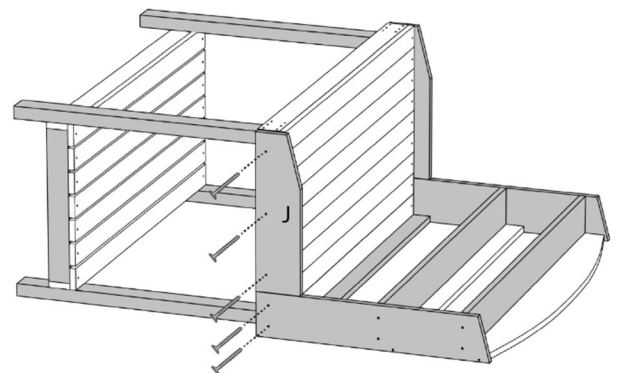

Your new Potting Bench is ready for use.

#### SAFETY NOTICE:

For your safety do not stand or climb on any part of this Potting Bench. Periodically throughout the year inspect all components and tighten hardware as needed.