





















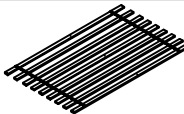

# ASSEMBLY INSTRUCTION

Thank you for purchasing this quality product. Be sure to check all packing material carefully for small parts which may have come loose inside the carton during shipment. Separate, identify and count all parts and metal hardware. Compare with parts list to be sure all parts are present. If any part (S) are missing or damaged, please contact your local furniture dealer. For efficient and speedy service, please indicate the model number and code letter of parts (S) when needed.

**Do not fully tighten screws until fully assembled**

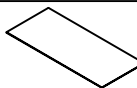
HARDWARE LIST				
No	Description	Sketch	Size	Qty
A	Allen Bolt		5/16"X35mm	12pcs
B	Allen Bolt		5/16"X55mm	10pcs
C	Lock Washer		5/16"	22pcs
D	Flat Washer		5/16"X19X2mm	22pcs
E	Allen Key		4mm	1 pc
F	Cotter Nut		1/4"X35mm	10sets
G	Holder		170X18X15mm	2 pcs
H	Hax-Headbolts		5/32"X20mm	4 pcs
I	Screw		#8X25mm	34pcs
J	Screw		#8X12mm	2

No.	Description	Sketch	Qty
1	Headboard Panel		1 pc
2	Footboard		1 pc
3	Headboard Post		2 pcs
4	Side Rails		2 pcs
5	Headboard bottom stretcher		1 pc
6	Slat Roll		1 Set
7	Support Leg		5 pcs
8	Drawer box		1 pc
9	Drawer Front Panel		2 pcs
10	Drawer Side Panel	 L/R	4 pcs
11	Drawer Back Panel		2 pcs
12	Drawer Bottom Panel		2 pcs
13	Drawer Bottom Support		2 pcs
14	Box Support Leg		2 pcs

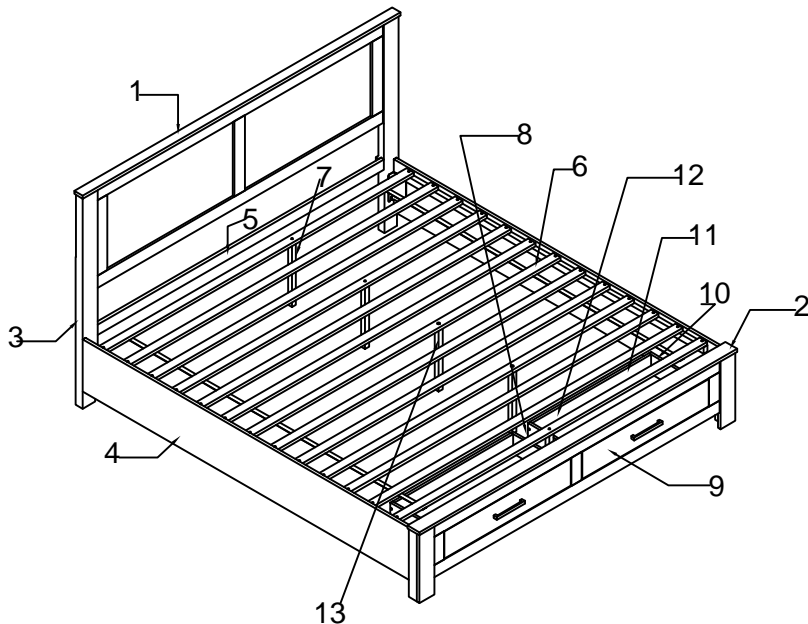

# ASSEMBLY INSTRUCTION

Thank you for purchasing this quality product. Be sure to check all packing material carefully for small parts which may have come loose inside the carton during shipment. Separate, identify and count all parts and metal hardware. Compare with parts list to be sure all parts are present. If any part (S) are missing or damaged, please contact your local furniture dealer. For efficient and speedy service, please indicate the model number and code letter of parts (s) when needed.

**Do not fully tighten screws until fully assembled**

## STEP 1

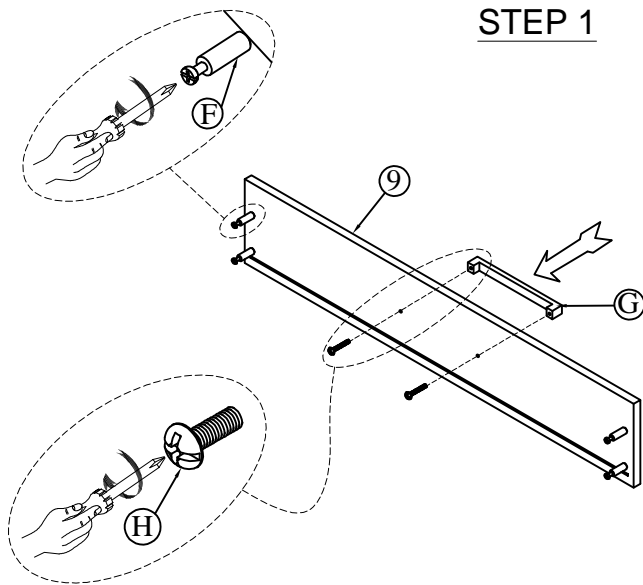

## STEP 2

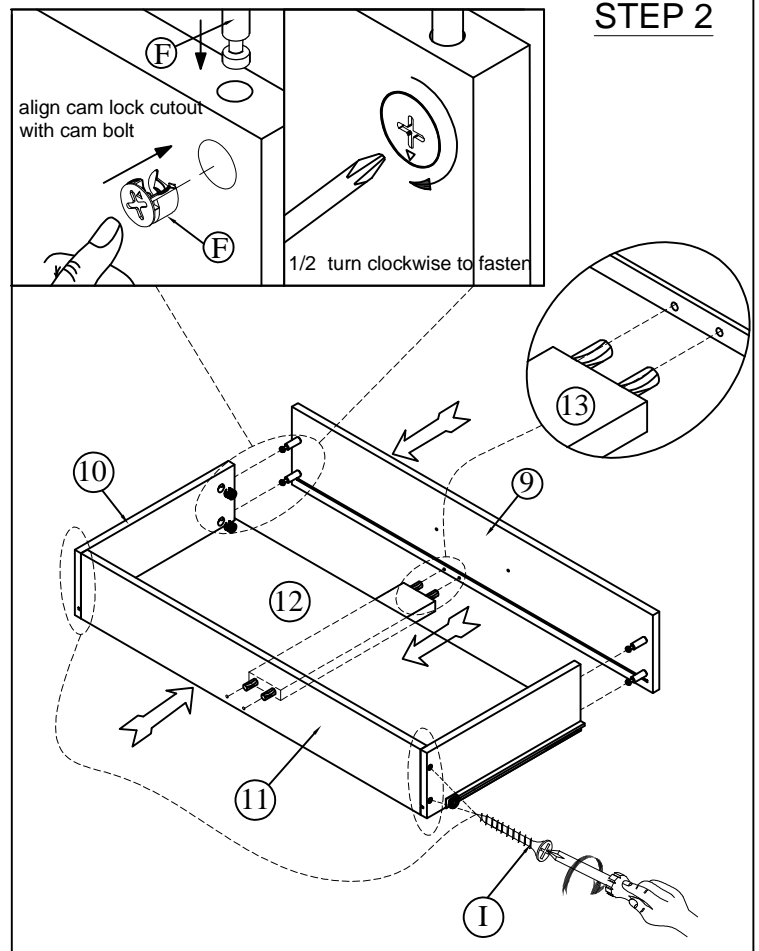

Completed Drawer

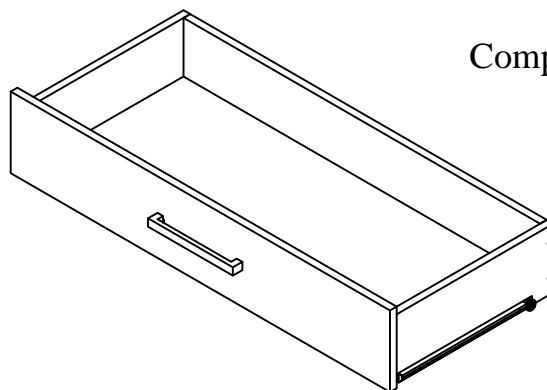

# ASSEMBLY INSTRUCTION

Thank you for purchasing this quality product. Be sure to check all packing material carefully for small parts which may have come loose inside the carton during shipment. Separate, identify and count all parts and metal hardware. Compare with parts list to be sure all parts are present. If any part (S) are missing or damaged, please contact your local furniture dealer. For efficient and speedy service, please indicate the model number and code letter of parts (S) when needed.

**Do not fully tighten screws until fully assembled**

## STEP 3

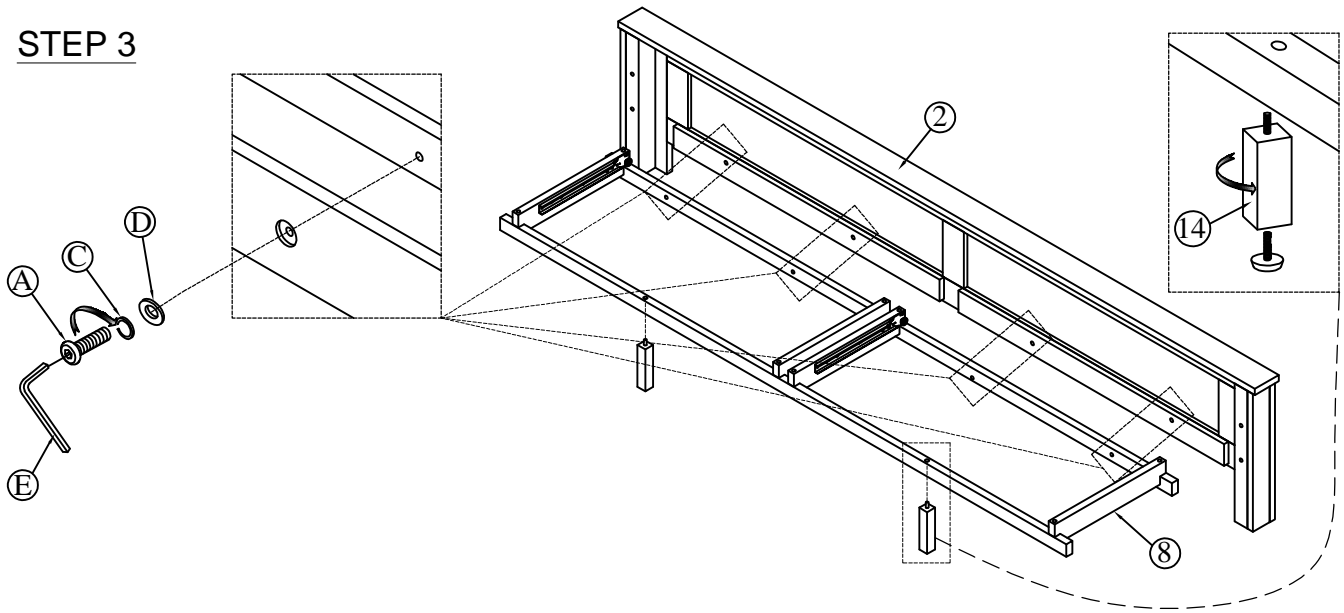

## STEP 4

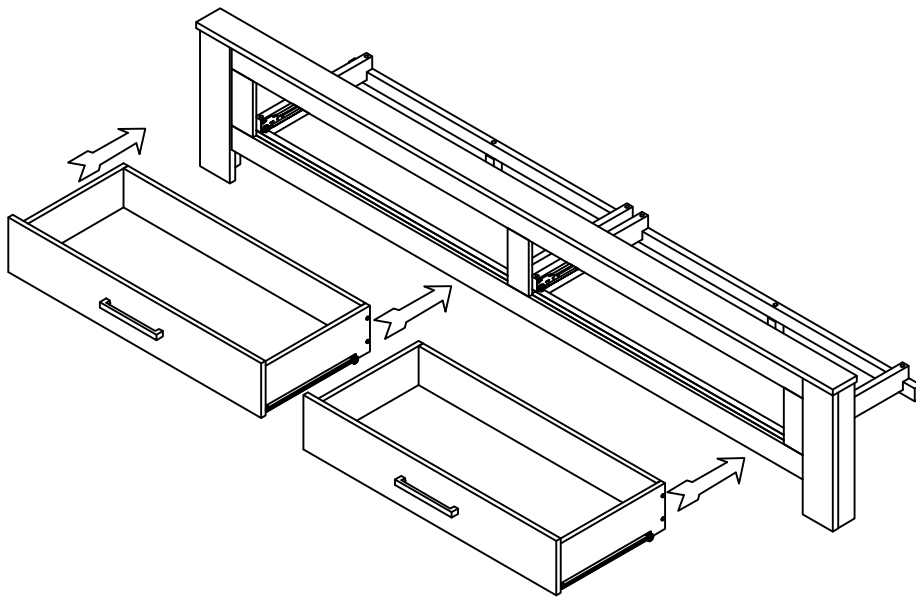

# ASSEMBLY INSTRUCTION

Thank you for purchasing this quality product. Be sure to check all packing material carefully for small parts which may have come loose inside the carton during shipment. Separate, identify and count all parts and metal hardware. Compare with parts list to be sure all parts are present. If any part (S) are missing or damaged, please contact your local furniture dealer. For efficient and speedy service, please indicate the model number and code letter of parts (S) when needed.

**Do not fully tighten screws until fully assembled**

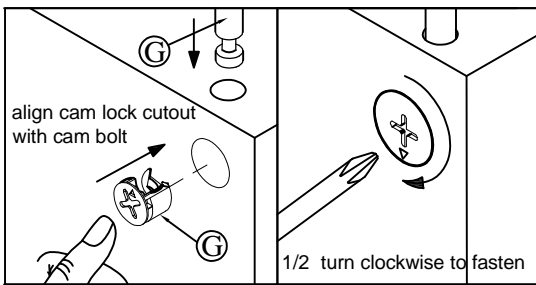

## STEP 5

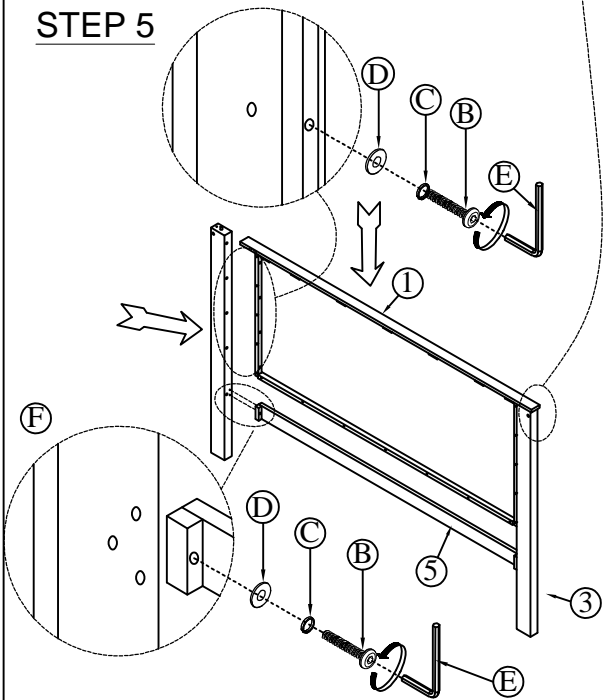

## STEP 6

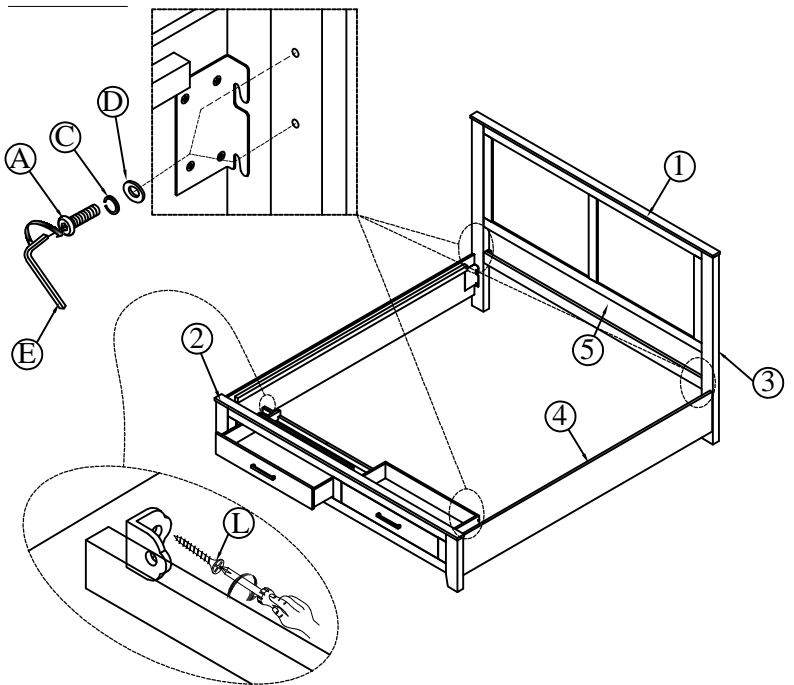

## STEP 7

