











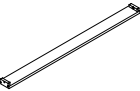

ASSEMBLY INSTRUCTION

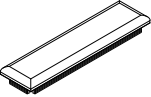
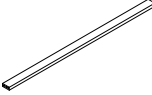
ITEM NO: FSH2550 CONSOLE TABLE AND BENCH

Thank you for purchasing this quality product. Be sure to check all packing material carefully for small parts which may have come loose inside the carton during shipment. Separate, identify and count all parts and metal hardware. Compare with parts list to be sure all parts are present. If any part(s) are missing or damaged, please contact your local furniture dealer. For efficient and speedy service, please indicate the model number and code letter of part(s) needed.

*** Do not fully tighten bolts until fully assembled ***

No.	COMPONENT LIST		Q'ty	No.	COMPONENT LIST		Q'ty
(A)		TABLE TOP	1pc	(E)		BENCH LEGS FRONT LEFT BACK RIGHT	2pcs
(B)		TABLE LEGS	2pcs	(F)		BENCH LEGS FRONT RIGHT BACK LEFT	2pcs
(C)		TABLE CROSS BAR	1pc	(G)		STRETCHER	2pcs
(D)		BENCH FRAME WITH CUSHION	1pc	(H)		BENCH CROSS BAR	1pc
No.	HARDWARE LIST		Q'ty	No.	HARDWARE LIST		Q'ty
1		Bolts 5/16x2"	20pcs	4		Dowel Wood	8pcs
2		Lock Washer 5/16"	20pcs	5		Screws 4 x 1.5"	4pcs
3		Flat Washer 5/16"	20pcs	6		Allen key K4	1pc

Step 1: Align and place Leg (B) into Table Top (A) and Cross Bar (C). After use Dowel wood (4) positioning Cross bar (C). Then use Bolt (1), Lock washer, Flat washer (3) and Allen key (6) fully tighten all bolt.

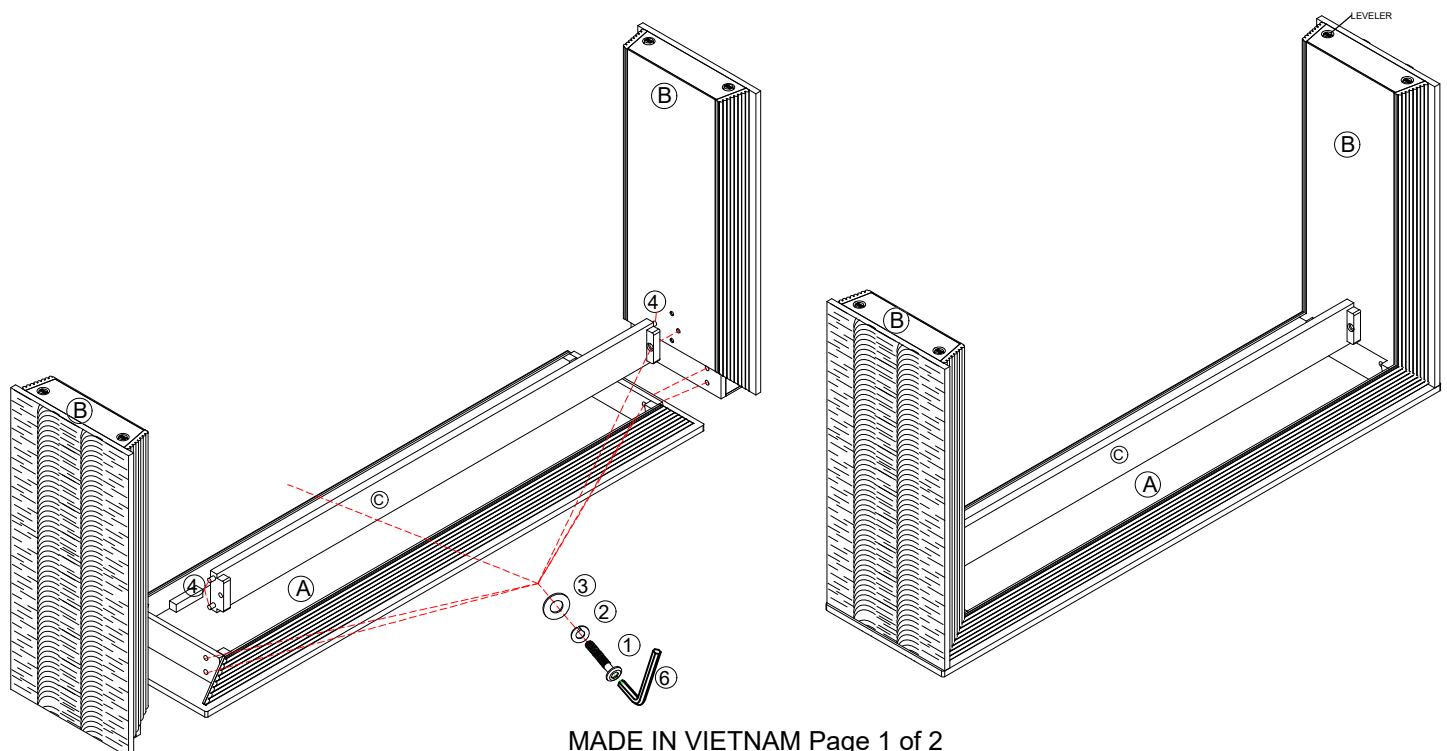

ASSEMBLY INSTRUCTION

ITEM NO: FSH2550 CONSOLE TABLE AND BENCH

Thank you for purchasing this quality product. Be sure to check all packing material carefully for small parts which may have come loose inside the carton during shipment. Separate, identify and count all parts and metal hardware. Compare with parts list to be sure all parts are present. If any part(s) are missing or damaged, please contact your local furniture dealer. For efficient and speedy service, please indicate the model number and code letter of part(s) needed.

***** Do not fully tighten bolts until fully assembled *****

Step 2: Align and place Leg (E),(F) into Table Stretcher (G) and connect with Cross Bar (H) use Dowel wood (4) positioning. Then use Bolt (1), Lock washer, Flat washer (3) do not fully tighten all bolt.

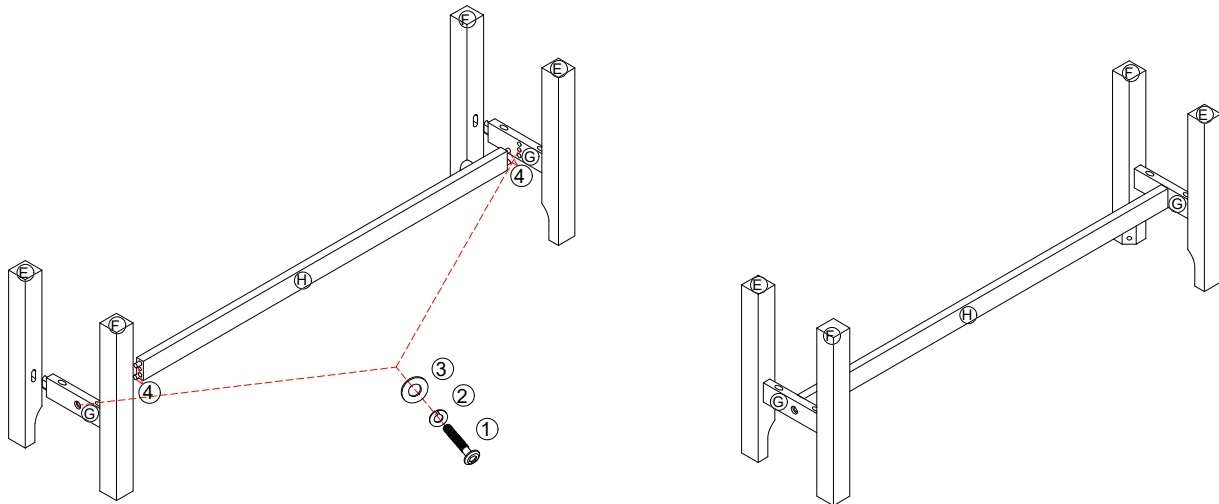

Step 3: Align and place Frame assembled into bench with cushion frame(D). Then use Bolt (1), Lock washer, Flat washer (3), Allen key (6) fully tighten all bolt. And use Screw (5) connect stretcher (G) with leg (E),(F).

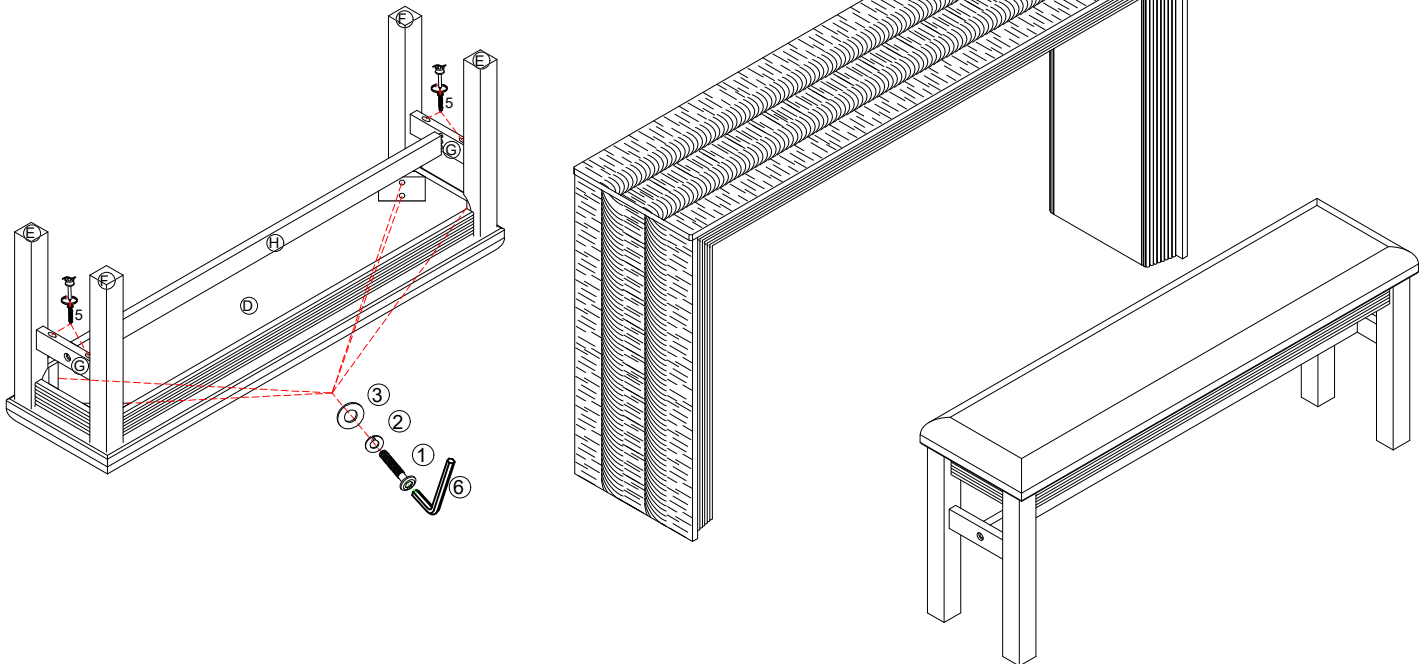

**FINISH .
THANK YOU !**