

HEADBOARD

ASSEMBLY INSTRUCTIONS

Before assembling your headboard, please read through these instructions carefully and familiarize yourself with the different parts.



PARTS LIST

- ① LEFT POST 1 PC
- ② RIGHT POST 1 PC
- ③ TOP / BOTTOM RAIL 2 PCS
- ④ HEADBOARD PANEL 1 PC
- ⑤ SPACER BLOCK 2 PCS

Instructions apply for bed sizes
TWIN > FULL

HARDWARE

- Ⓐ Wood dowel 10 X 30mm - 4 pcs
Spare - 1pc
- Ⓑ JCB M6 X 70mm - 4 pcs
Spare - 1 pc
- Ⓒ Barrel Nut M6 - 4 pcs
- Ⓓ JCB M6 X 40mm - 2 pcs
Spare - 1 pc
- Ⓔ Wood button - 4 pcs
Spare - 1pc
- Ⓕ Allen wrench M4 - 1pc
Spare - 1pc

HARDWARE FOR METAL BED FRAME

- Ⓖ JCB M6 X 25mm (1") - 4 pcs
Spare - 1 pc
- Ⓗ Flat washer - 4 pcs
Spare - 1 pc
- Ⓘ Split washer - 4 pcs
Spare - 1 pc

NOTE: WE INCLUDE SPARE HARDWARE IN CASE DAMAGE OCCURS DURING ASSEMBLY.

Step 1

Attach spacer block (5) to left and right post (1)(2), using wood dowel (A) and JCB (D). Tighten with the Allen wrench (F).

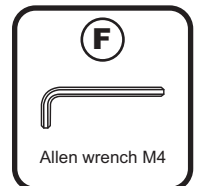
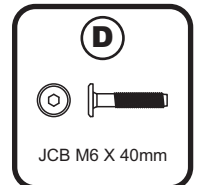
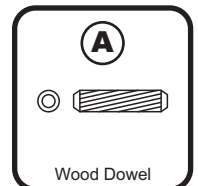
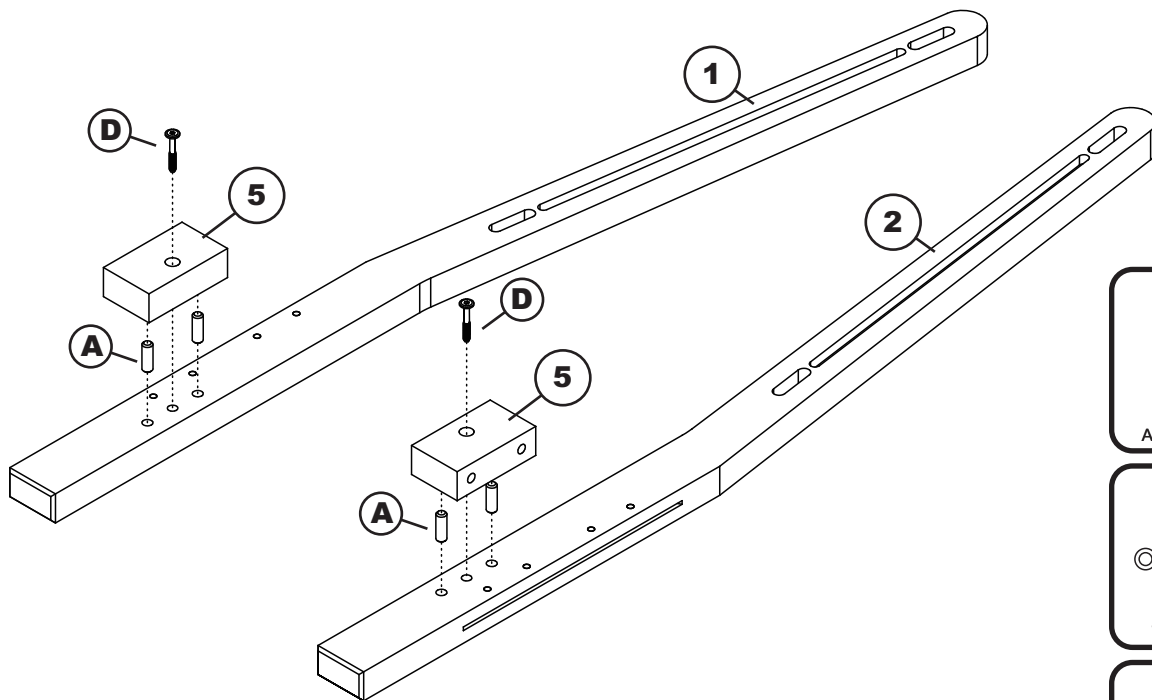

TWIN > FULL

Step 2

Attach top / bottom rail (3) to the right post (2) as shown below. Using JCB (B) and barrel nut (C) tighten with Allen wrench (F). Guide the headboard panel (4) in carefully so that it won't jump out of its grooves. Be sure it fits fully into its groove at the post before fitting the left post (1).

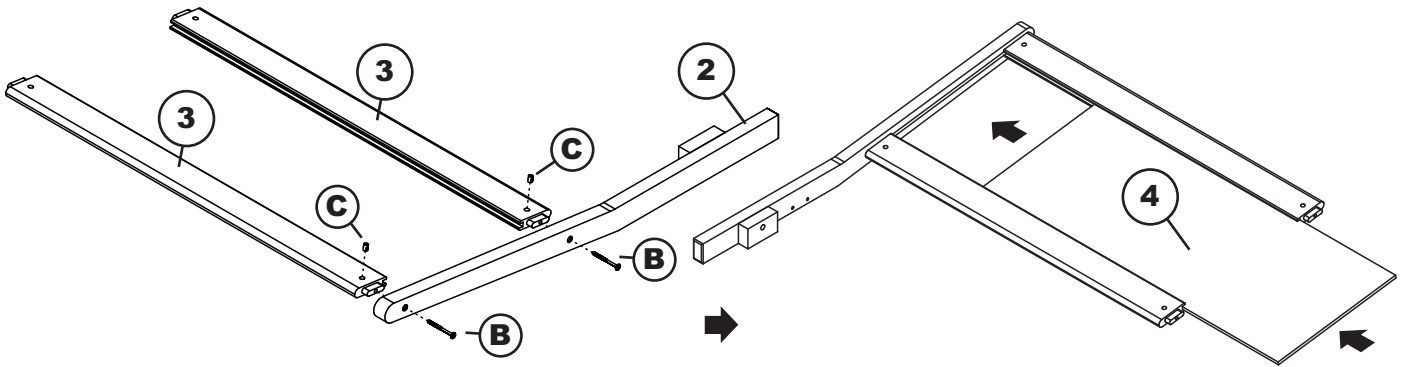

Step 3

Attach left post (1) to the headboard assemble as shown below. Using JCB (B) and barrel nut (C) tighten with Allen wrench (F).

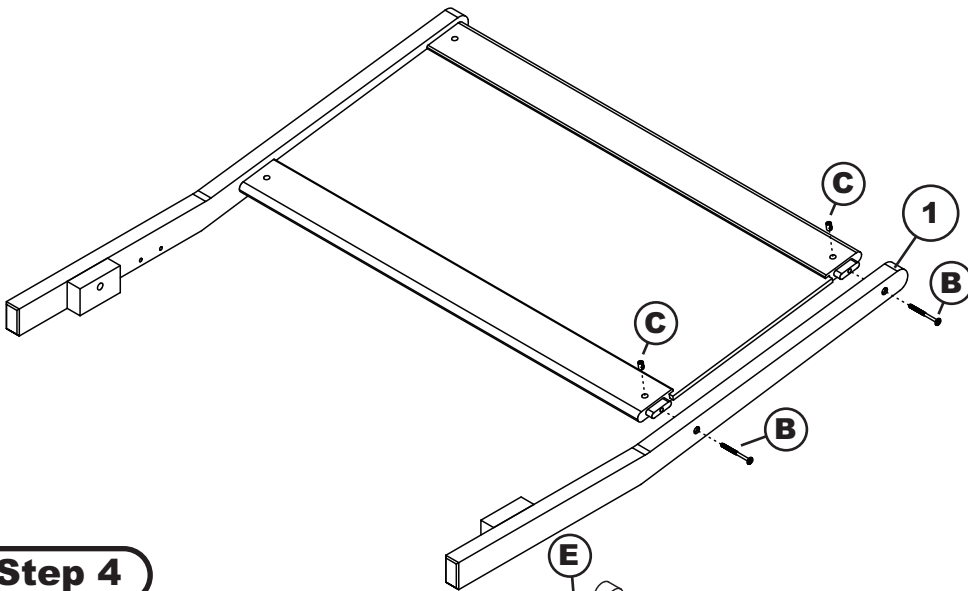

Step 4

Lastly, cover holes with wood button (E).

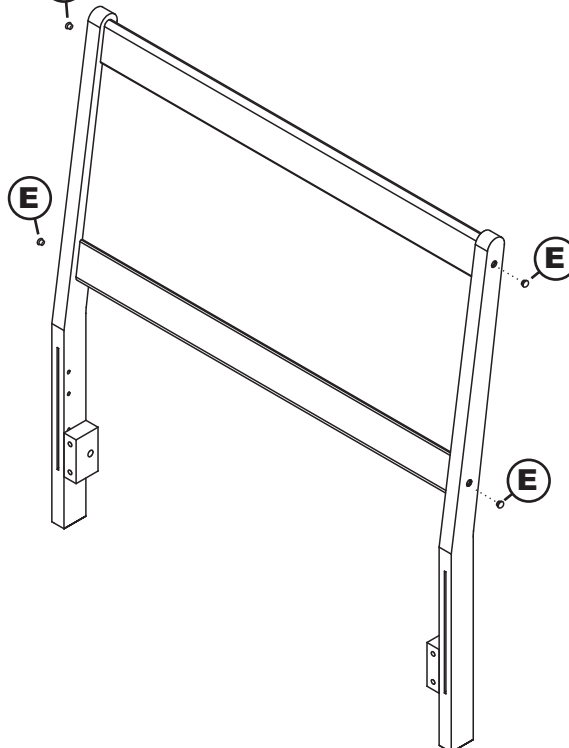

Adult assembly

B



JCB M6 X 70mm

C



Barrel Nut

E



Wood button

F



Allen wrench M4

If you purchased a wood headboard to attach to metal bed frame, please refer to page 3.

ATTACHING HEADBOARD TO METAL BED FRAME

ASSEMBLY INSTRUCTIONS

Before assembling your bed, please read through these instructions carefully and familiarize yourself with the different parts.

Instructions apply for bed sizes
TWIN > FULL > QUEEN > KING



Adult assembly

Metal bed frames are sold separately from wood headboards. The hardware shown on this page is supplied with your wood headboard for attaching the bed frame to the headboard. The metal bed frame is supplied with its own assembly instructions and hardware.

Step 1

Attach the headboard assembly to the metal frame using JCB (G), flat washer (H), and split washer (I) then tighten with Allen wrench (F), as shown below.

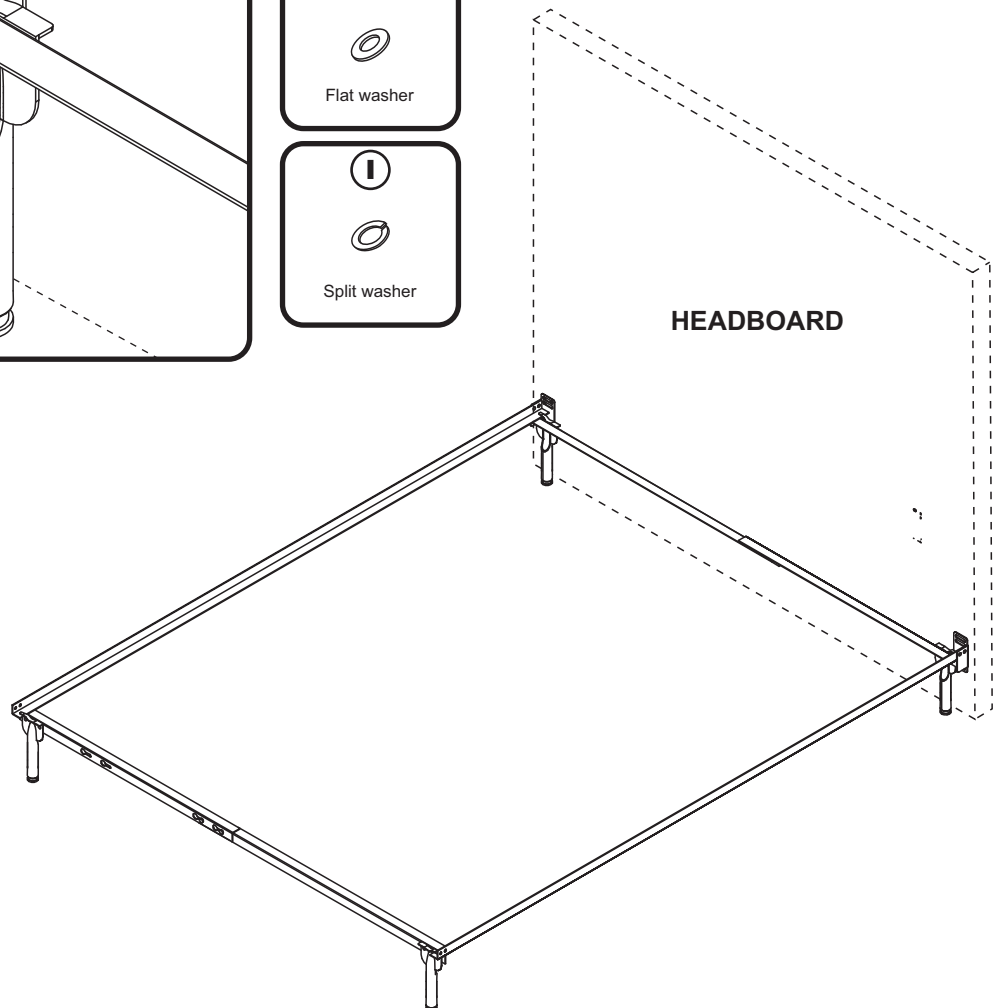
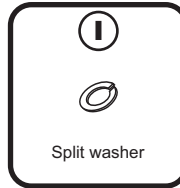
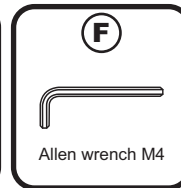
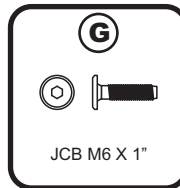
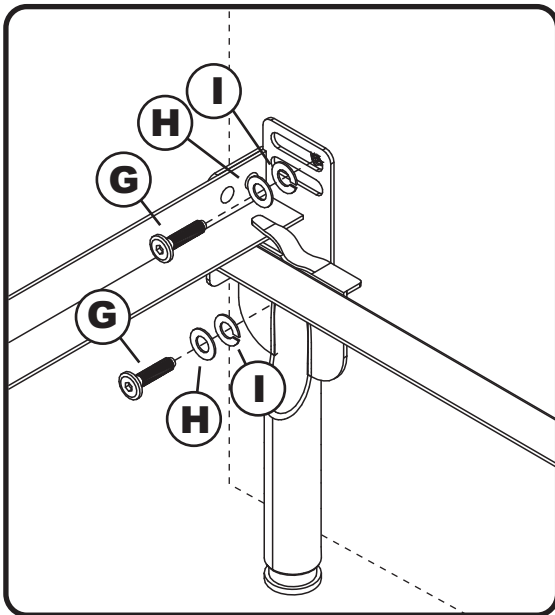

Congratulations!

Your bed is now ready for use.

To ensure lasting safety, we recommend that you periodically check that all screws are tight and all parts are secure.