

# ASSEMBLY INSTRUCTION

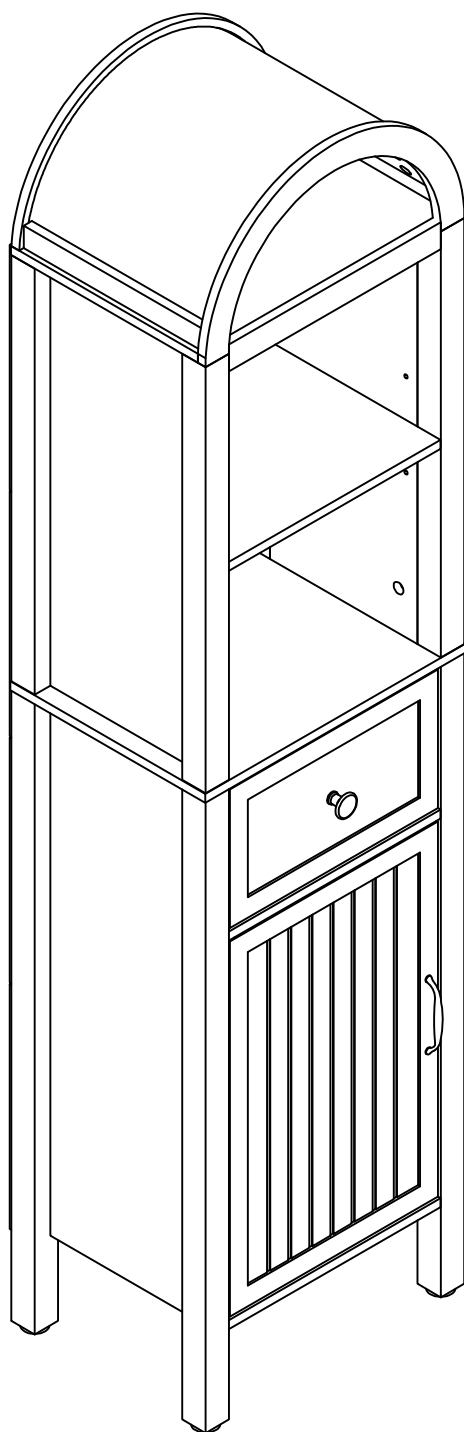

## Estimated time for assembly

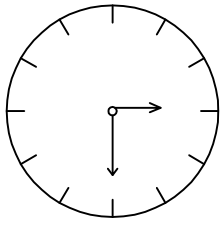

**60:00**

---

## What you need

- Use the packaging carton as a working surface to prevent product damage during assembly.
- Phillips head screwdriver.

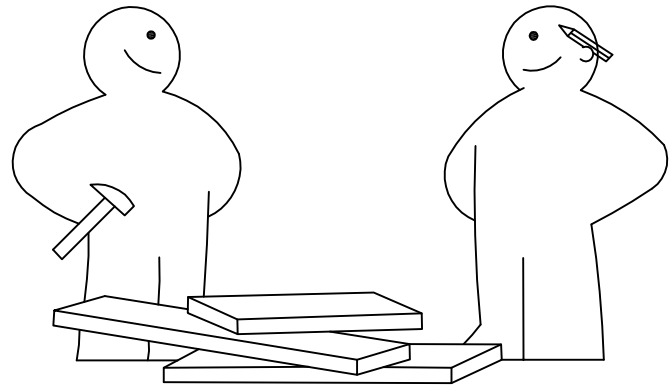
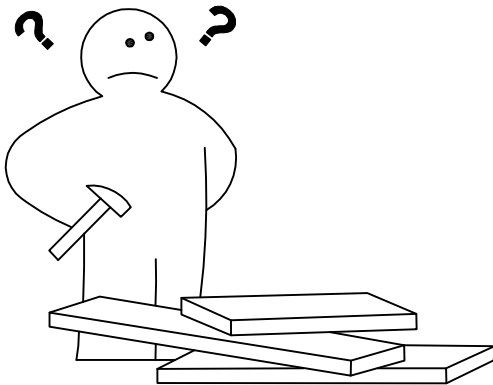
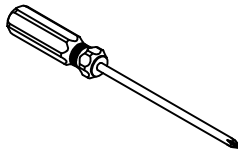







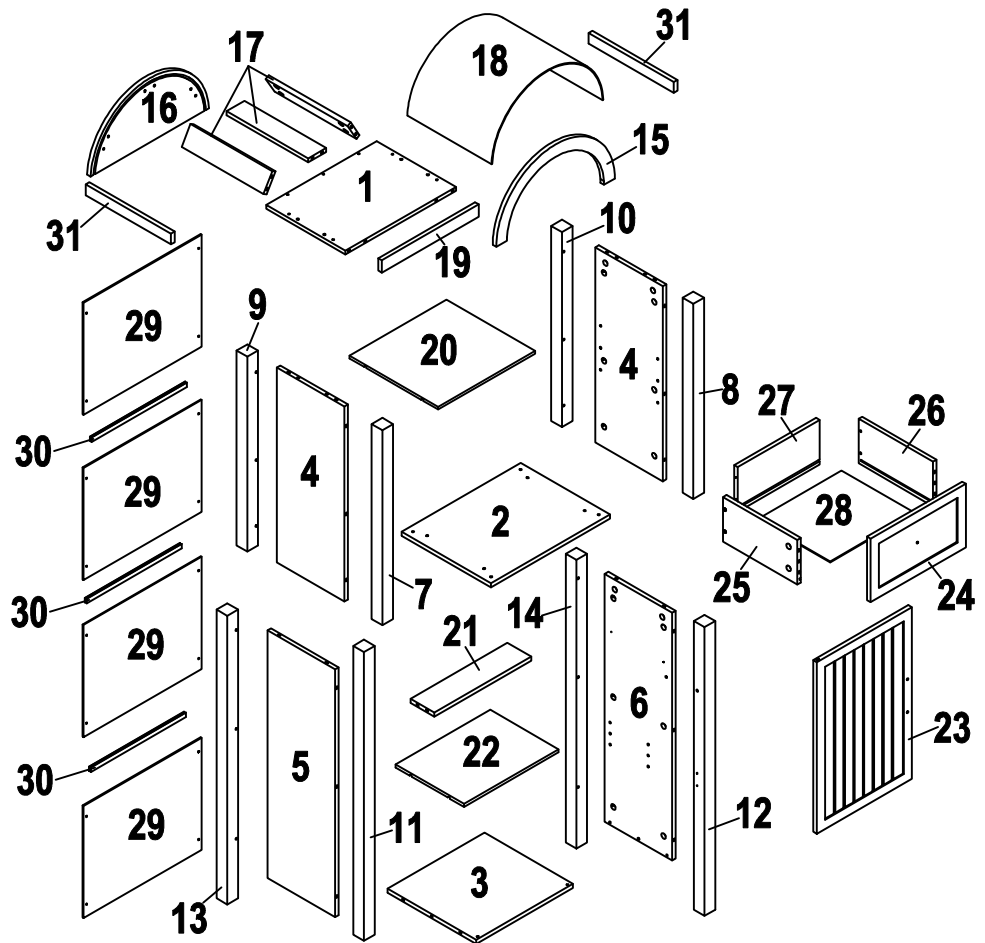

---

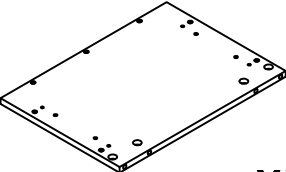
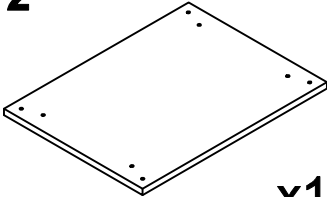
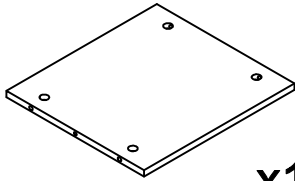
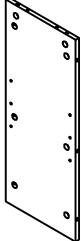
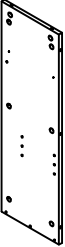
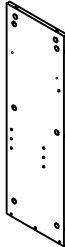
## IMPORTANT:







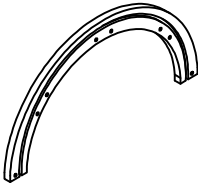
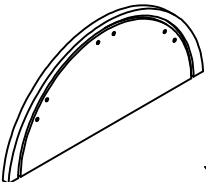

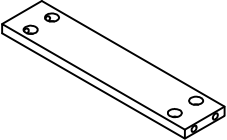
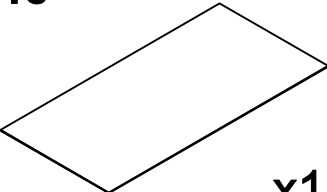
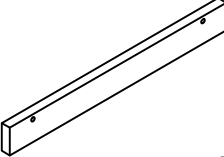
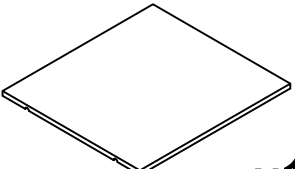
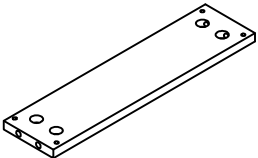
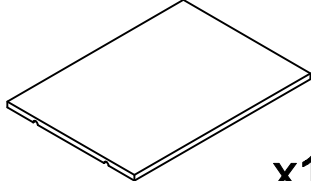
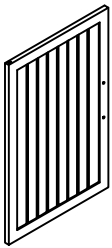
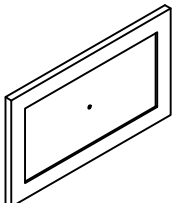
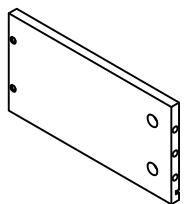
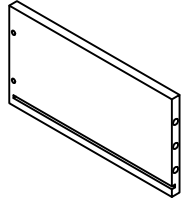
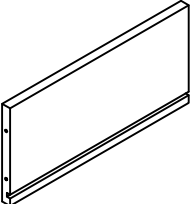
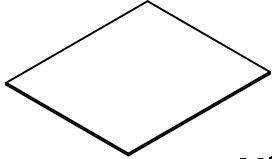
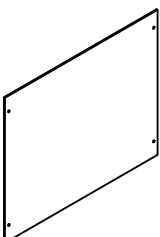
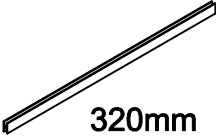
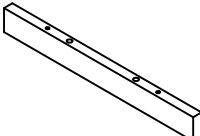



1. Do not tighten bolts / screws completely until all bolts / screws are lined up and inserted into holes.
2. Do not over tighten screws and bolts to avoid stripping
3. Please use hand tools to assemble this product, Do not use power tools.

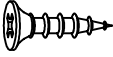
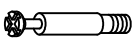

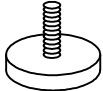
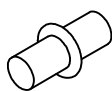
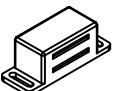
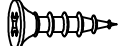
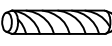
# Packing List

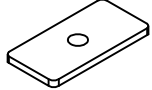
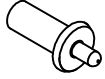
<b>1</b>  x1	<b>2</b>  x1	<b>3</b>  x1	<b>4</b>  x2
<b>5</b>  x1	<b>6</b>  x1	<b>7</b>  x1	<b>8</b>  x1
<b>9</b>  x1	<b>10</b>  x1	<b>11</b>  x1	<b>12</b>  x1
<b>13</b>  x1	<b>14</b>  x1	<b>15</b>  x1	<b>16</b>  x1

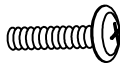
<b>17</b>  x3	<b>18</b>  x1	<b>19</b>  x1	<b>20</b>  x1
<b>21</b>  x1	<b>22</b>  x1	<b>23</b>  x1	<b>24</b>  x1
<b>25</b>  x1	<b>26</b>  x1	<b>27</b>  x1	<b>28</b>  x1
<b>29</b>  x4	<b>30</b>  320mm x3	<b>31</b>  x2	

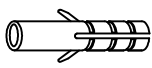
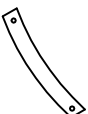
<b>A1</b>  x1	<b>A2</b>  x1	<b>B1</b>  x1	<b>B2</b>  x1	<b>C</b> M3.5x12  x27
<b>D</b>  x60	<b>E</b>  x60	<b>F</b>  x4	<b>G</b>  x8	<b>H</b>  x1
<b>I</b> M3x14  x2	<b>J</b> M6x30  x12	<b>K</b> M5x40  x15	<b>L</b>  x1	<b>M</b>  x2
<b>N</b>  x1	<b>O</b> M4x16  x3	<b>P</b> M3.5x40  x6	<b>Q</b>  x1	<b>R</b>  x2
<b>S</b>  x2				

# Step 1

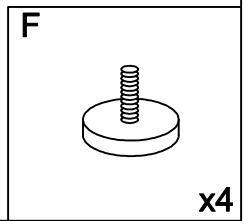
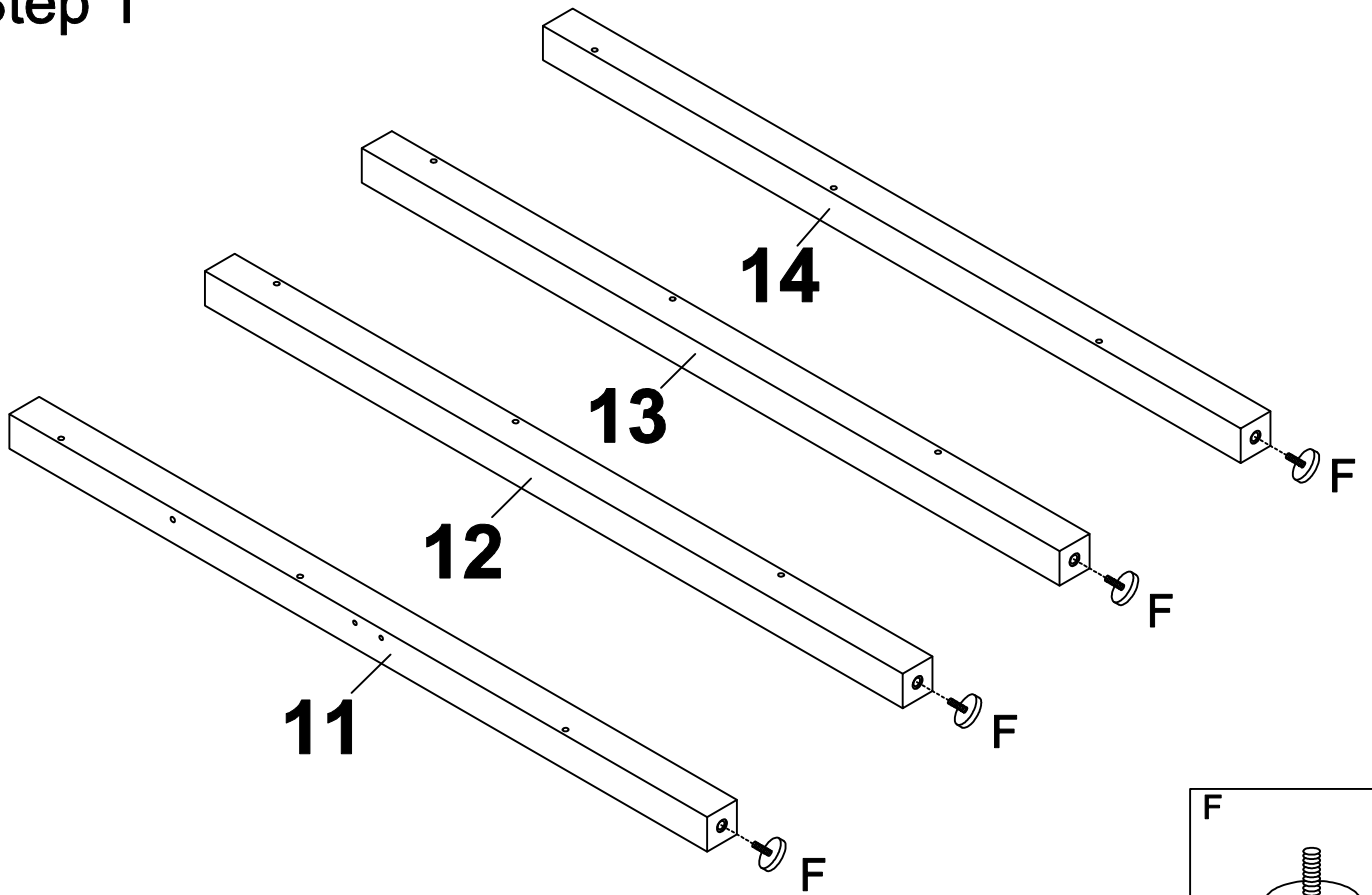

x4

# Step 2

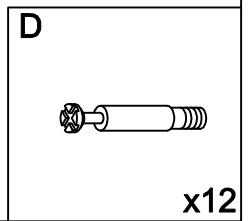
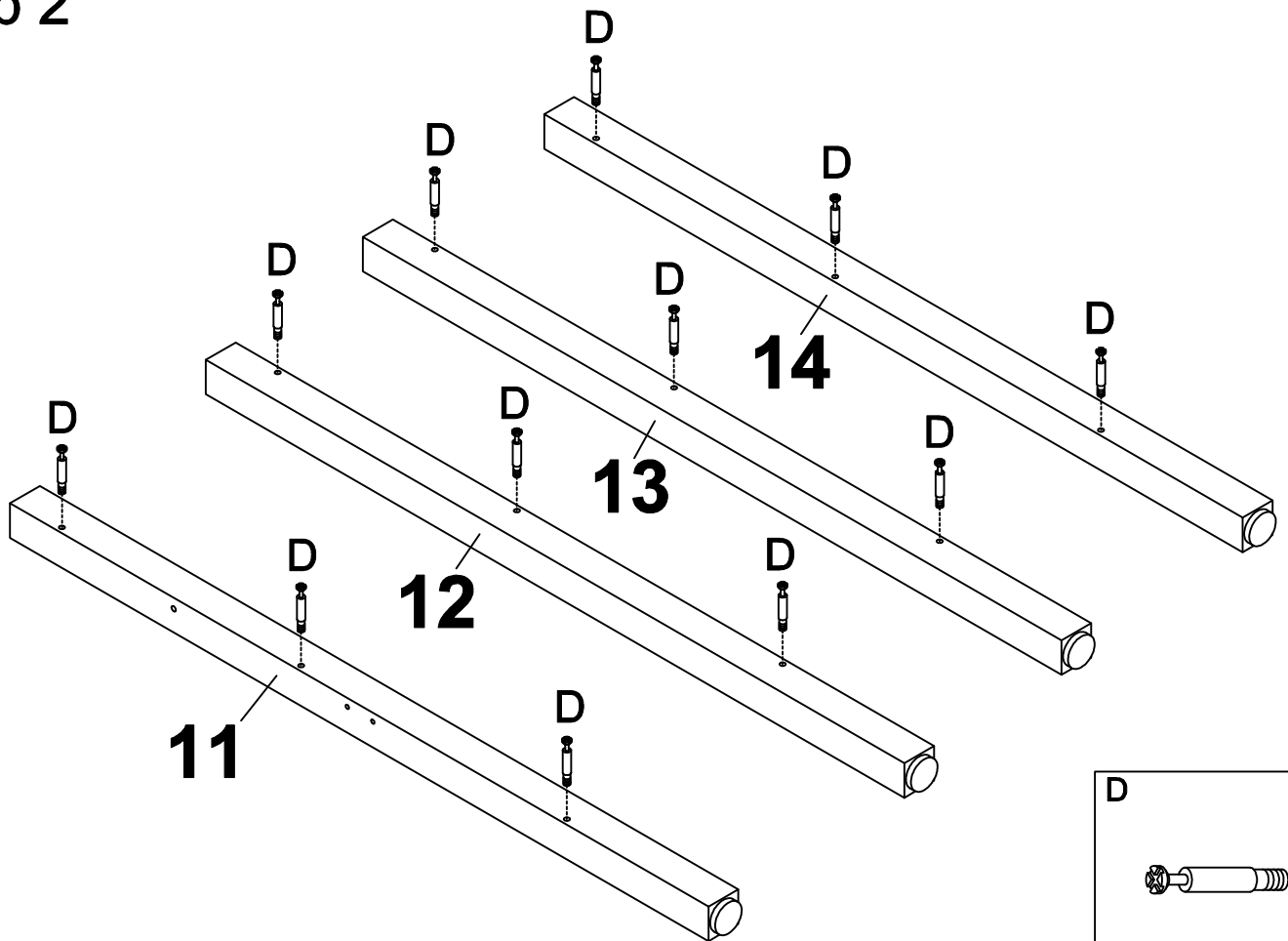

x12

# Step 3

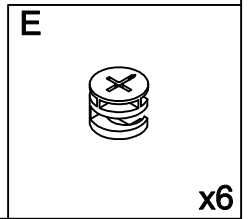
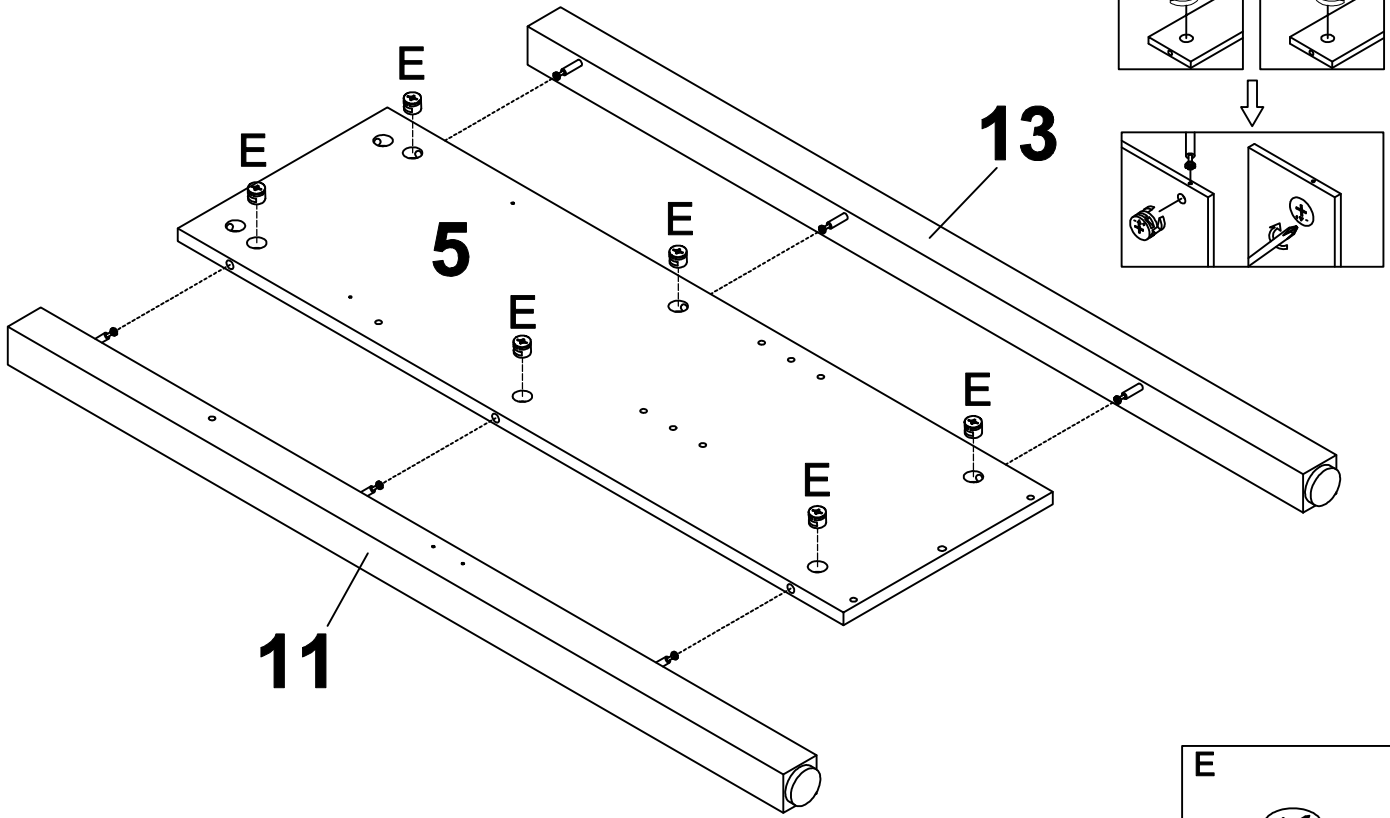

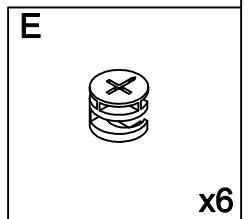
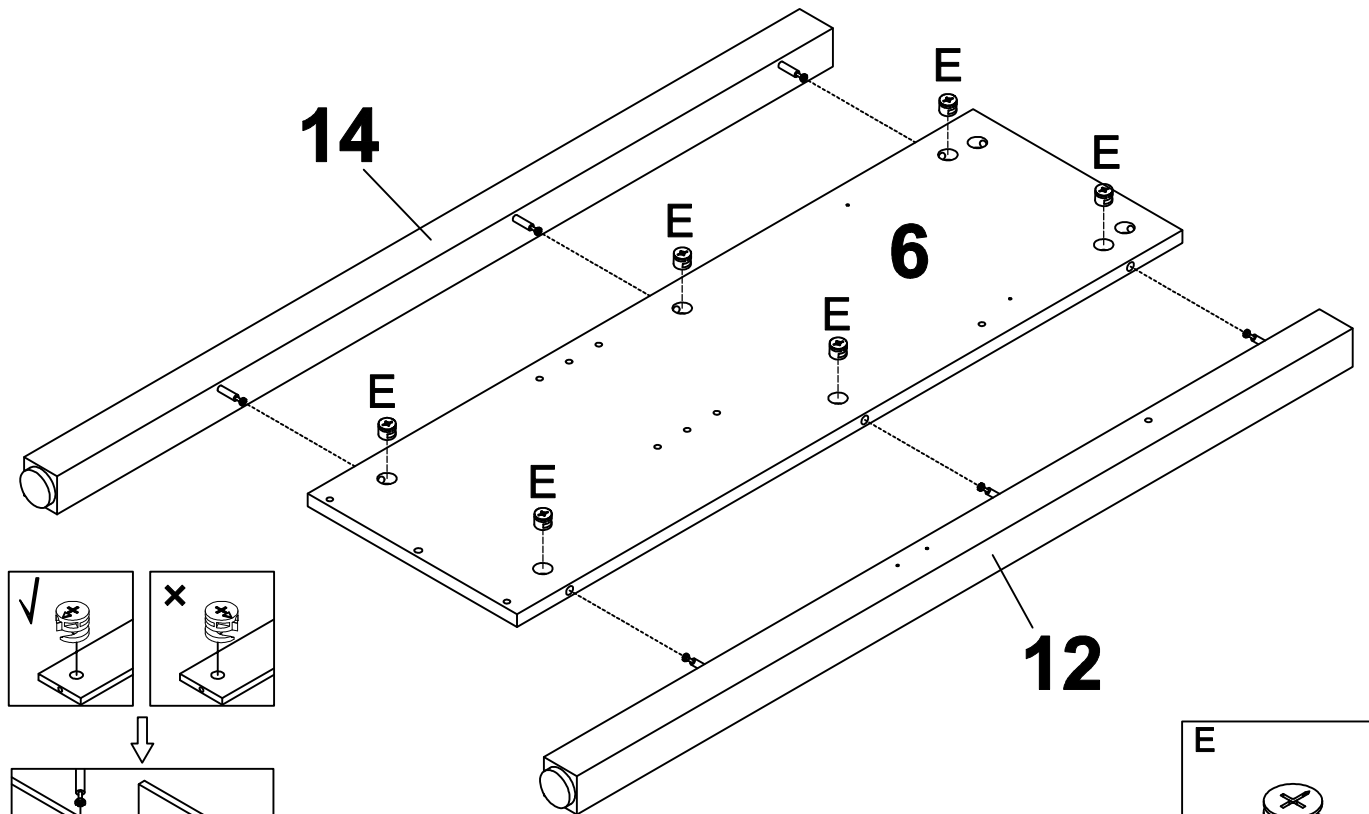

# Step 4

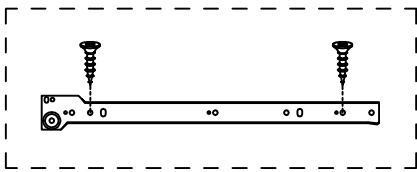
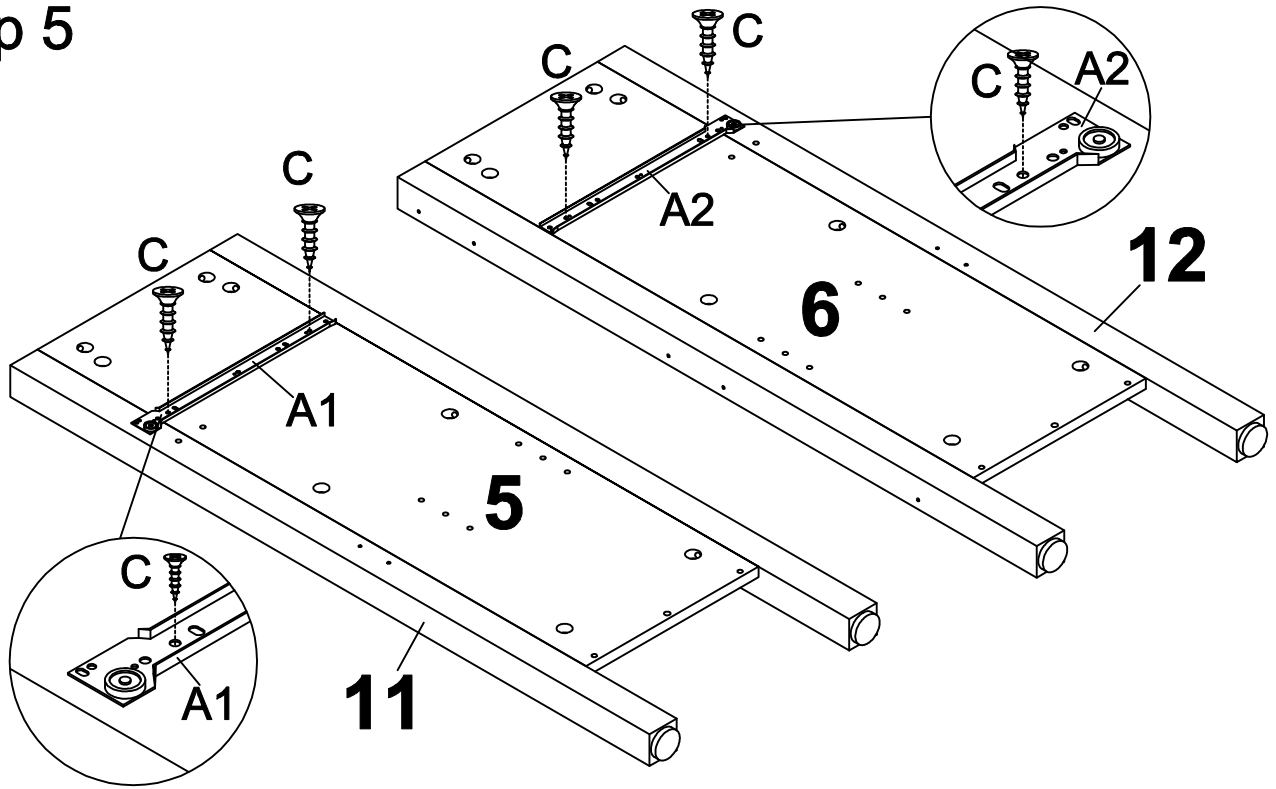

# Step 5

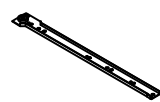

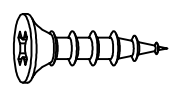
A1	A2	C M3.5x12
		
x1	x1	x4

# Step 6

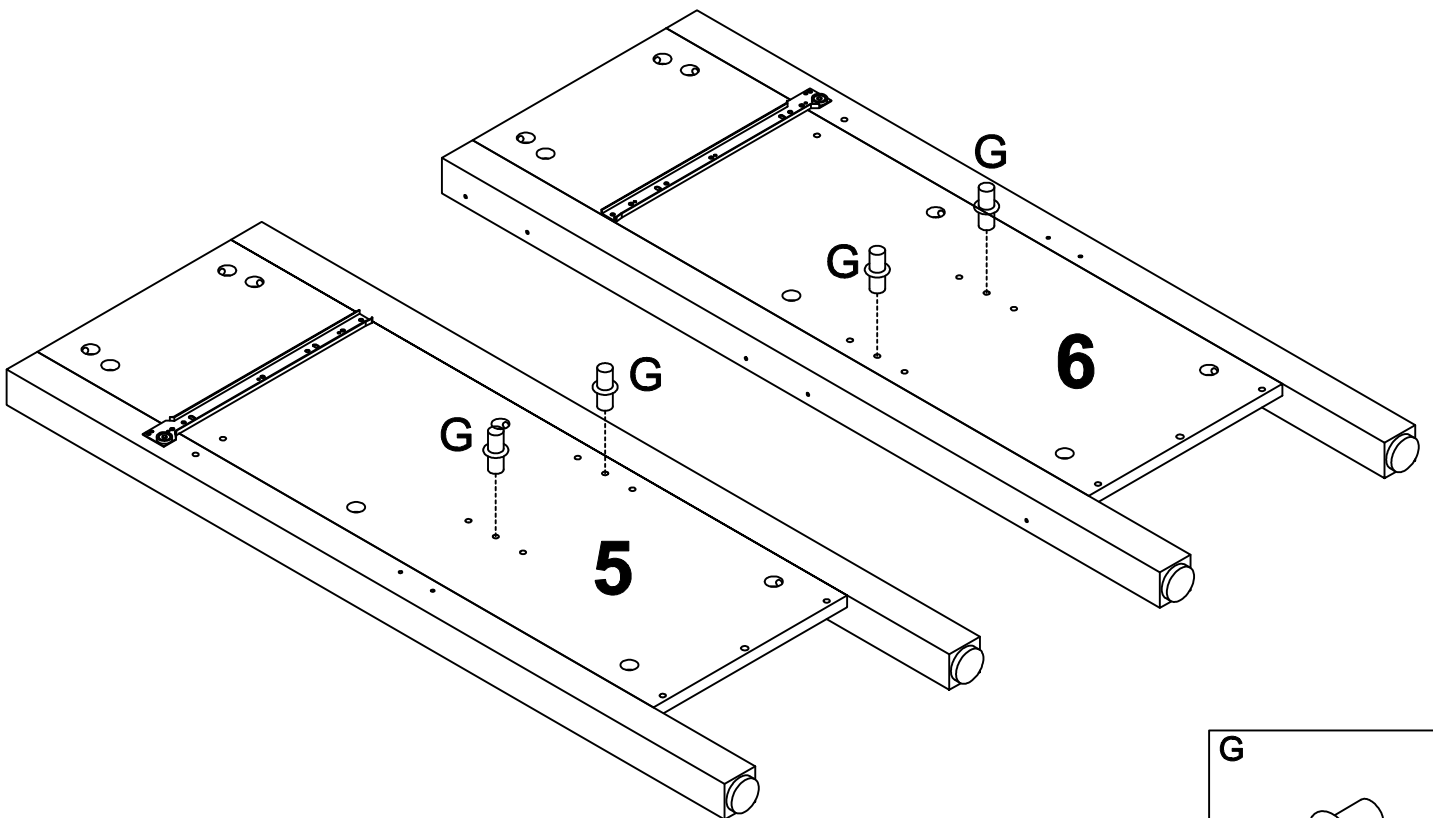

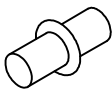
G

x4

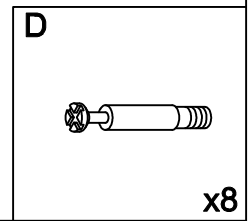
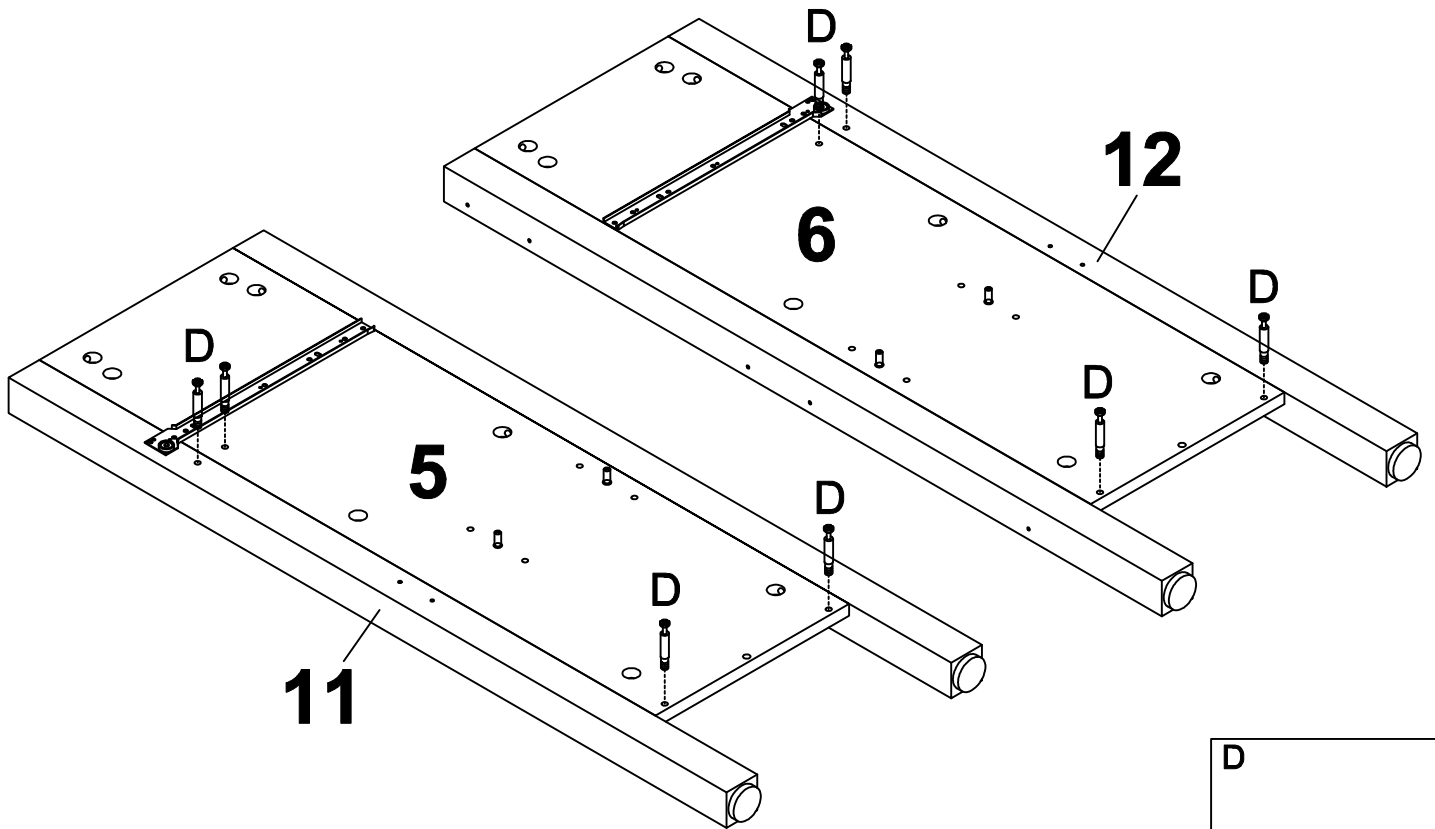
# Step 7

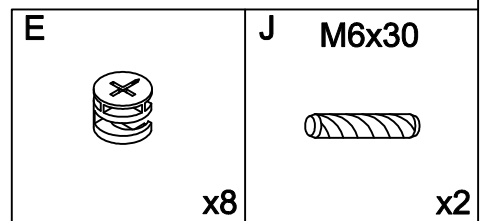
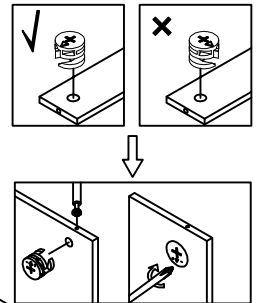
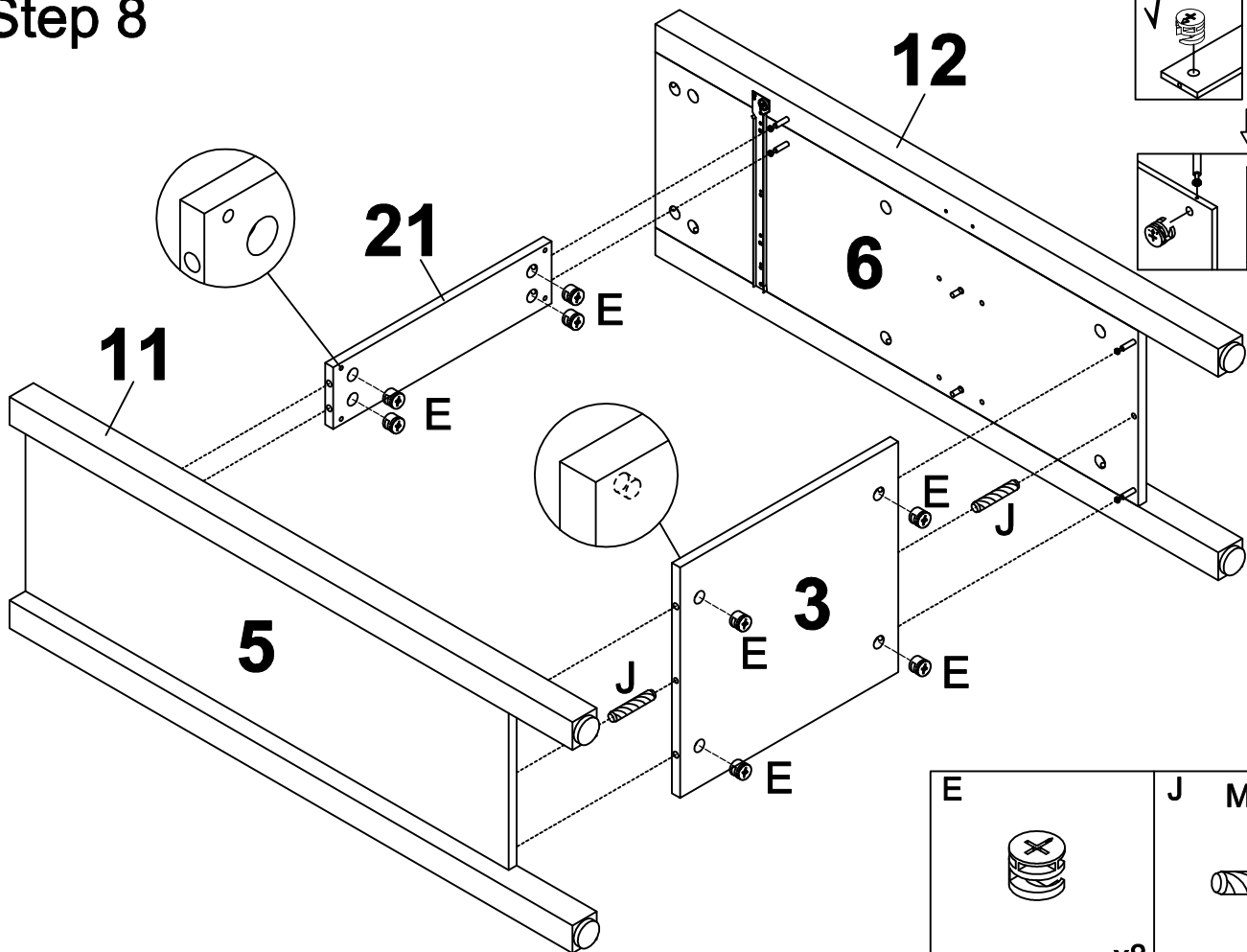

# Step 8



# Step 9

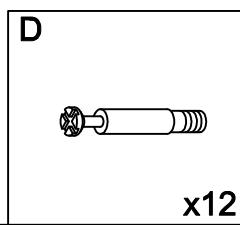
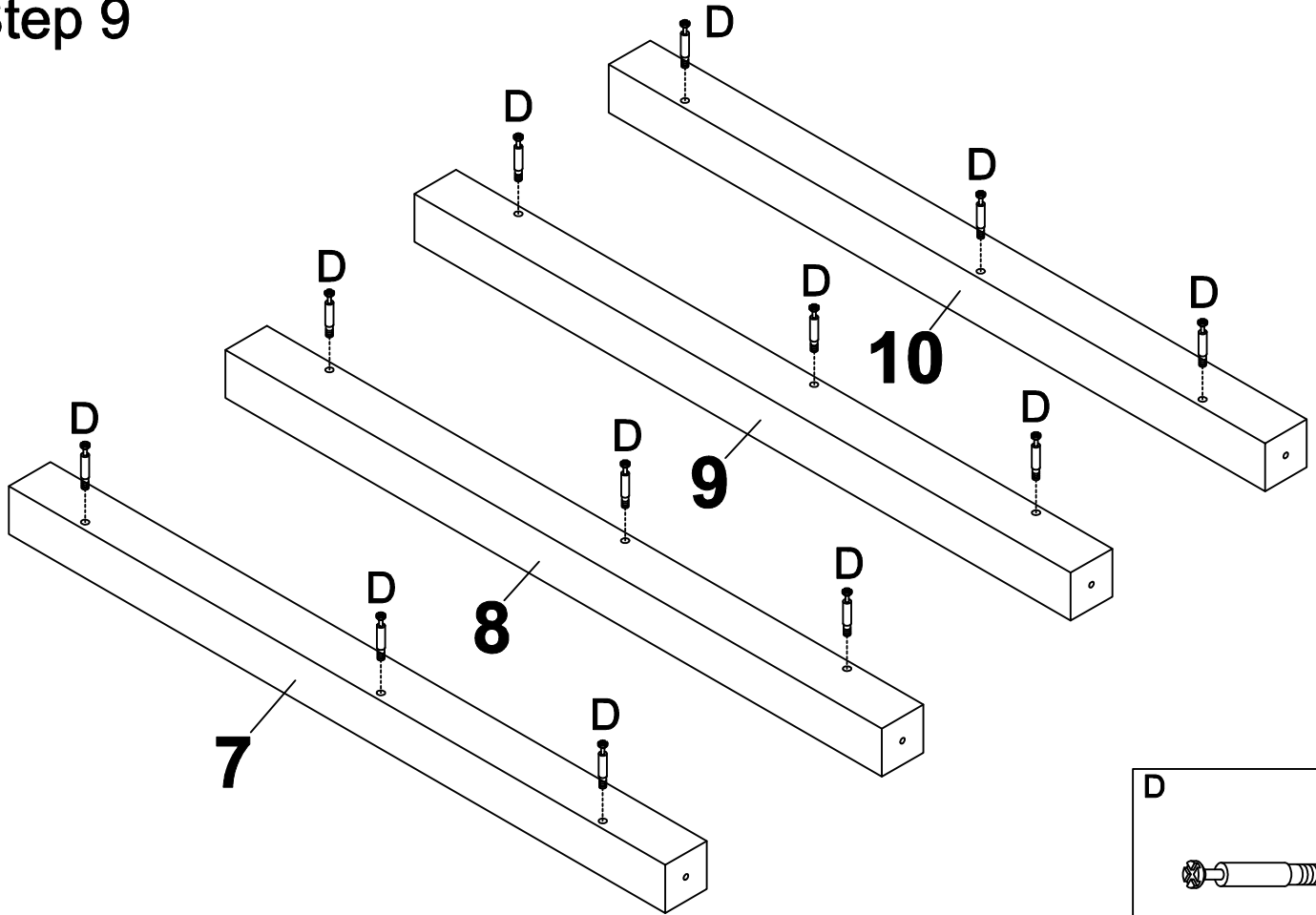

# Step 10

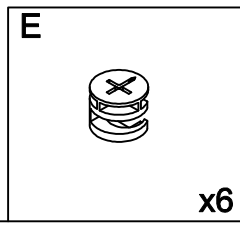
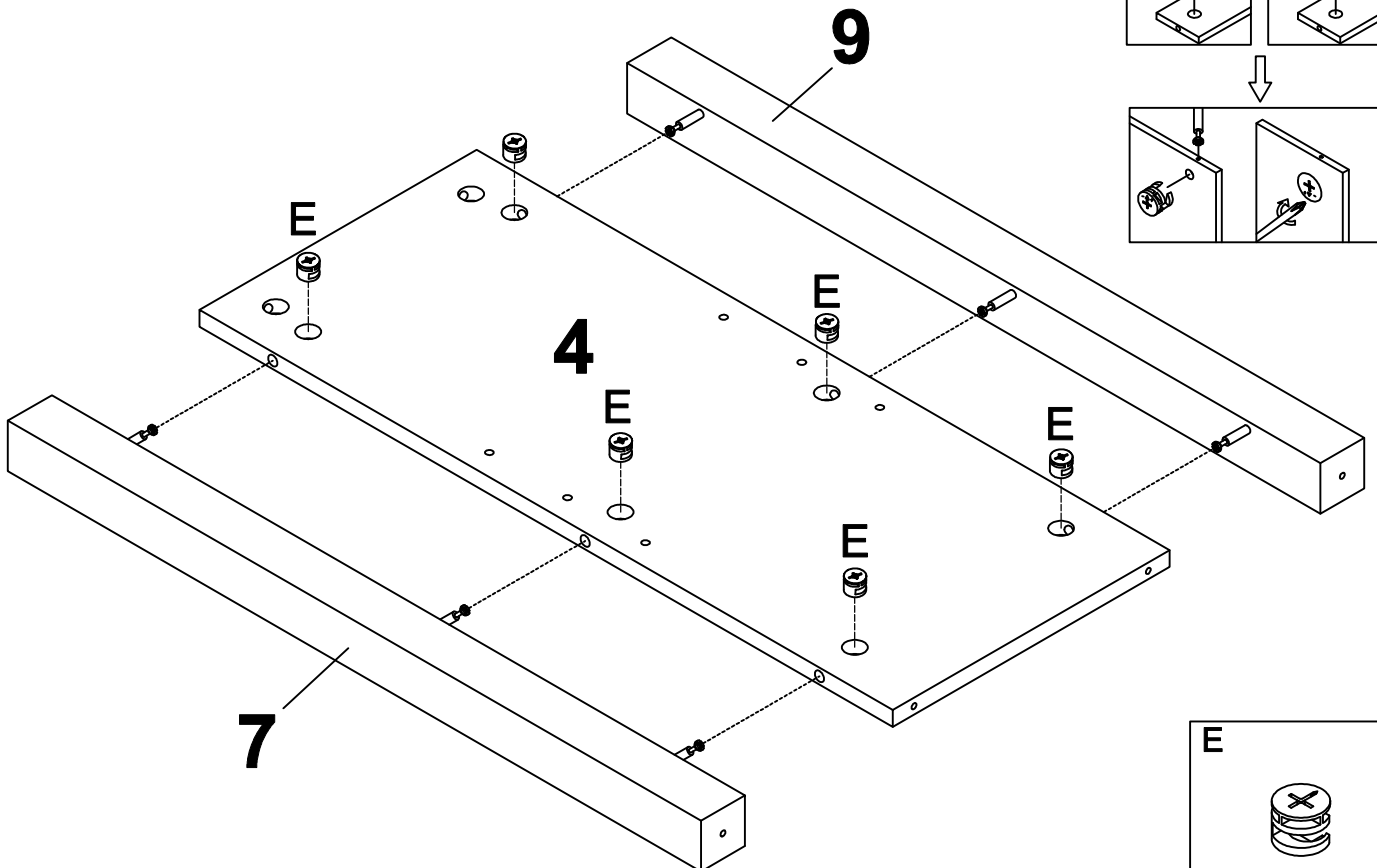

# Step 11

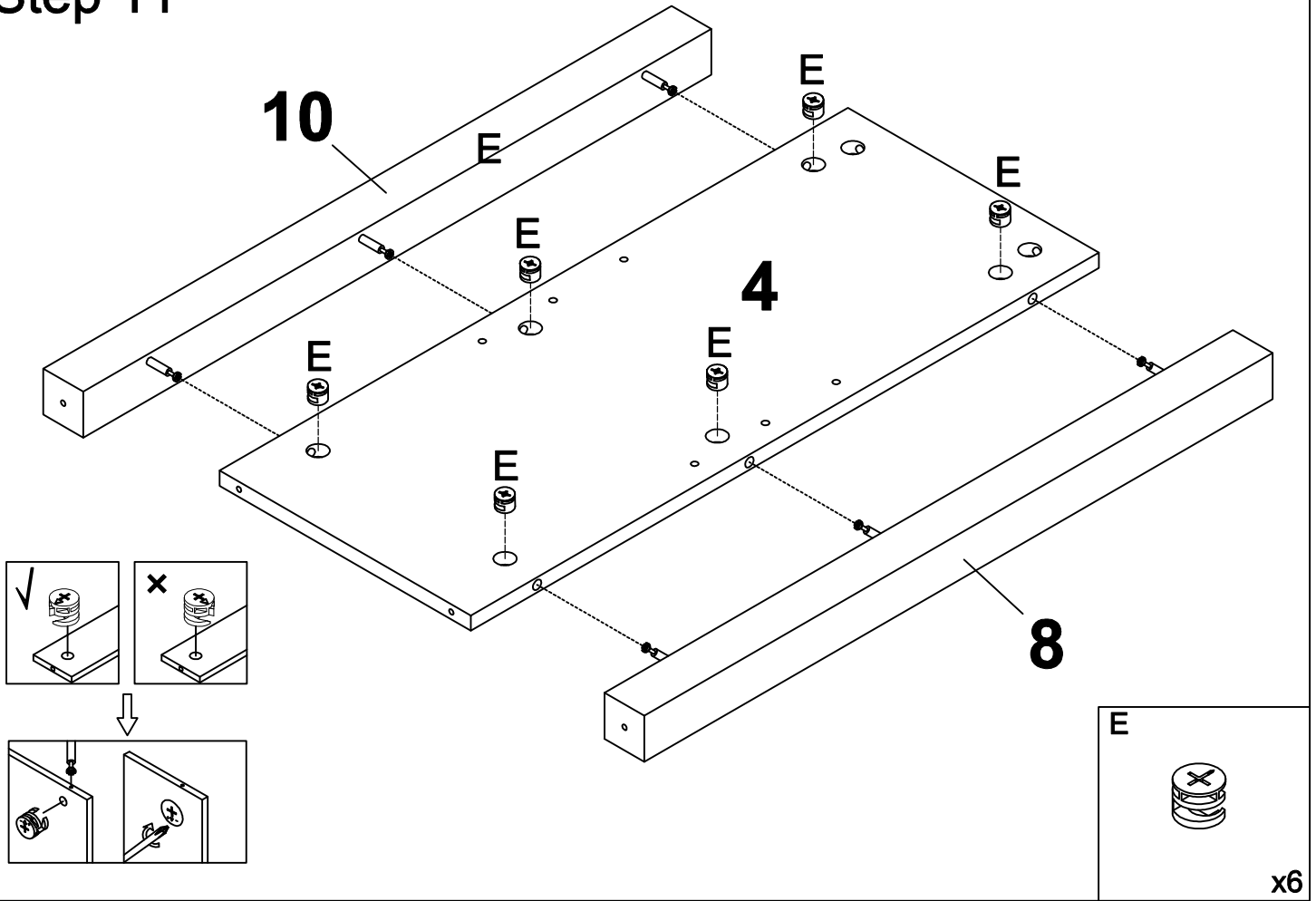

# Step 12

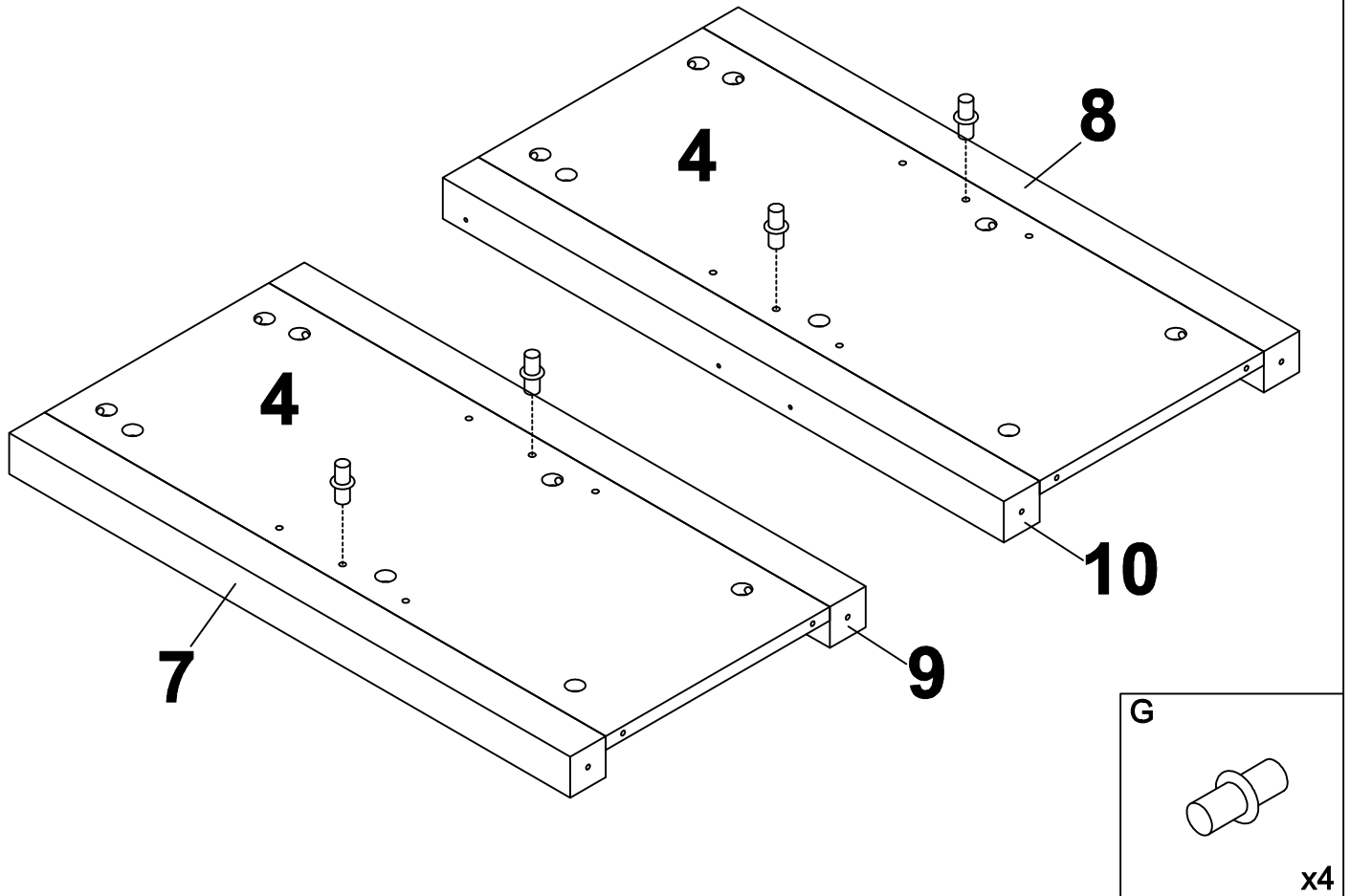

# Step 13

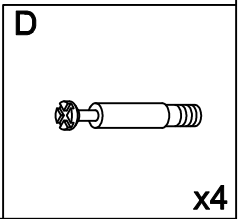
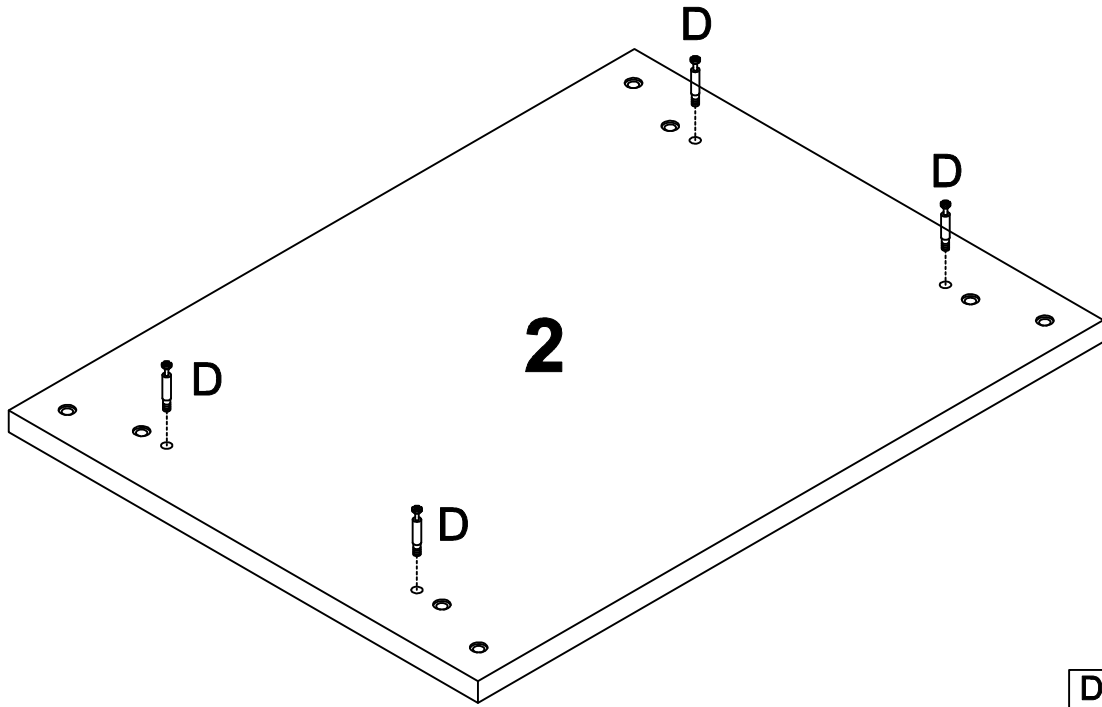

# Step 14

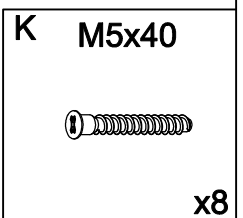
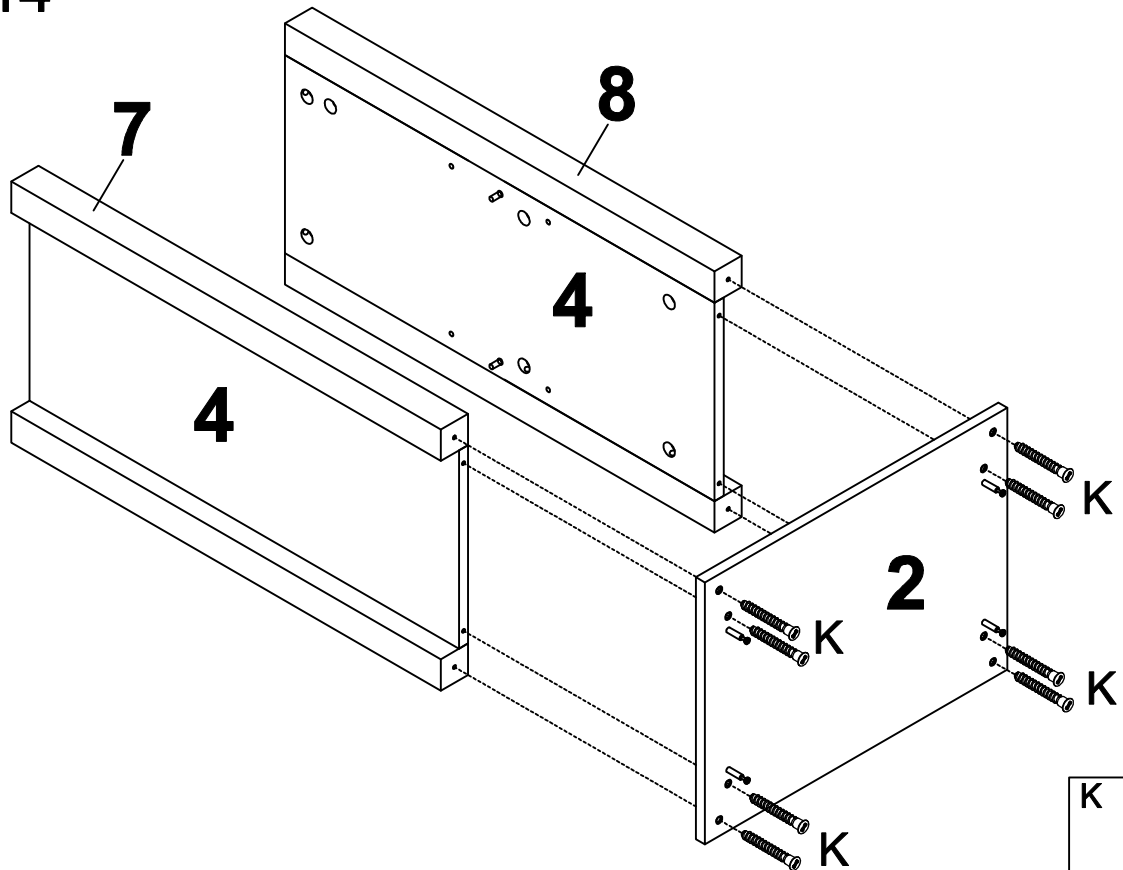

# Step 15

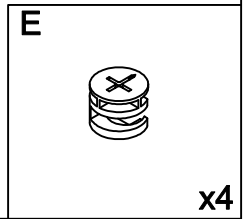
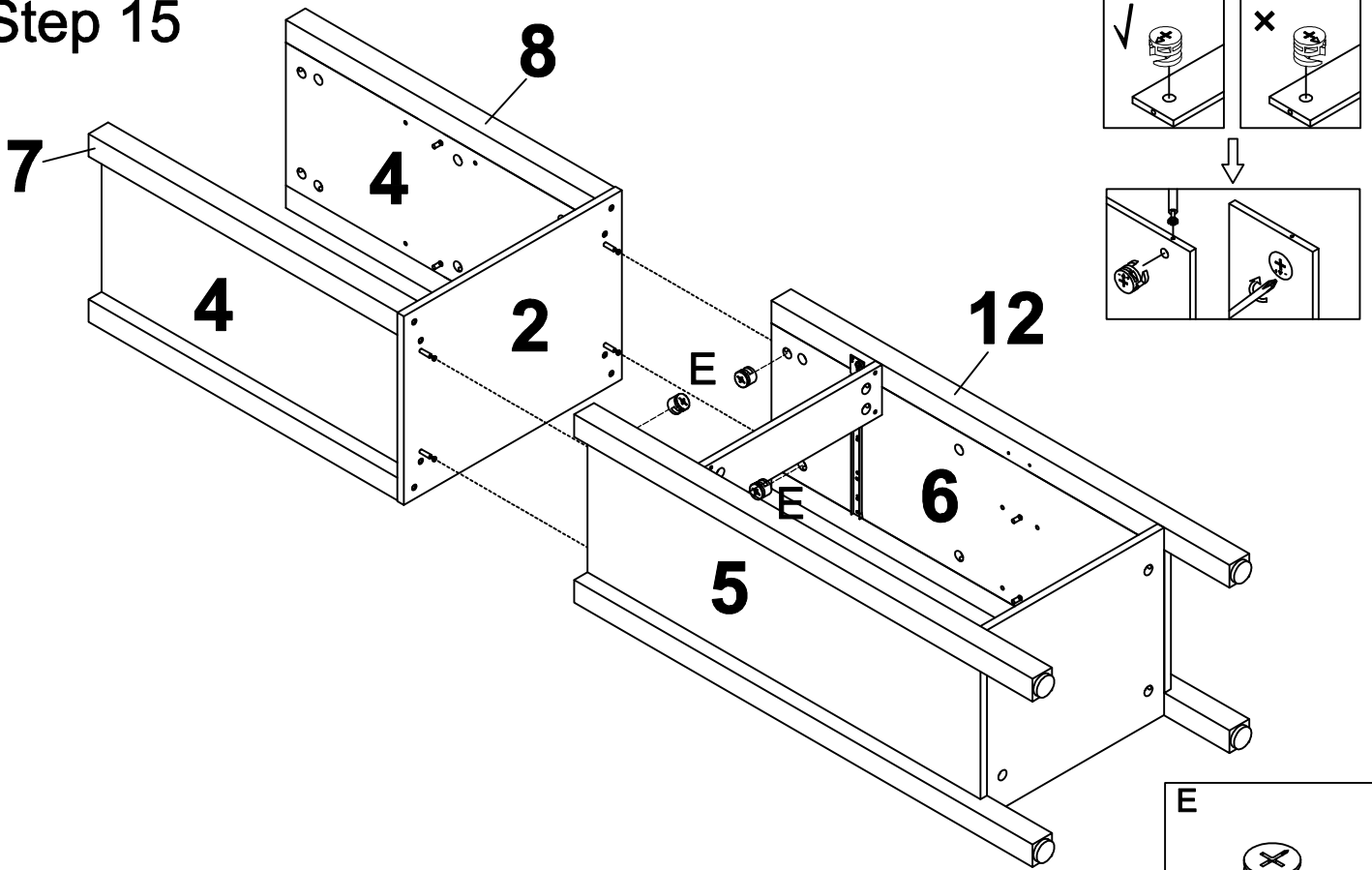

# Step 16

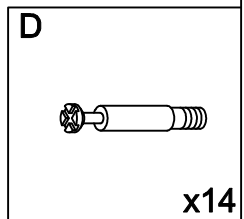
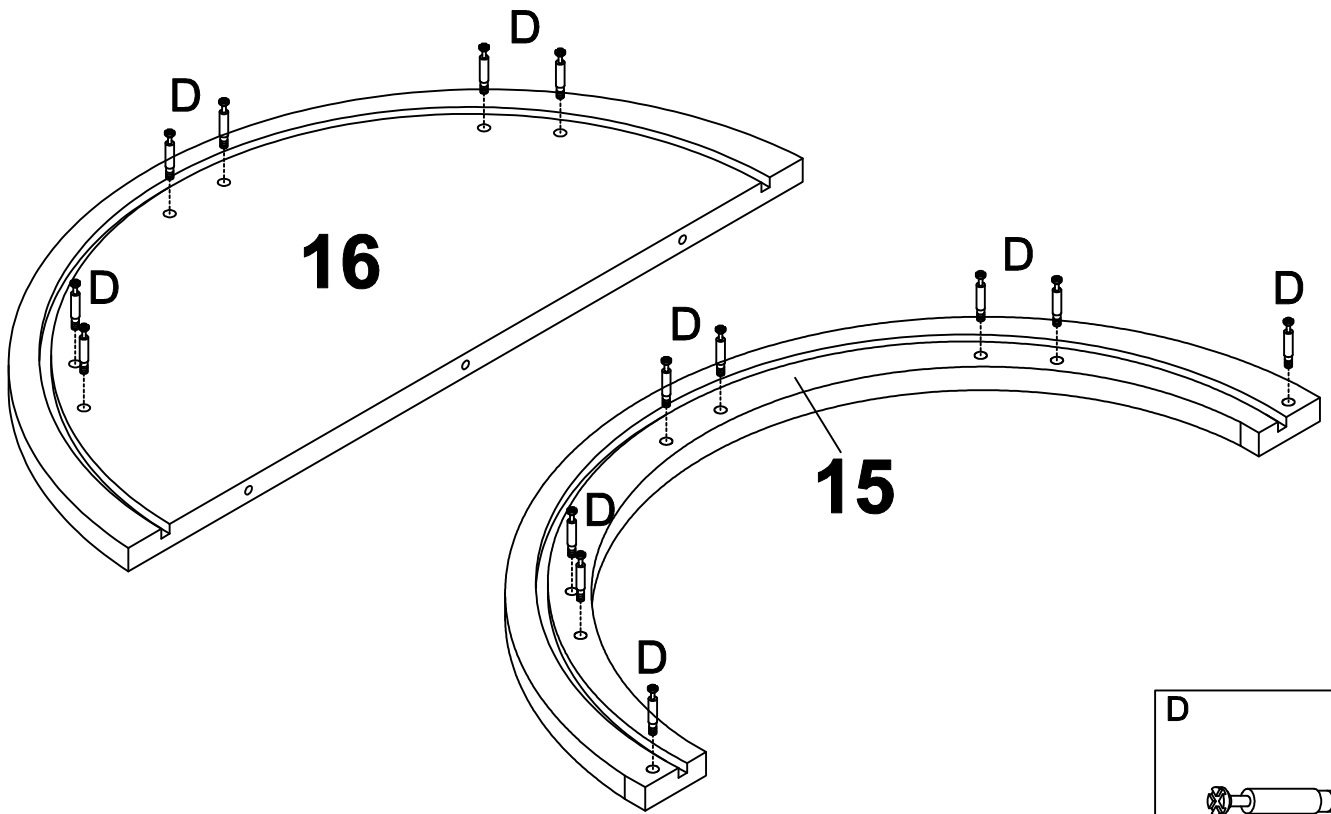

# Step 17

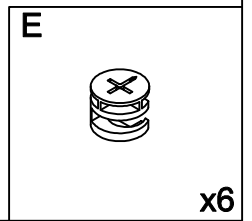
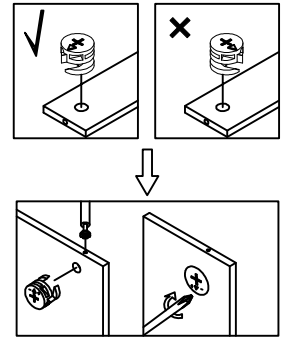
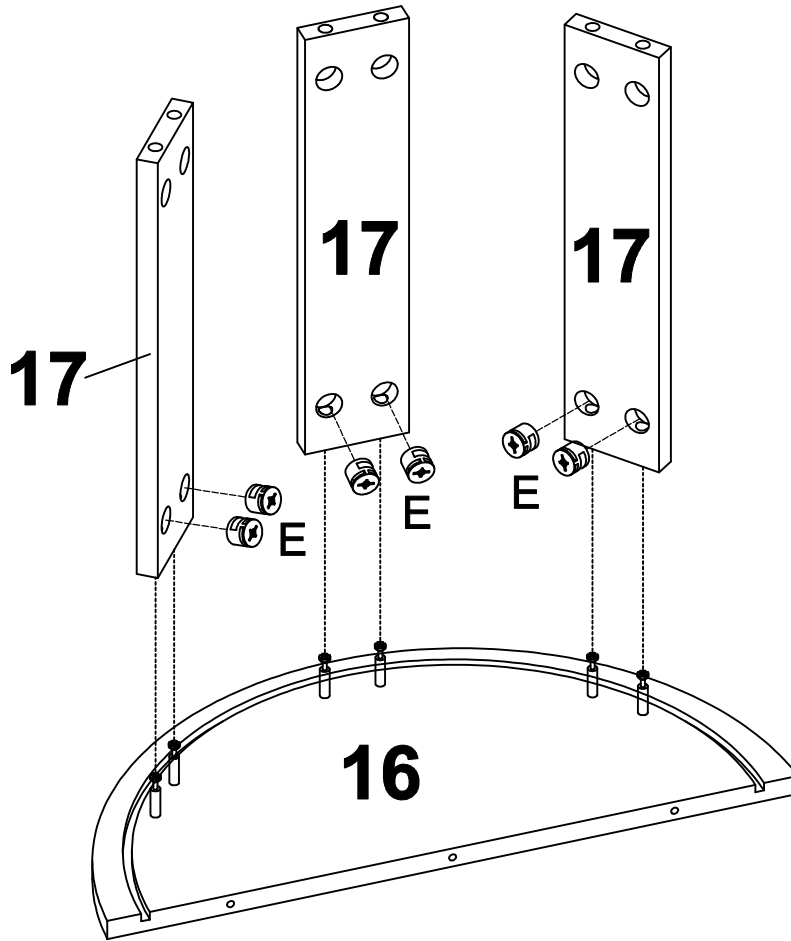

# Step 18

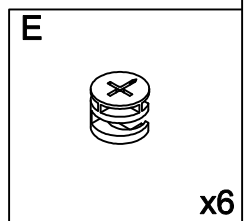
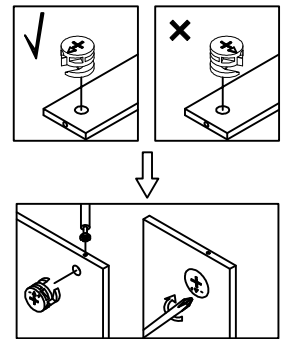
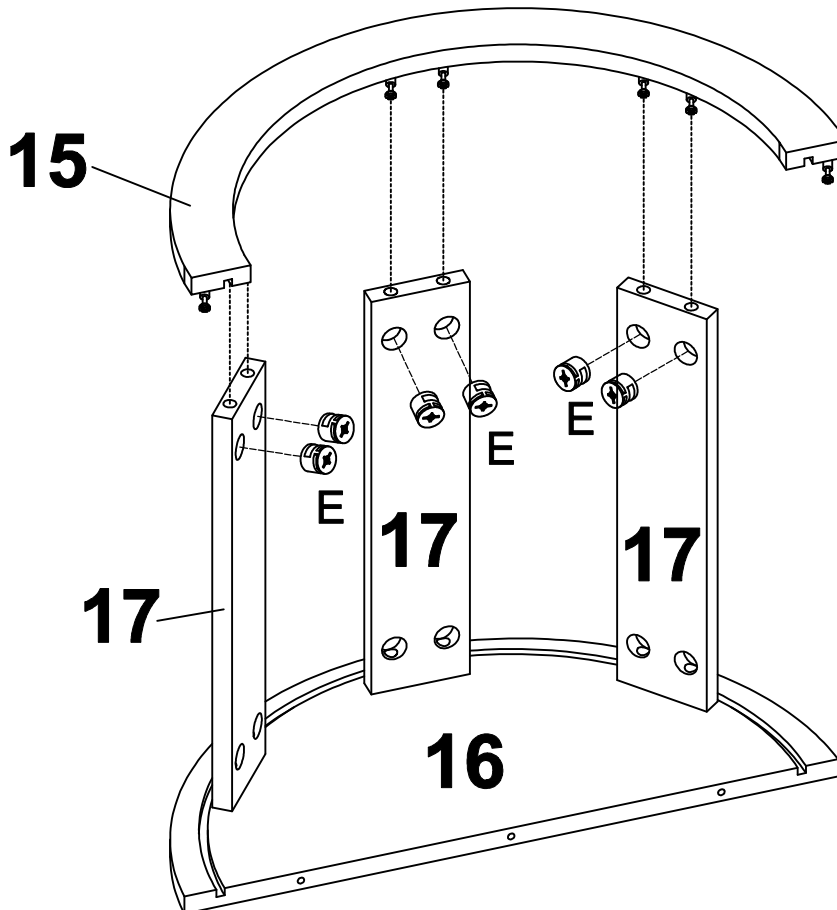

## Step 19

Parallel insert Part 18 by slowly. Be careful and don't insert rudely and insert no parallel quickly, or Part 18 will be broken.

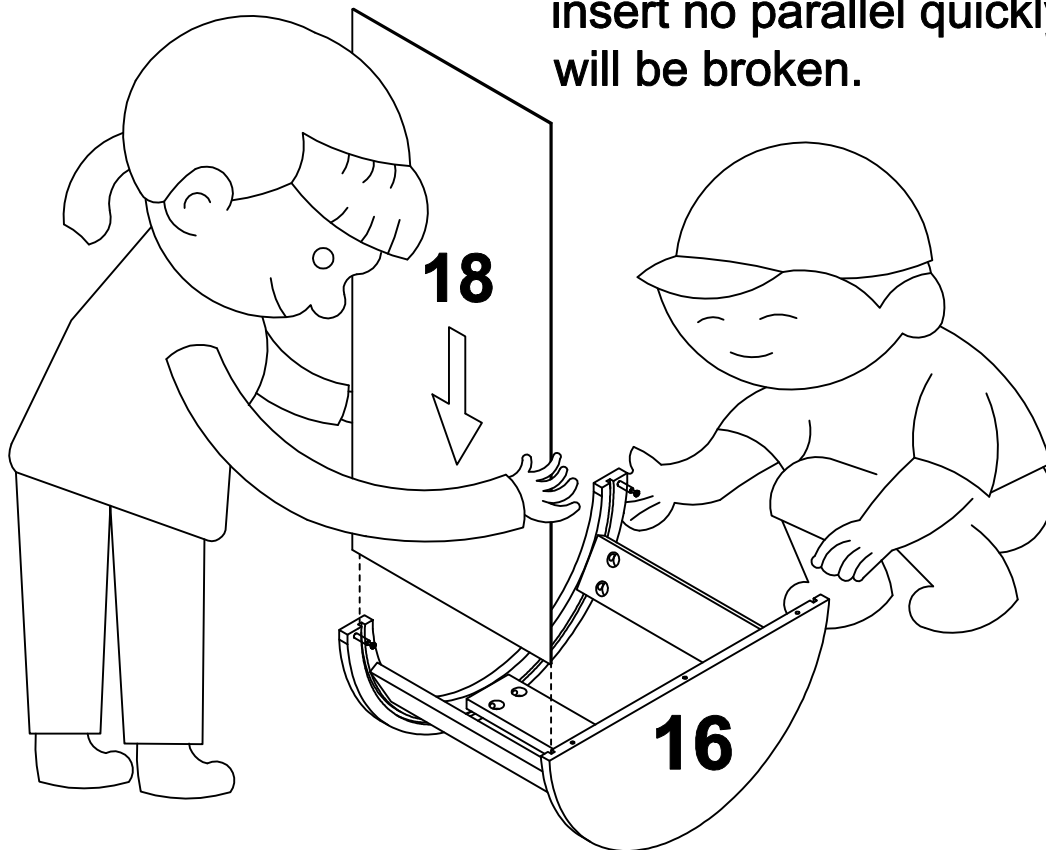

## Step 20

The D screw need to insert into the hole on the board 1.

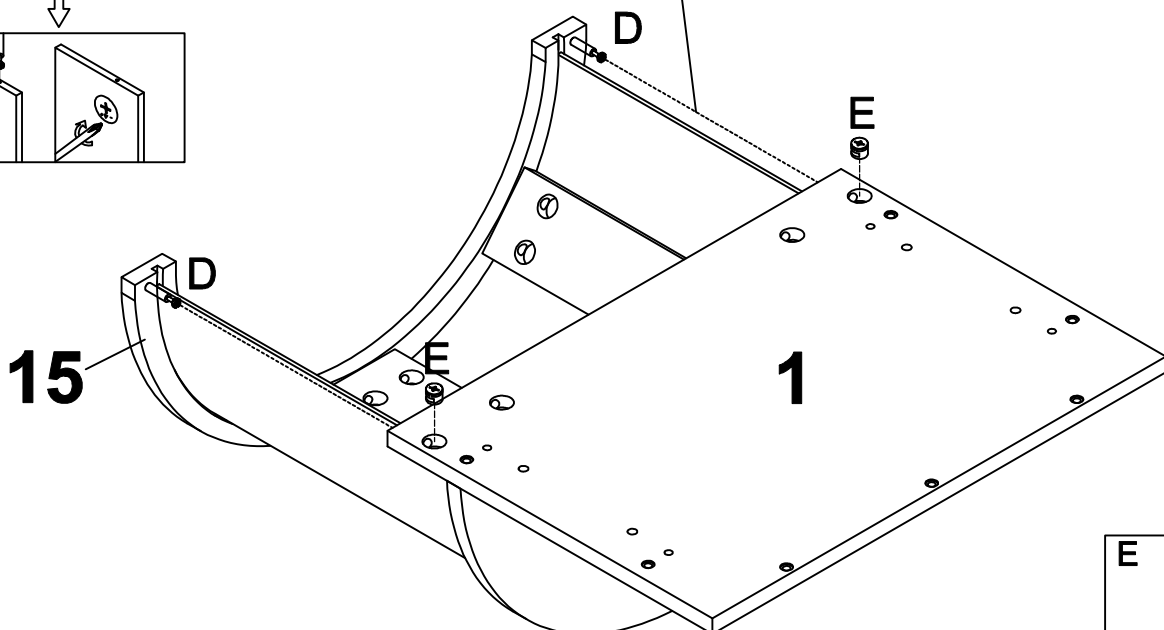
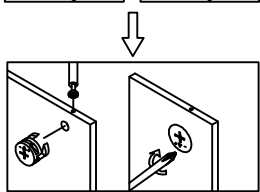
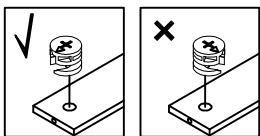

E



x2

# Step 21

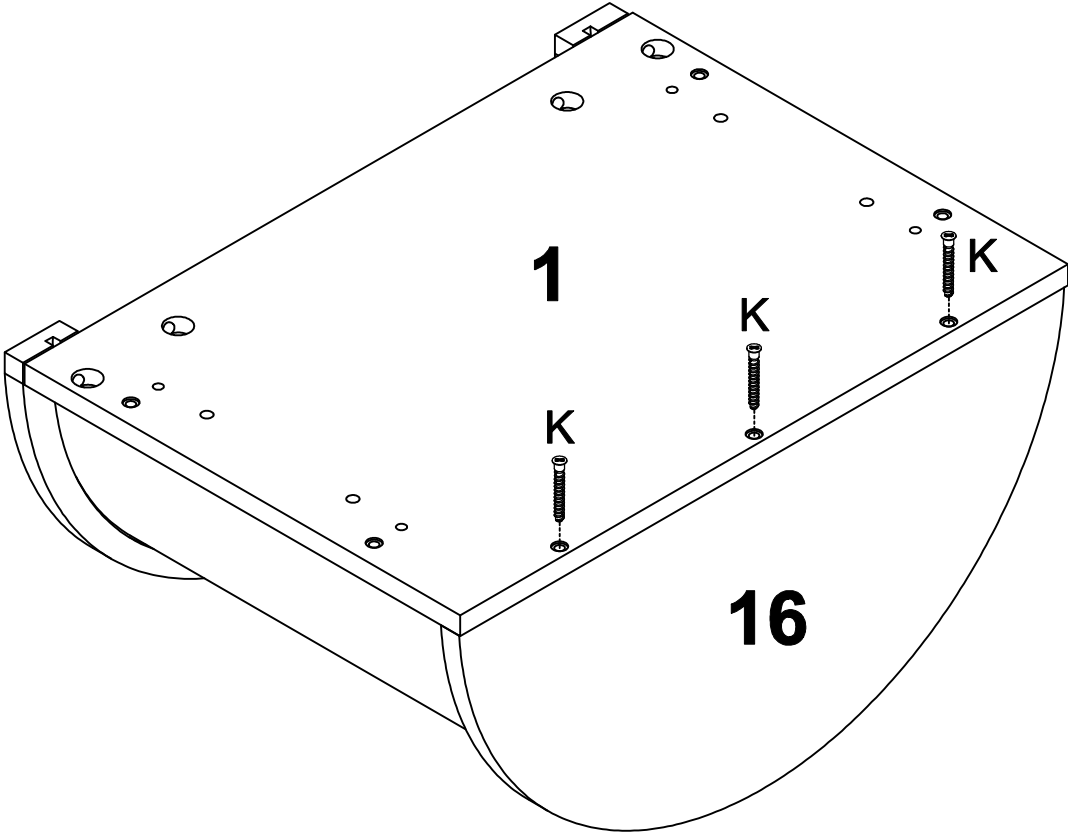

**K** M5x40



x3

# Step 22

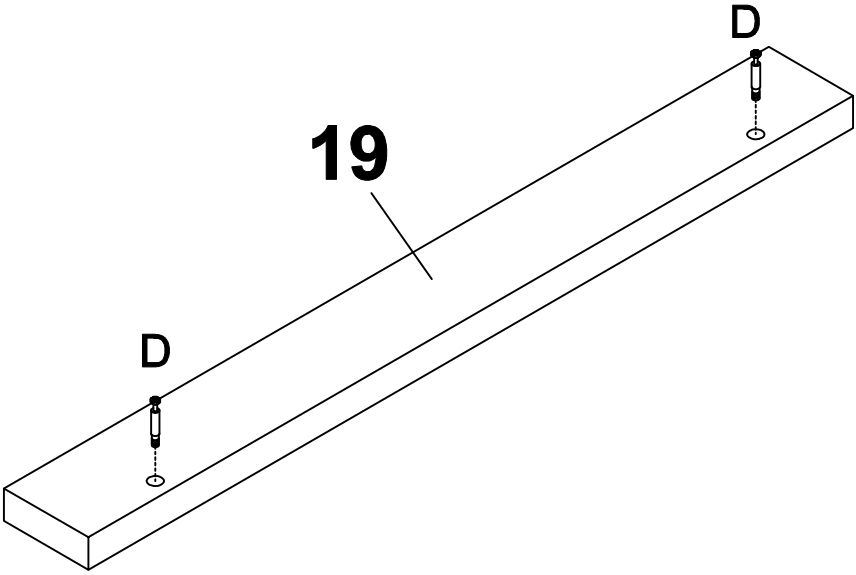

**D**

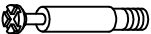

x2

# Step 23

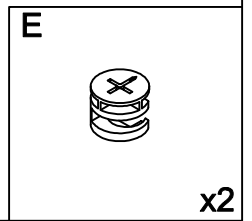
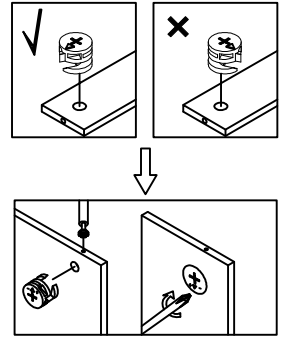
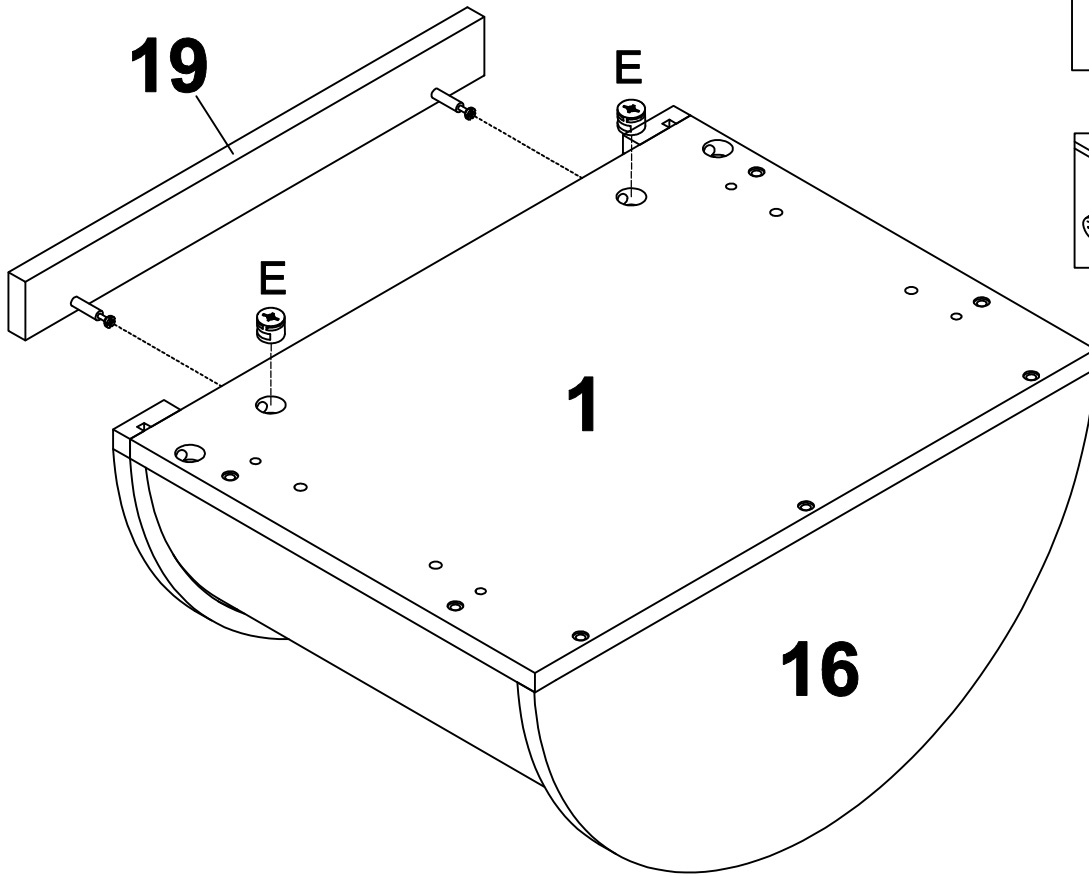

# Step 24

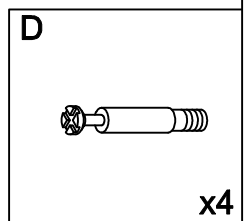
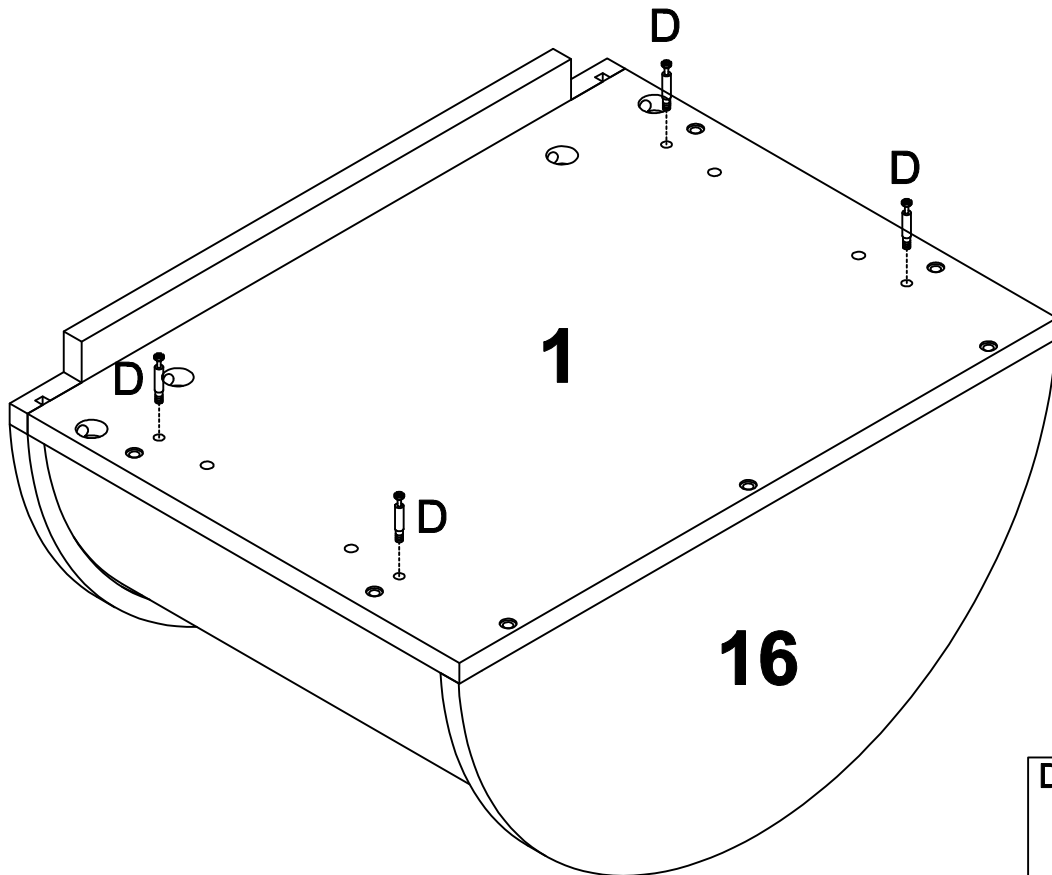

# Step 25

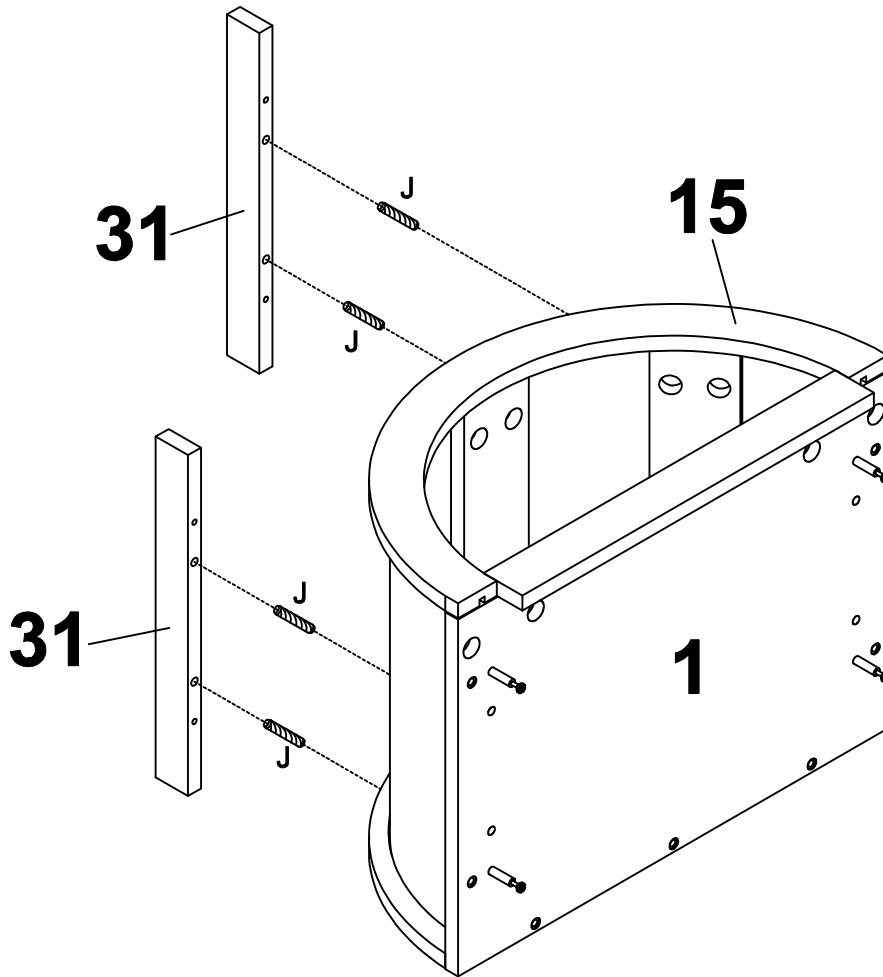

J M6x30



x4

# Step 26

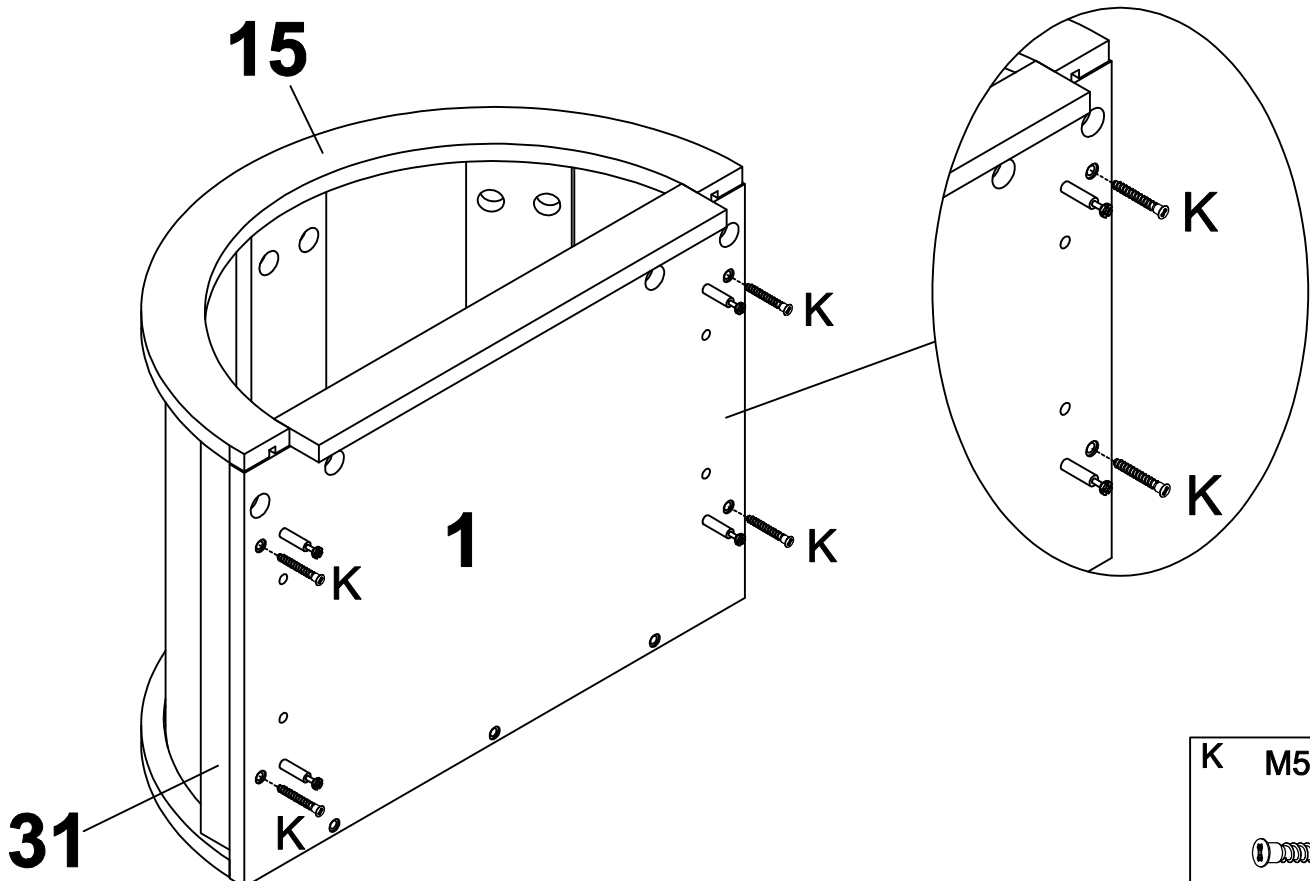



K M5x40

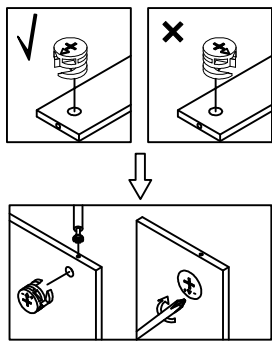
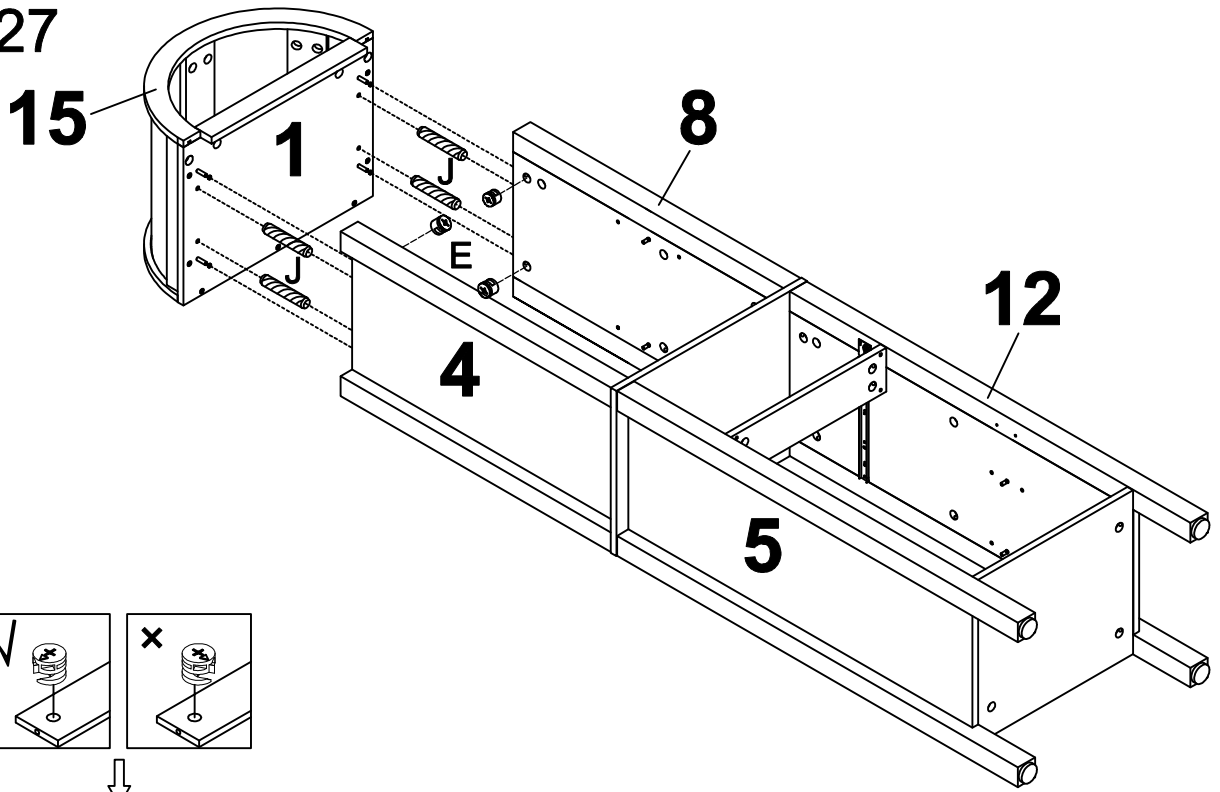

x4

# Step 27



E	J	M6x30
		
x4	x4	

# Step 28

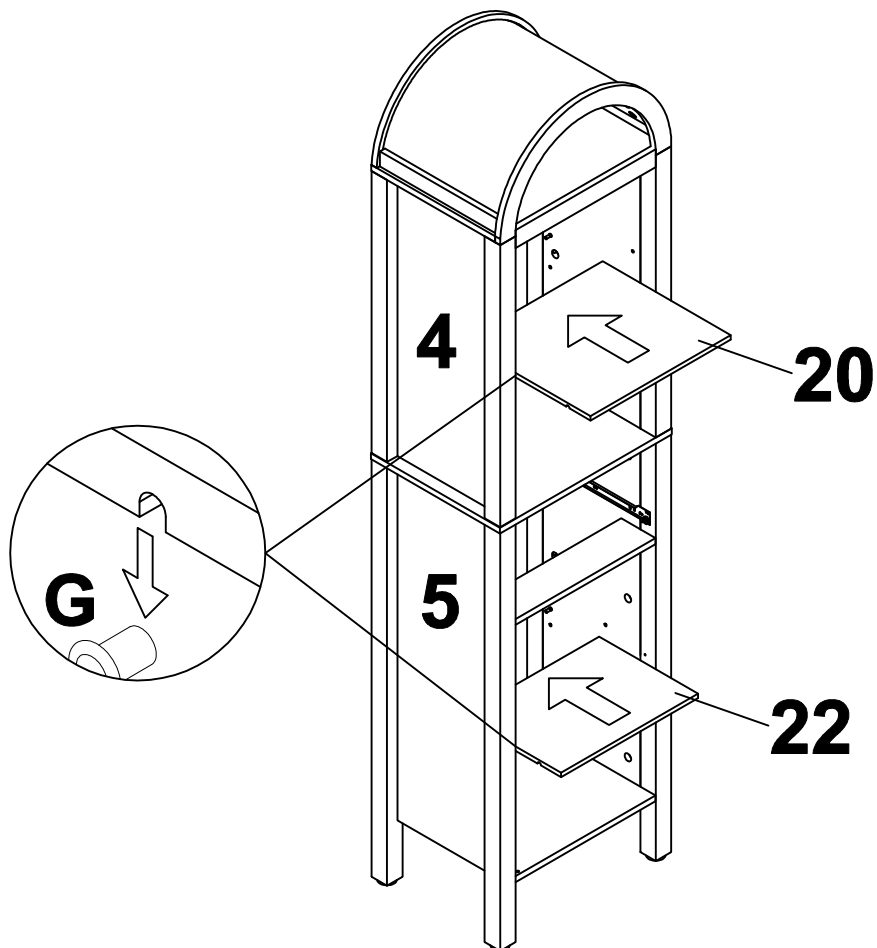

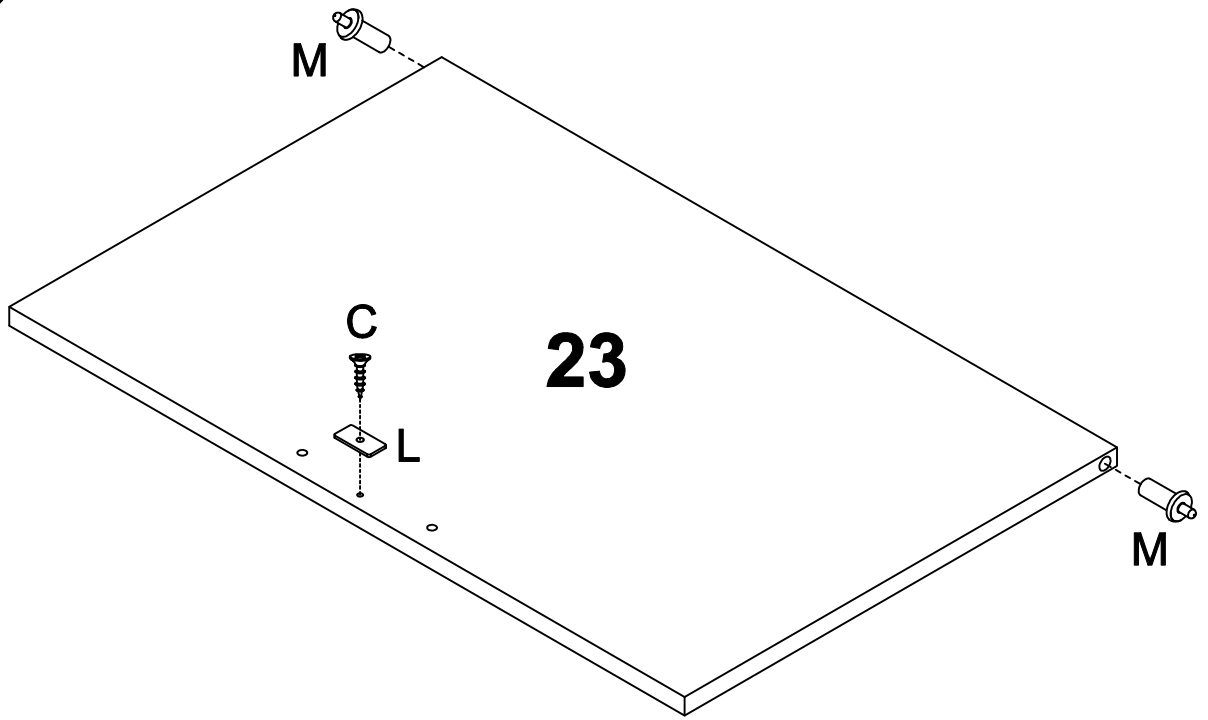

# Step 29

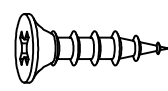
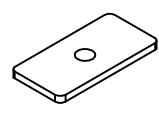
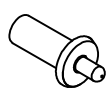

C M3.5x12  x1	L  x1	M  x2
--	---	---

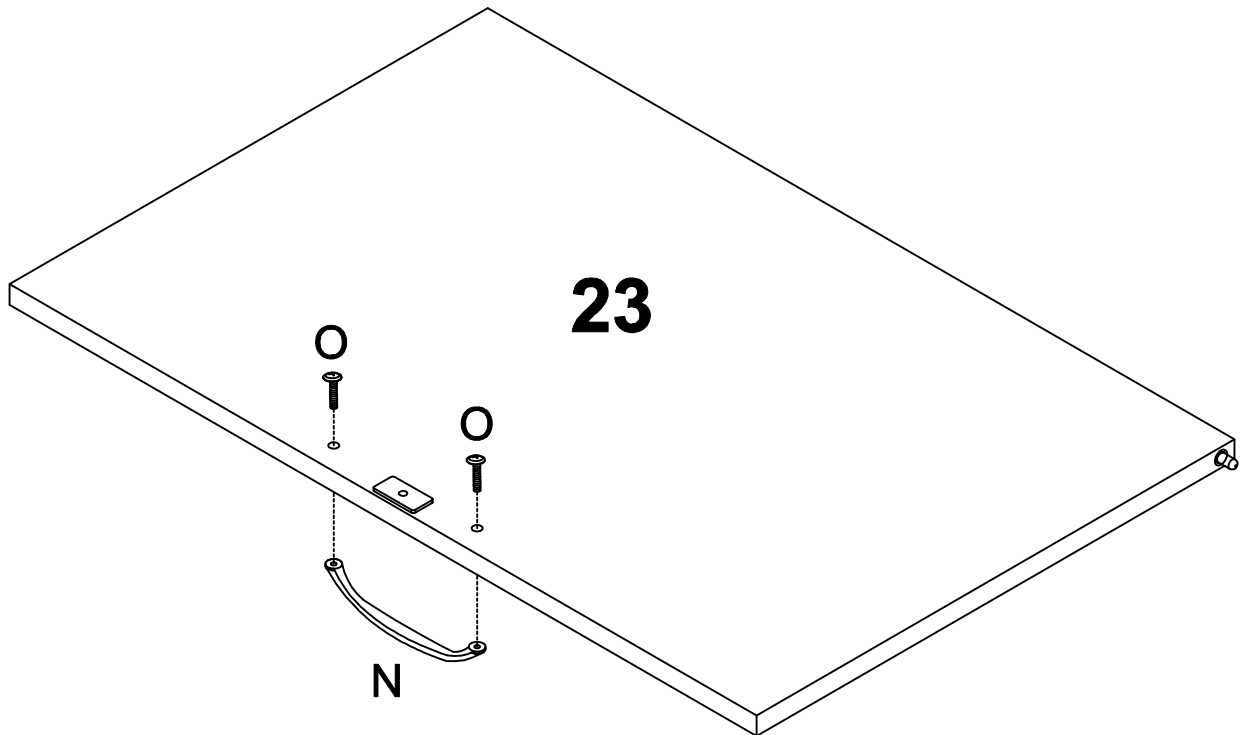
# Step 30

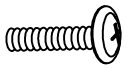

N  x1	O M4x16  x2
--	--

# Step 31

## Option 1

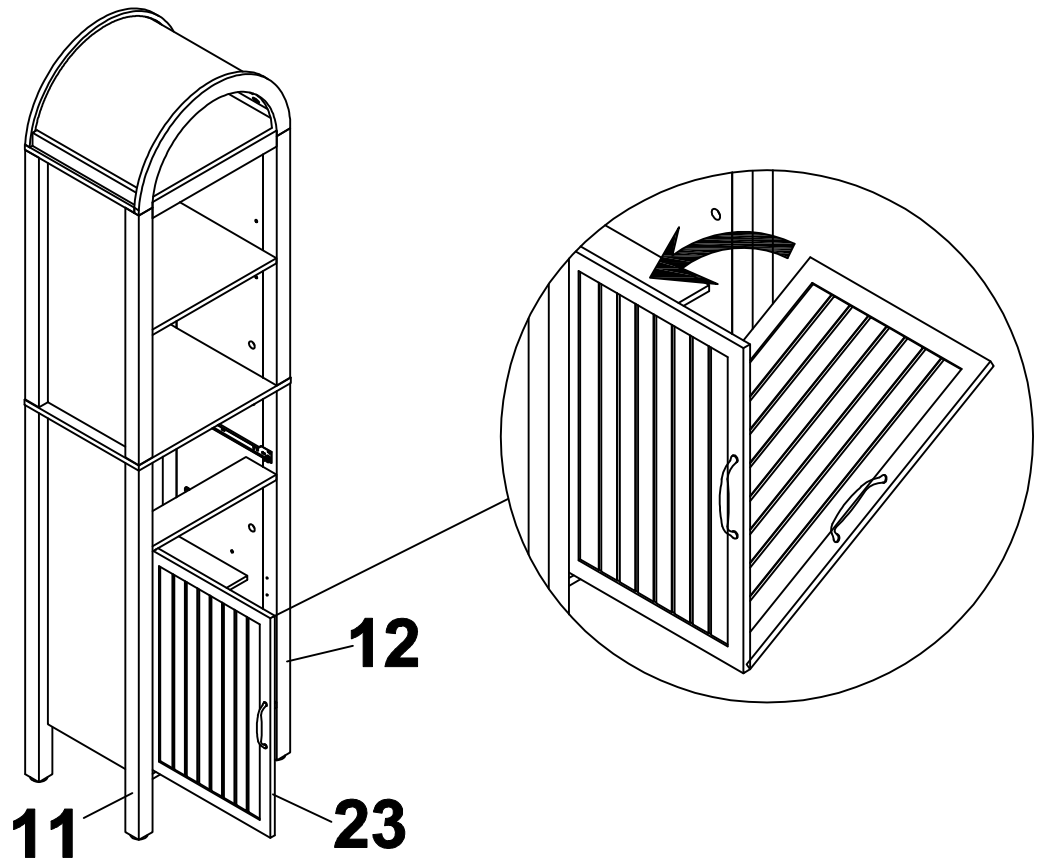

## Option 2

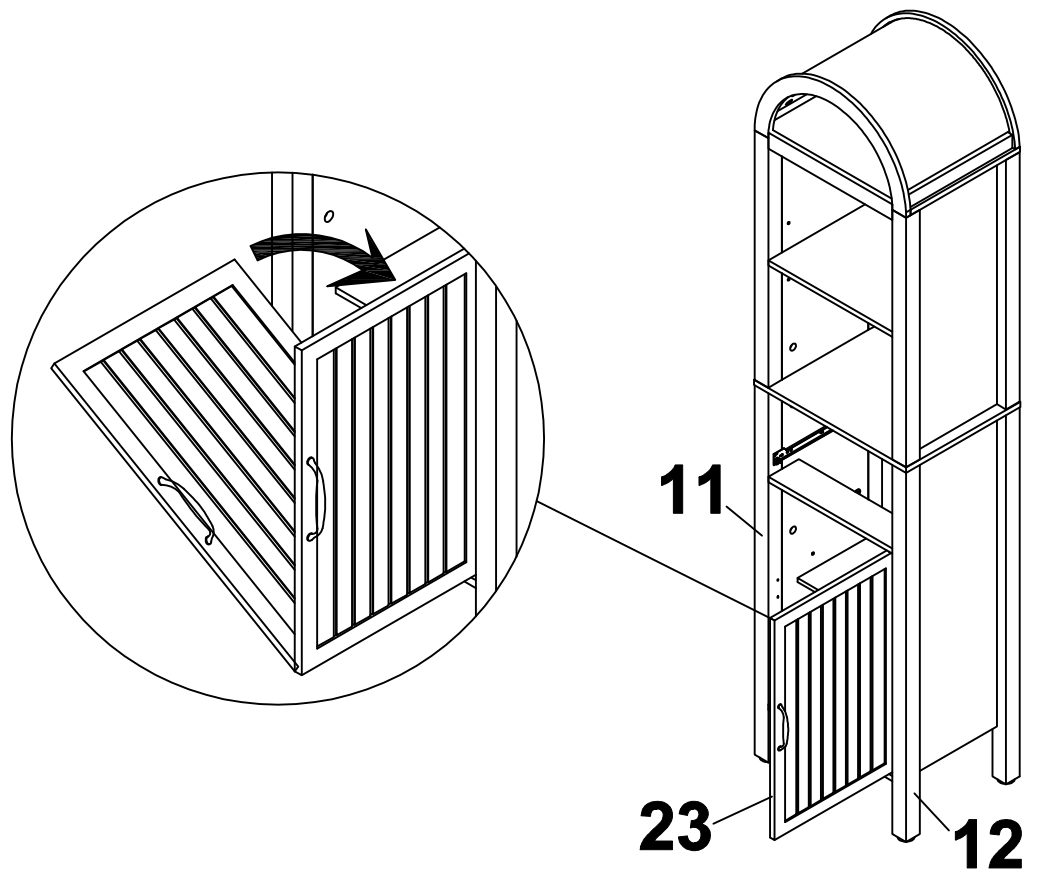

# Step 32

## Option 1

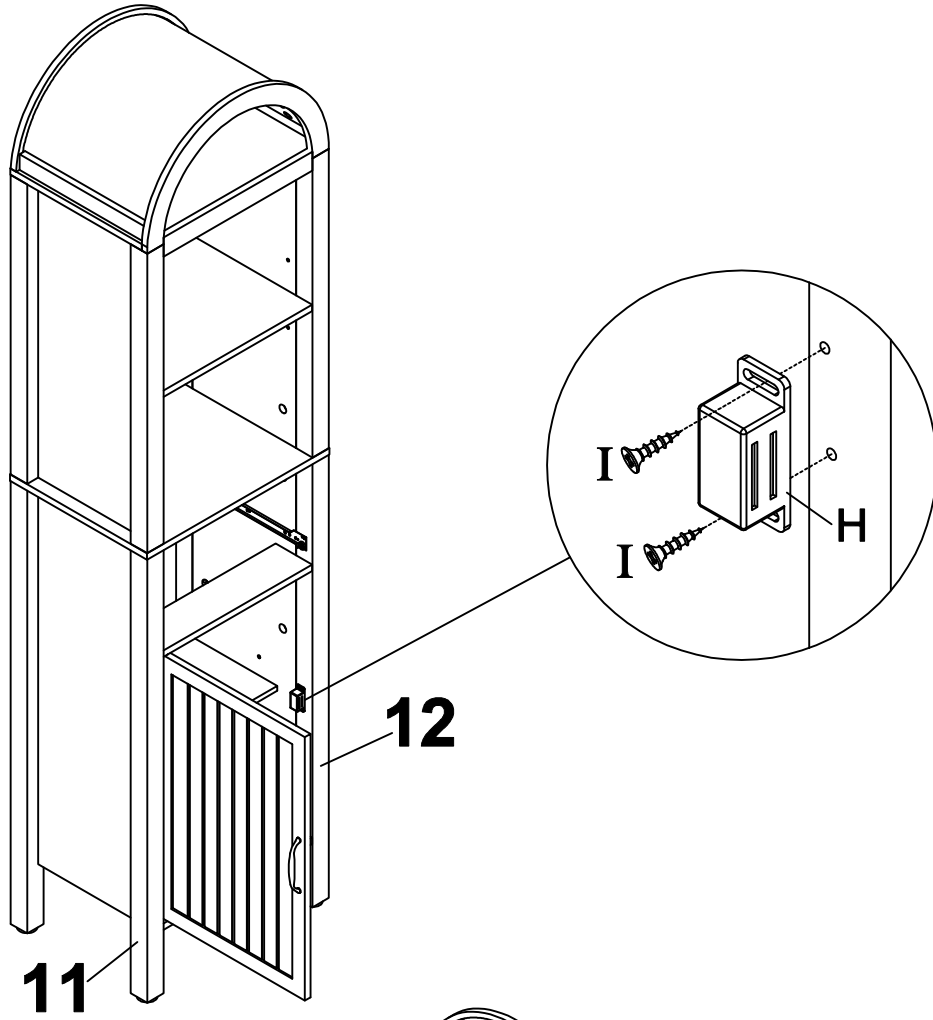

## Option 2

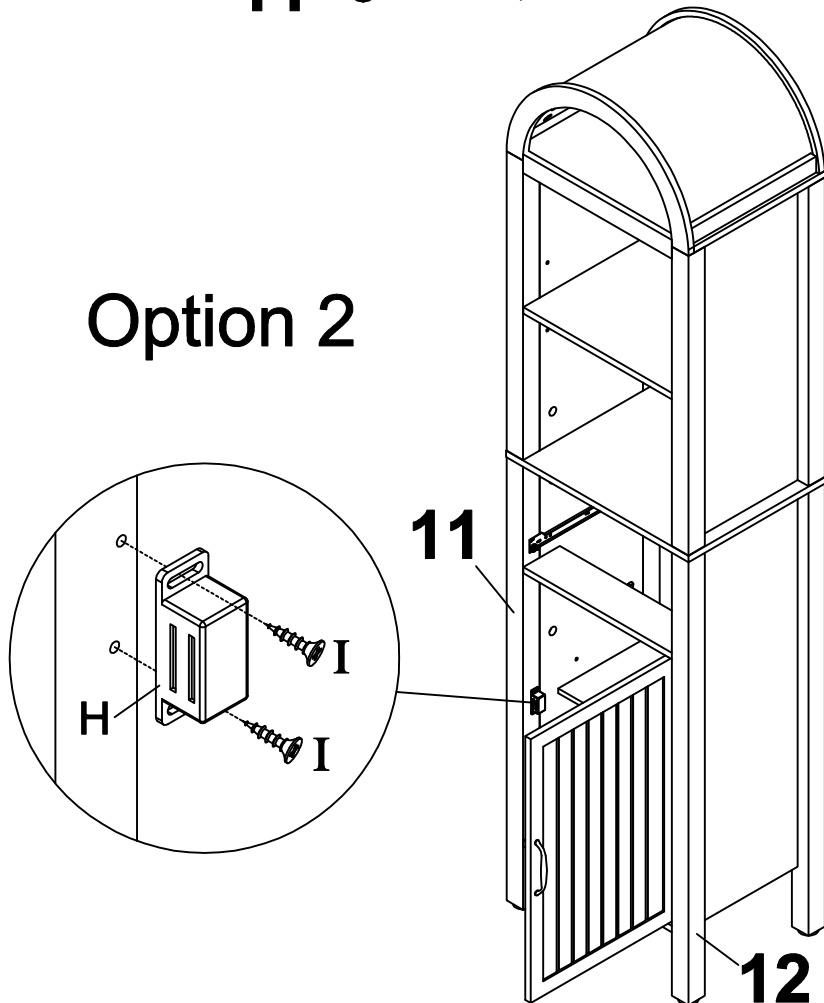

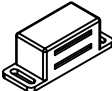
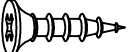
H	I M3x14
	
x1	x2

# Step 33

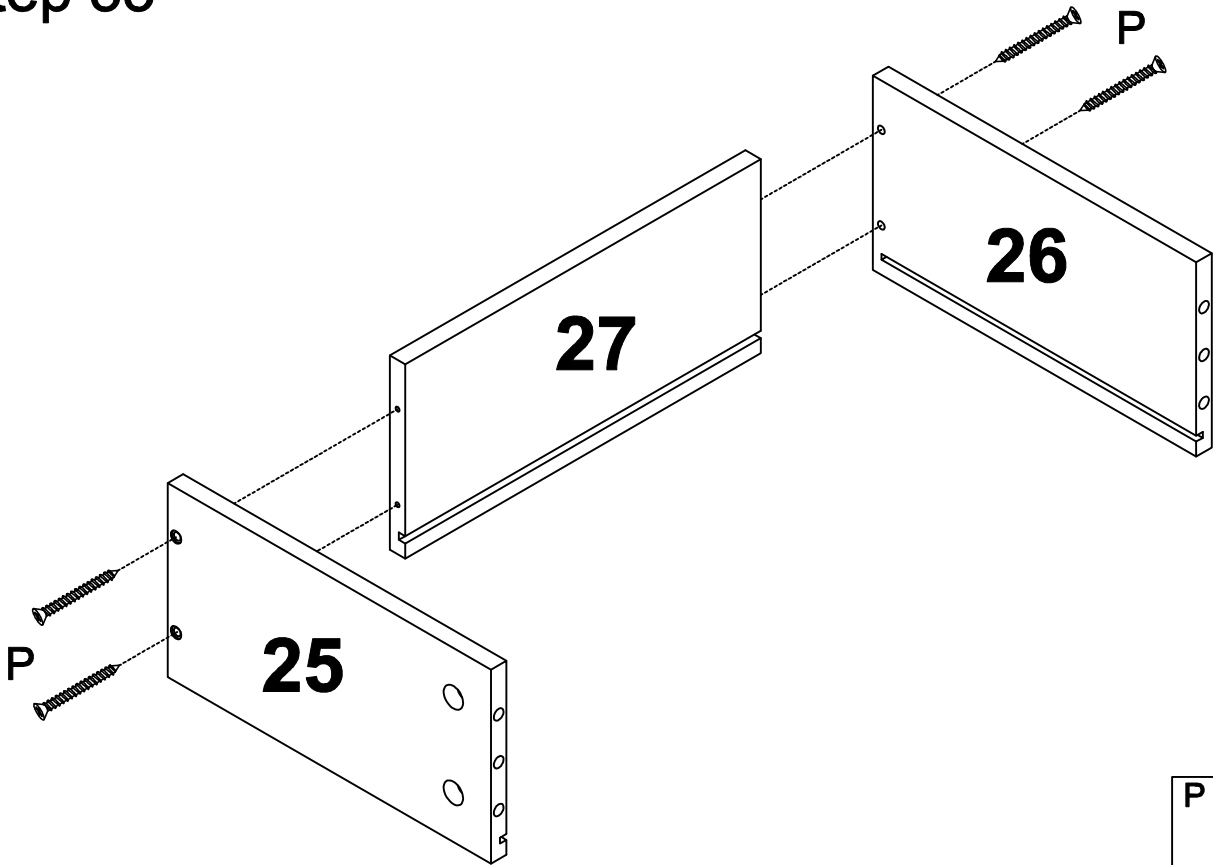

P M3.5x40



x4

# Step 34

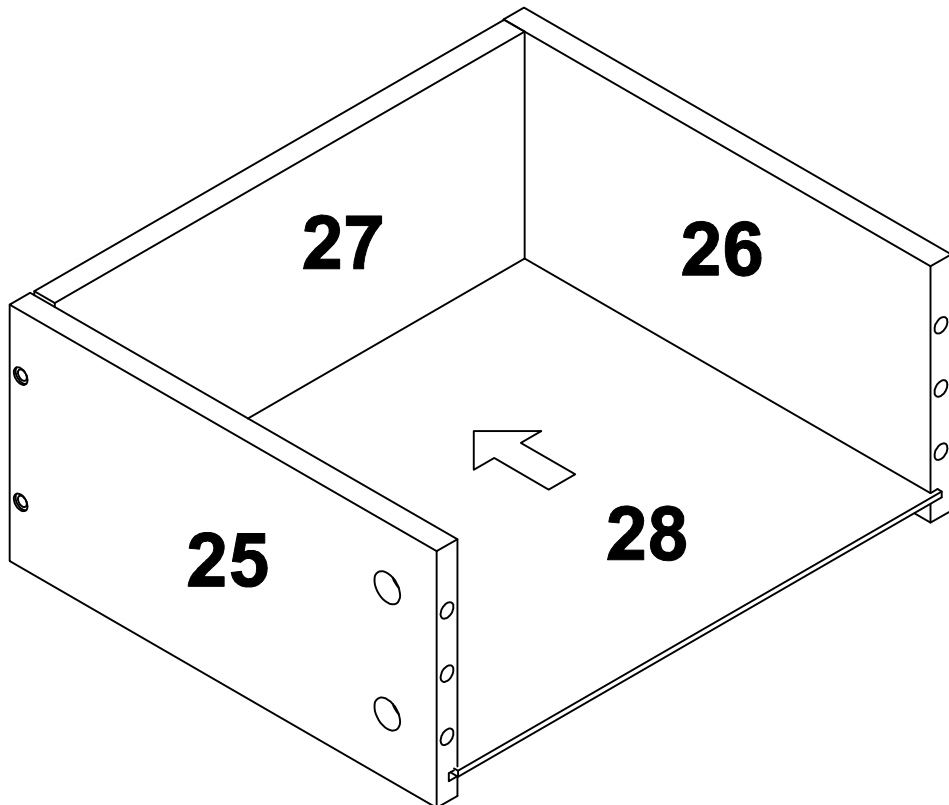

# Step 35

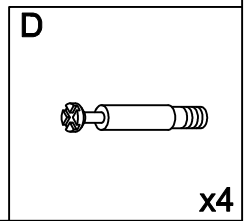
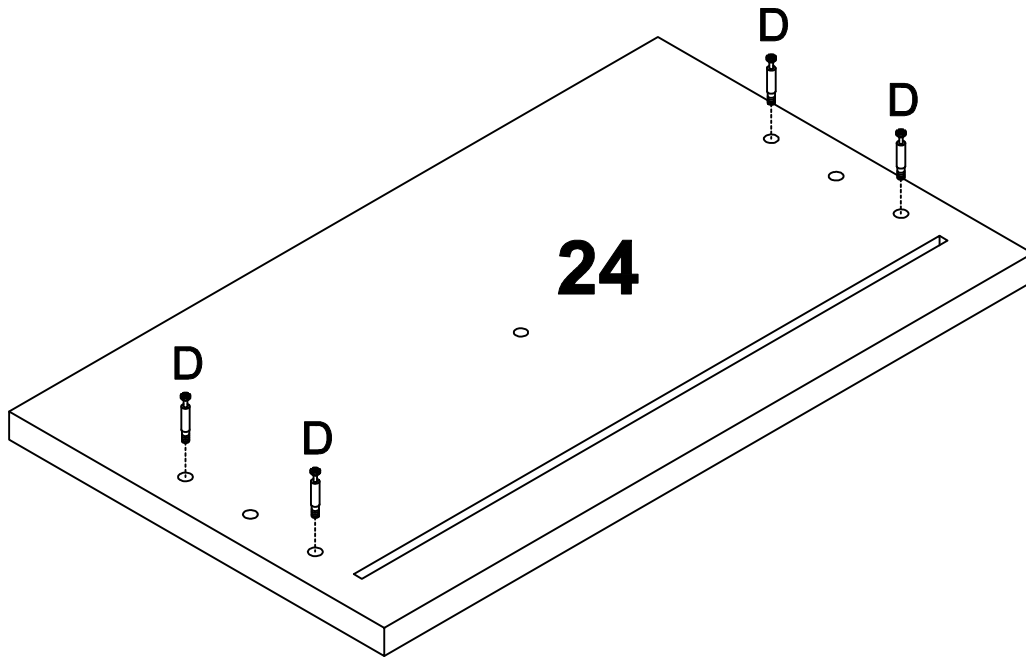

# Step 36

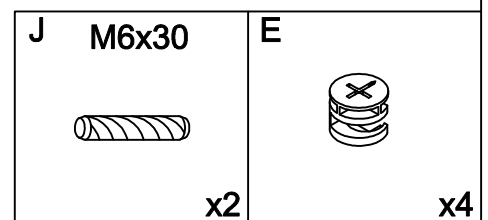
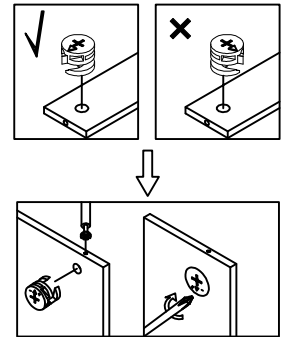
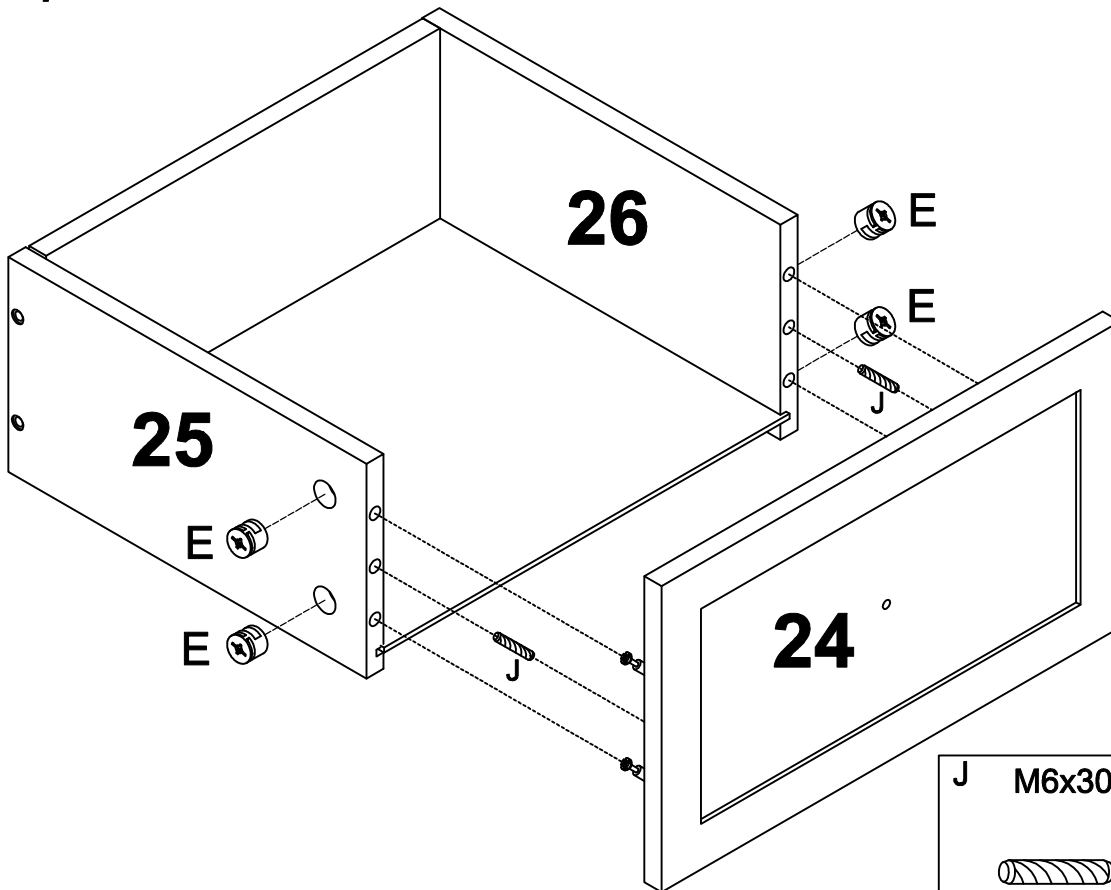

# Step 37

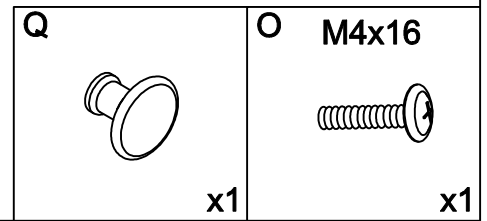
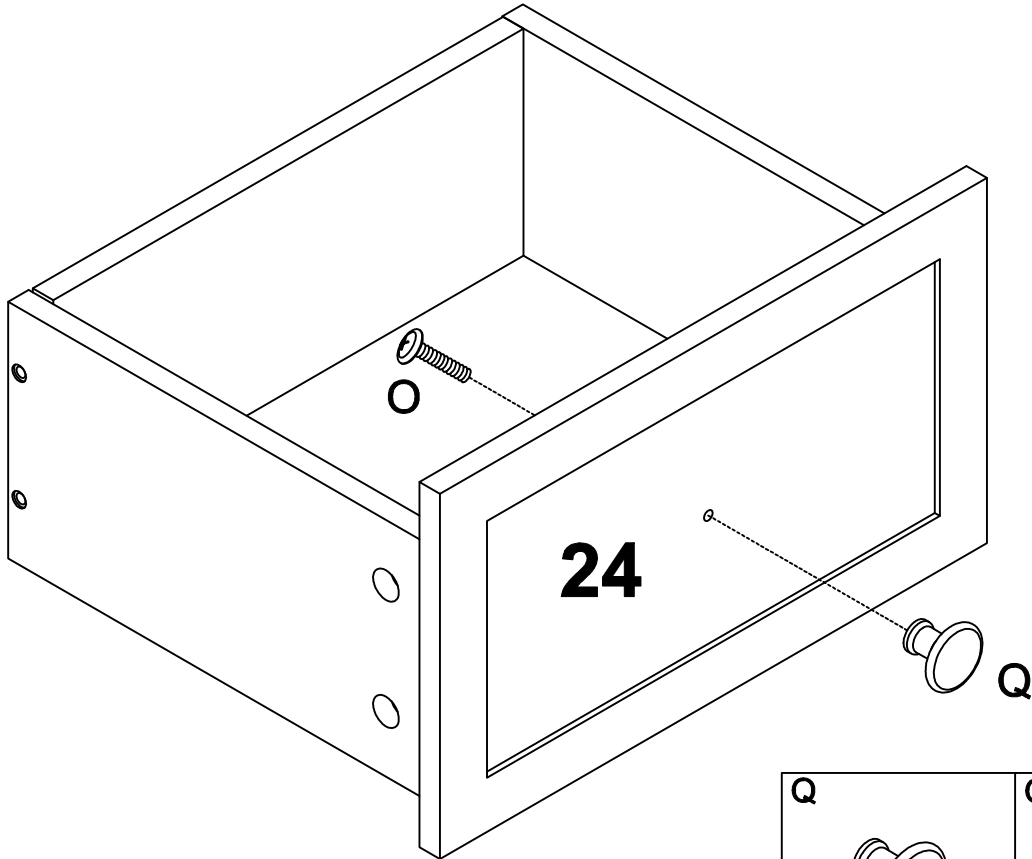

# Step 38

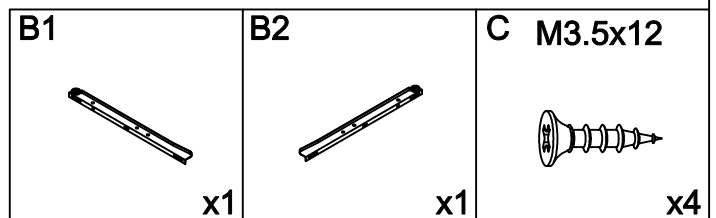
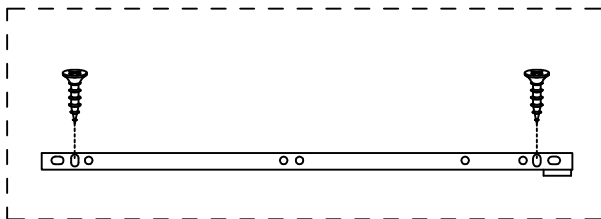
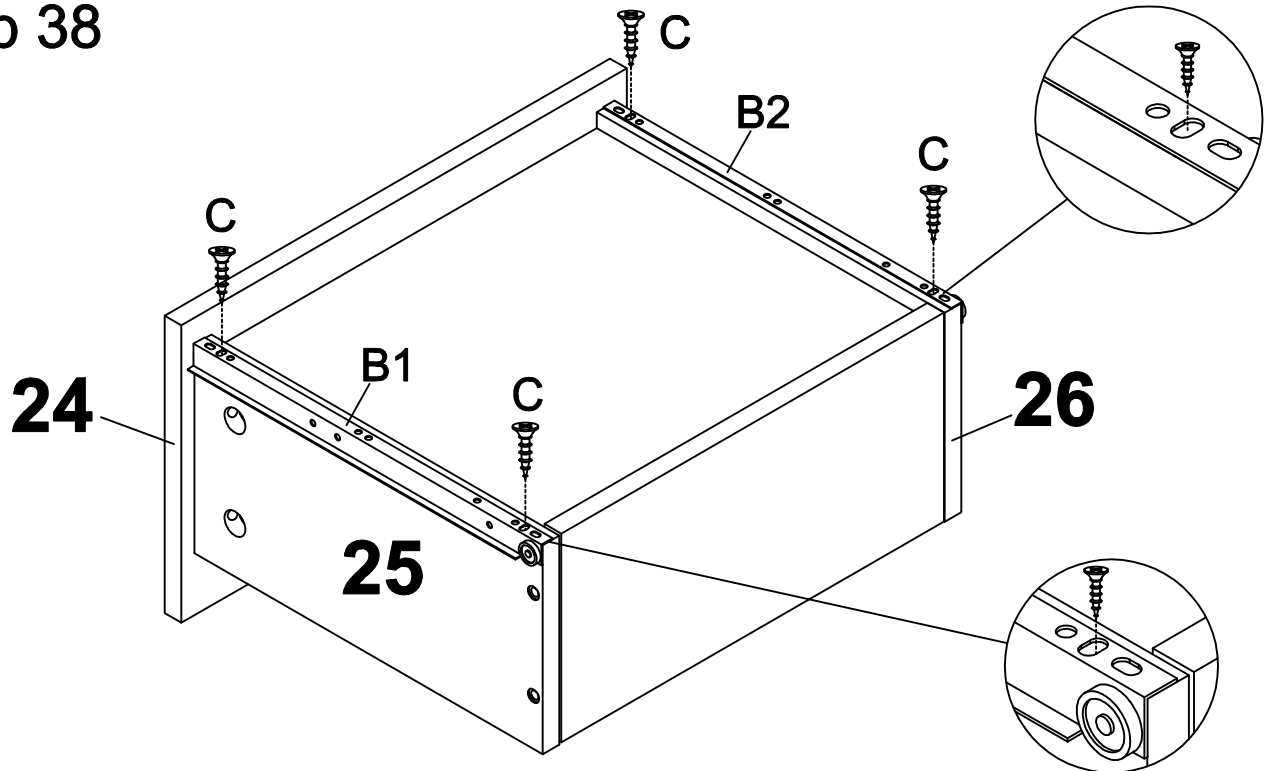

Step 39

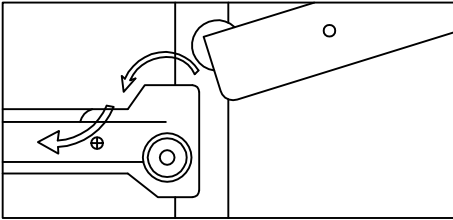
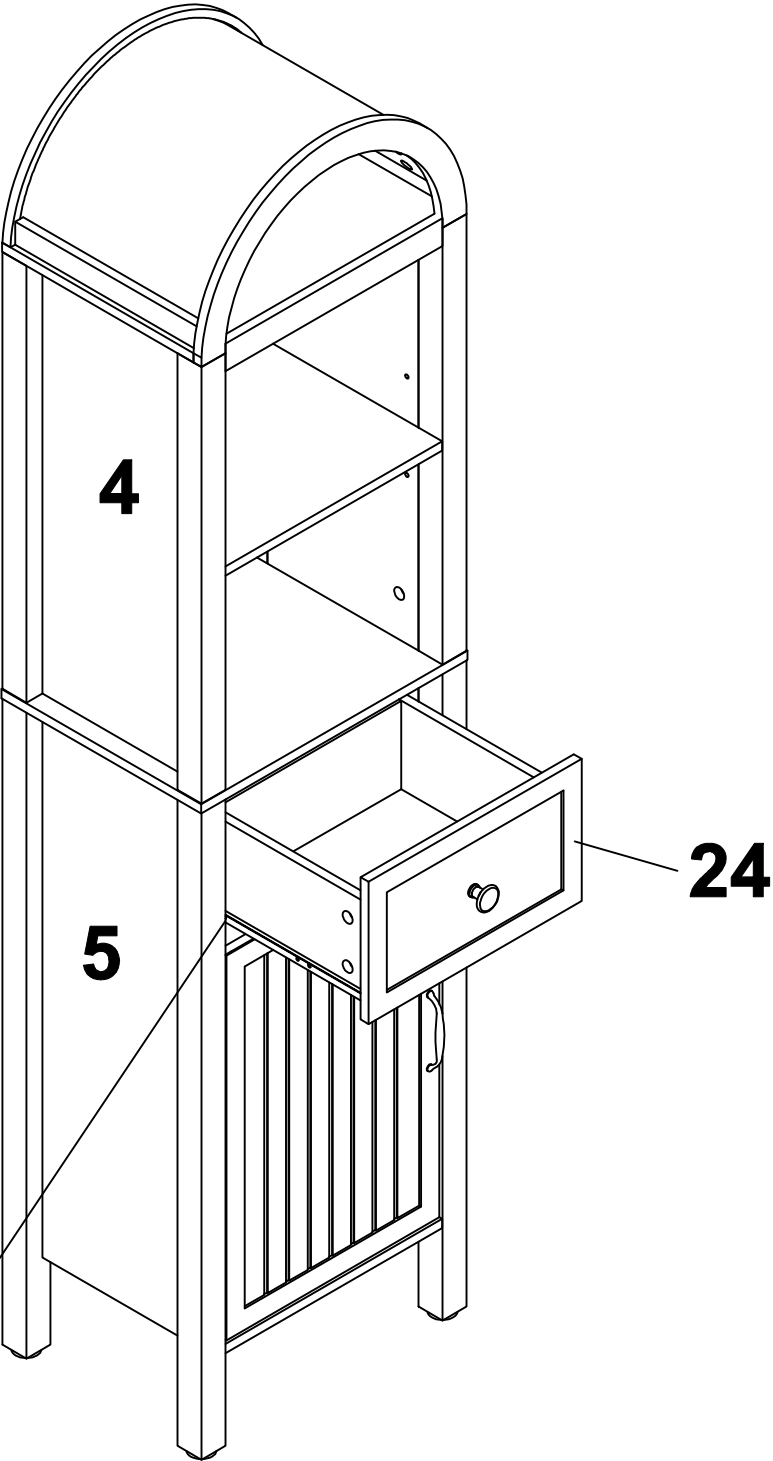

# Step 40

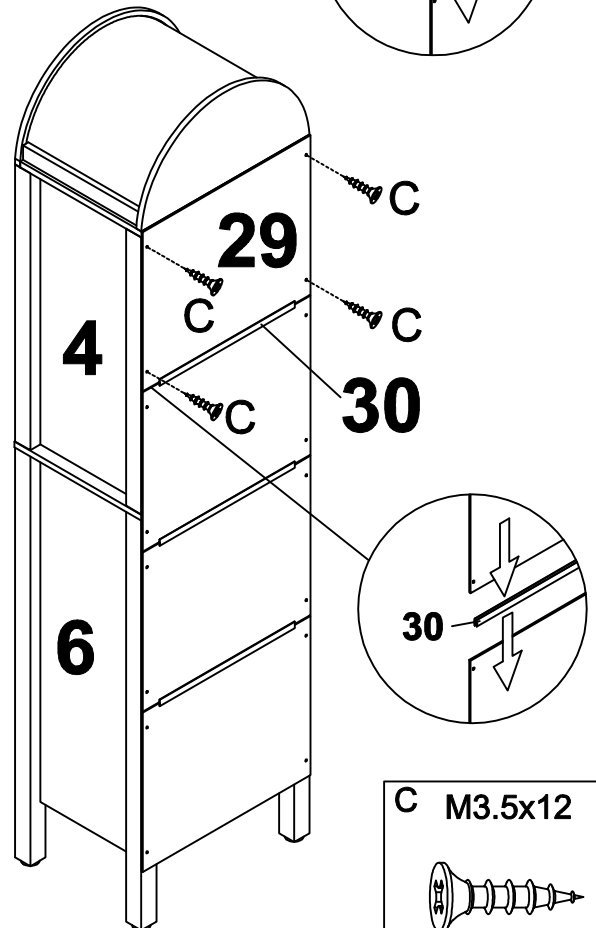
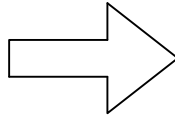
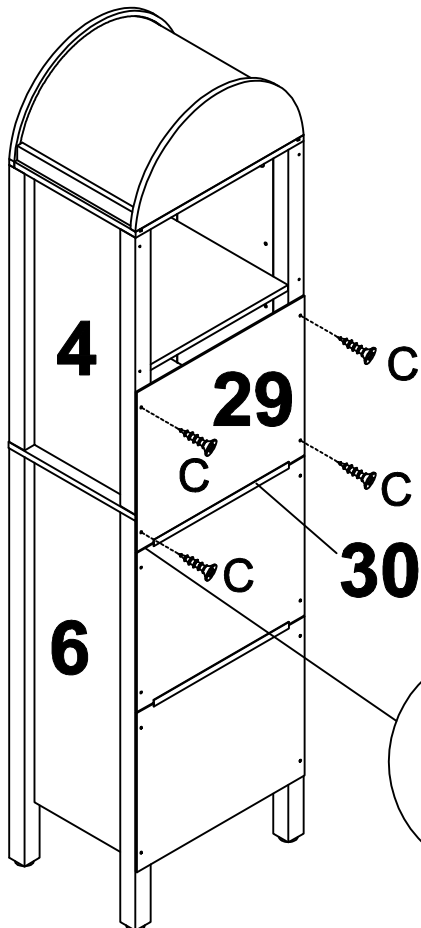
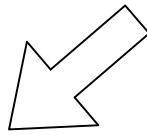
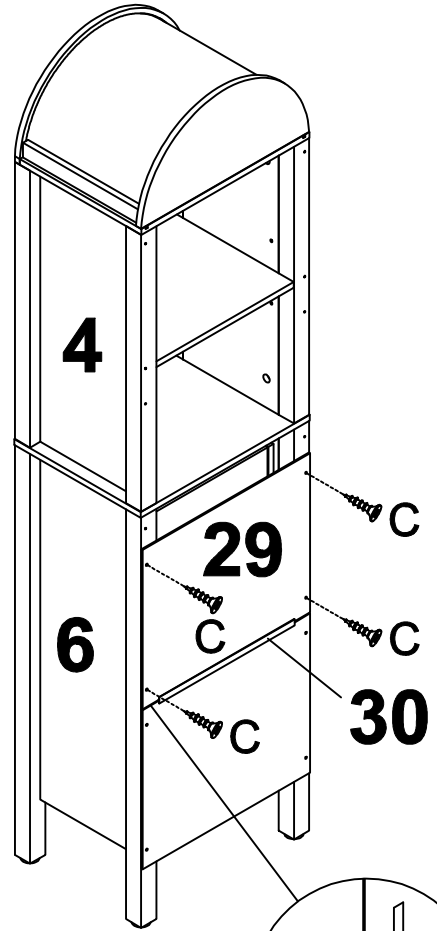
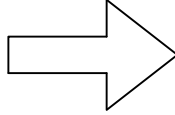
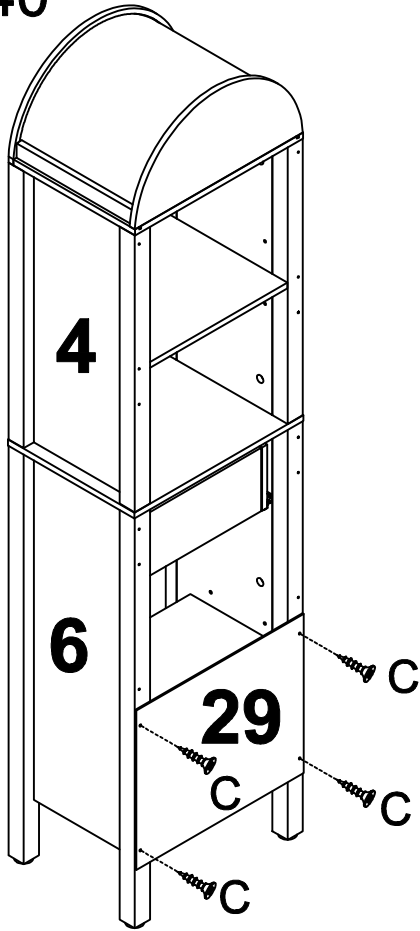

C M3.5x12

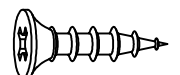

x16

# Step 41

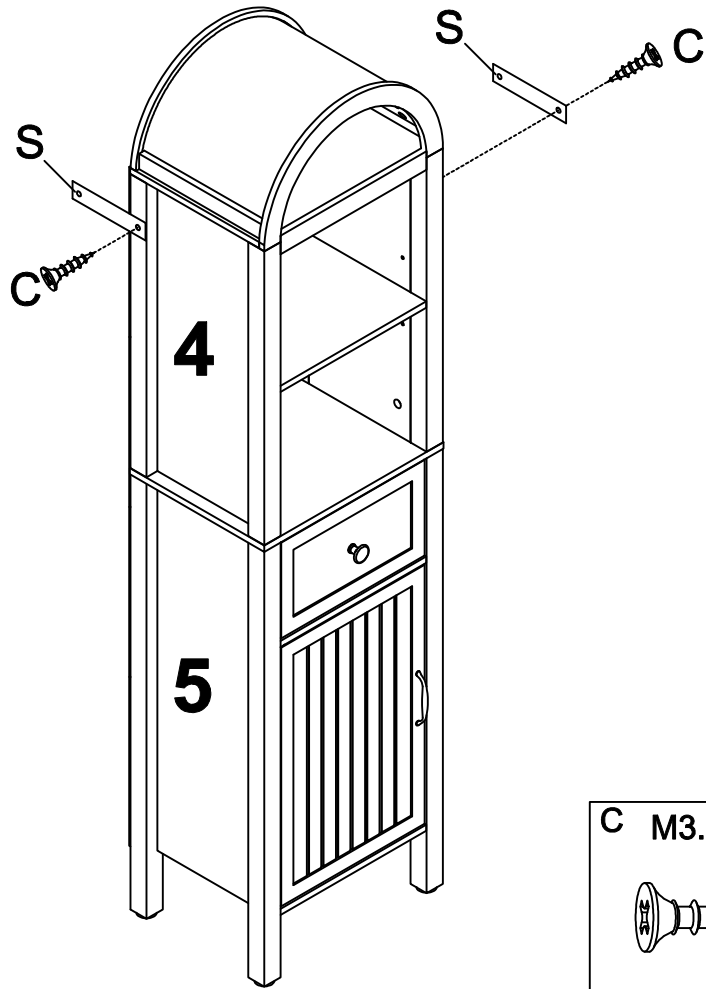

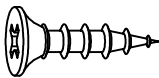
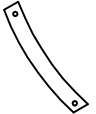
<b>C</b> M3.5x12	<b>S</b>
	
x2	x2

# Step 42

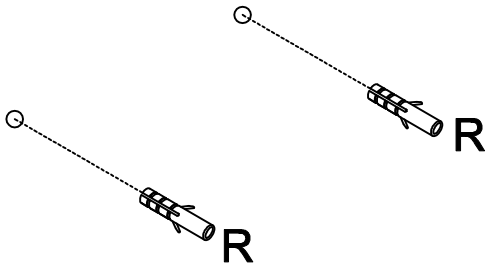

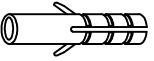
<b>R</b>

x2

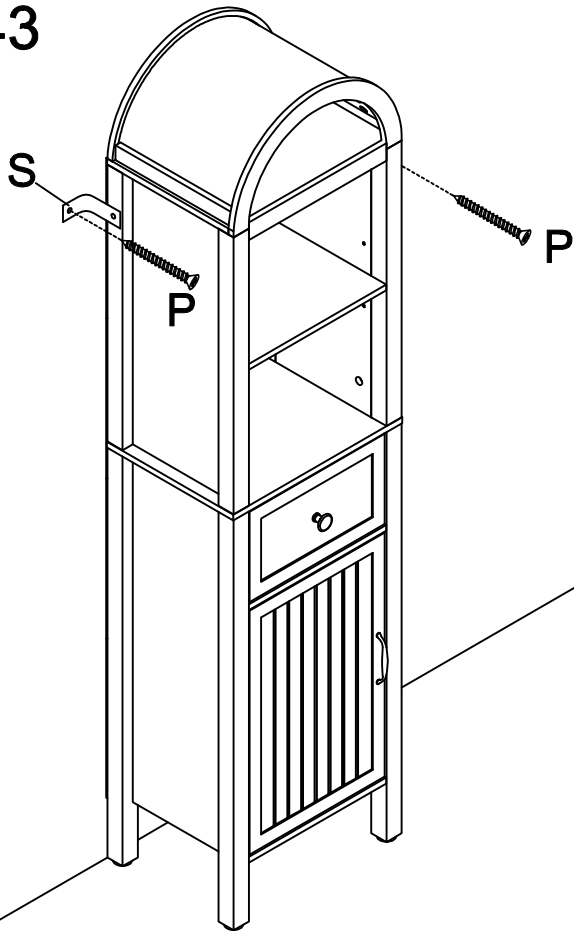
# Step 43



P M3.5x40



x2

# Finish !!!

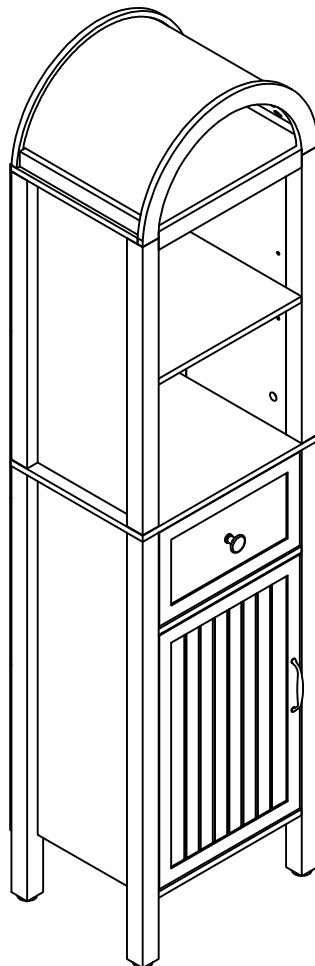

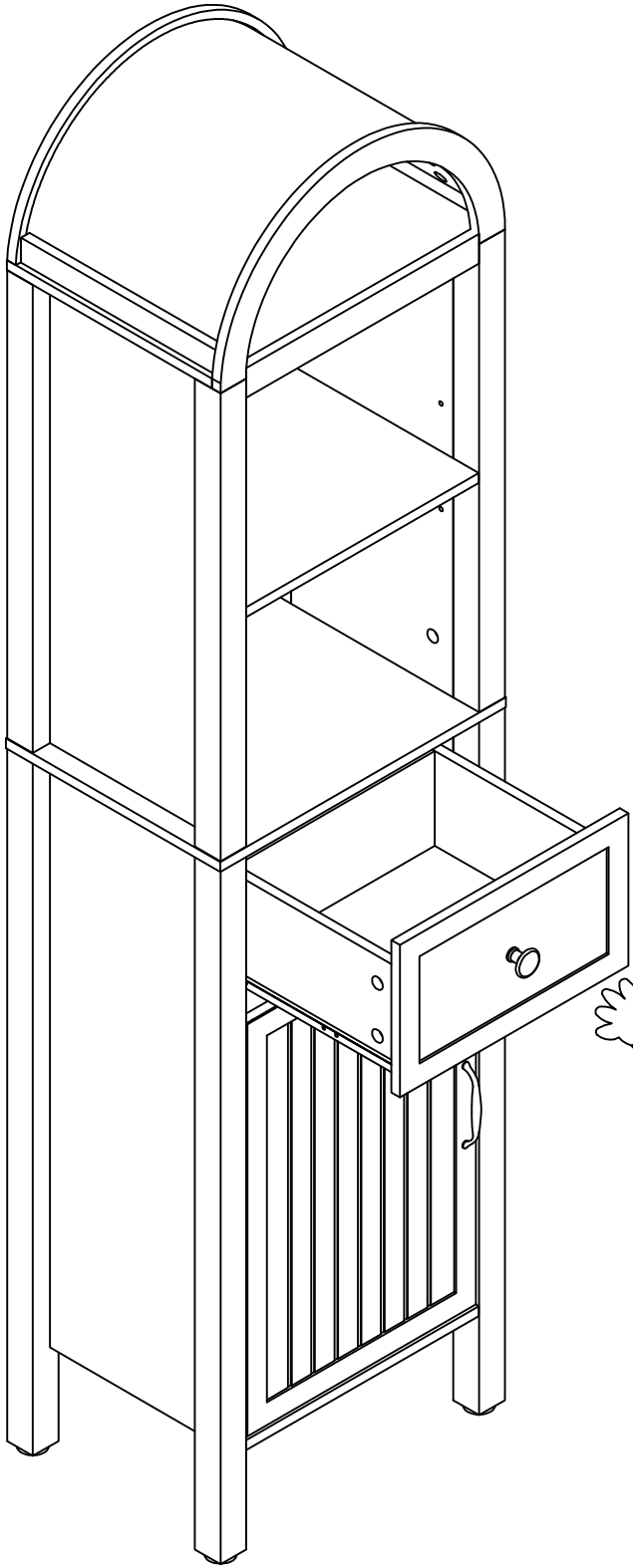

X

