

# ASSEMBLY INSTRUCTIONS

## INSTRUCTIONS DEMONTAGE

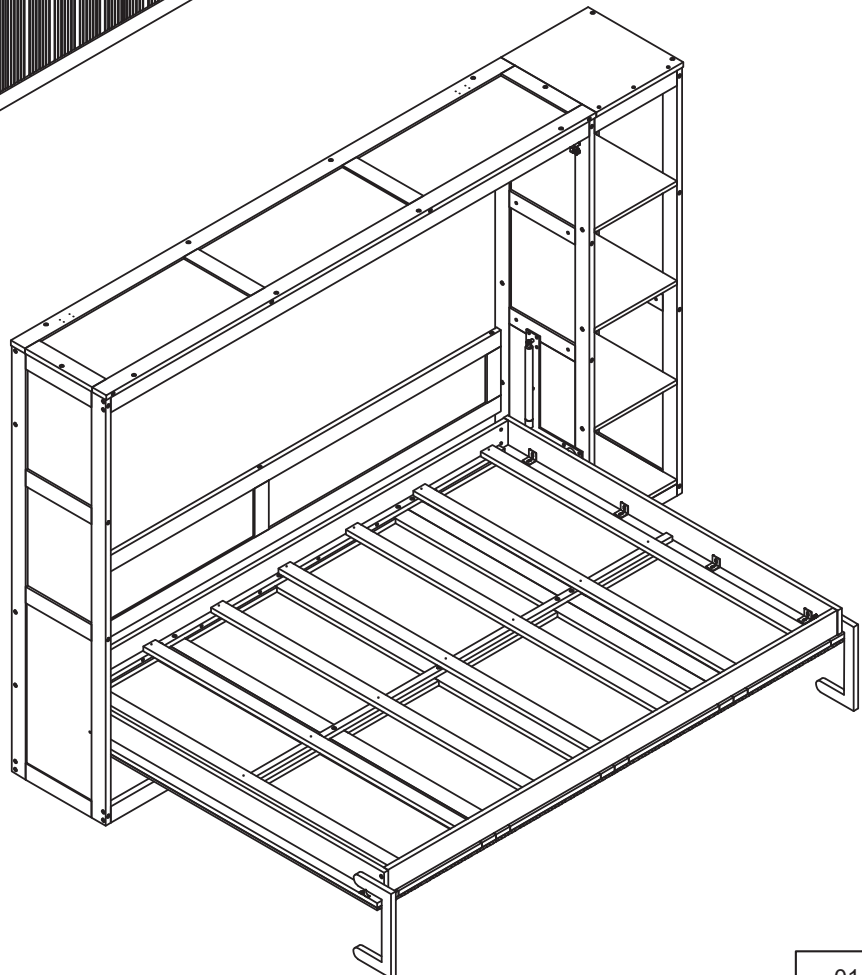

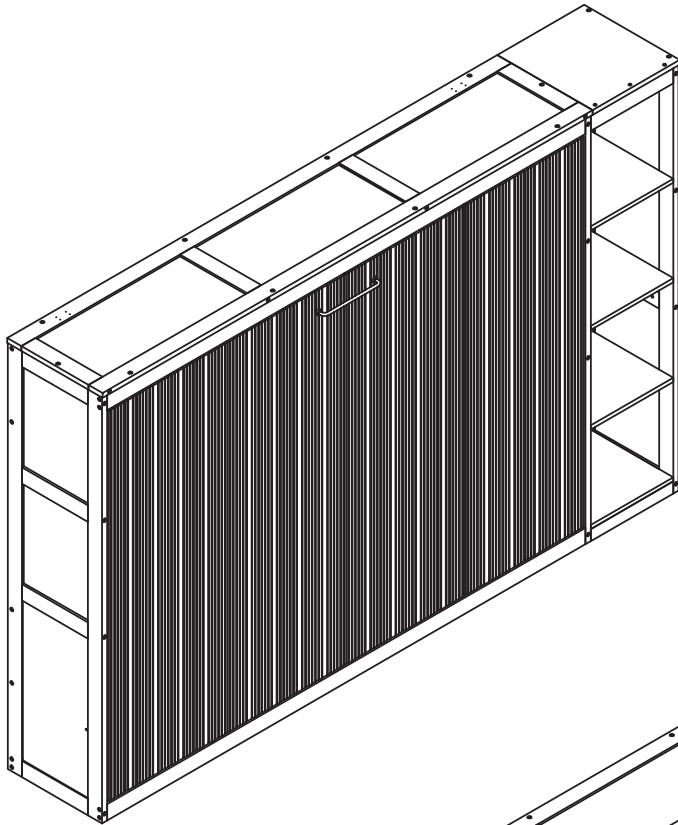
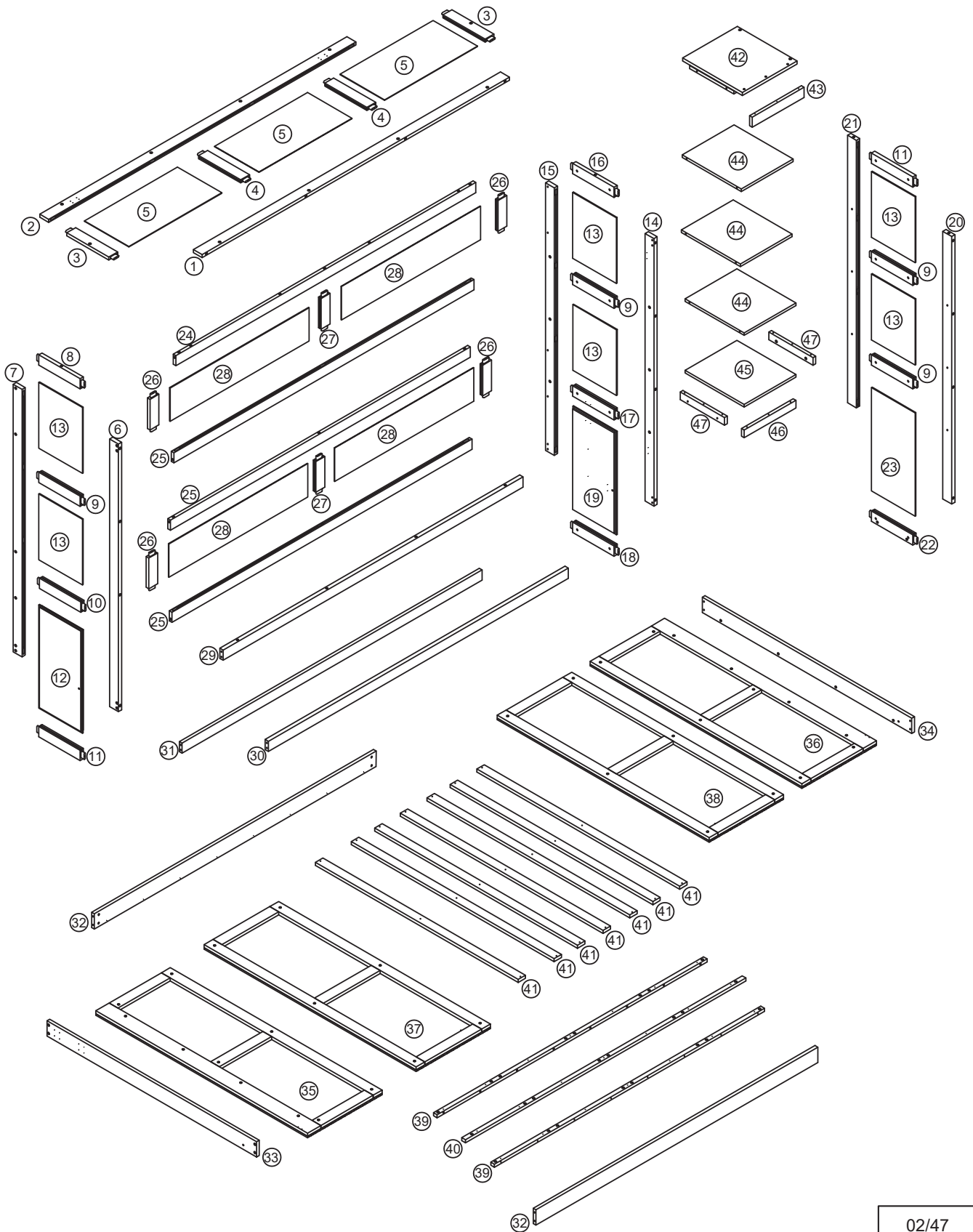

# DETAIL VIEW VUE DÉTAILLÉE

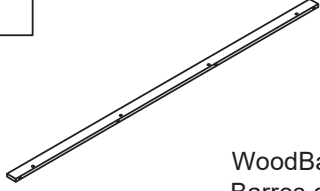
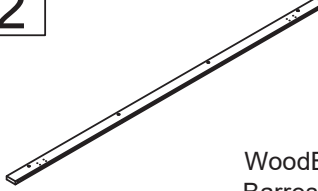
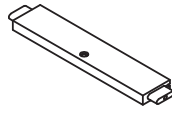
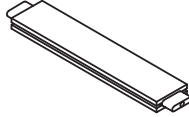
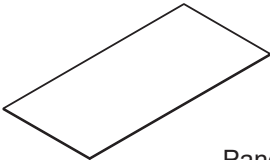
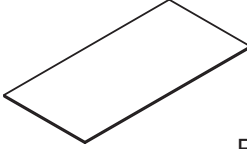
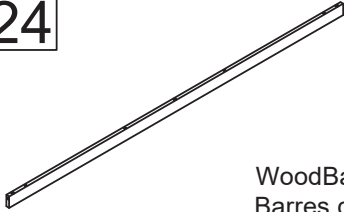

# Part Lists (Box 1)

## Liste des pièces

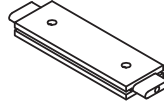
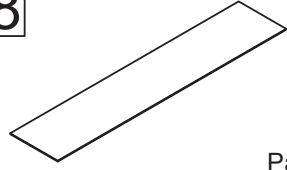
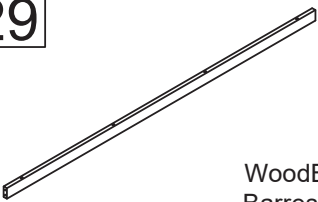
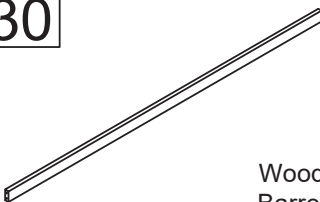
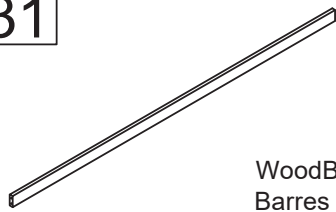
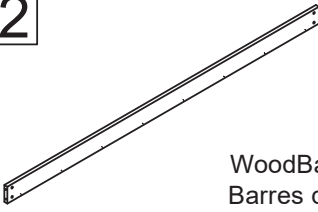
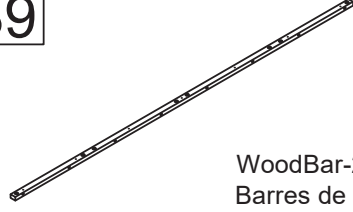
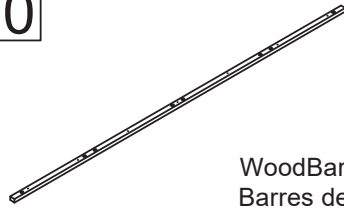
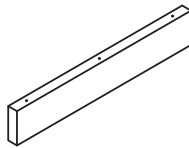
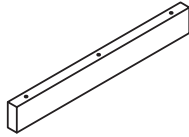
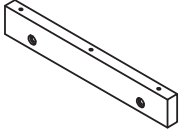
<p><b>1</b></p>  <p>WoodBar-1pc Barres de bois</p>	<p><b>2</b></p>  <p>WoodBar-1pc Barres de bois</p>	<p><b>3</b></p>  <p>WoodBar-2pcs Barres de bois</p>
<p><b>4</b></p>  <p>WoodBar-2pcs Barres de bois</p>	<p><b>5</b></p>  <p>Panel-3pcs Planche</p>	<p><b>23</b></p>  <p>Panel-1pc Planche</p>
<p><b>24</b></p>  <p>WoodBar-1pc Barres de bois</p>	<p><b>25</b></p>  <p>WoodBar-3pcs Barres de bois</p>	<p><b>27</b></p>  <p>WoodBar-2pcs Barres de bois</p>
<p><b>28</b></p>  <p>Panel-4pcs Planche</p>	<p><b>29</b></p>  <p>WoodBar-1pc Barres de bois</p>	<p><b>30</b></p>  <p>WoodBar-1pc Barres de bois</p>
<p><b>31</b></p>  <p>WoodBar-1pc Barres de bois</p>	<p><b>32</b></p>  <p>WoodBar-2pcs Barres de bois</p>	<p><b>39</b></p>  <p>WoodBar-2pcs Barres de bois</p>
<p><b>40</b></p>  <p>WoodBar-1pc Barres de bois</p>	<p><b>43</b></p>  <p>WoodBar-1pc Barres de bois</p>	<p><b>46</b></p>  <p>WoodBar-1pc Barres de bois</p>
<p><b>47</b></p>  <p>WoodBar-2pcs Barres de bois</p>		

# Part Lists (Box 2)

## Liste des pièces

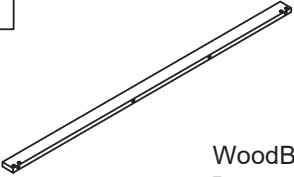
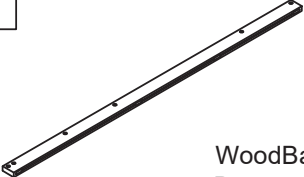
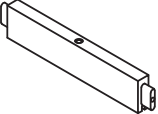
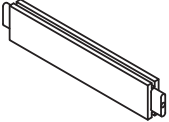
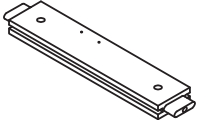
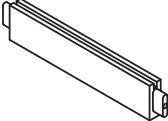
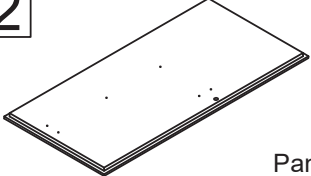
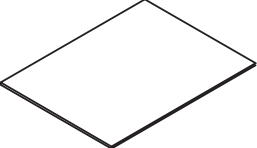
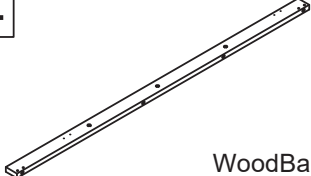
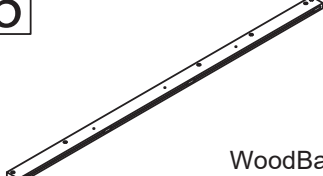
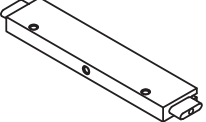
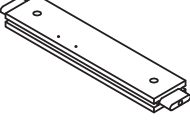
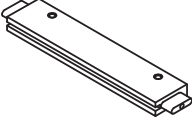
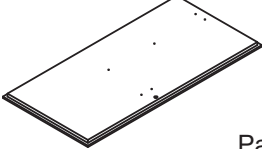
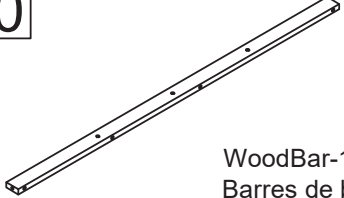
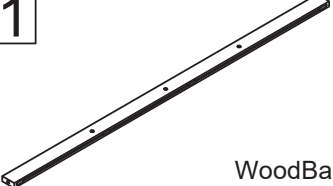
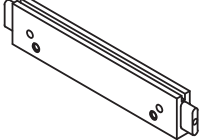
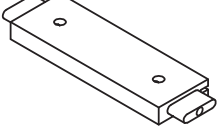
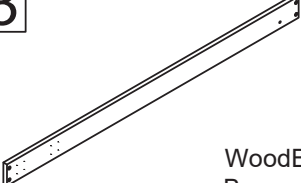
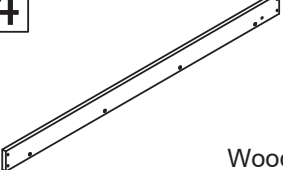
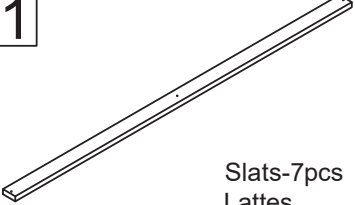
<b>6</b>  WoodBar-1pc Barres de bois	<b>7</b>  WoodBar-1pc Barres de bois	<b>8</b>  WoodBar-1pc Barres de bois
<b>9</b>  WoodBar-4pcs Barres de bois	<b>10</b>  WoodBar-1pc Barres de bois	<b>11</b>  WoodBar-2pcs Barres de bois
<b>12</b>  Panel-1pc Planche	<b>13</b>  Panel-6pcs Planche	<b>14</b>  WoodBar-1pc Barres de bois
<b>15</b>  WoodBar-1pc Barres de bois	<b>16</b>  WoodBar-1pc Barres de bois	<b>17</b>  WoodBar-1pc Barres de bois
<b>18</b>  WoodBar-1pc Barres de bois	<b>19</b>  Panel-1pc Planche	<b>20</b>  WoodBar-1pc Barres de bois
<b>21</b>  WoodBar-1pc Barres de bois	<b>22</b>  WoodBar-1pc Barres de bois	<b>26</b>  WoodBar-4pcs Barres de bois
<b>33</b>  WoodBar-1pc Barres de bois	<b>34</b>  WoodBar-1pc Barres de bois	<b>41</b>  Slats-7pcs Lattes

# Part Lists (Box 2)

## Liste des pièces

42

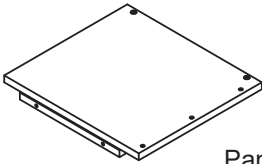

Panel-1pc  
Planche

44

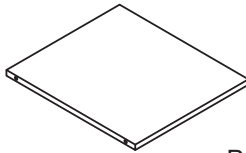

Panel-3pcs  
Planche

45

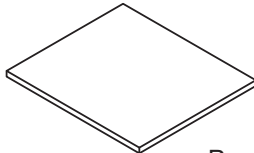

Panel-1pc  
Planche

# Part Lists (Box 3)

## Liste des pièces

35

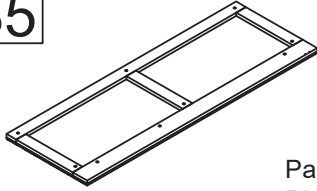

Panel-1pc  
Planche

36

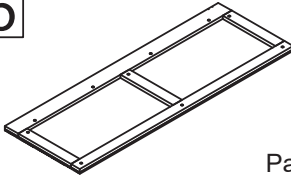

Panel-1pc  
Planche

37

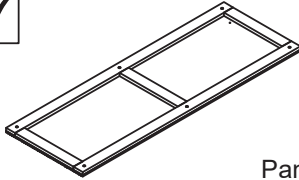

Panel-1pc  
Planche

38

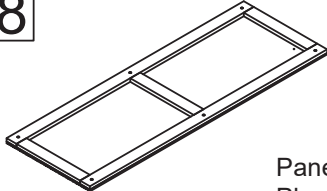

Panel-1pc  
Planche

# Hardware Lists (Box 1)

## Liste du matériel

L



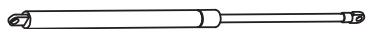









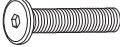



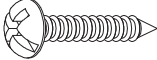







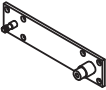

750N

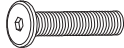

Piston steam (2pcs)  
Vapeur à piston

# Hardware Lists (Box 2)

## Liste du matériel

<b>A1</b>  <p>Ø1/4*110mm</p>	<b>A2</b>  <p>Ø1/4*60mm</p>	<b>A3</b>  <p>Ø1/4*30mm</p>
Hex-Head bolt (44pcs) Boulon	Hex-Head bolt (32pcs) Boulon	Hex-Head bolt (50pcs) Boulon
<b>A4</b>  <p>Ø1/4*12mm</p>	<b>B1</b>  <p>Ø1/4**9.5*13mm</p>	<b>B2</b>  <p>Ø1/4**9.5*10mm</p>
Hex-Head bolt (16pcs) Boulon	Horizontal-Hole bolt (64pcs) Boulons à trou horizontal	Horizontal-Hole bolt (12pcs) Boulons à trou horizontal
<b>C1</b>  <p>Ø4*50mm</p>	<b>C2</b>  <p>Ø4*35mm</p>	<b>C3</b>  <p>Ø4*30mm</p>
Wood screws (9pcs) Vis	Wood screws (37pcs) Vis	Wood screws (3pcs) Vis
<b>D</b> 	<b>E</b>  <p>Ø4*12mm</p>	<b>F1</b> 
Handle (1pc) Poignée	Handle Screws (2pcs) Vis poignée	Metal leg (L) (1pcs) Pied en métal (L)
<b>F2</b> 	<b>G</b> 	<b>H</b>  <p>Ø19/Ø8*2mm</p>
Metal leg (R) (1pc) Pied en métal (R)	Nut (6pcs) Écrou hexagonal	Spring washer (2pcs) Rondelle
<b>I1</b> 	<b>I2</b> 	<b>J</b> 
Metal corner link (L) (1pc) Liens d'angle en métal(L)	Metal corner link (R) (1pc) Liens d'angle en métal(R)	Metal corner link (2pcs) Liens d'angle en métal
<b>K</b> 	<b>M</b>  <p>M8*40mm</p>	<b>N</b>  <p>Ø3.5*15mm</p>
Bearings (2pcs) Roulements(L)	Hex-Head bolt (2pcs) Boulon	Wood screws (36pcs) Vis
<b>O1</b> 	<b>O2</b> 	<b>P</b> 
Angle metal (8pcs) Cornière en métal	Angle metal (2pcs) Cornière en métal	Expansion screw bolts (4sets) Boulons à vis d'expansion
<b>Q</b>  <p>Ø4*15mm</p>	<b>R</b> 	<b>S</b>  <p>Ø3*15mm</p>
Wood screws (8pcs) Vis	Double Roller Catch (2sets) Cierre De Doble Rodillo	Wood screws (8pcs) Vis
		08/47

# Hardware Lists (Box 2)

## Liste du matériel

T



Open wrench 13mm (1pcs)  
Clé plate 13mm

U





K4mm

Allen key (2pcs)  
Clé Allen

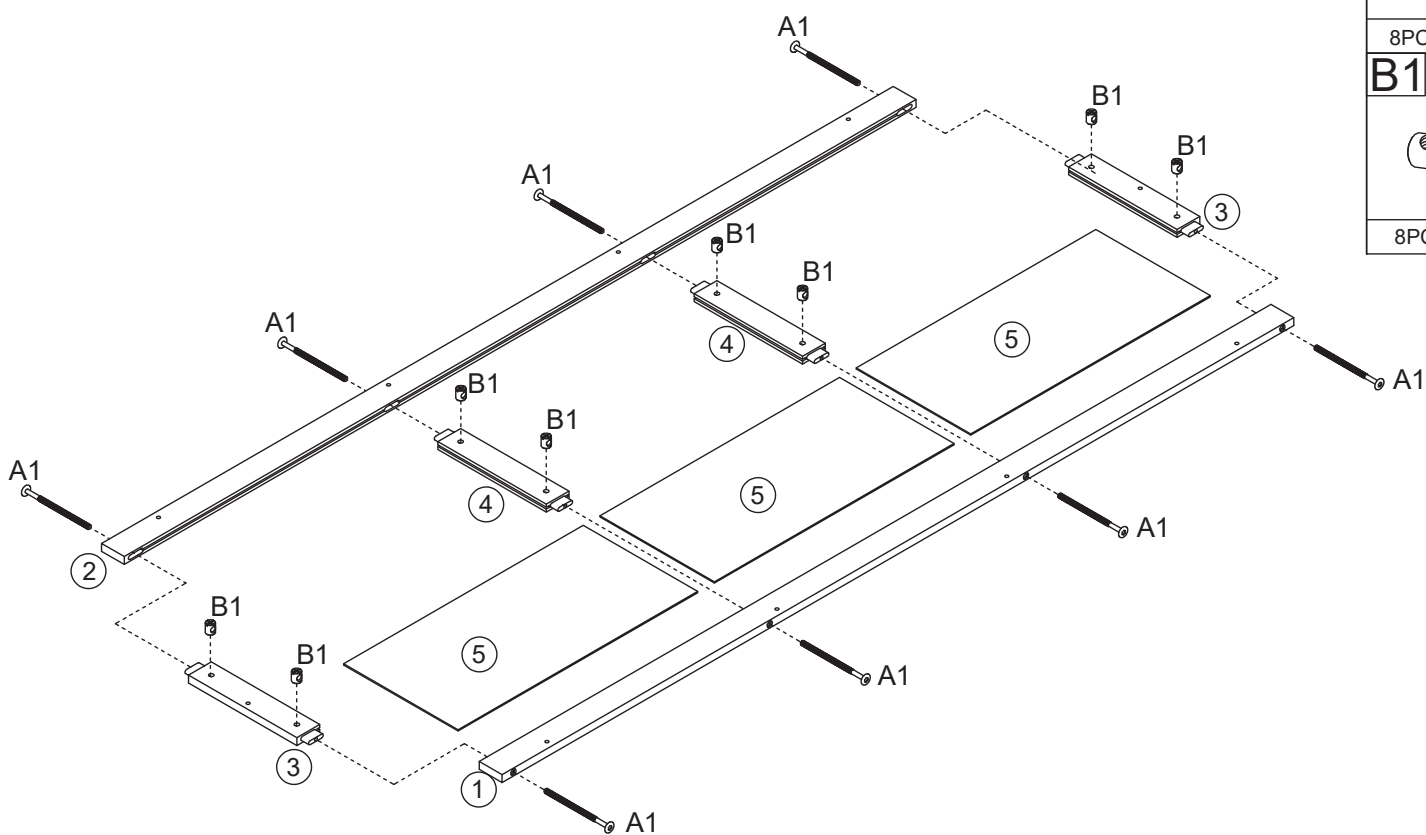

**Step 1**  
**Étape 1**



<b>A1</b>	
8PCS	
<b>B1</b>	
8PCS	

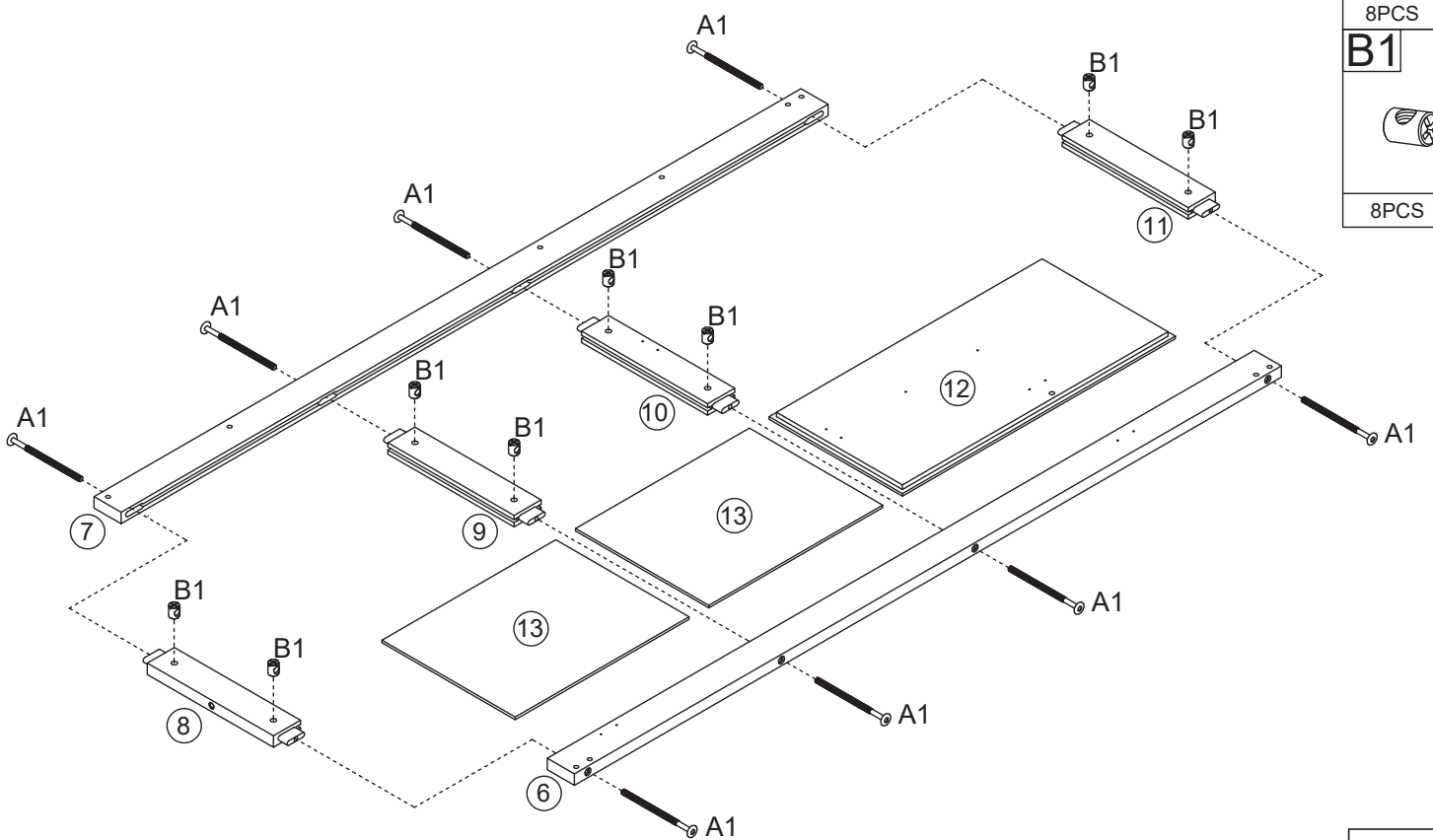

Step 2  
Étape 2



A1	
8PCS	
B1	
8PCS	

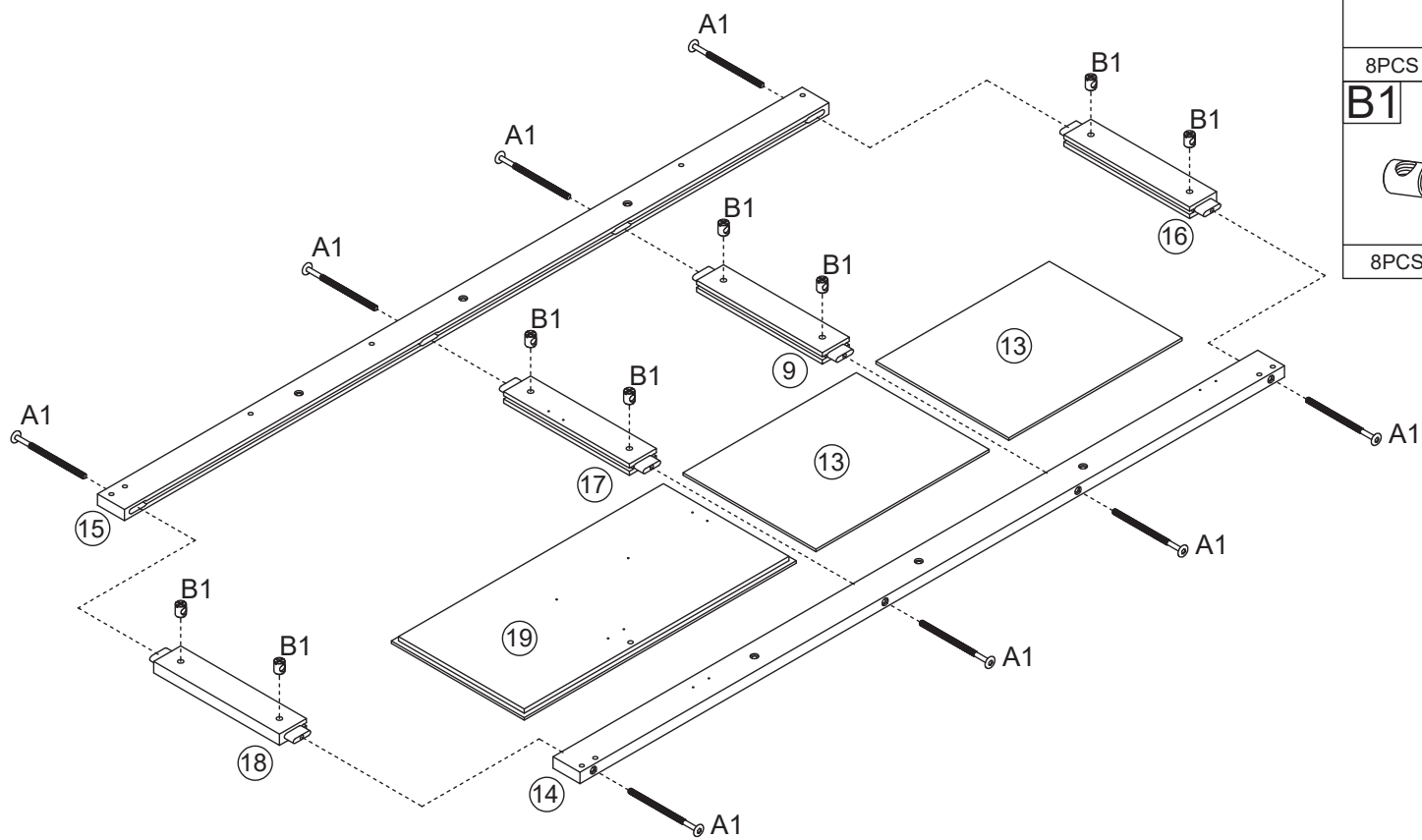

**Step 3**  
**Étape 3**



<b>A1</b>	
8PCS	
<b>B1</b>	
8PCS	

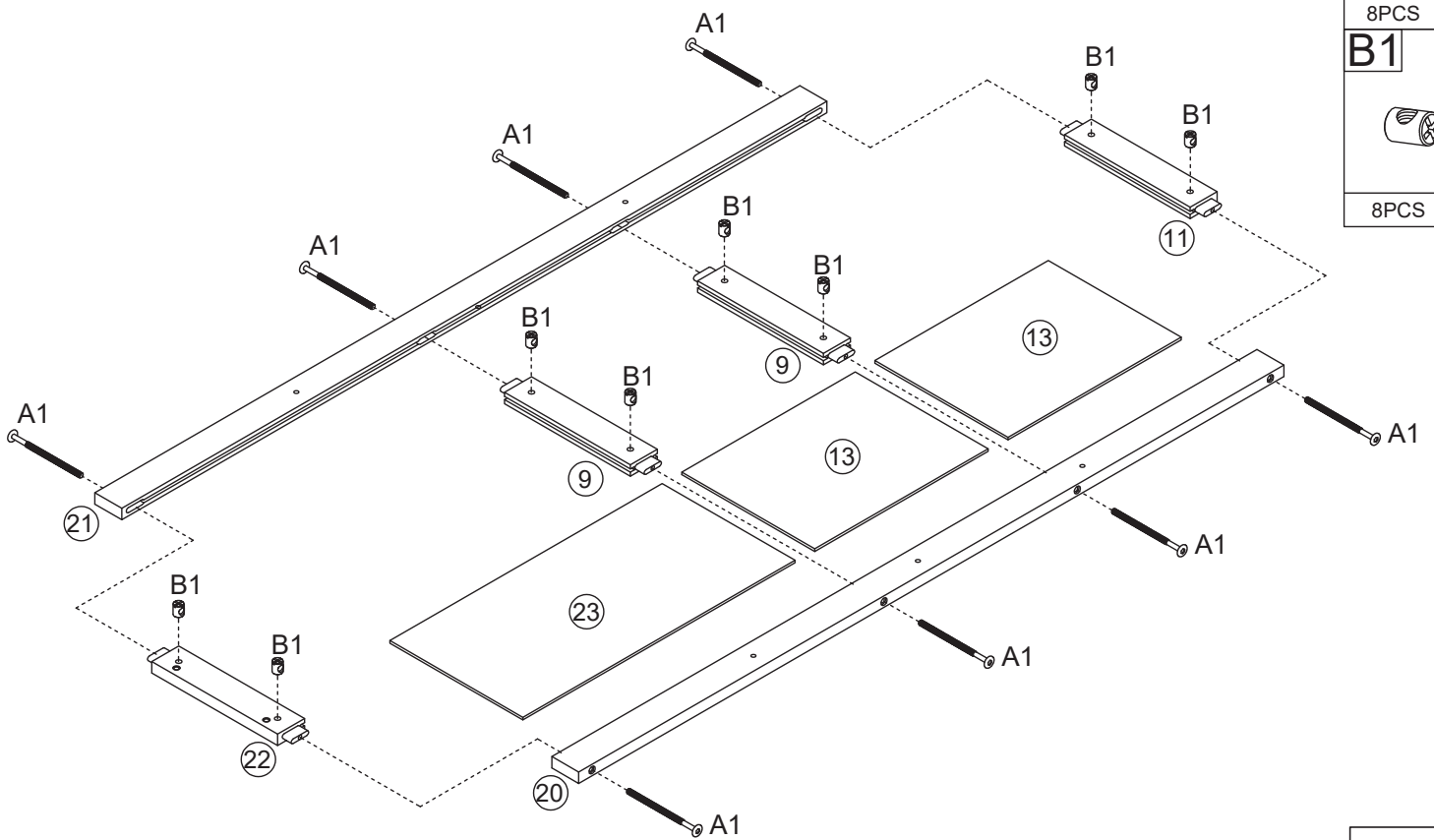

**Step 4**  
**Étape 4**



<b>A1</b>	
8PCS	
<b>B1</b>	
8PCS	

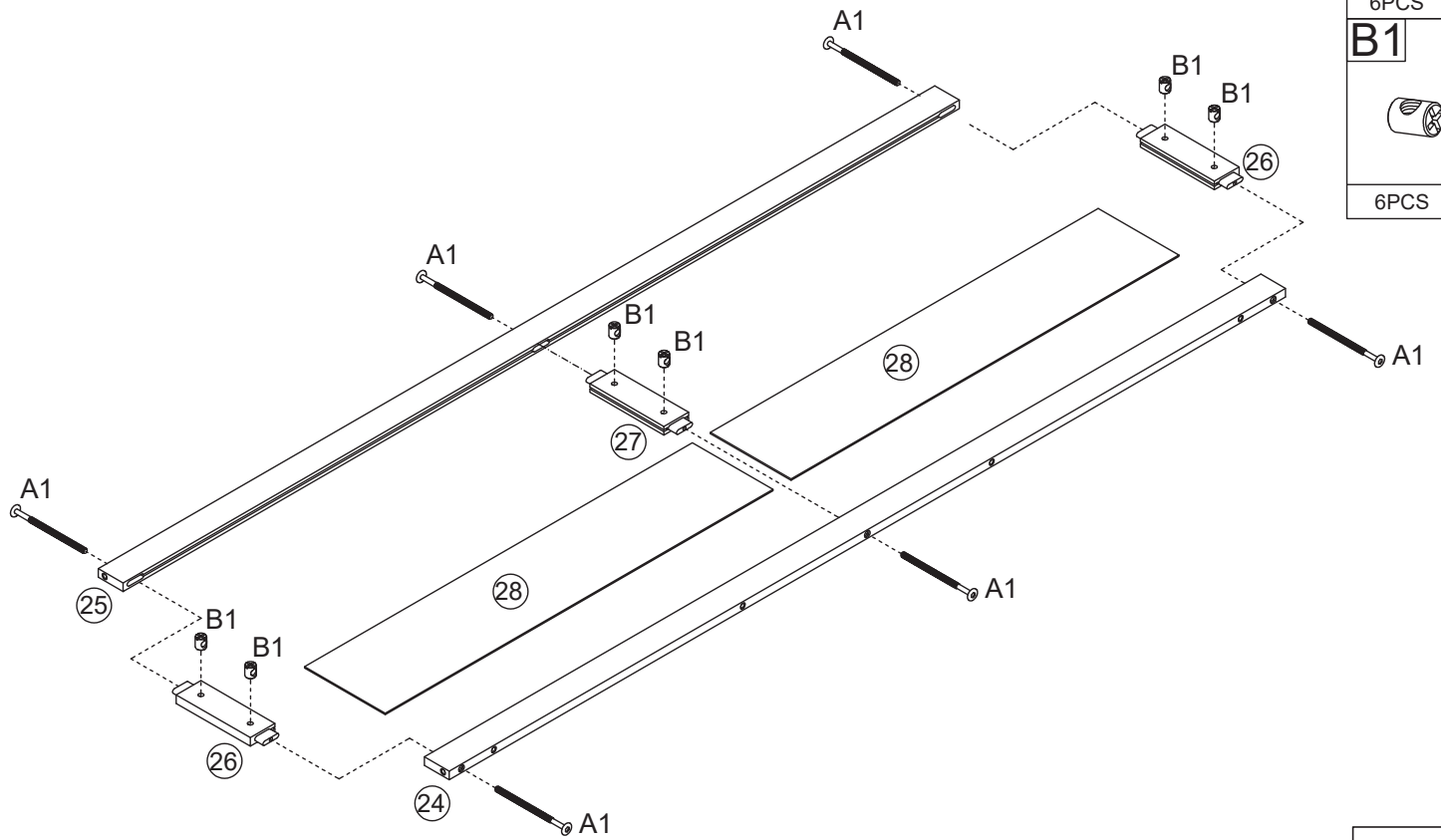

**Step 5**  
**Étape 5**

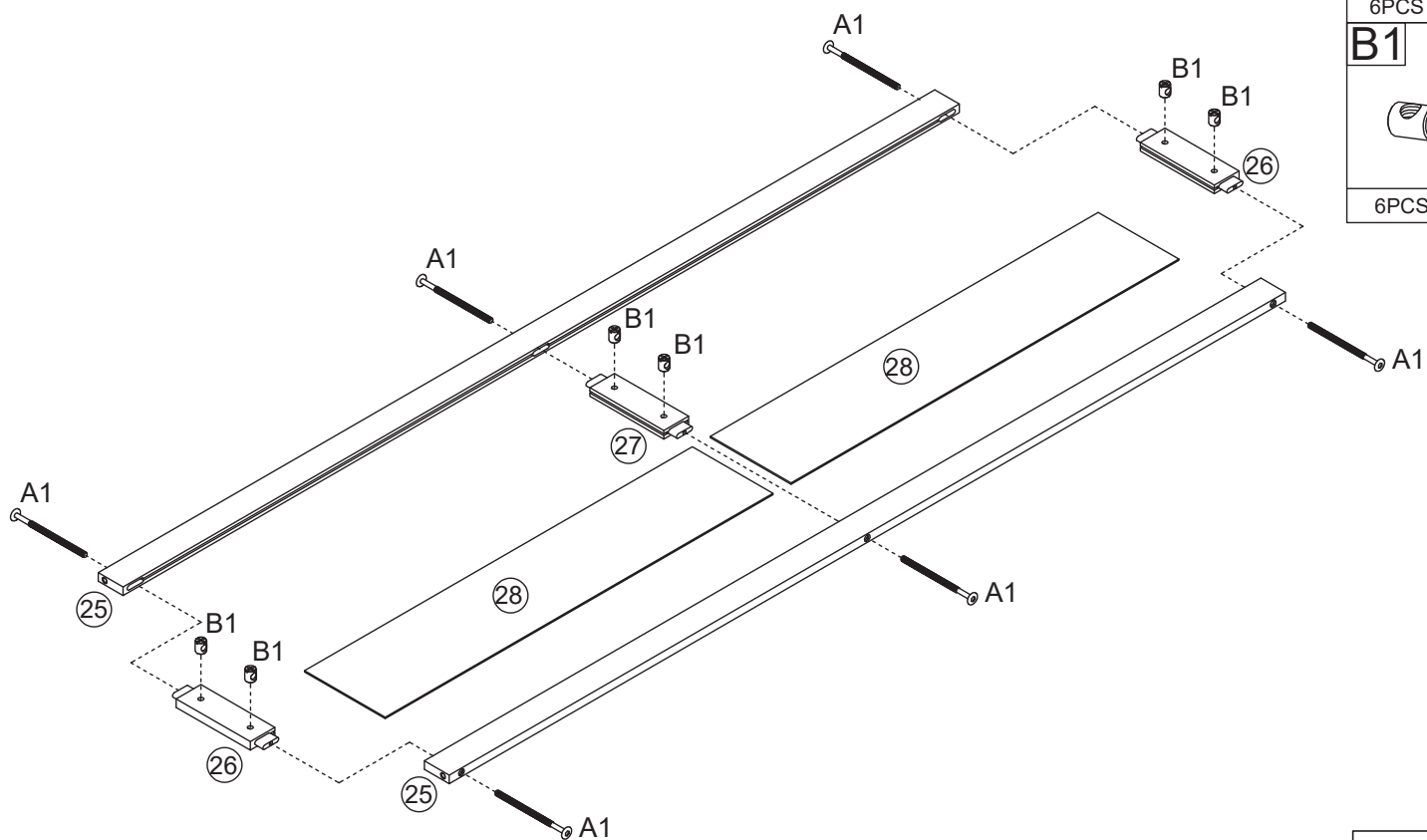

<b>A1</b>	
6PCS	
<b>B1</b>	
6PCS	

**Step 6**  
**Étape 6**



<b>A1</b>	
6PCS	
<b>B1</b>	
6PCS	

Step 7  
Étape 7

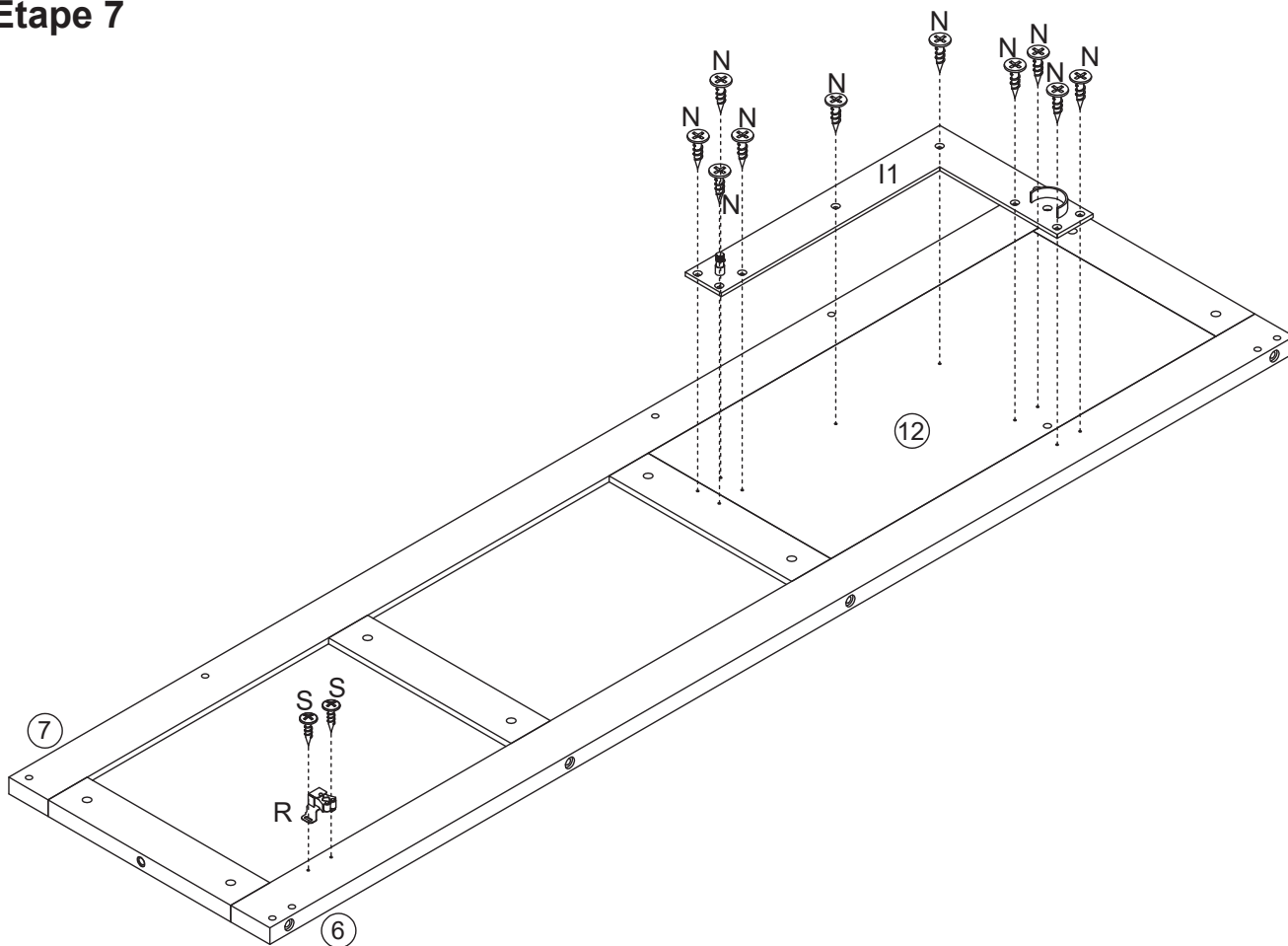

I1	
1PC	
N	
10PCS	
R	
1PC	
S	
2PCS	
16/47	

Step 8  
Étape 8

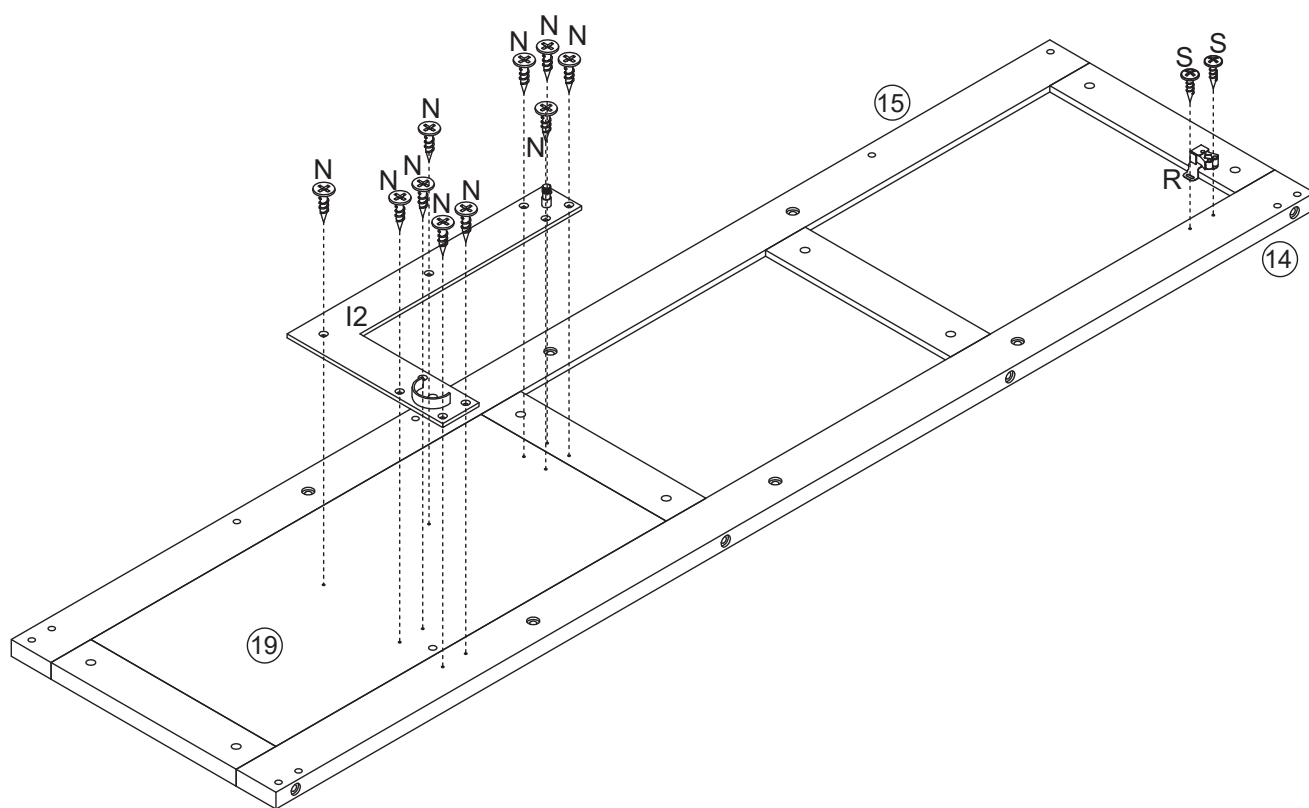

I2	
1PC	
N	
10PCS	
R	
1PC	
S	
2PCS	
17/47	

Step 9  
Étape 9

C2



16PCS

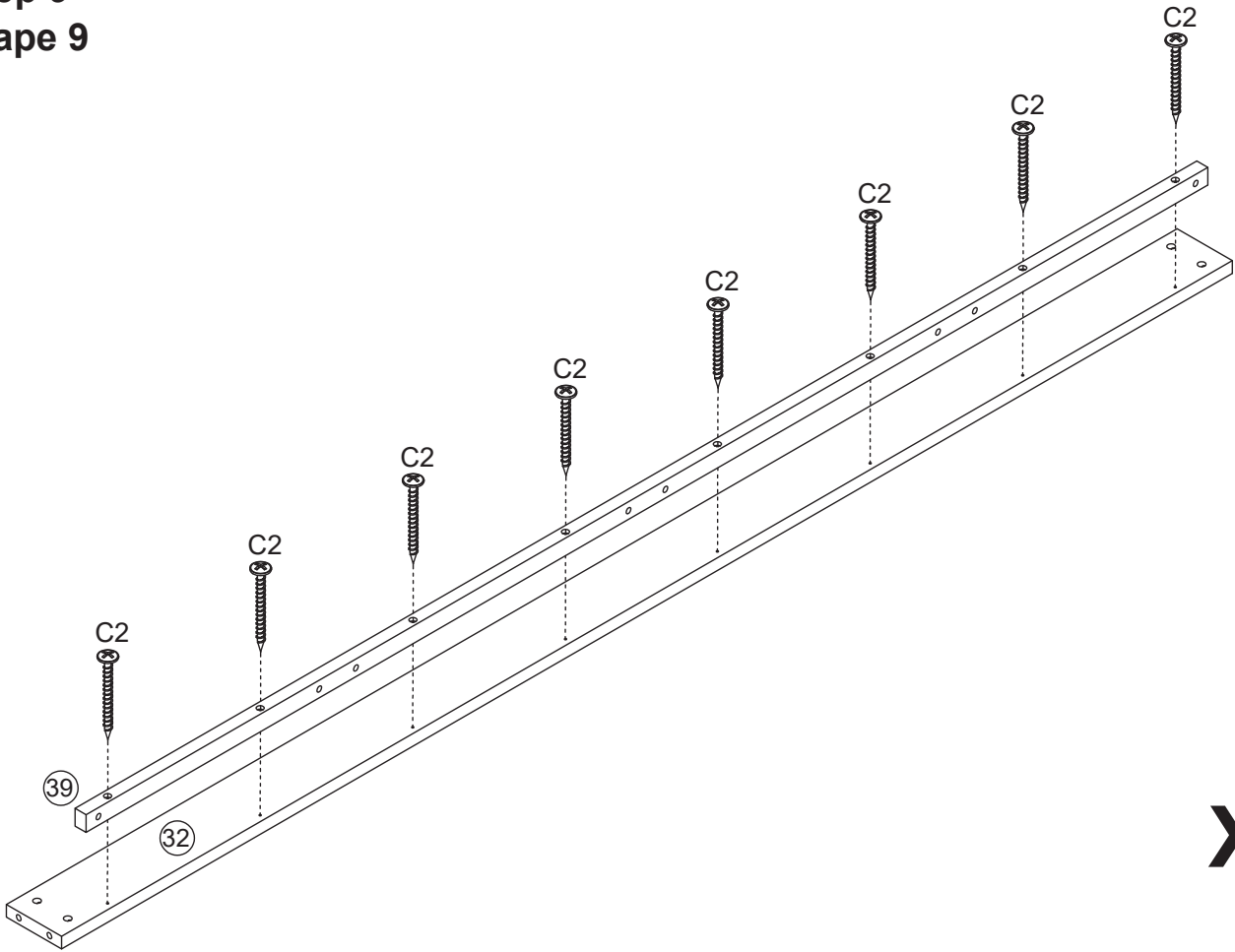

X2

**Step 10**  
**Étape 10**

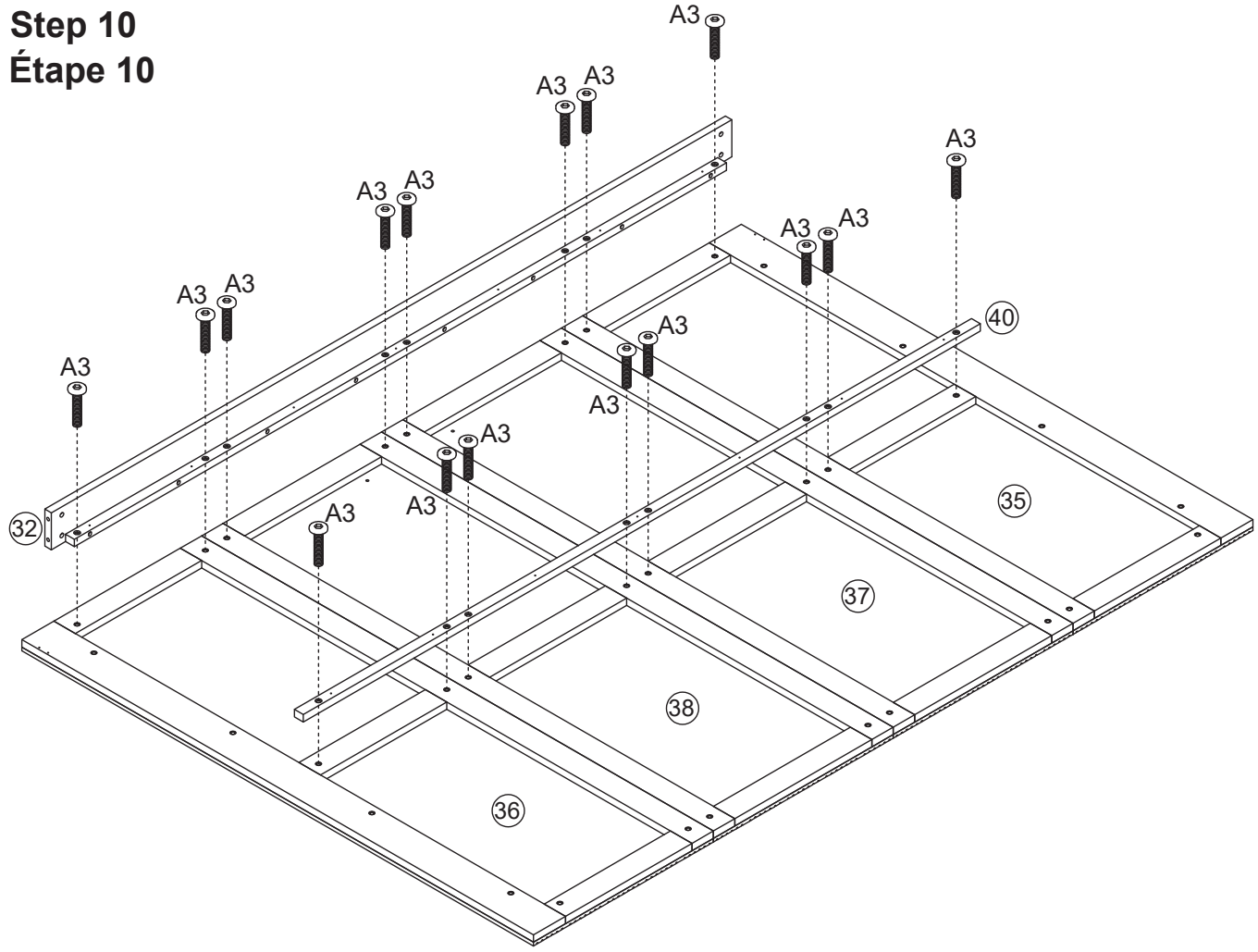

**A3**



16PCS

Step 11  
Étape 11

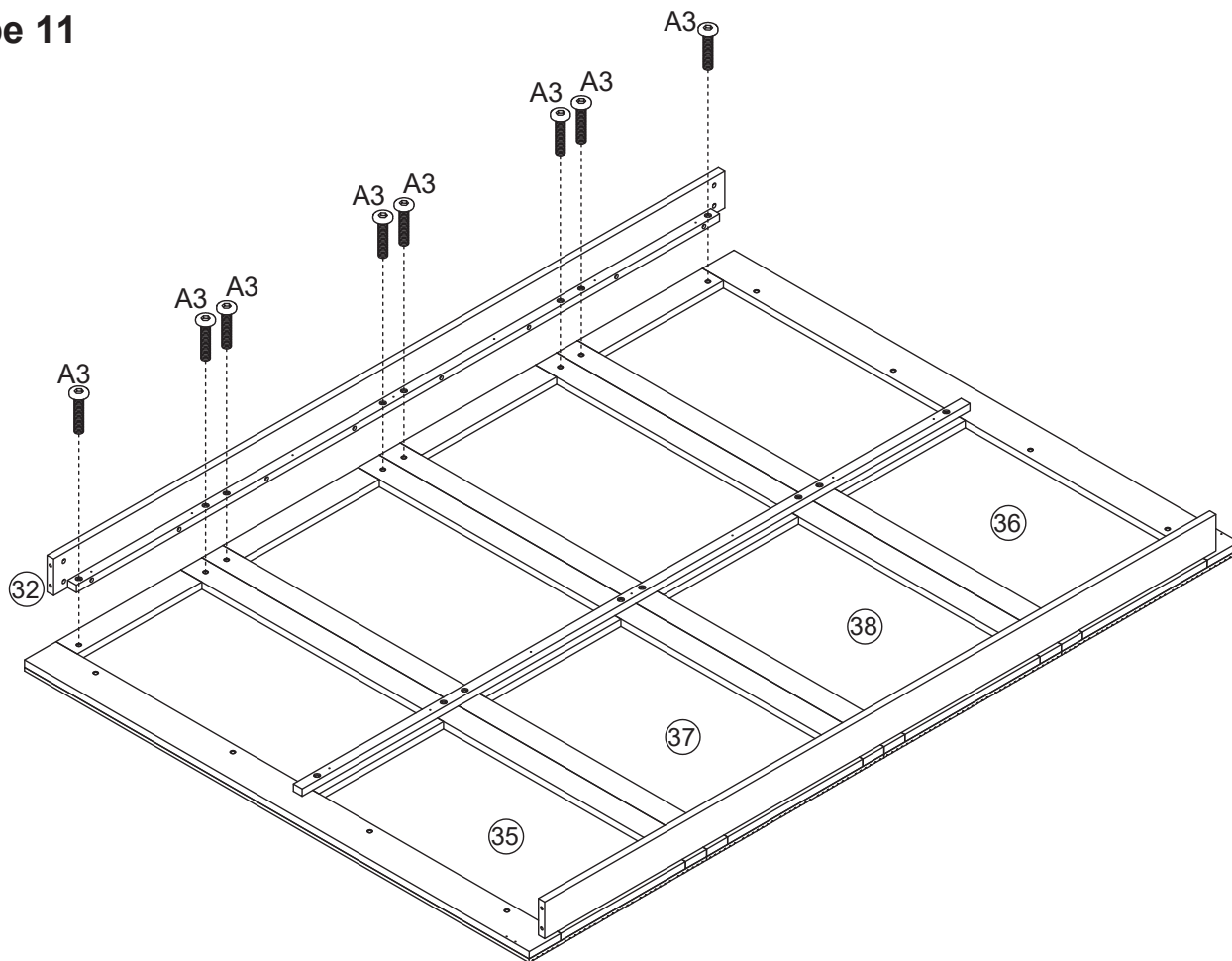



A3



8PCS

**Step 12**  
**Étape 12**

<b>A2</b>	<b>B1</b>
	
8PCS	8PCS

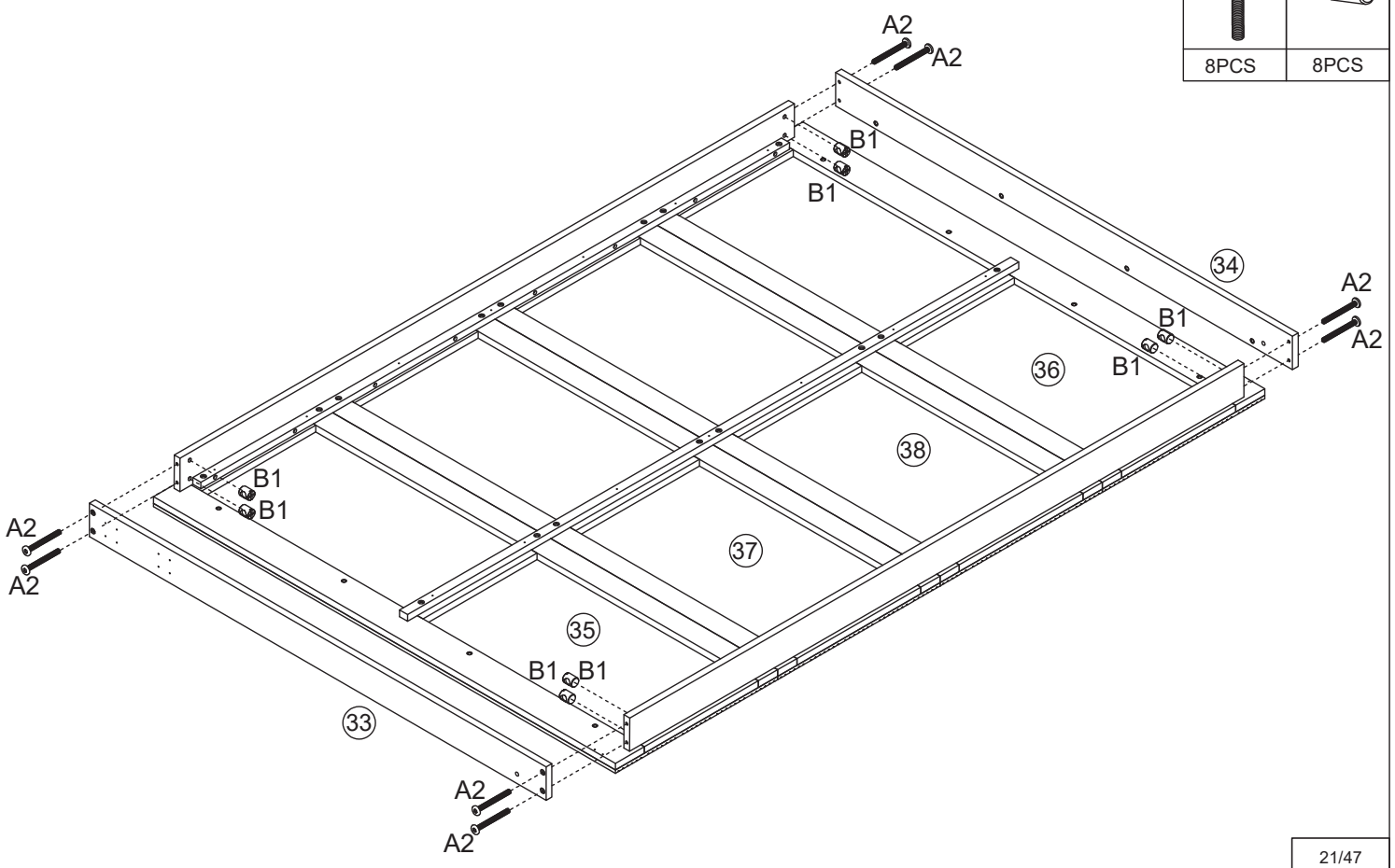

**Step 13**  
**Étape 13**

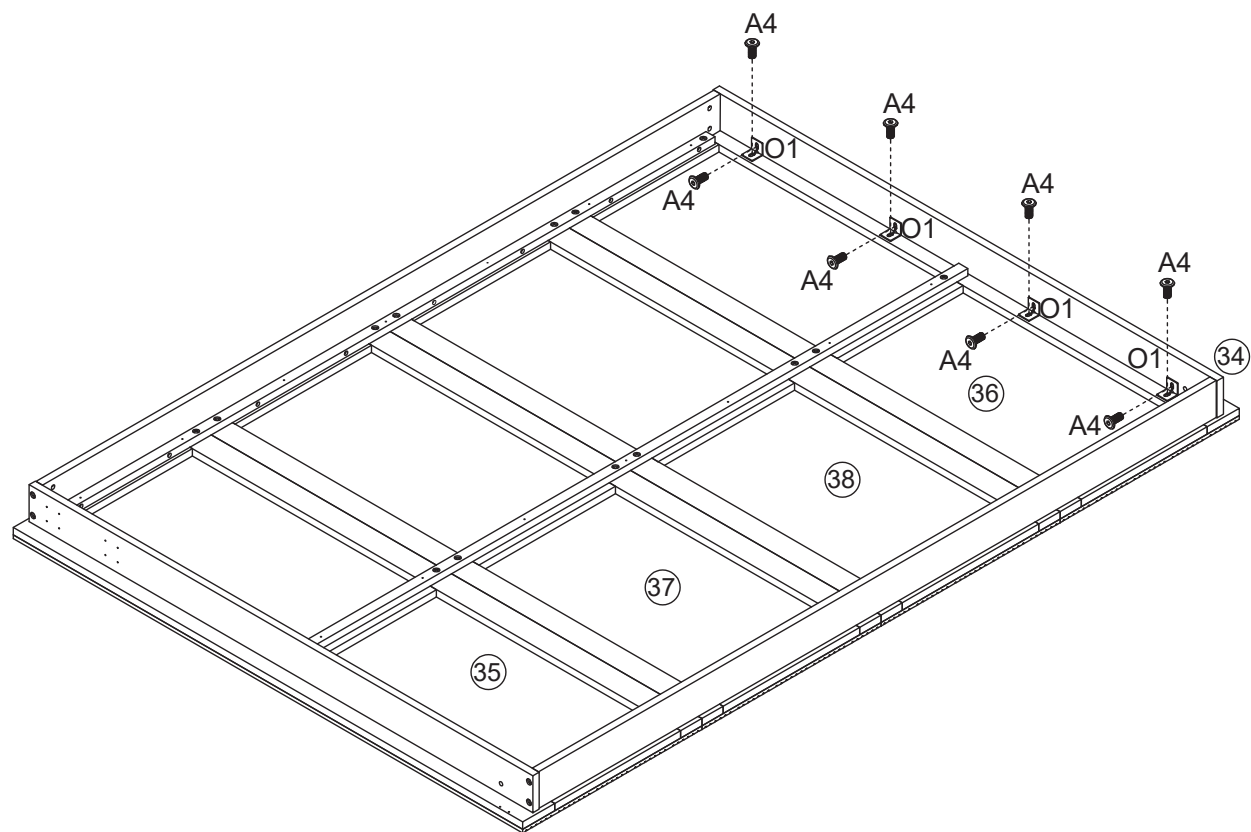

**A4**



8PCS

**O1**



4PCS

**Step 14**  
**Étape 14**

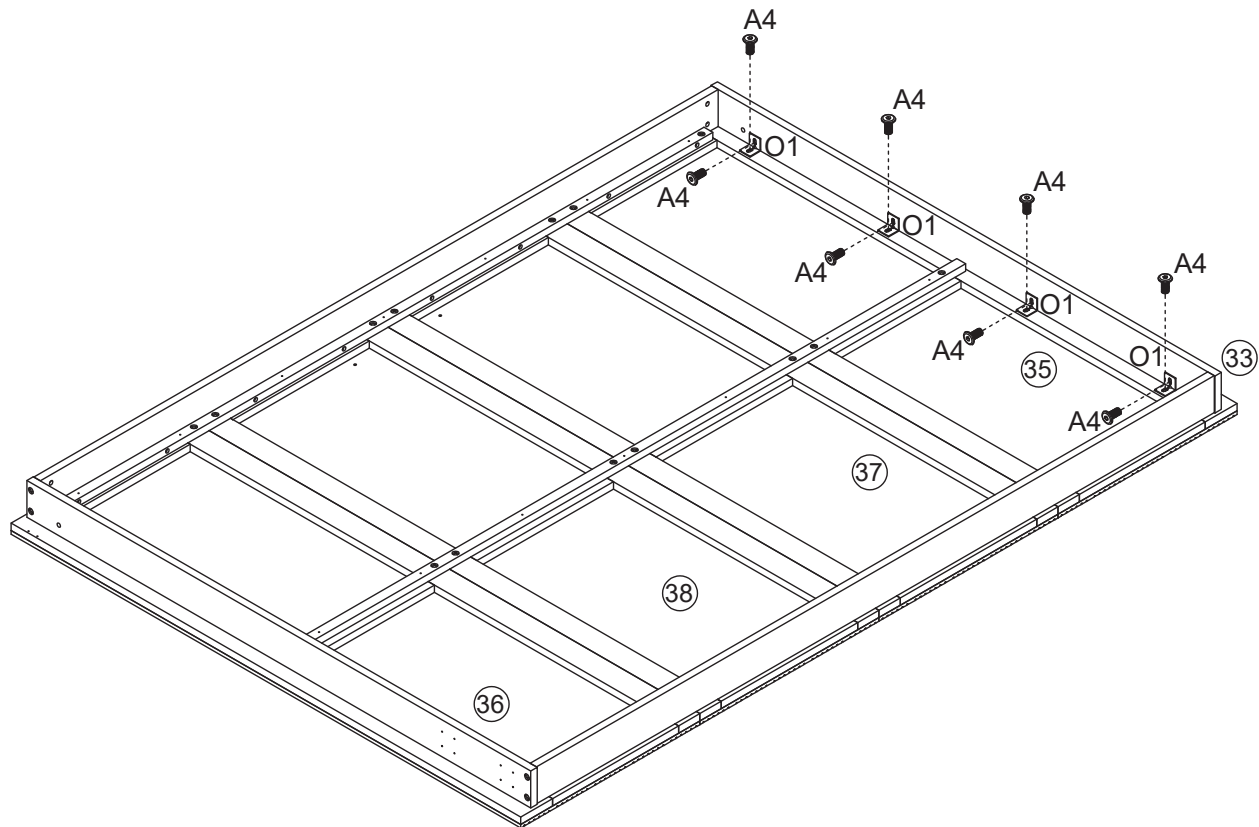

**A4**



8PCS

**O1**



4PCS

**Step 15**  
**Étape 15**

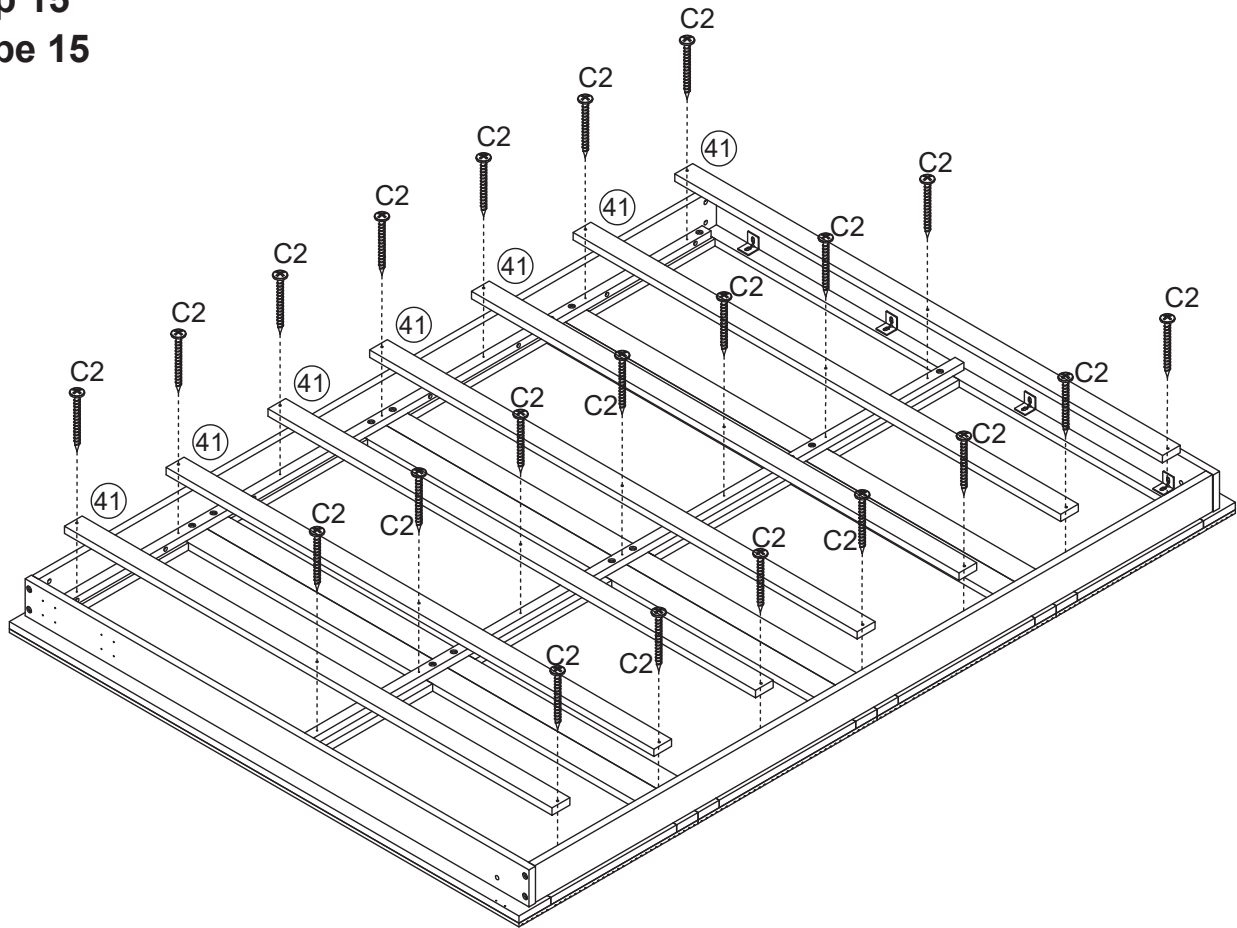

**C2**



21PCS

Step 16  
Étape 16

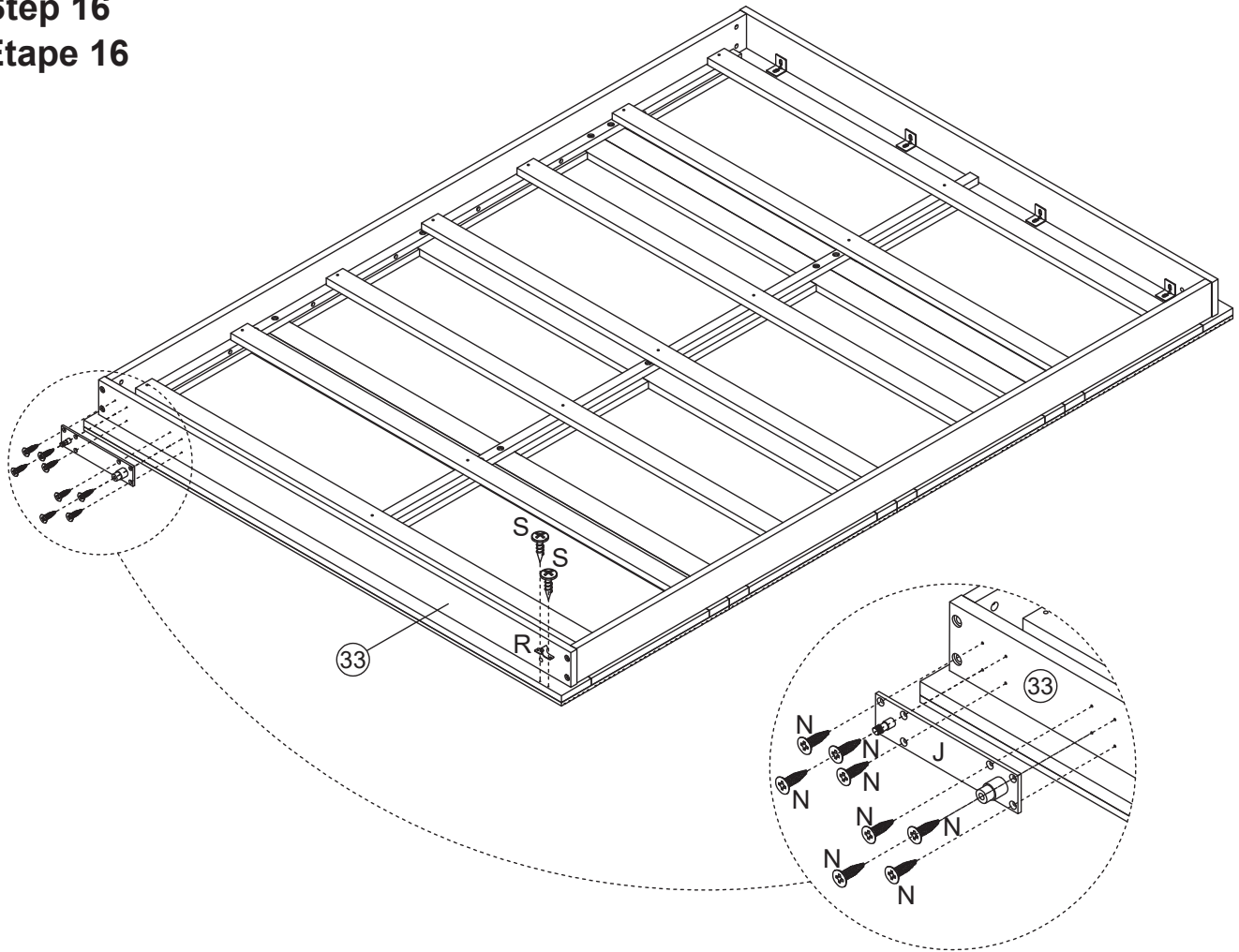

J



1PC

N



8PCS

R



1PC

S



2PCS

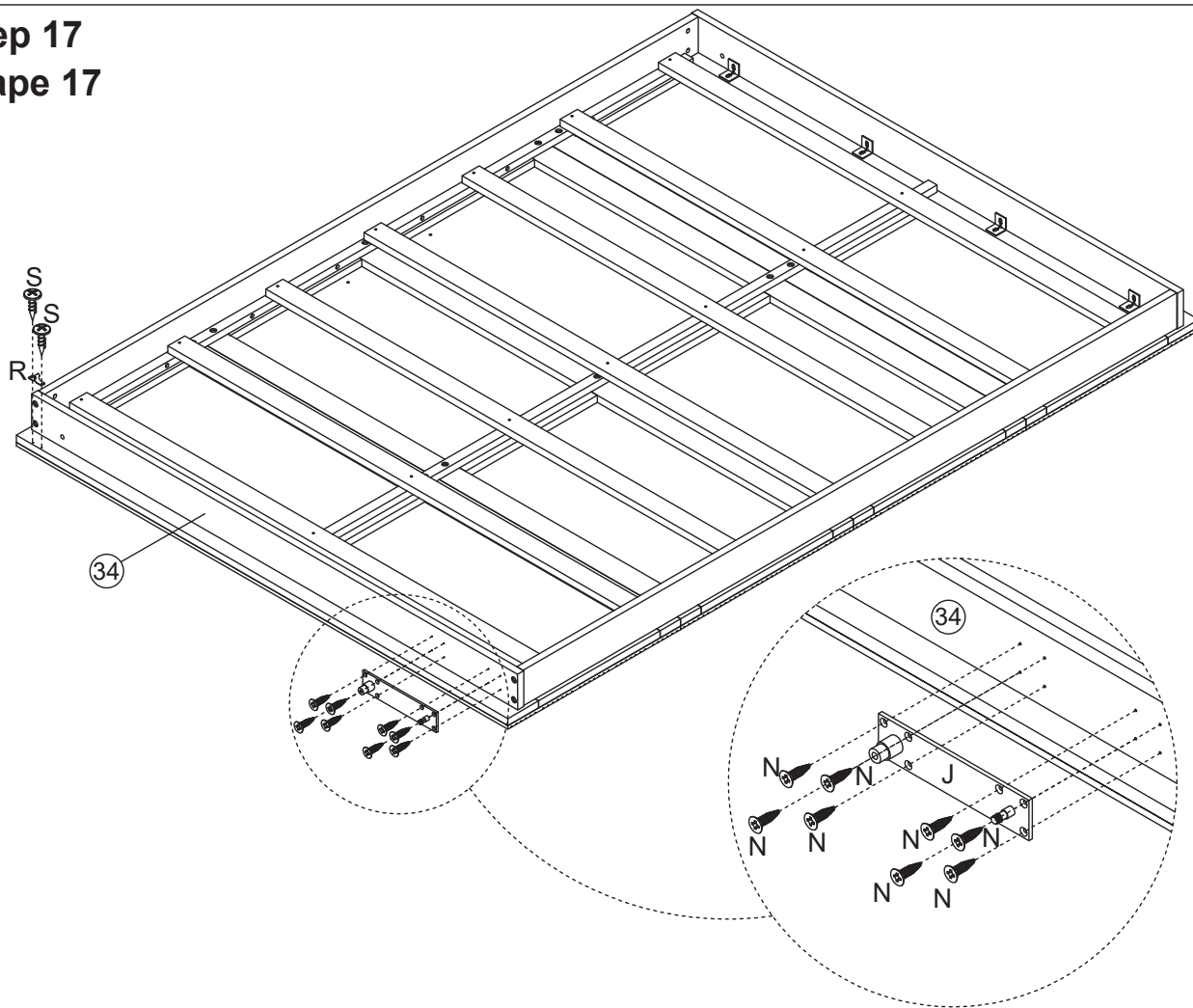

**Step 17**  
**Étape 17**

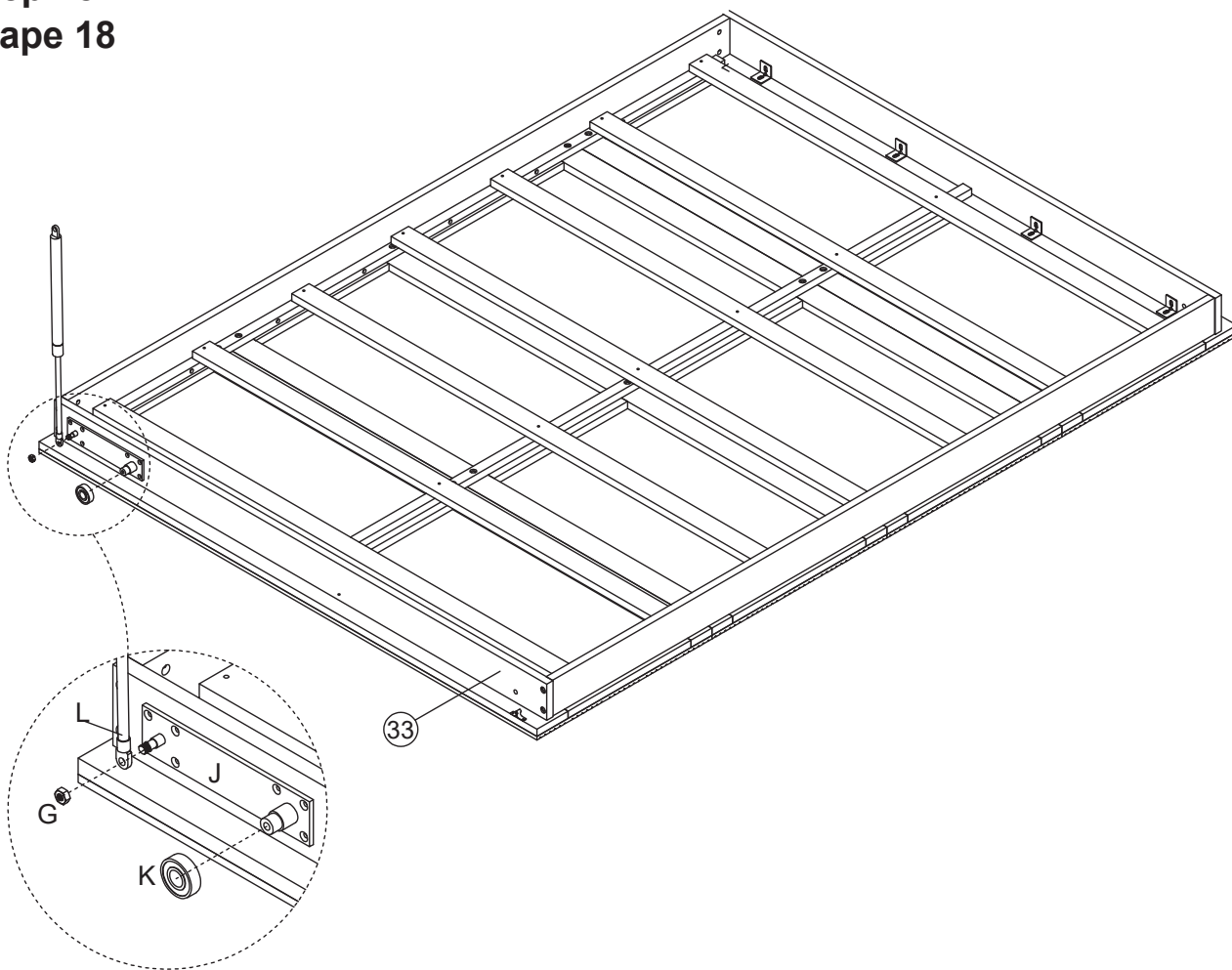

<b>J</b>		1PC
<b>N</b>		8PCS
<b>R</b>		1PC
<b>S</b>		2PCS
26/47		

Step 18  
Étape 18





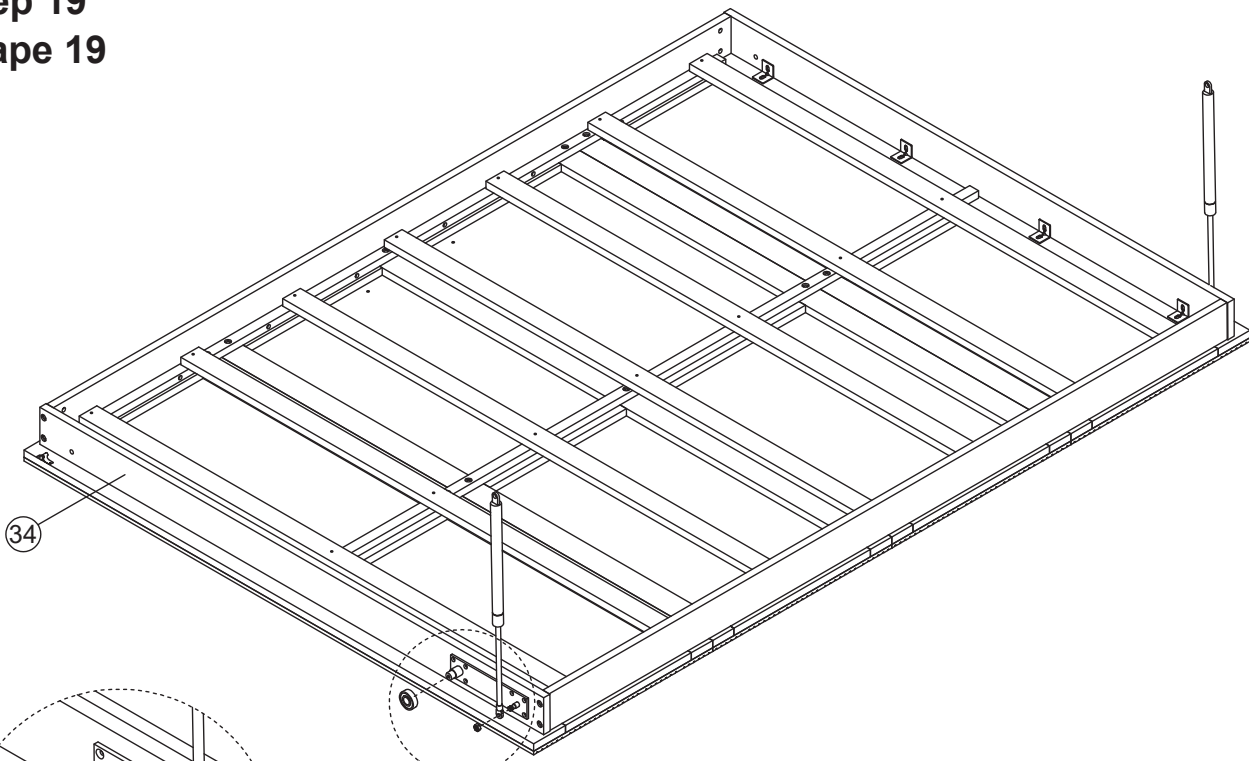

- G**  
  
1PC
- K**  
  
1PC
- L**  
  
1PC

**Step 19**  
**Étape 19**

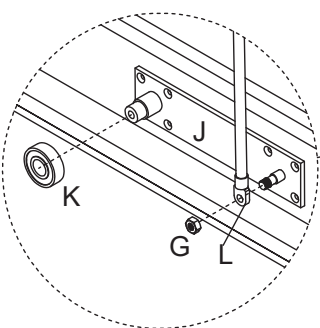

34



- G**  
  
1PC
- K**  
  
1PC
- L**  
  
1PC

Step 20  
Étape 20

C3



3PCS

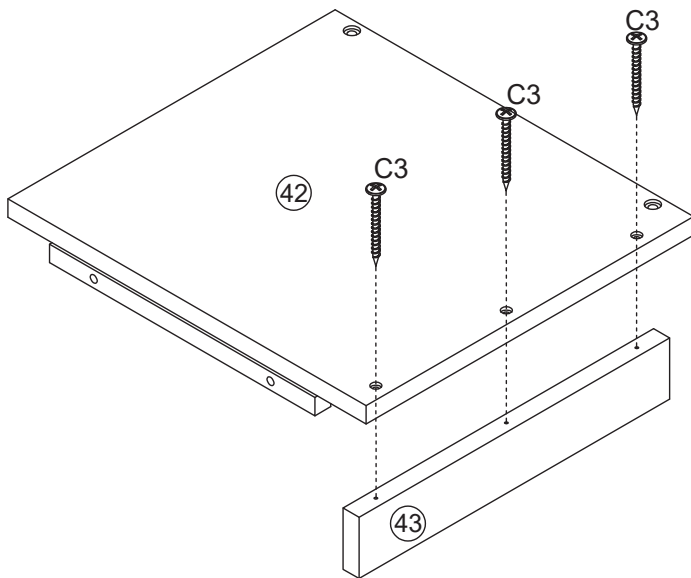

Step 21  
Étape 21

C1



9PCS

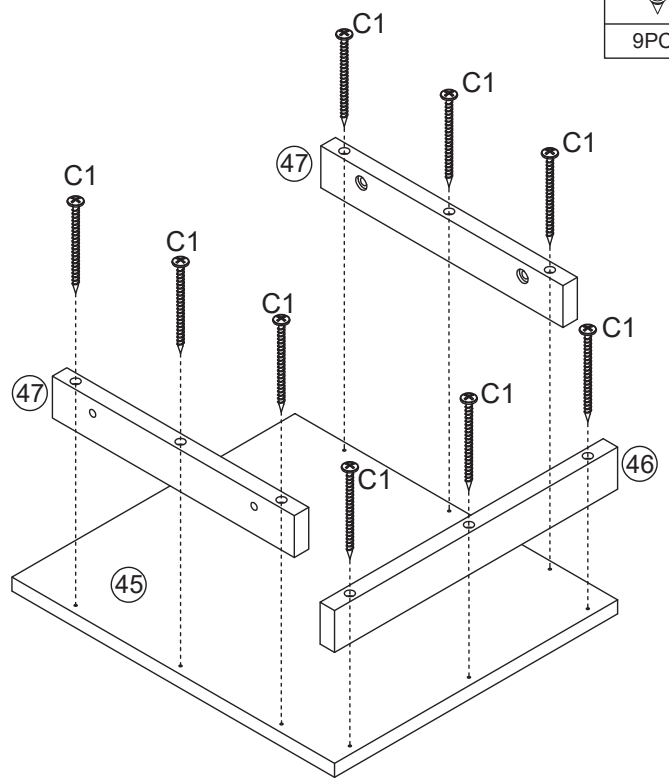

Step 22  
Étape 22

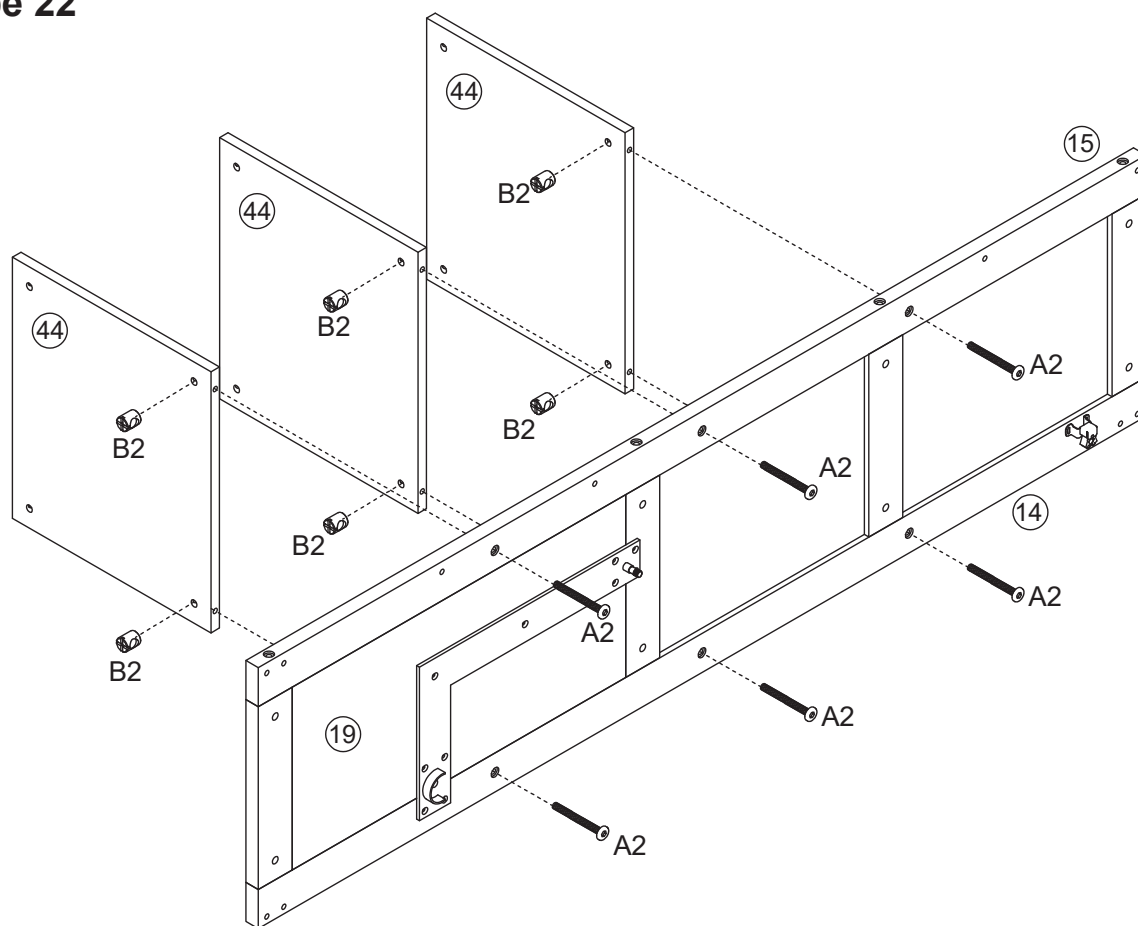

A2



6PCS

B2



6PCS

**Step 23**  
**Étape 23**

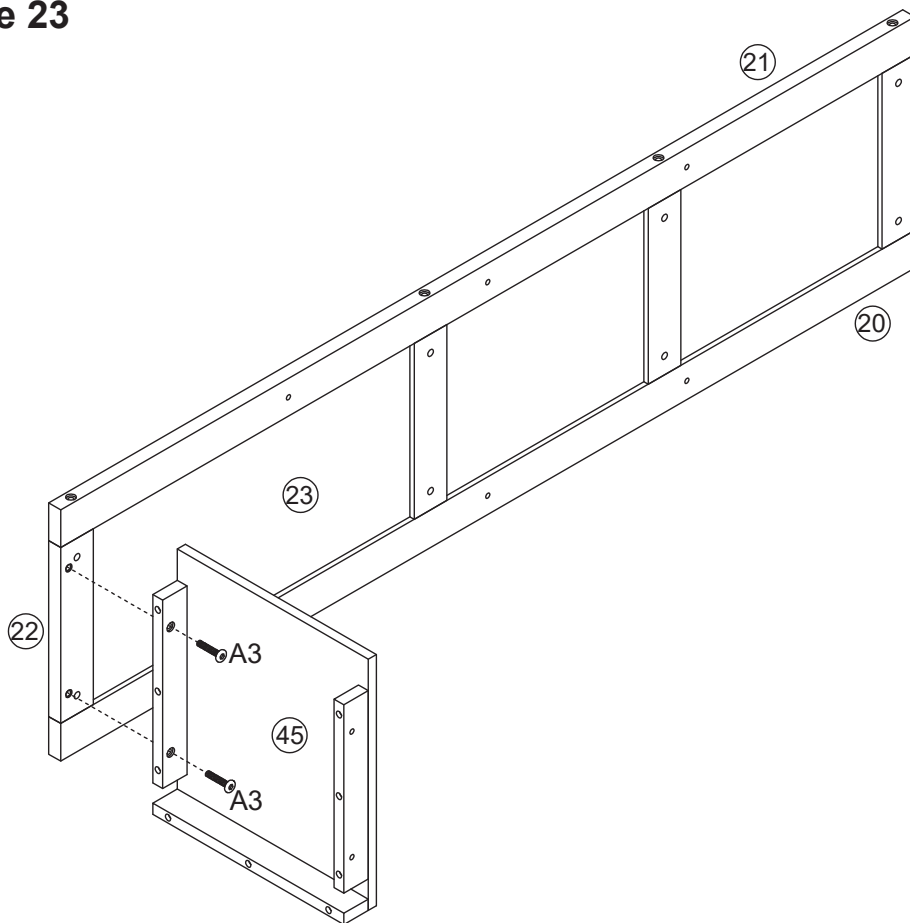



**A3**





2PCS

**Step 24**  
**Étape 24**

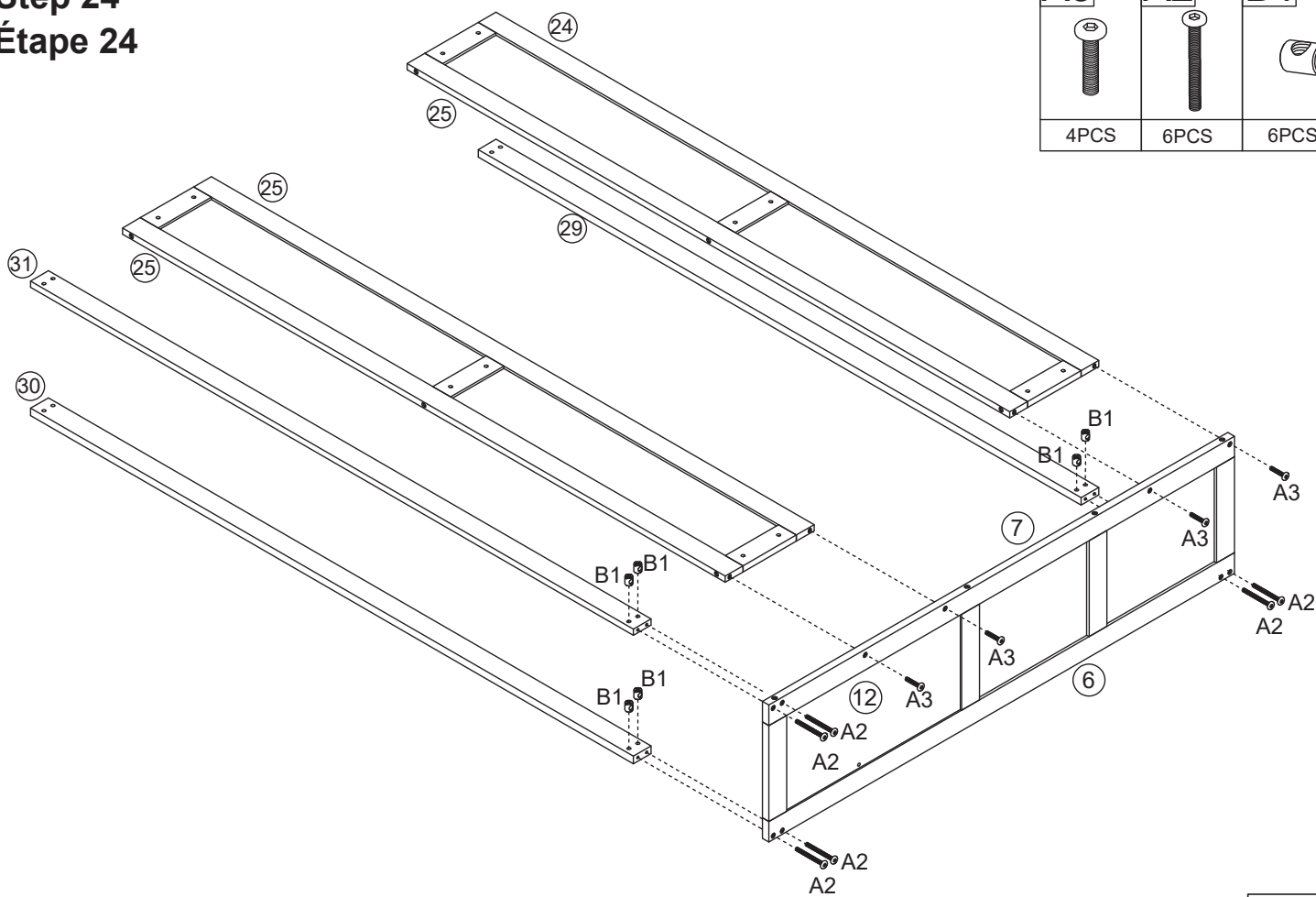
A3	A2	B1
		
4PCS	6PCS	6PCS



# Step 25 Étape 25

A3	A2	B1
		
4PCS	6PCS	6PCS

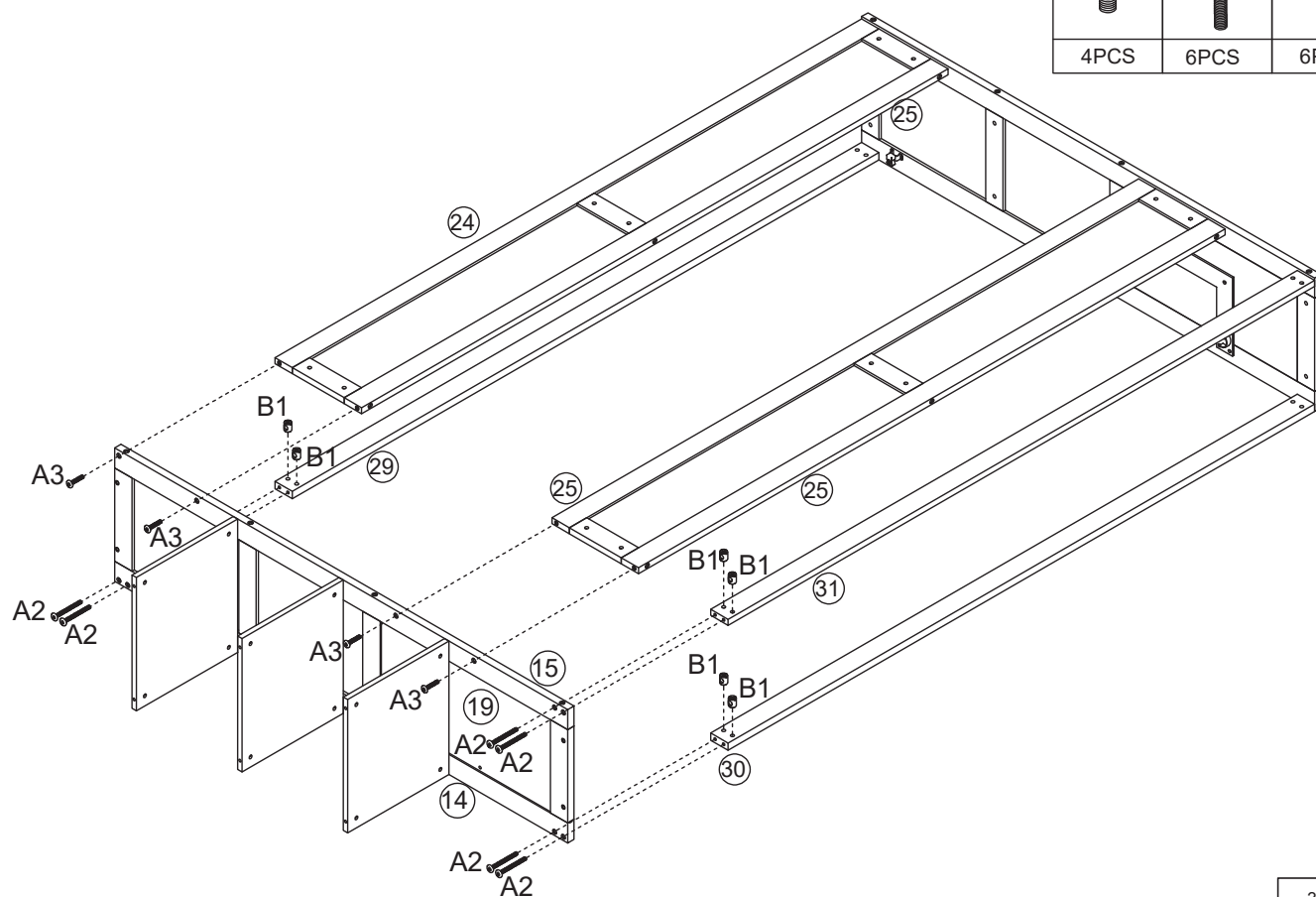

Step 26  
Étape 26



A3

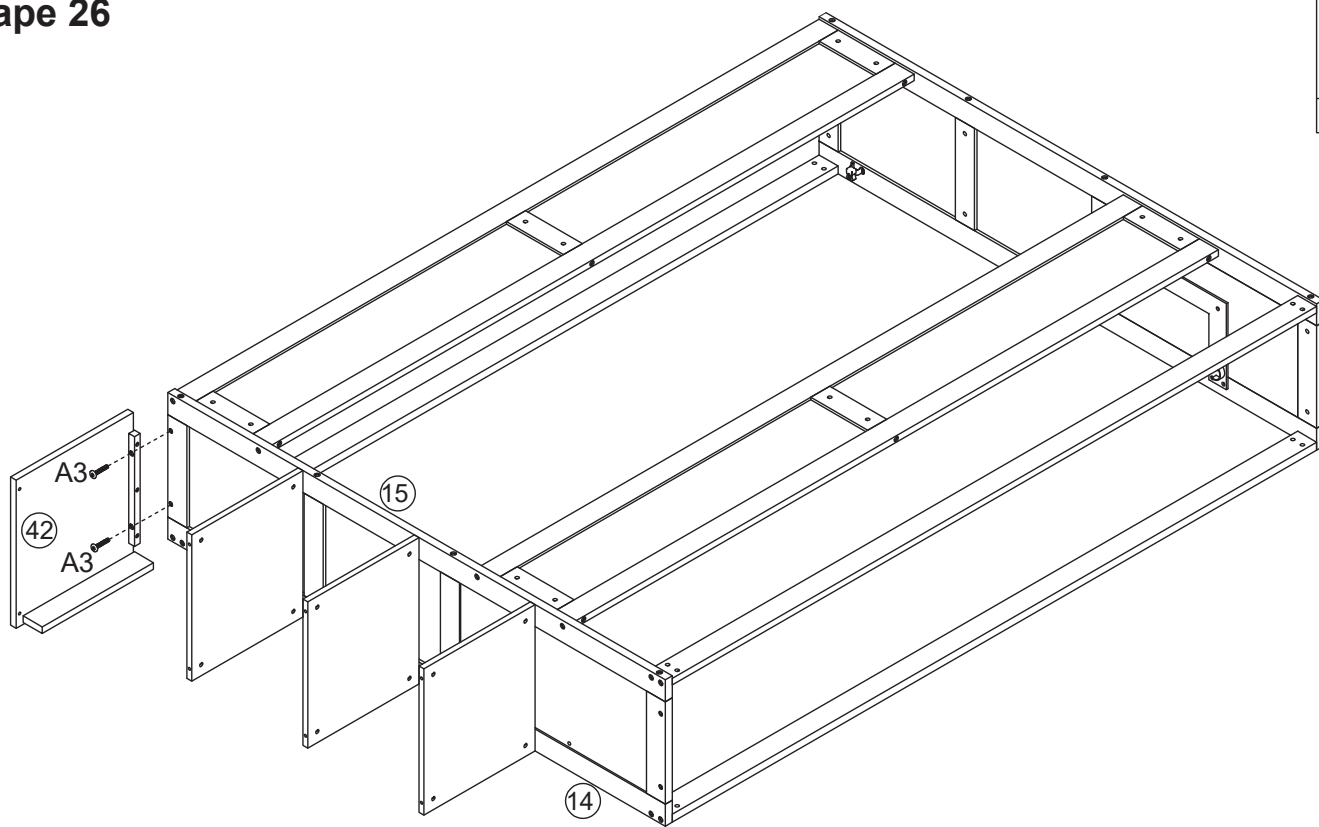

2PCS



Step 27  
Étape 27

A2	B2	A3
		
6PCS	6PCS	2PCS

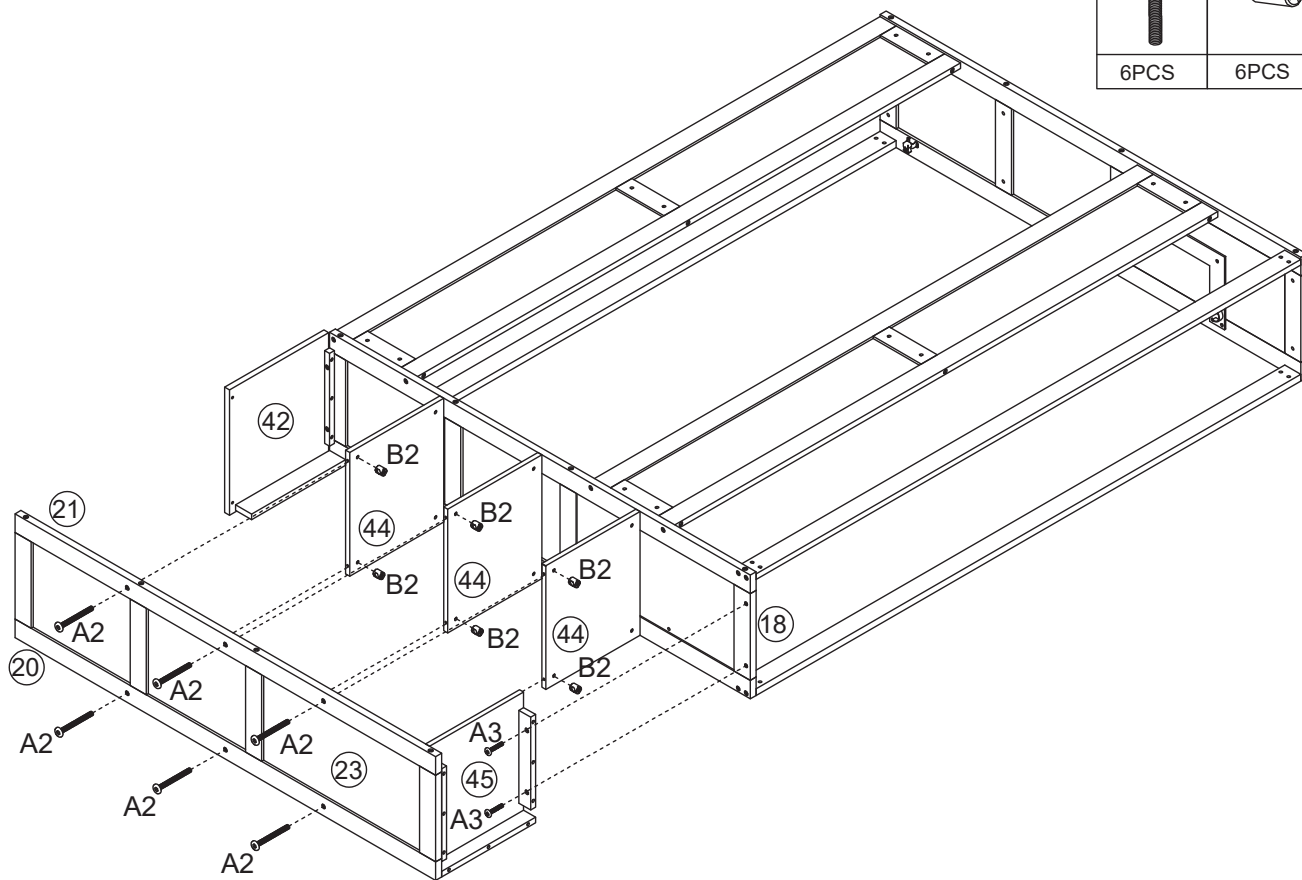

**Step 28**  
**Étape 28**



**A3**

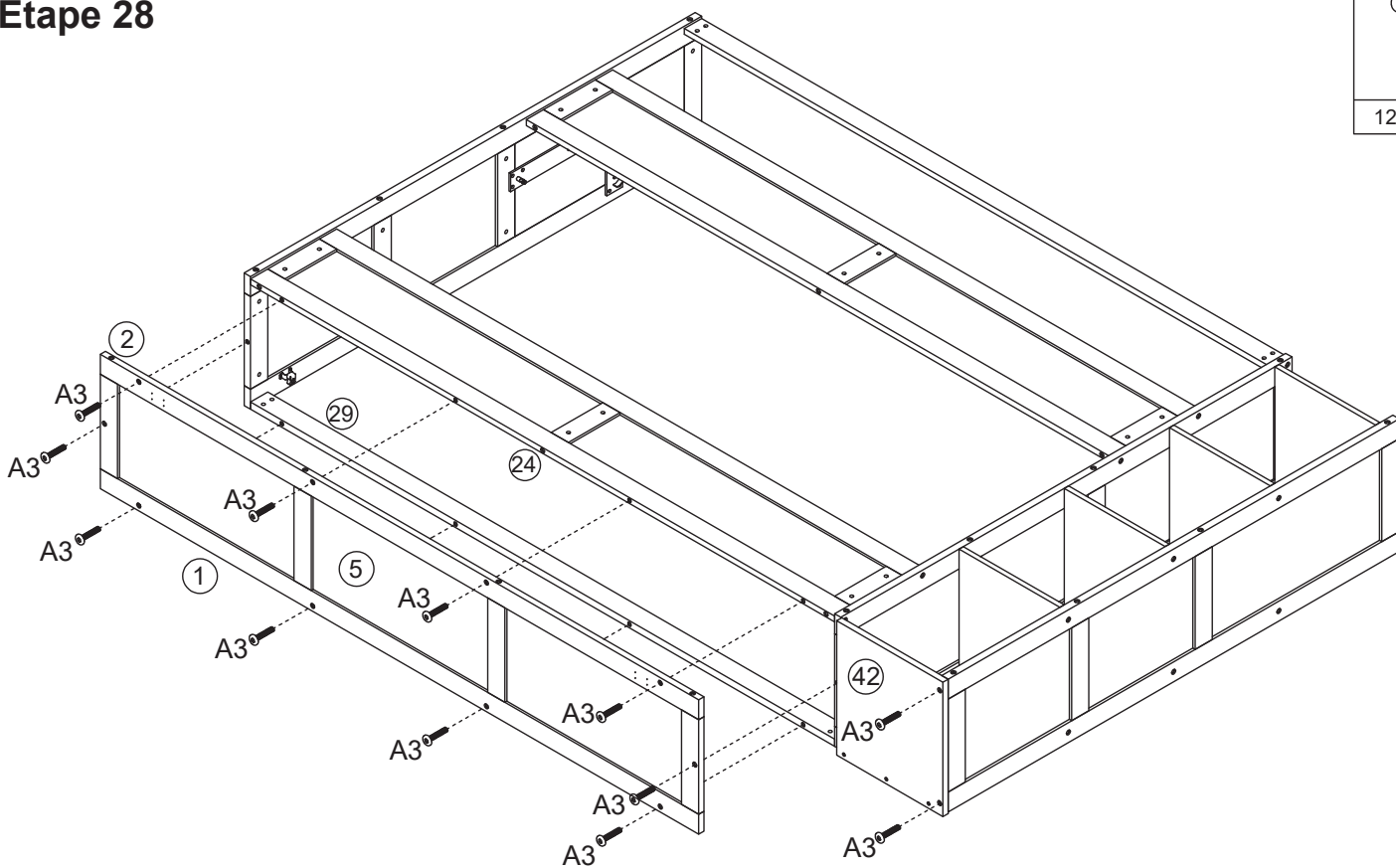

12PCS

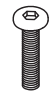

Step 29  
Étape 29

D	E	M
		
1PC	2PCS	2PCS

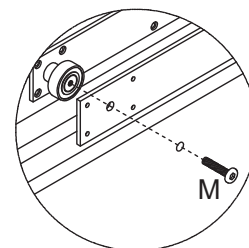
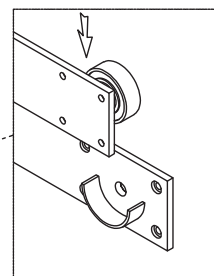
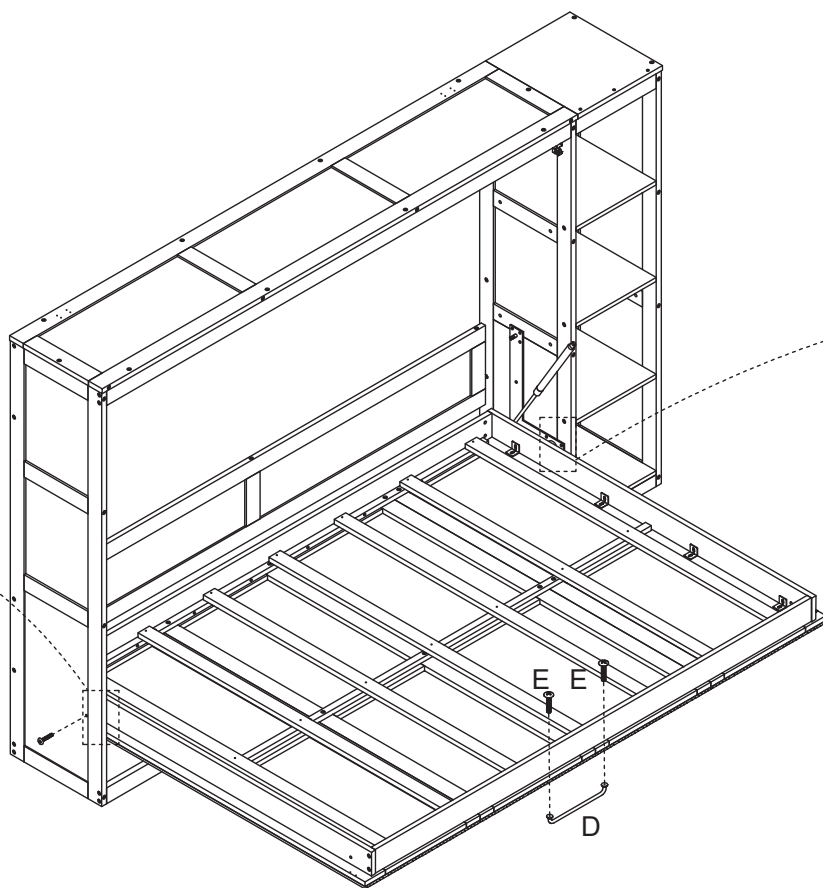
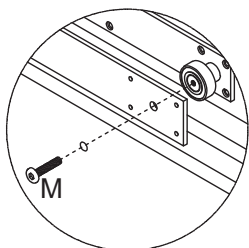
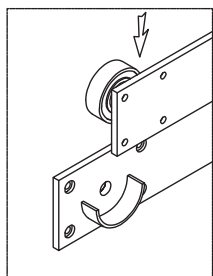

**Step 30**  
**Étape 30**

**G**



1PC

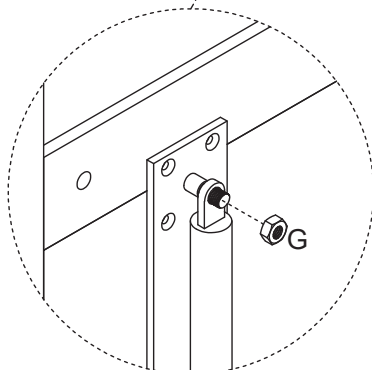
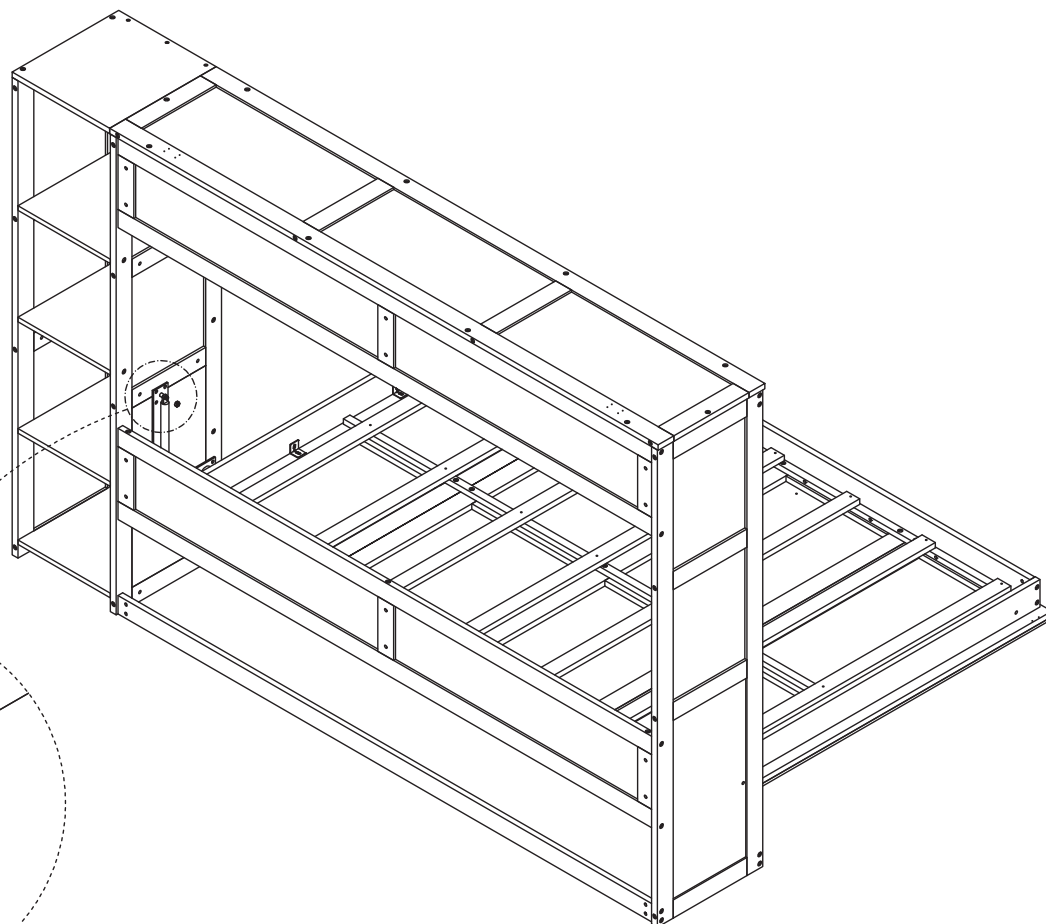

**Step 31**  
**Étape 31**

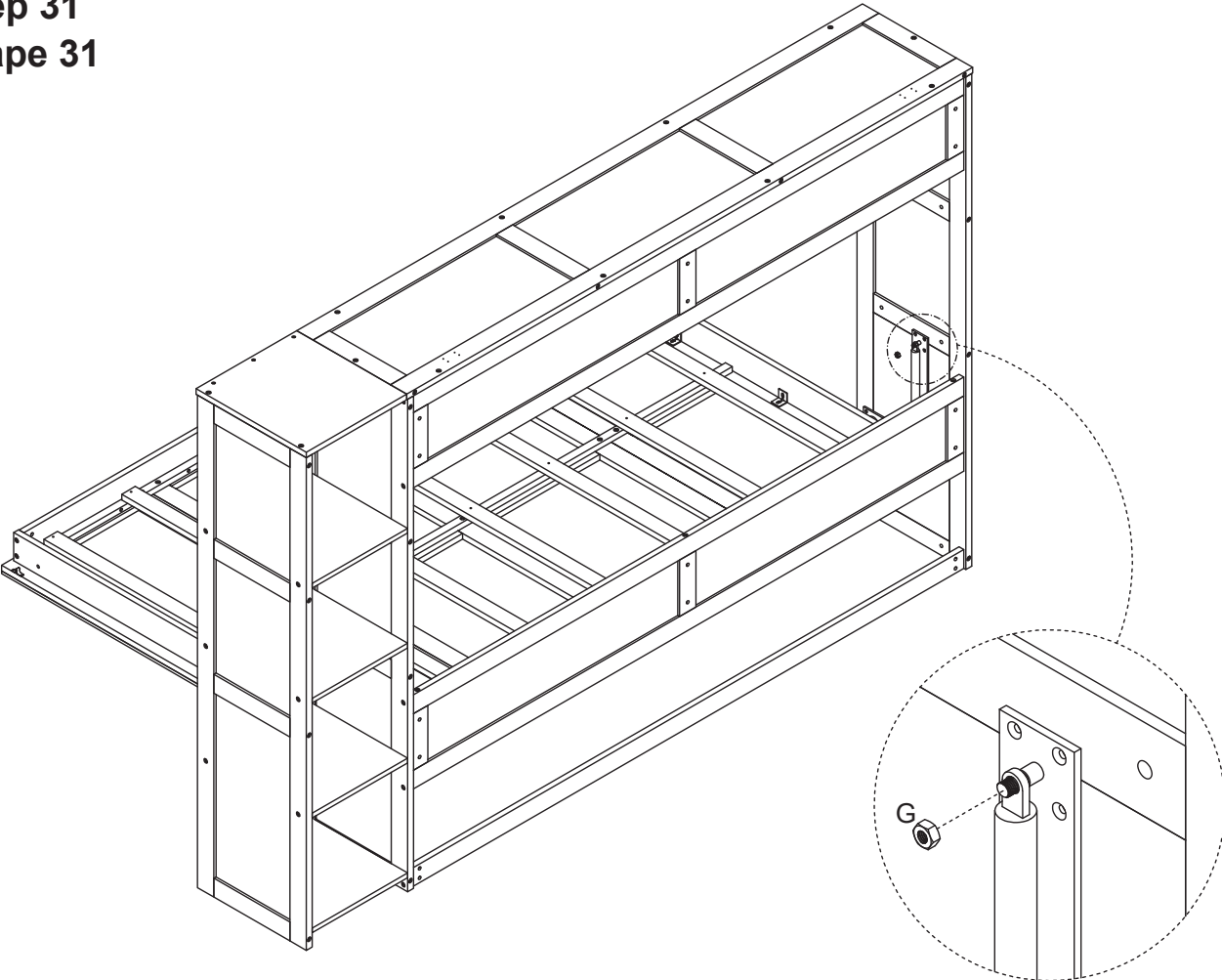





**G**

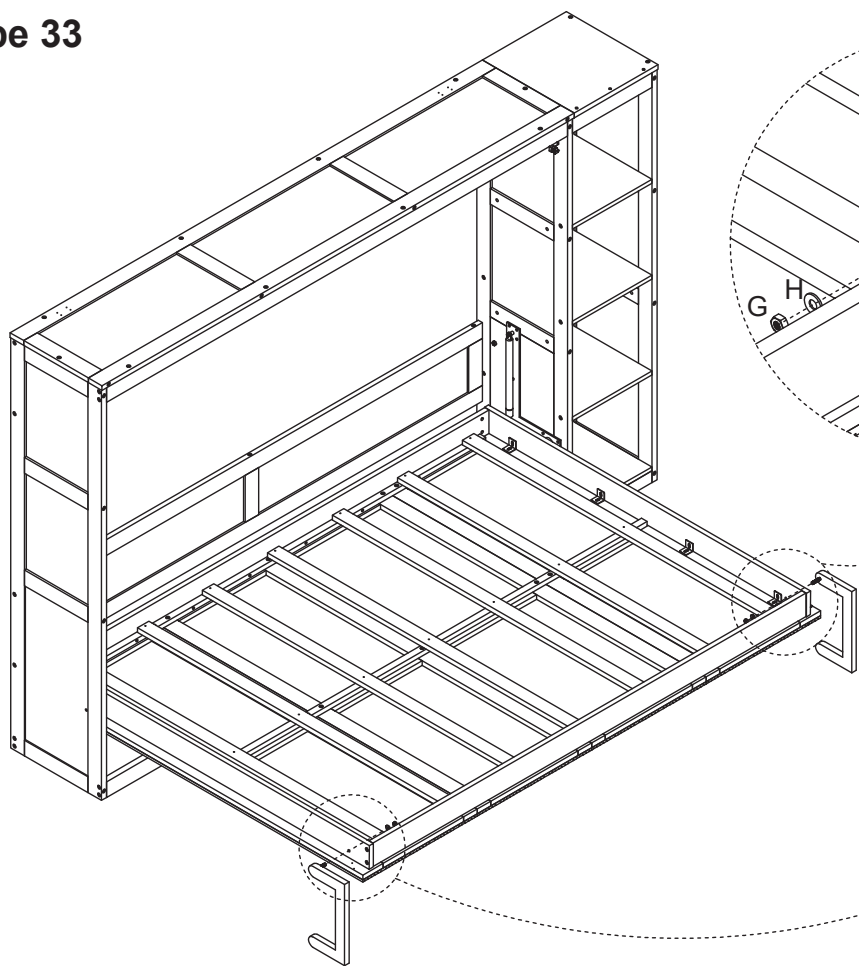

1PC

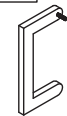
**Step 33**  
**Étape 33**



<b>F1</b>  1PC	<b>G</b>  2PCS
<b>F2</b>  1PC	<b>H</b>  2PCS

**Step 34**  
**Étape 34**

**OPEN STATE**

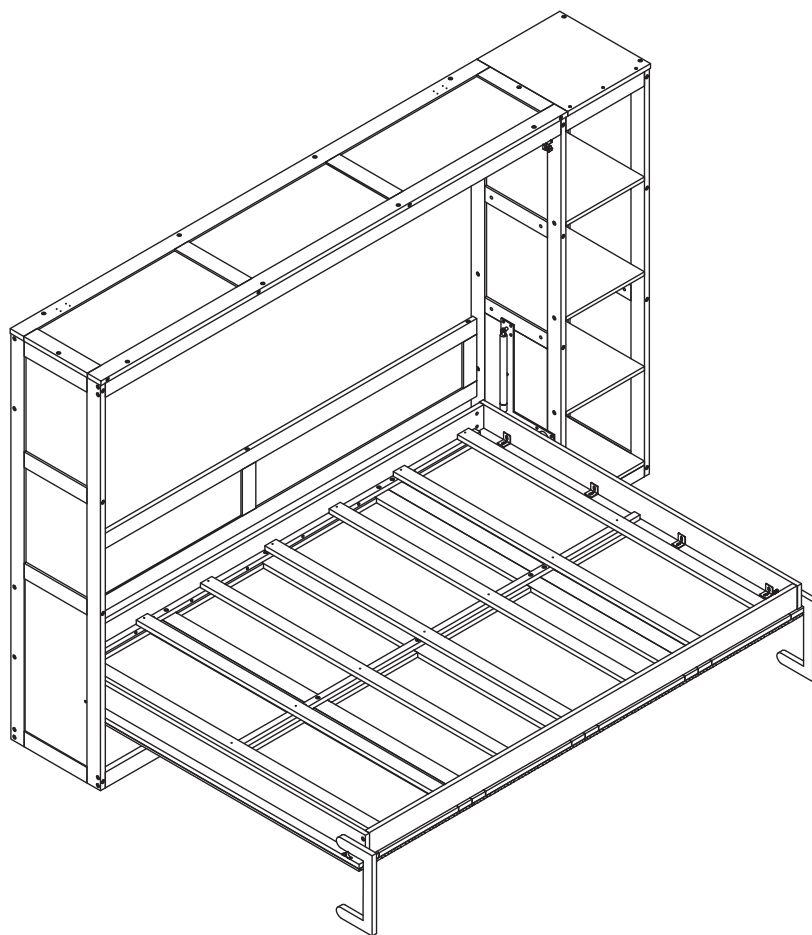

**Step 35**  
**Étape 35**

**CLOSE STATE**

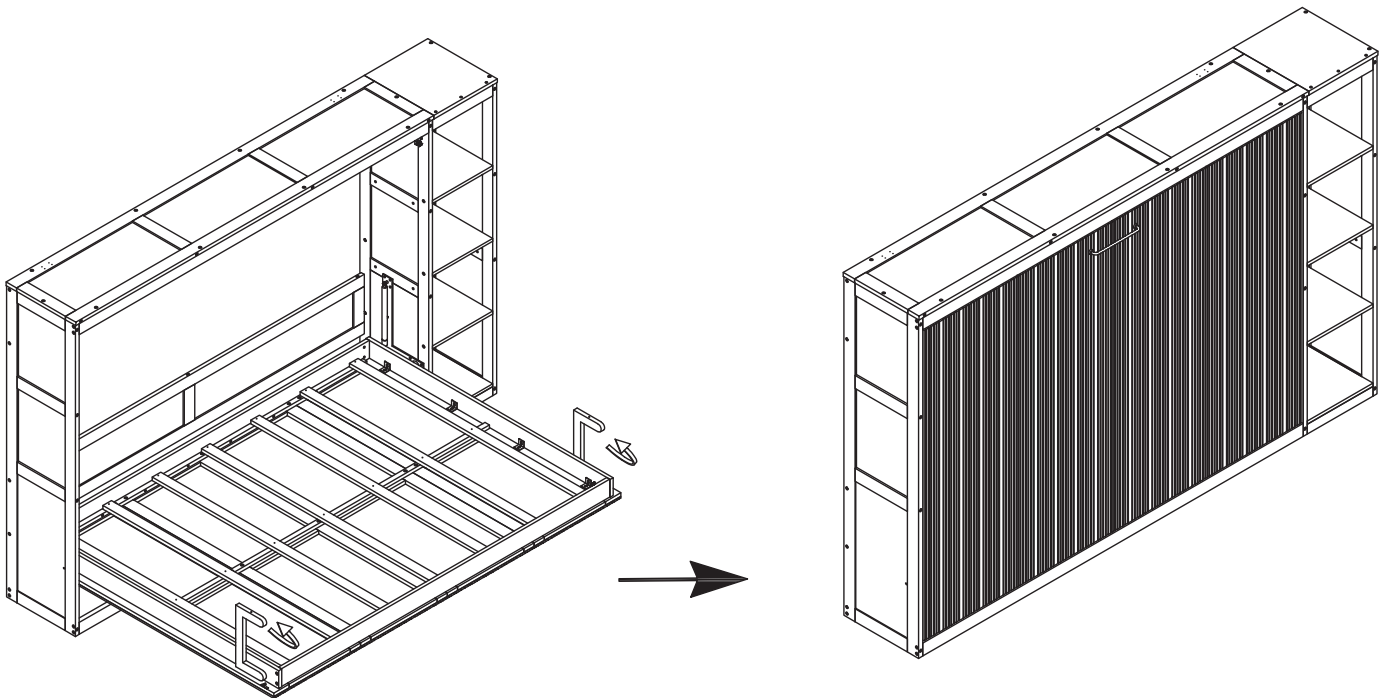

# Step 36

## Étape 36

1- Determine the position of the bed in the room

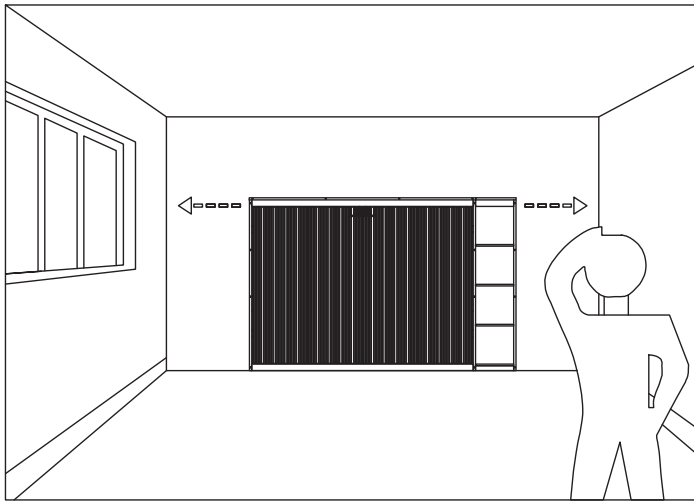

2- Put the bed black in its place. Please keep it vertical and horizontal

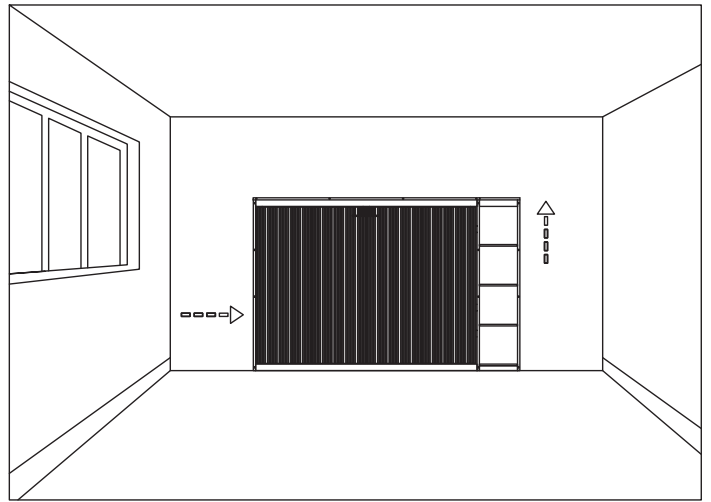



## Step 37

### Étape 37

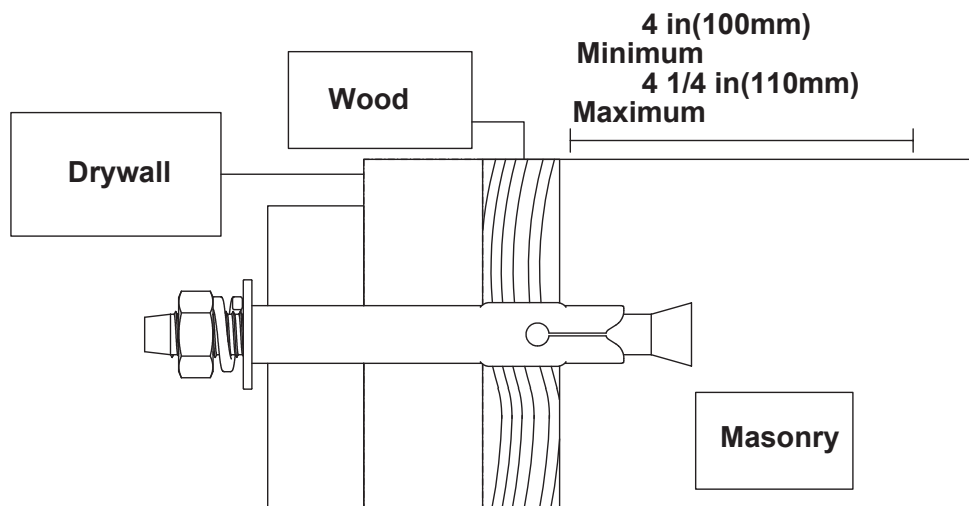
Put the bed back in its place. Put the **CONCRETE SCREWS** 3/8"(10mm) diameter X **APPROPRIATE LENGTH** into the holes of part #2 and screw the bed onto the masonry wall until tight against the wall. Screw must be at least 4"(100mm) deep into masonry. **USE AN ELECTRIC SCREWDRIVER WITH AN ADJUSTABLE TENSION CLUTCH THAT HELPS PREVENT OVER-TIGHTENING AND STRIPPING.**



**Step 38**  
**Étape 38**

<b>P</b>		<b>O2</b>	
4SETS		2PCS	

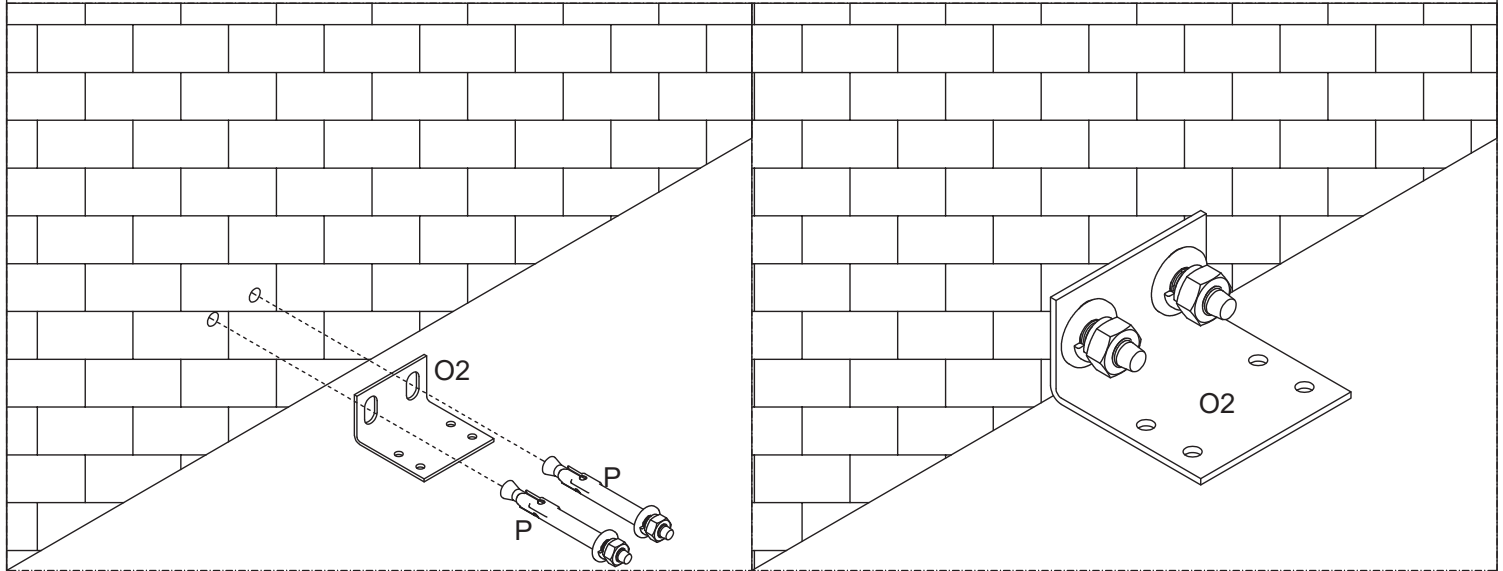

**Step 39**  
**Étape 39**

 Requires 4 people to assemble  
(2 people hold the large cabinet  
in place and 2 people tilt the bed  
until accessories are in place)

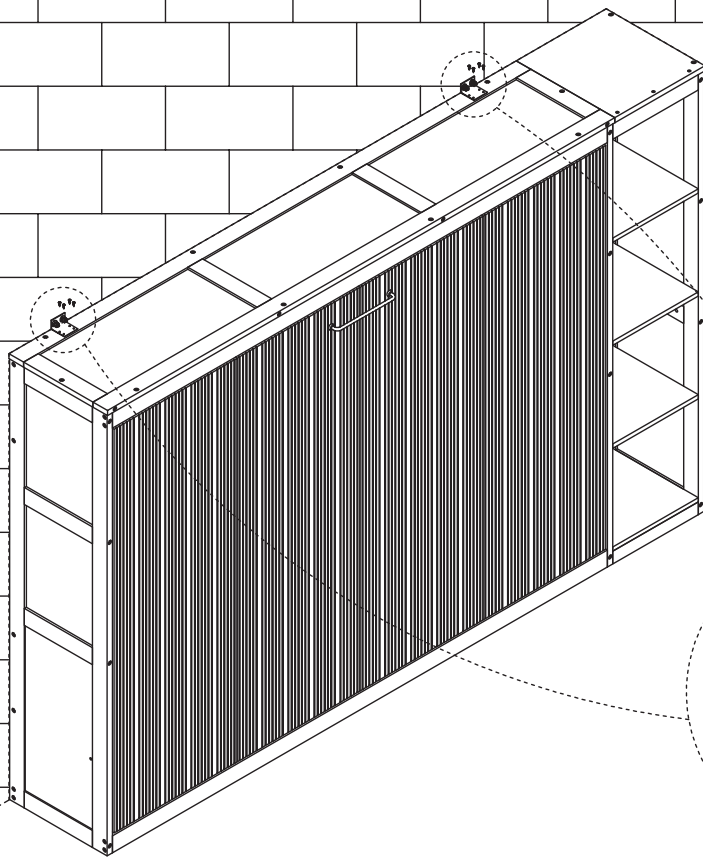

**Q**



8PCS

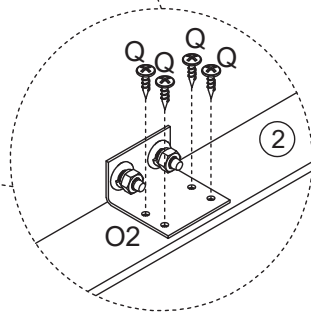

**Step 40**  
**Étape 40**

