

Asia Sideboard 4 Doors

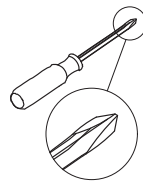
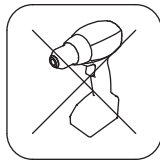
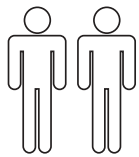
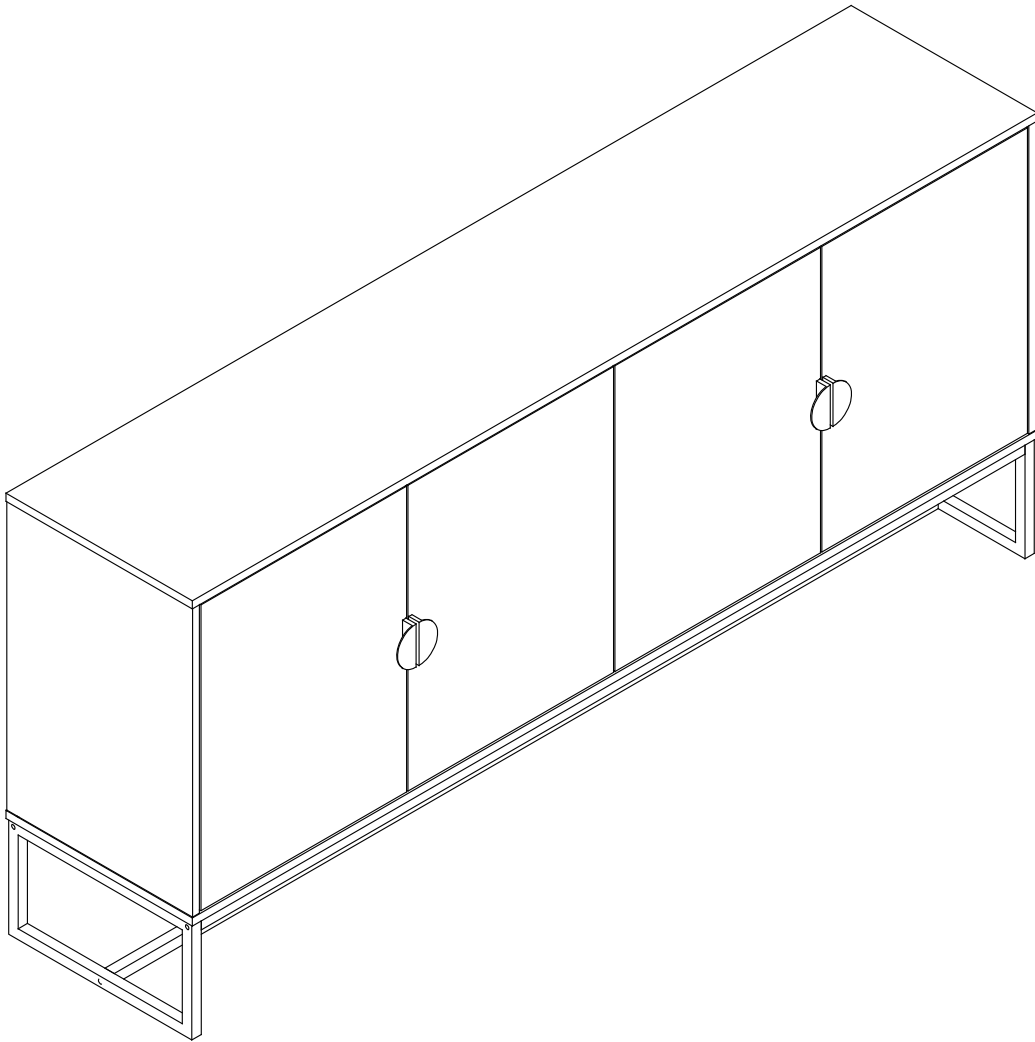

(D) Montageanleitung

(GB) Assembly instructions

(FR) Notice de montage

(IT) Istruzioni di montaggio

(NL) Handleiding voor de montage

(PL) Instrukcja montażu

(CZ) Montážní návod

(SK) Návod na montáž

(HU) Szerelési útmutató

(RO) Instrucțiuni de montaj

(TR) Montaj talimati

(RU) Инструкция по монтажу

**Service • Assistenza • Dienstverlening • Serwis
Servis • Szerviz • Сервисная служба**

Name • Nom • Nome • Naam • Nazwa • Jméno • Názov • Név • Denimire • İsim • Название	
Nr. • No. • N° • Номер • Ć • Sz	
Typ • Type • Tip • Típus • Tipo • Тип	
	

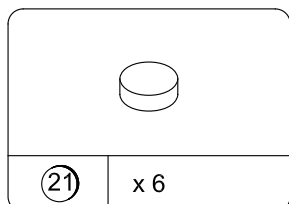
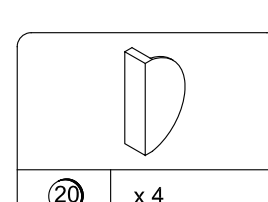
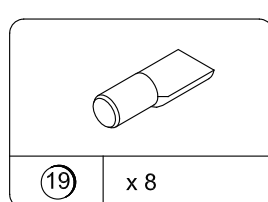
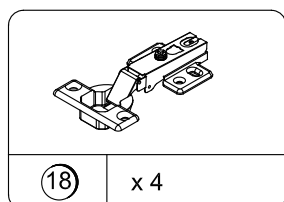
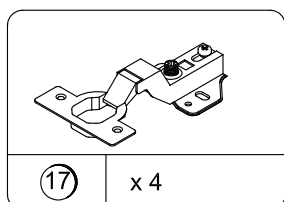
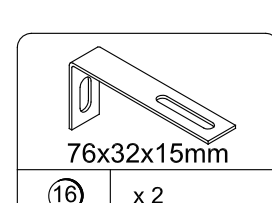
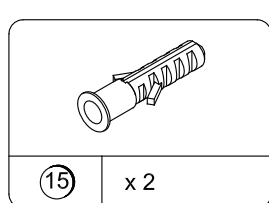
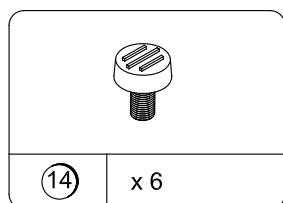
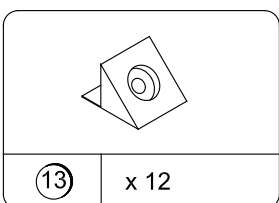
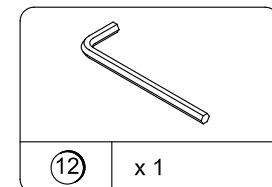
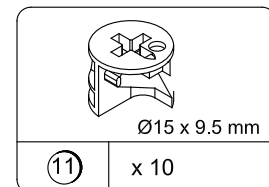
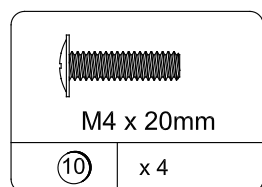
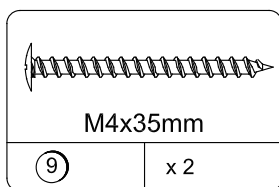
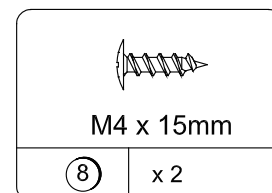
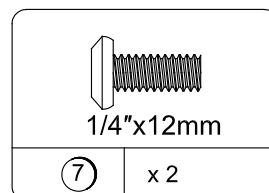
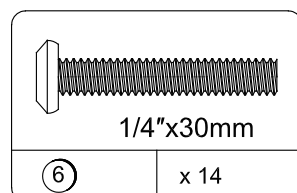
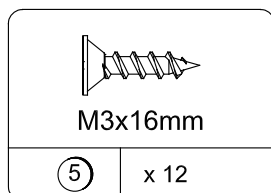
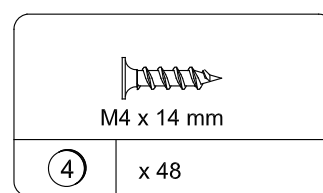
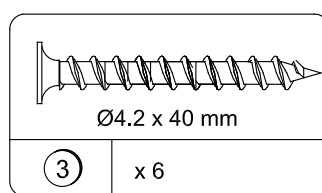
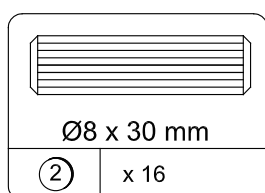
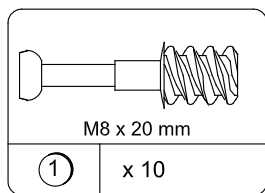
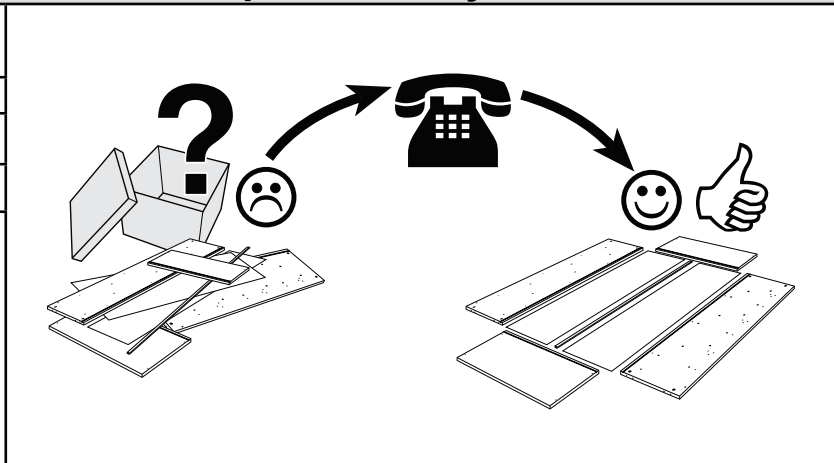
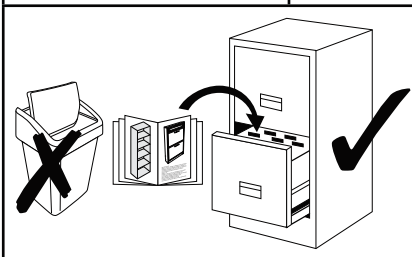

teil / part / partie / parte / deel / część/ část / část' / rész / parte / parça / Часть	anzahl / number / nombre / numero / nummer / numer / číslo / číslo / szám / număr / sayı / Число	paket / package / emballer / pacchetto / pakket / pakiet / balík / balík / csomag / pachet / paket / Упаковка
A	1	1/2
B	1	1/2
C	1	1/2
D	1	2/2
E	1	2/2
F	2	2/2
G	2	1/2
H	2	1/2
I	3	1/2
K	1	2/2
L	2	2/2
M	2	1/2
N	1	1/2
107110XX	1	2/2

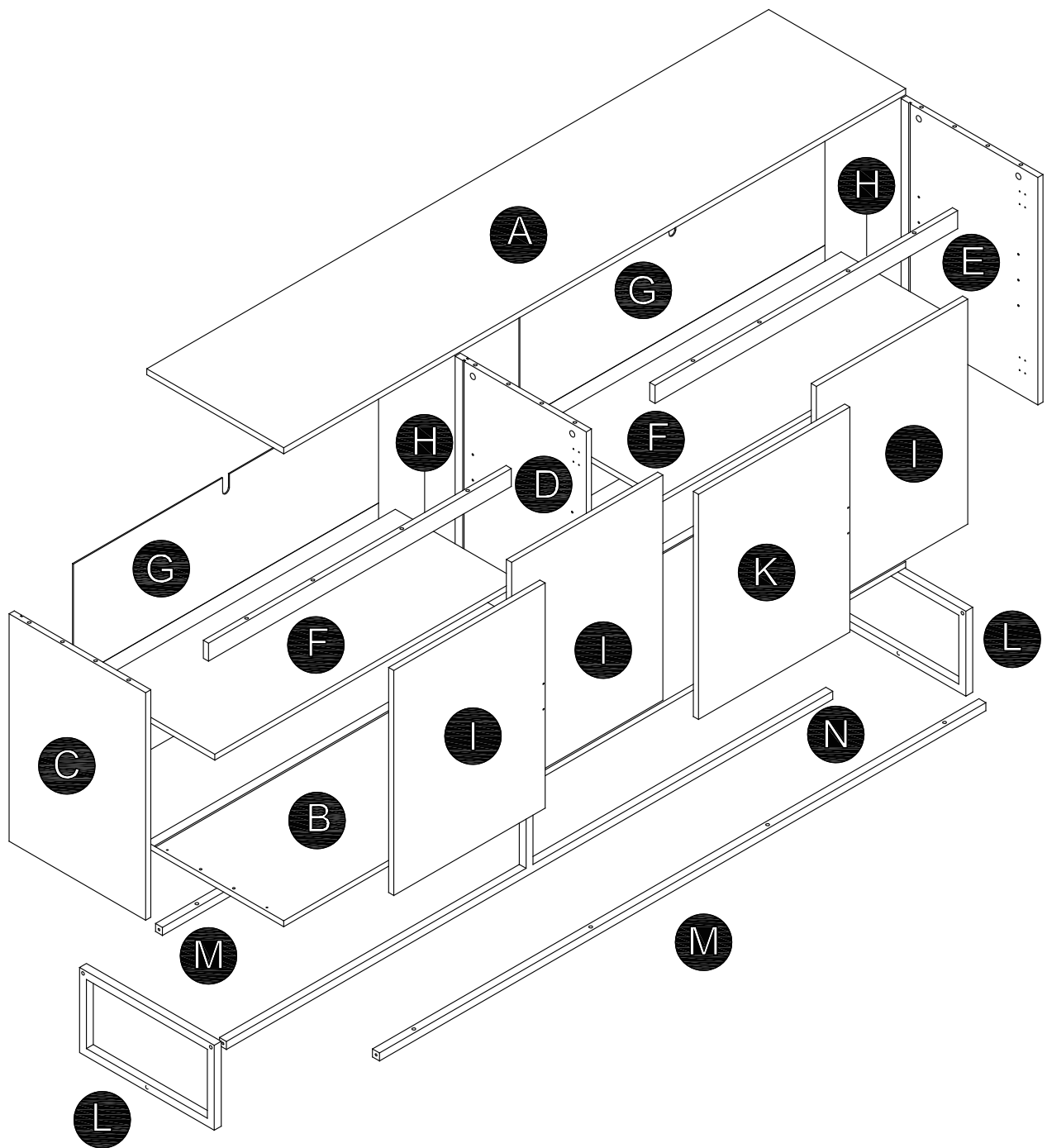

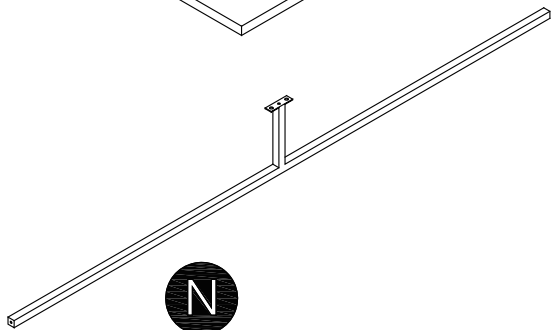
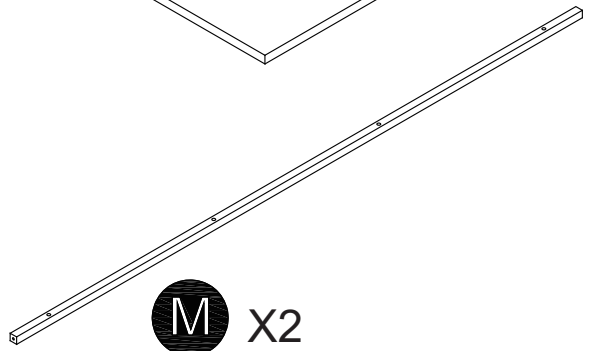
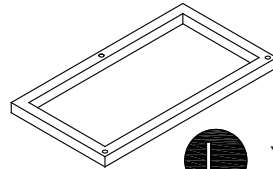
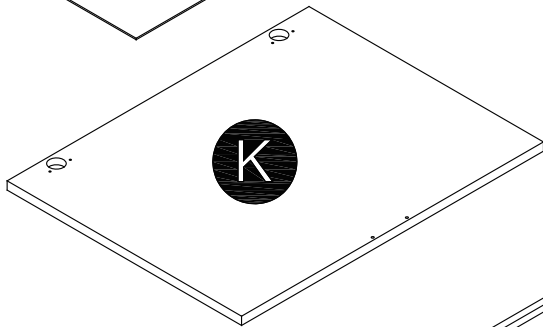
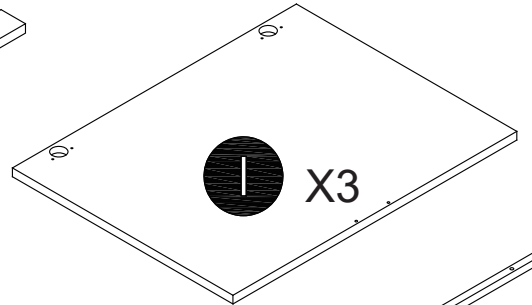
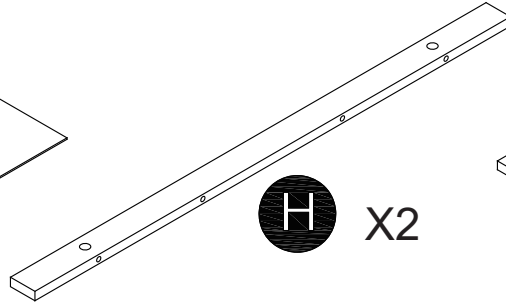
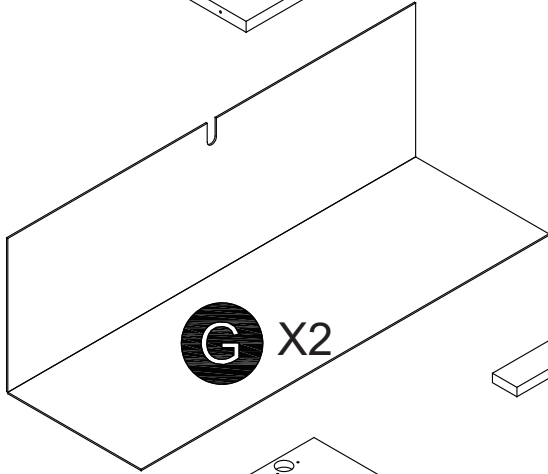
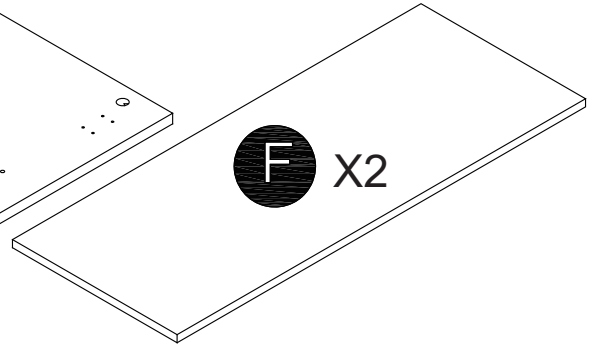
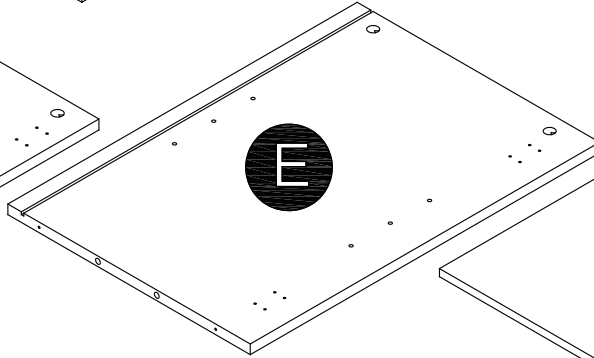
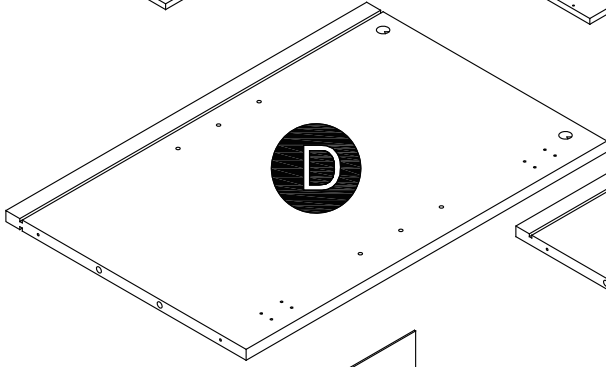
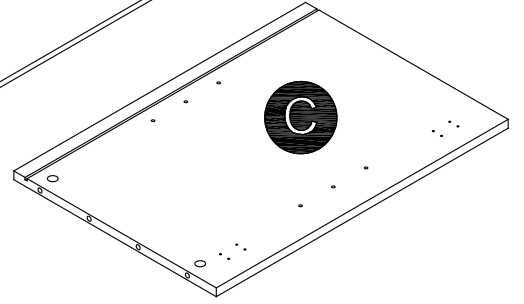
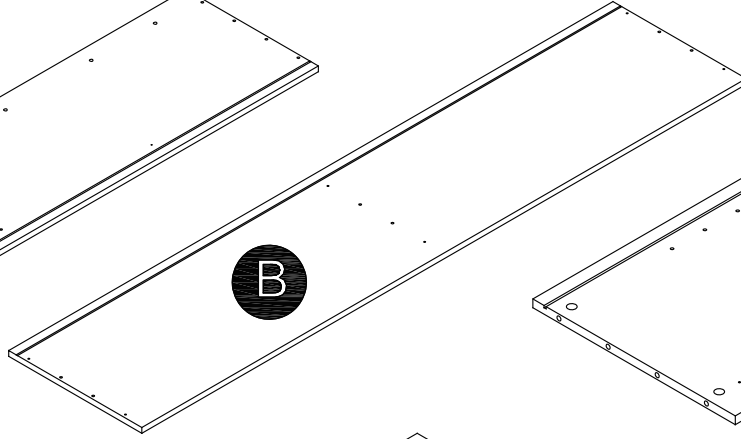
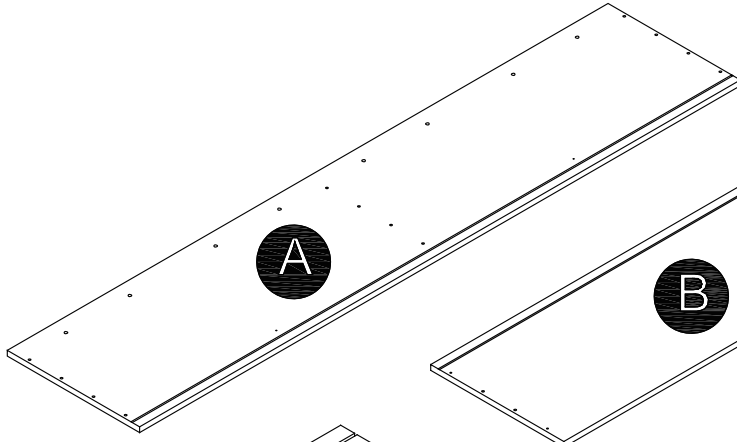
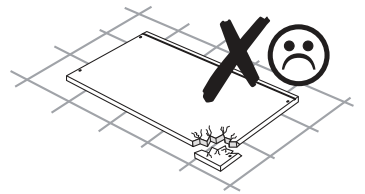
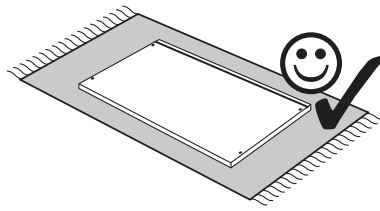
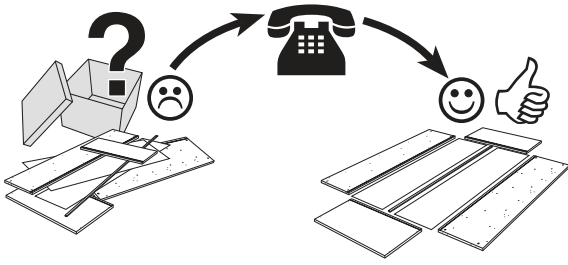

1

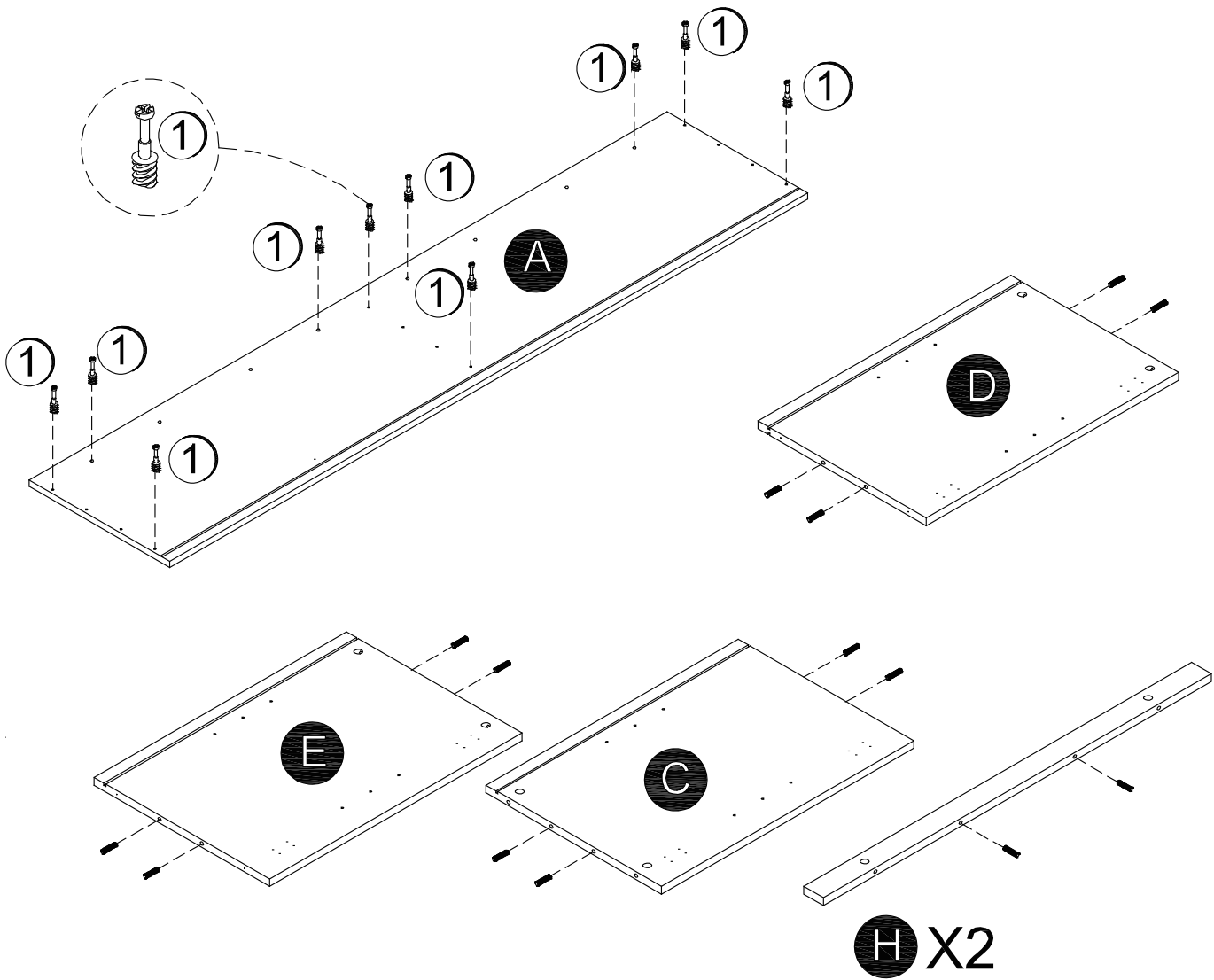
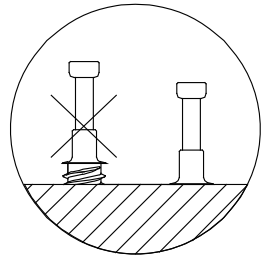
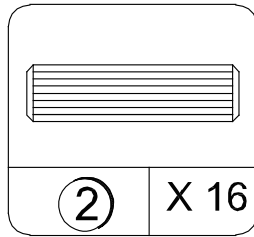
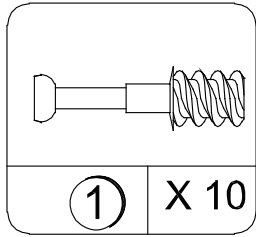
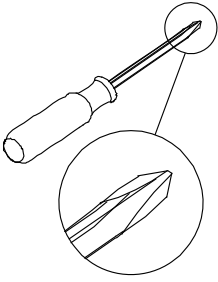

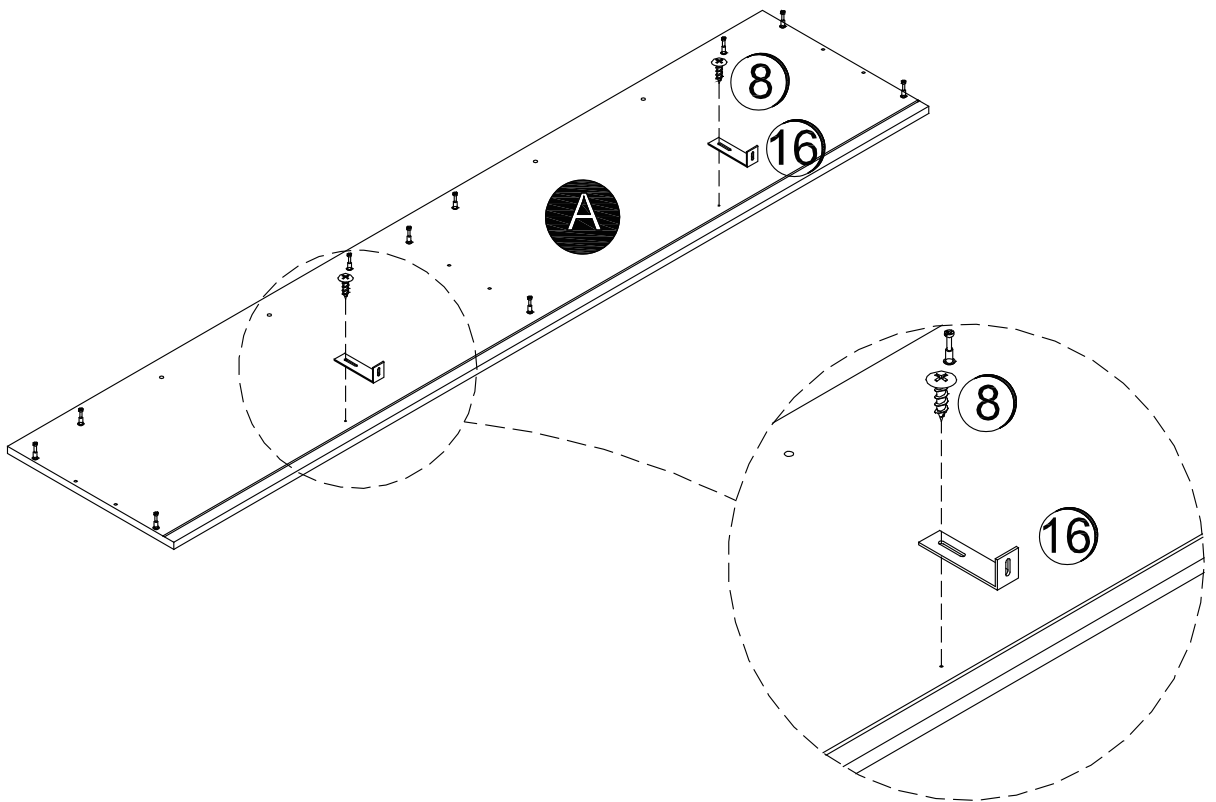
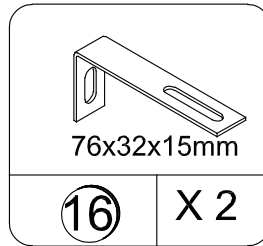
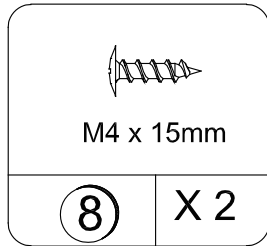
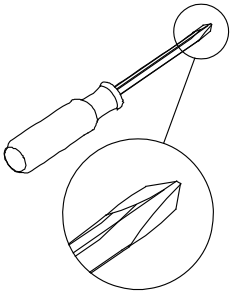

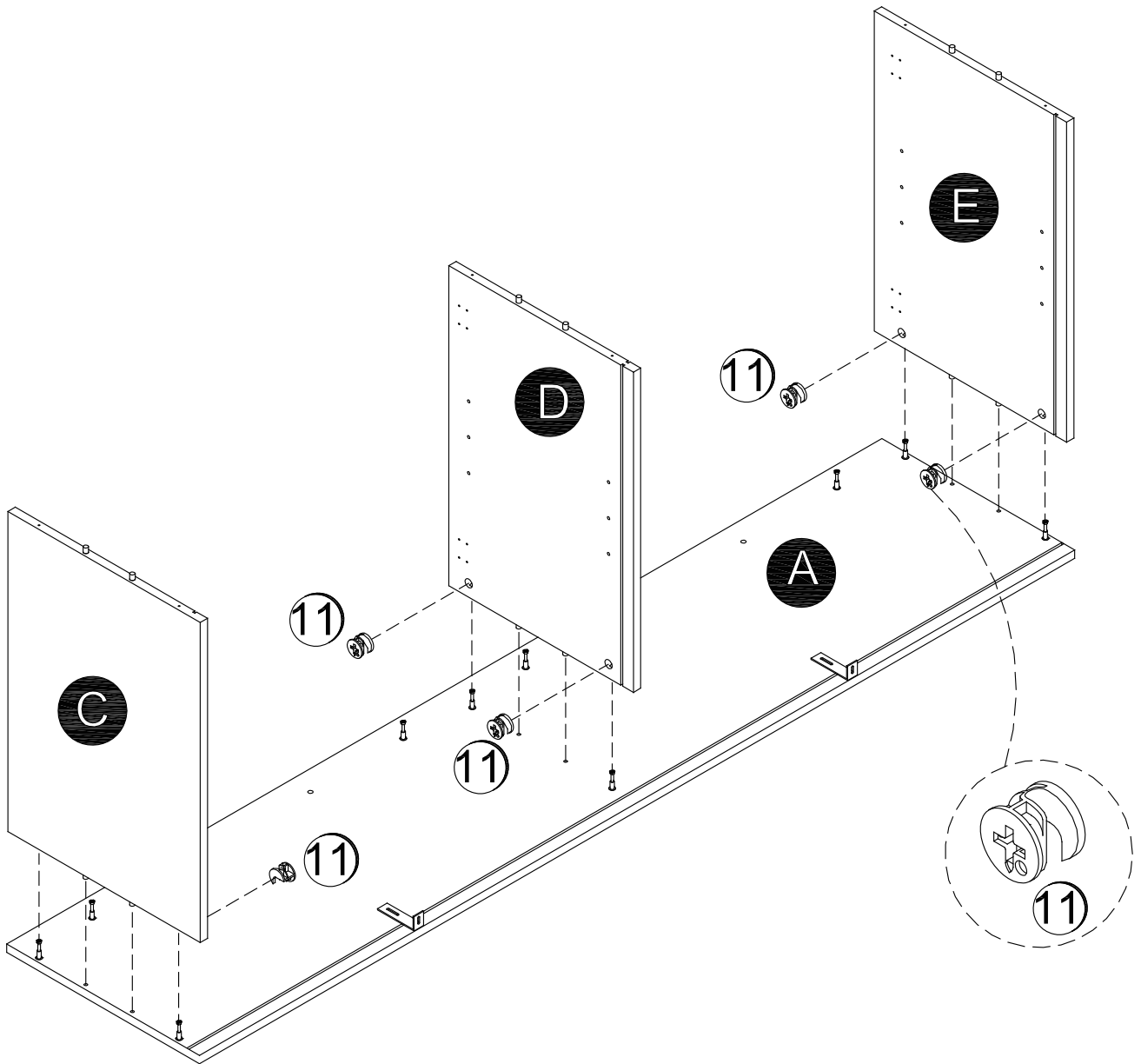
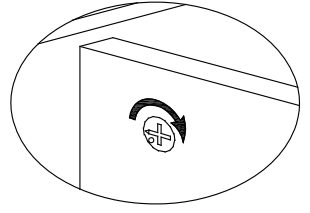
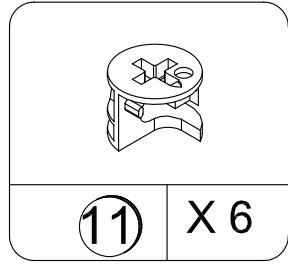
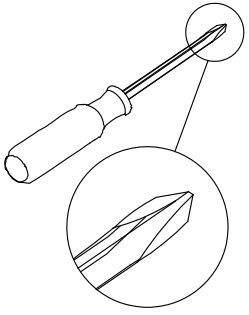

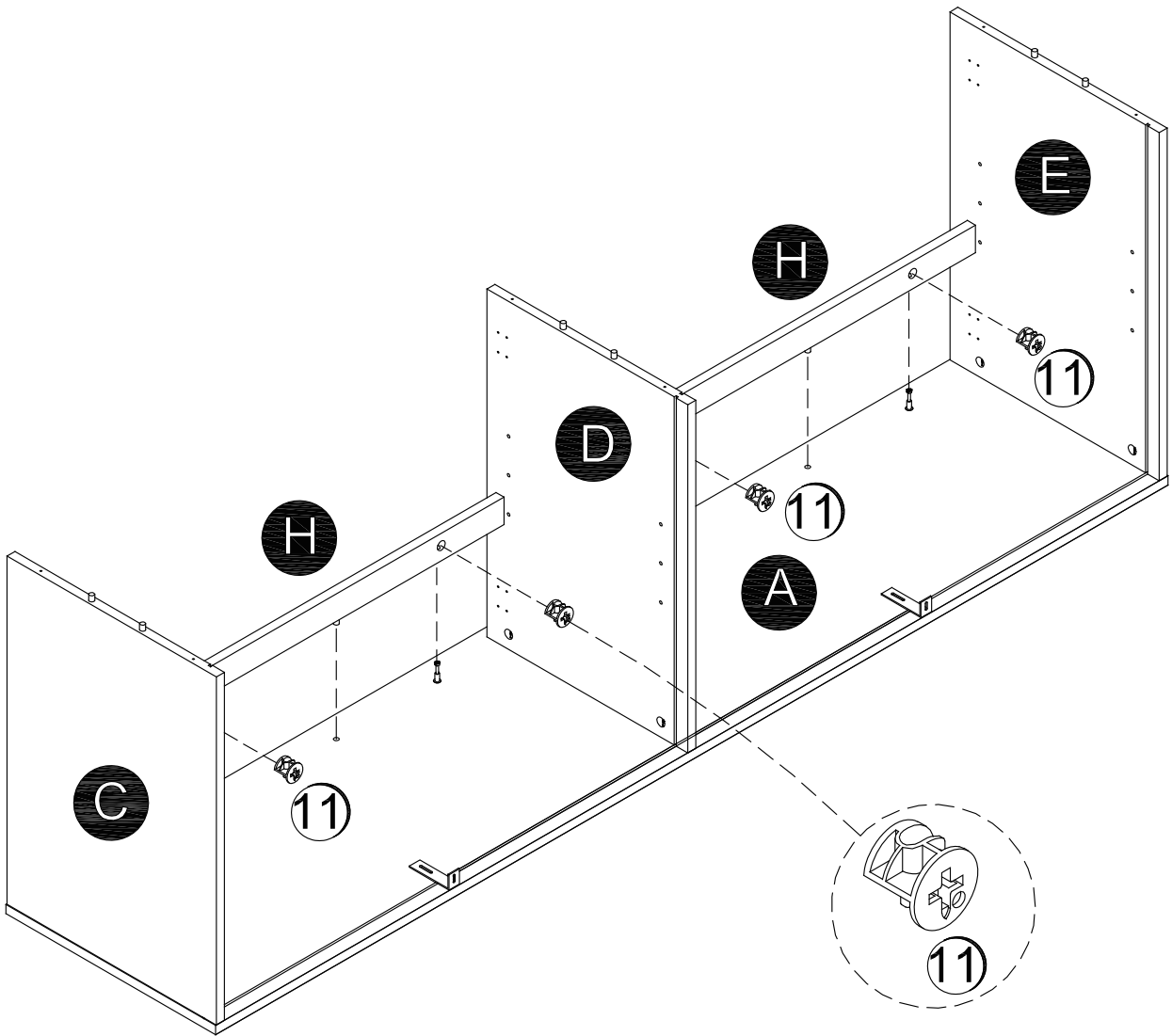
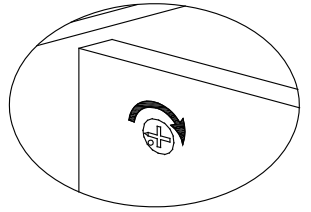
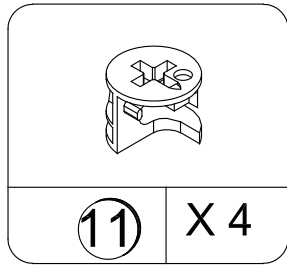
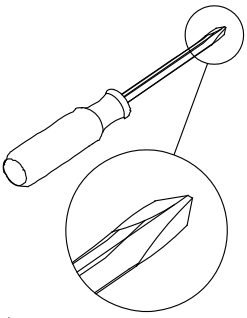

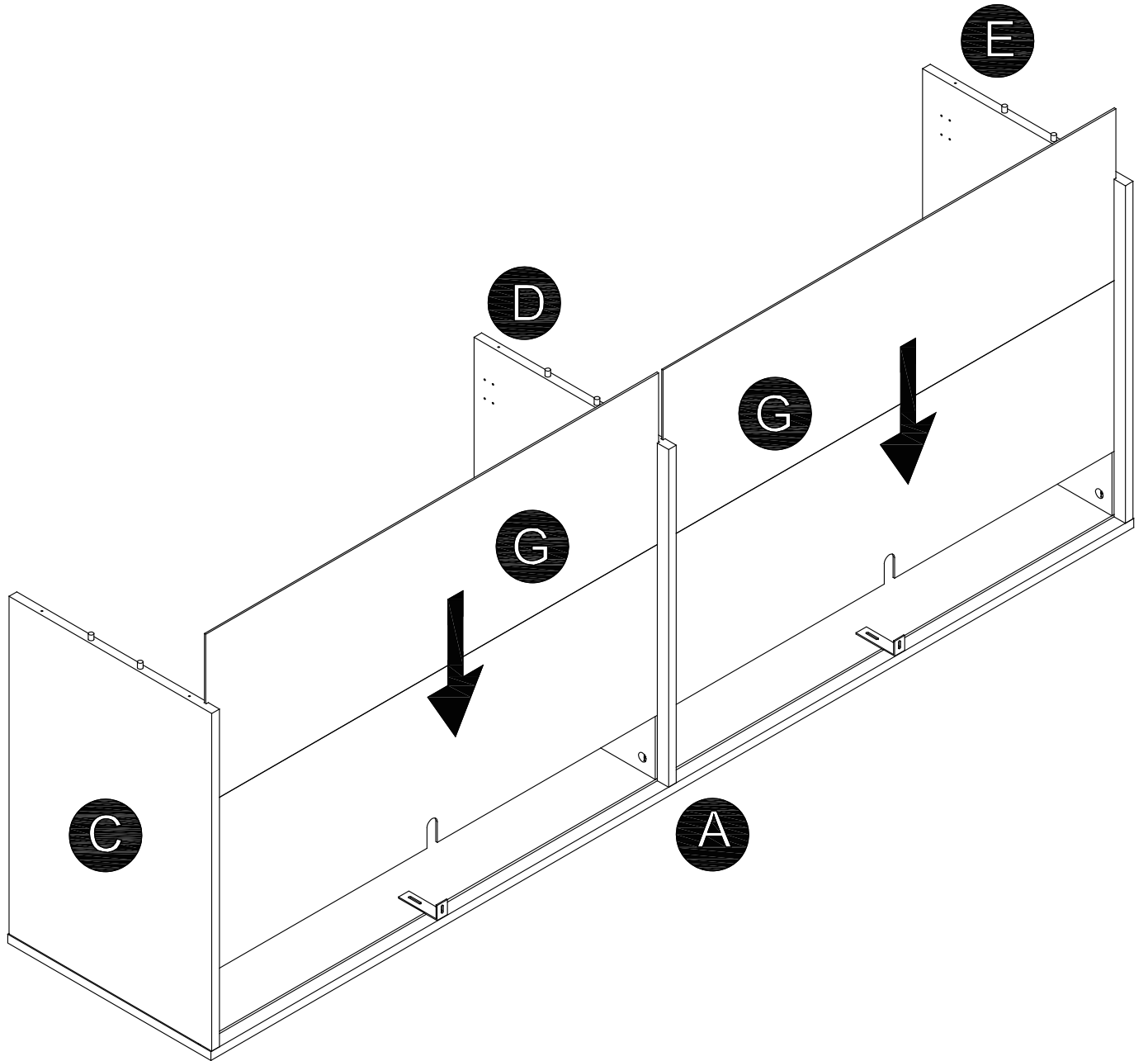

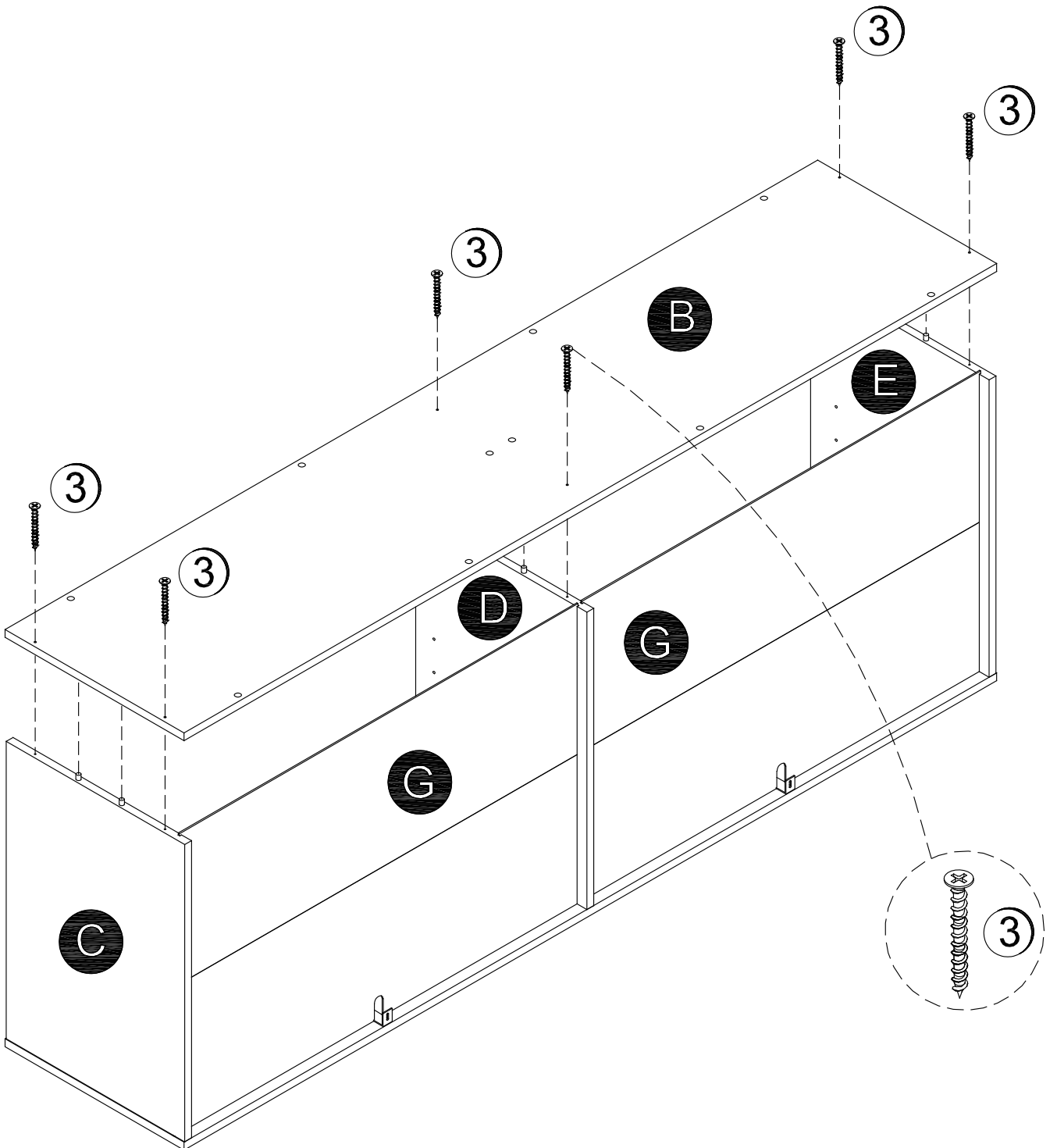
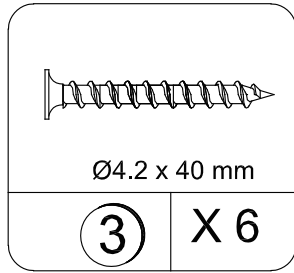
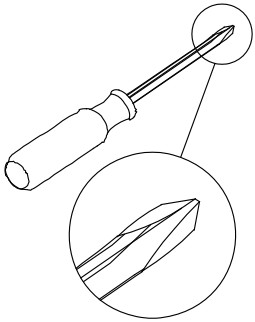

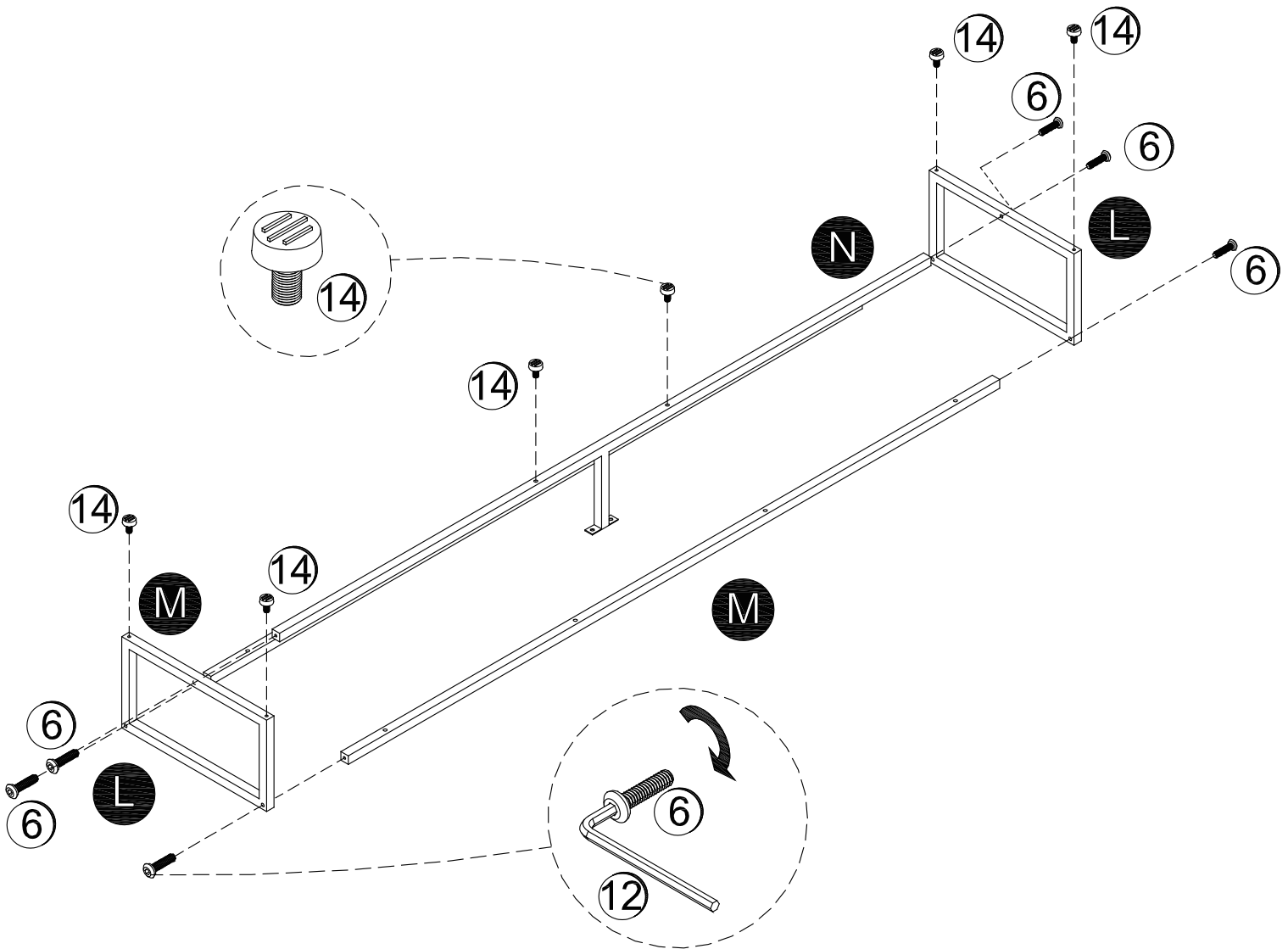
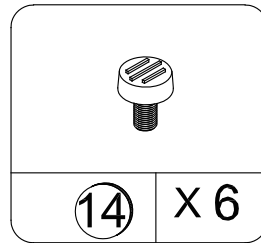
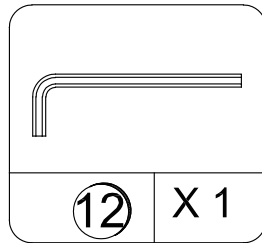
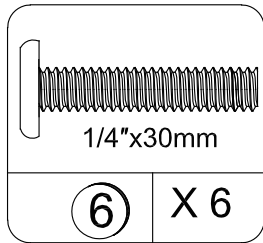

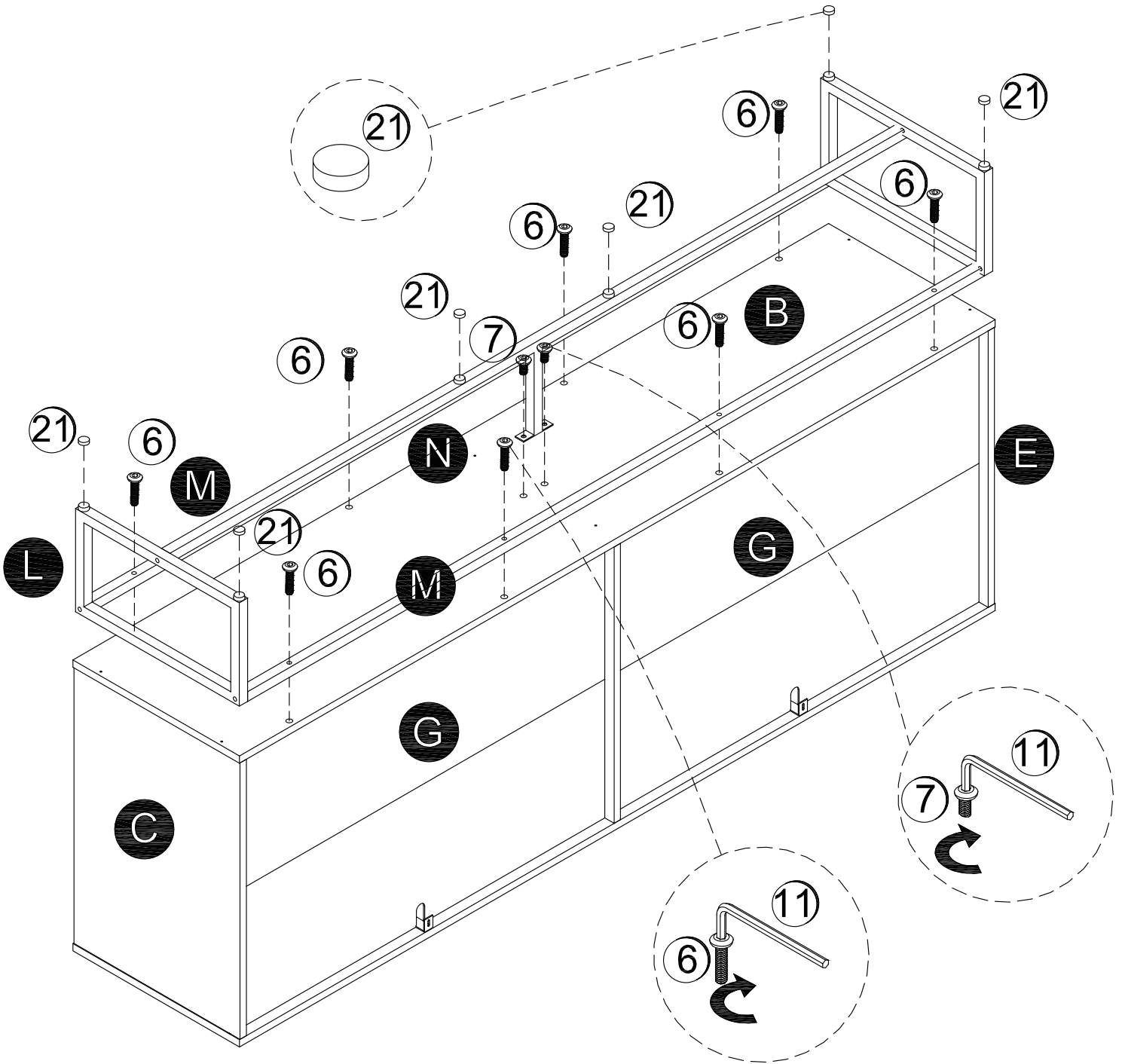
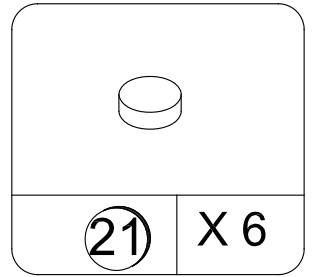
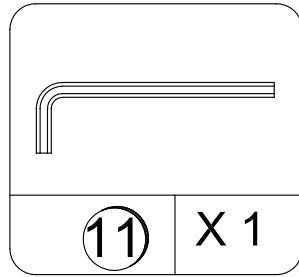
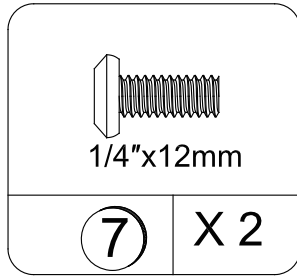
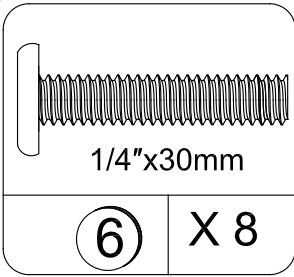

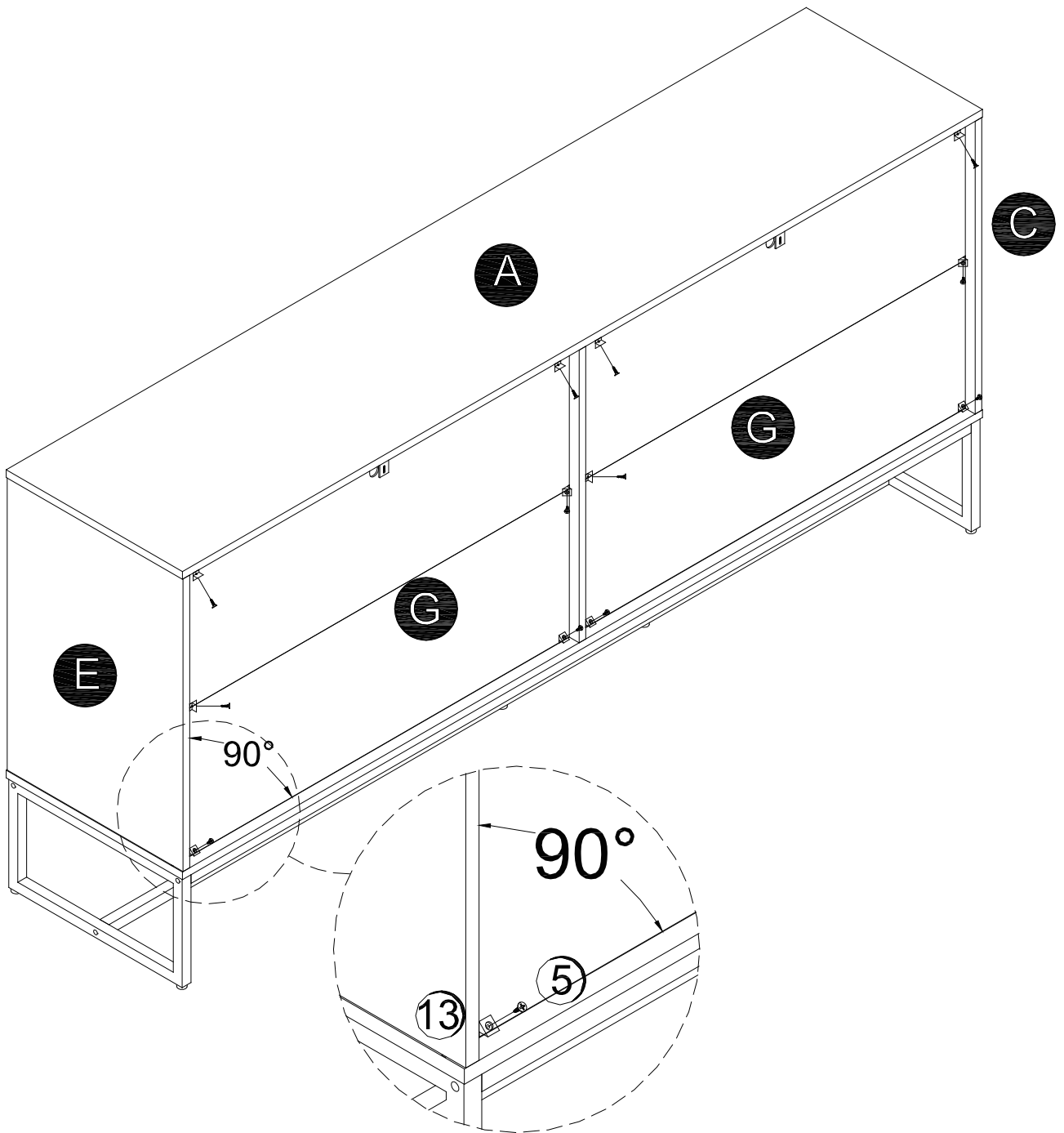
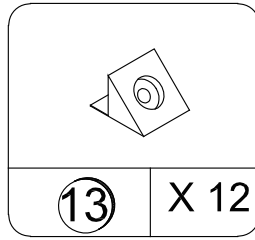
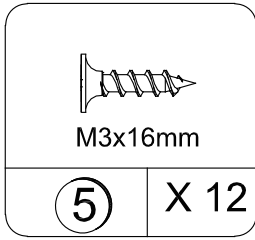
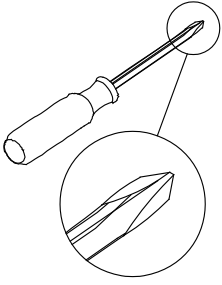

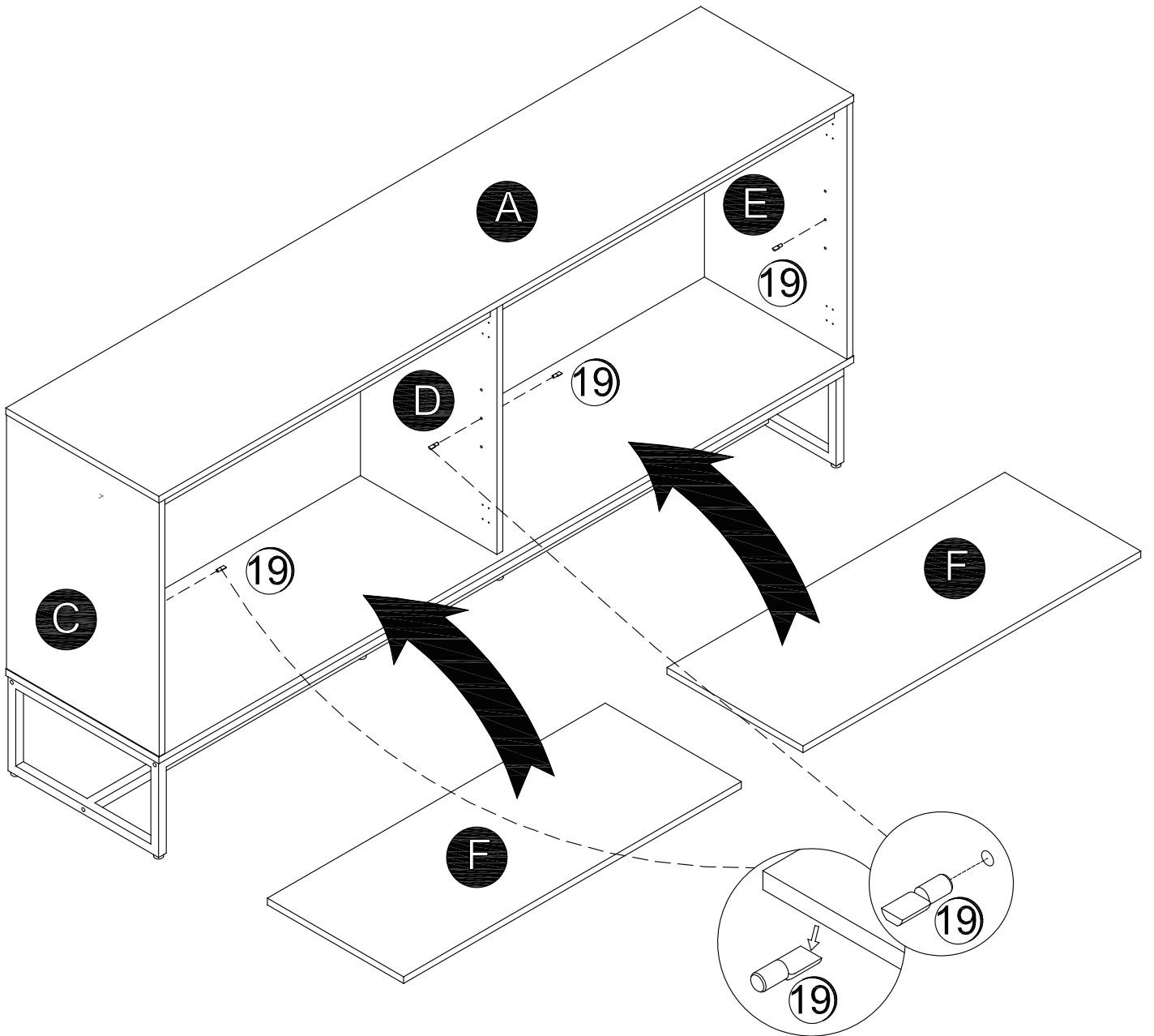
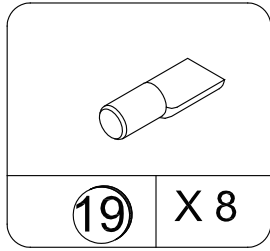

11

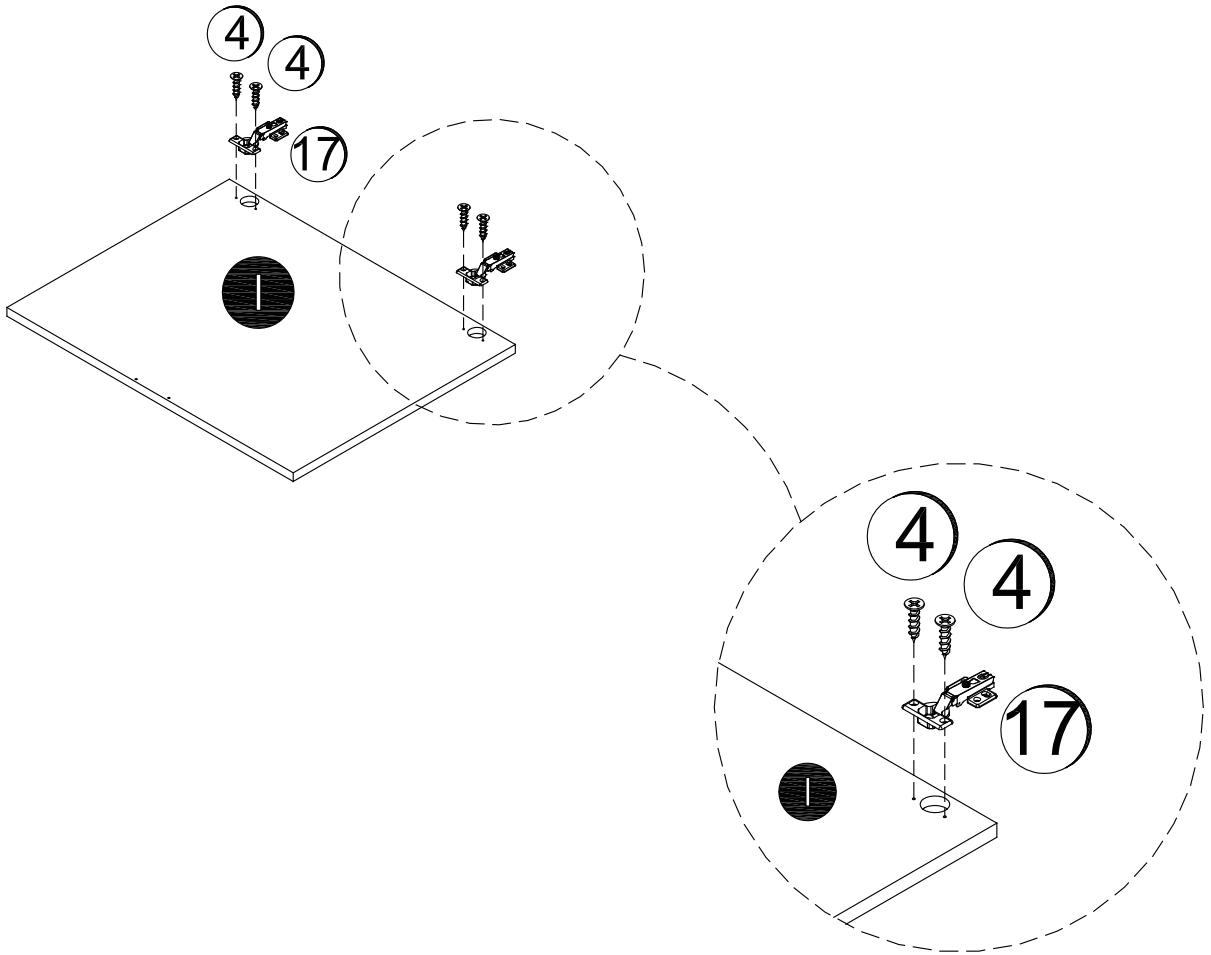
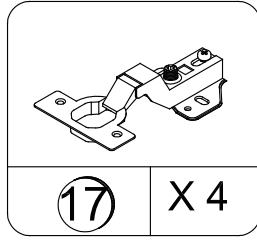
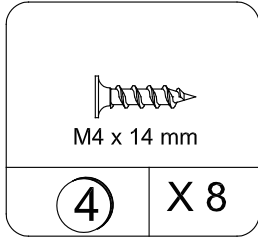
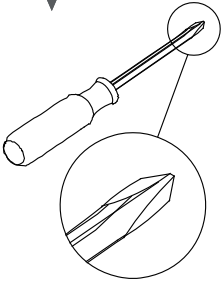

X2

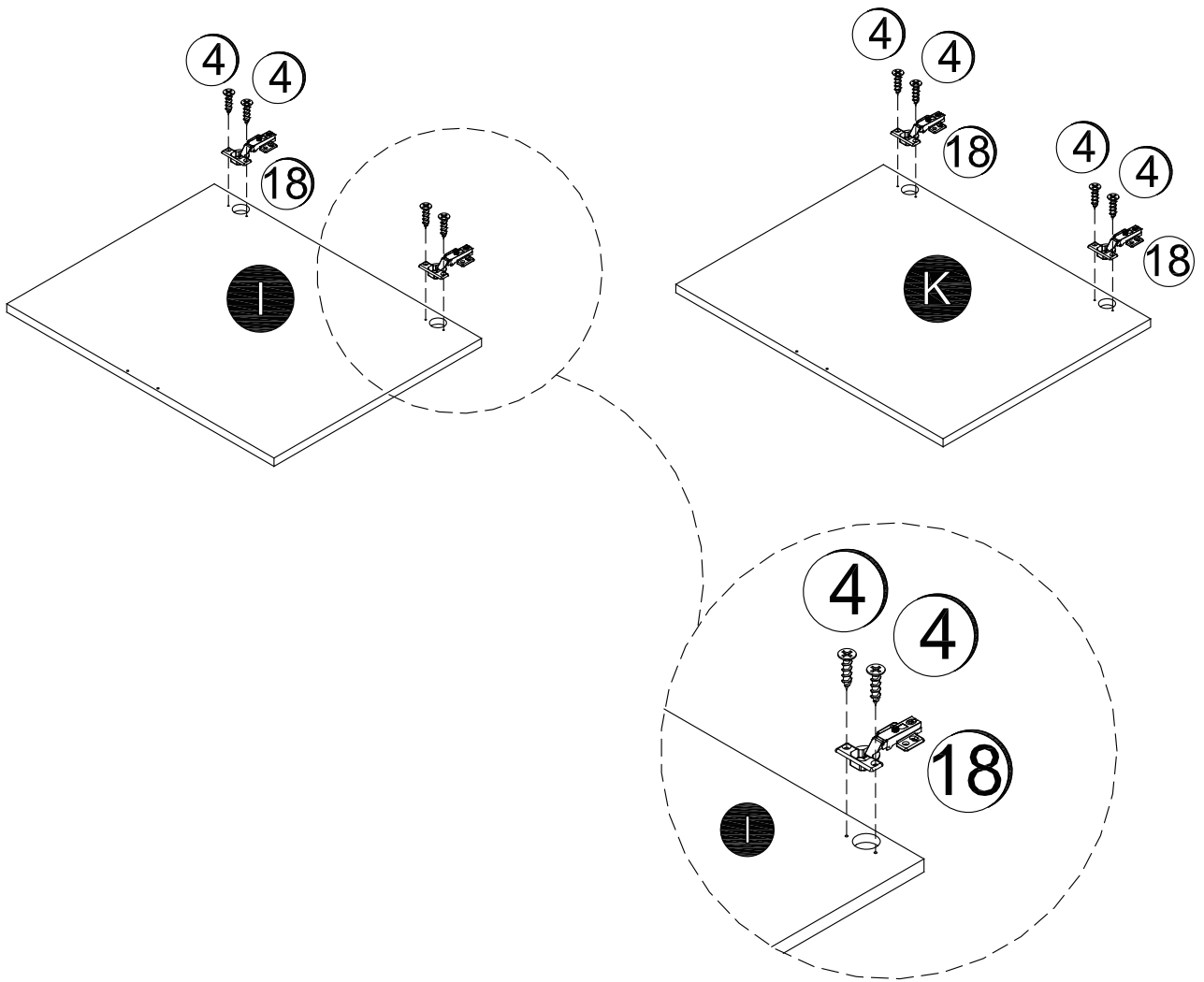
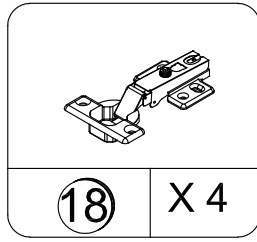
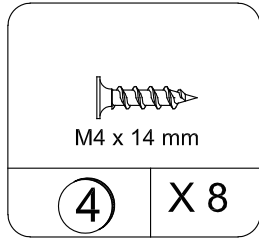
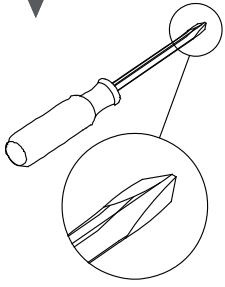

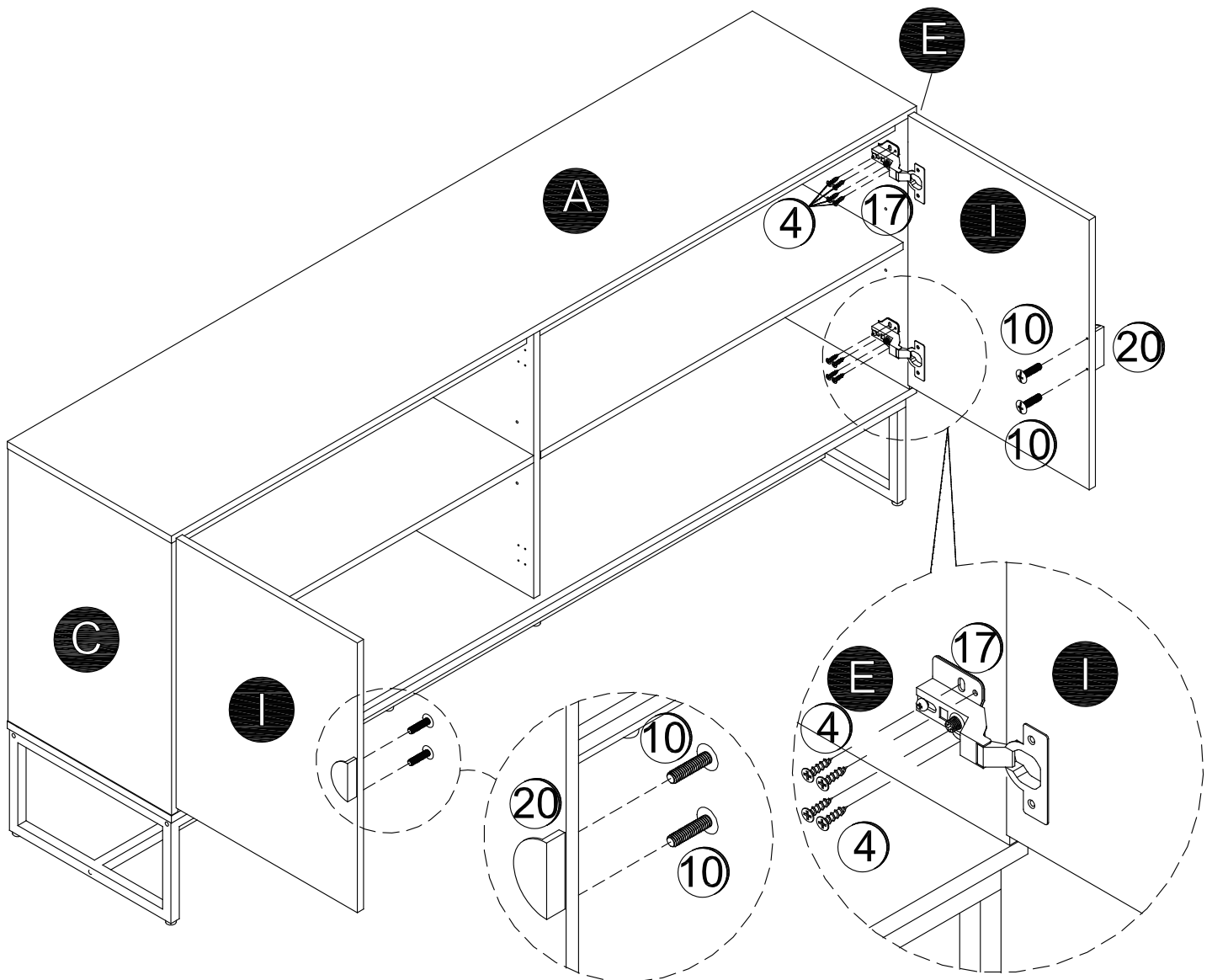
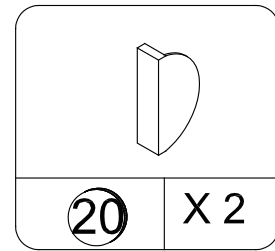
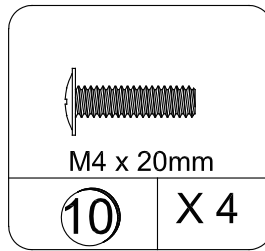
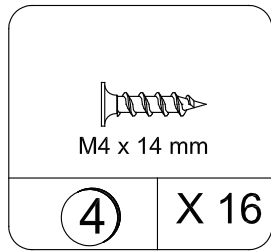
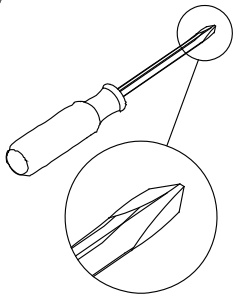

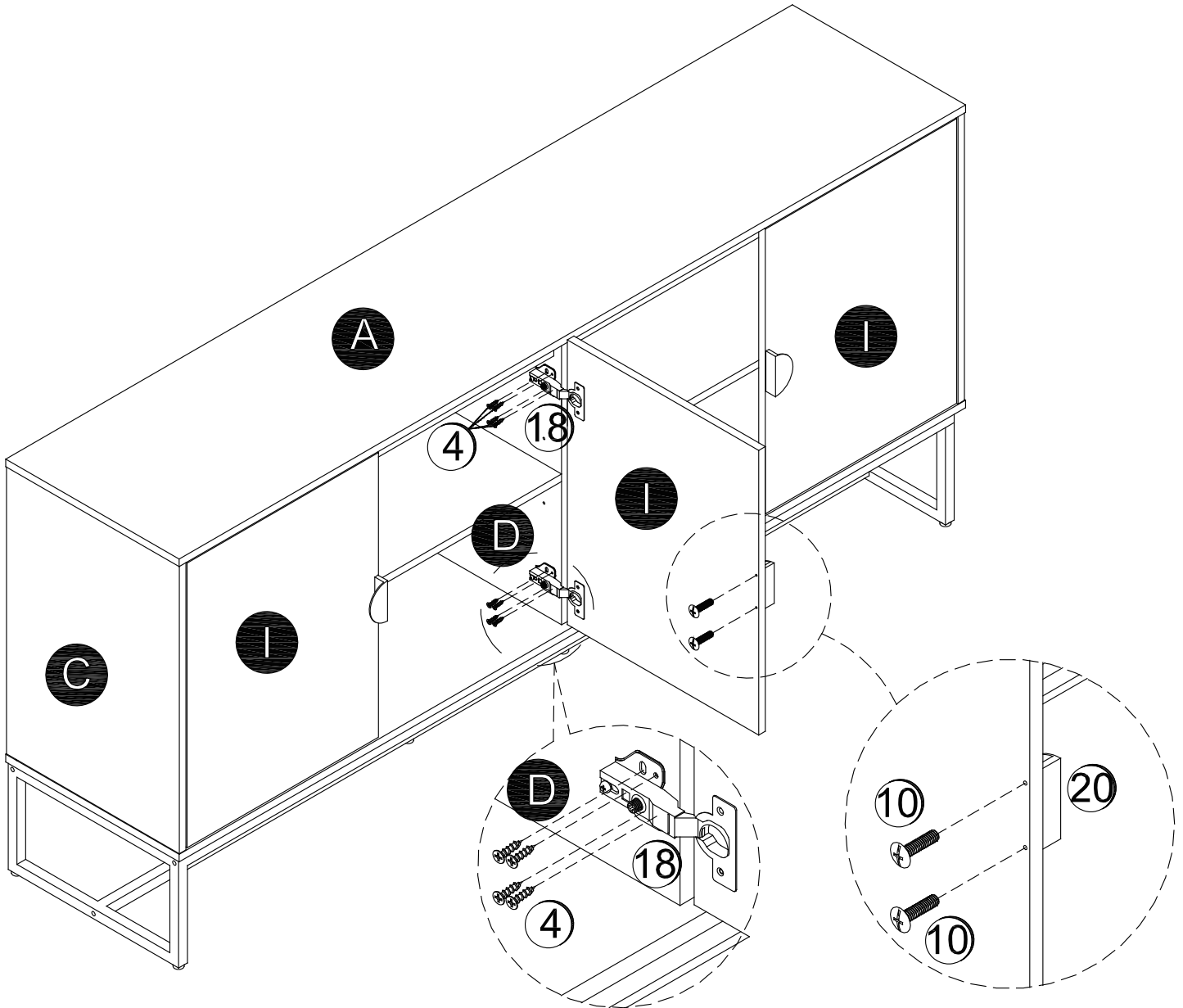
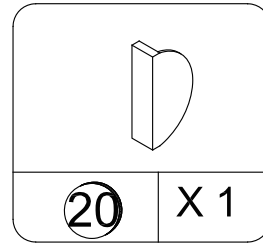
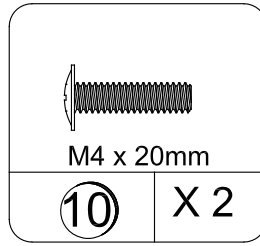
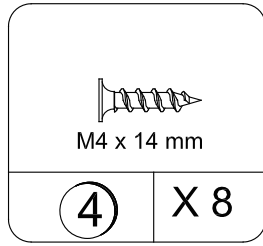
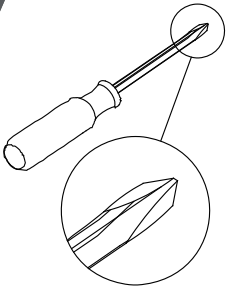

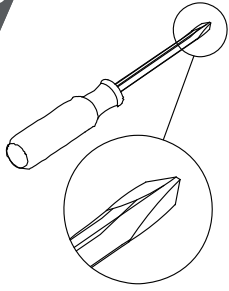

15

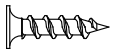

 M4 x 14 mm	
4	X 8

 M4 x 20mm	
10	X 2

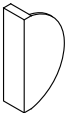
	
20	X 1

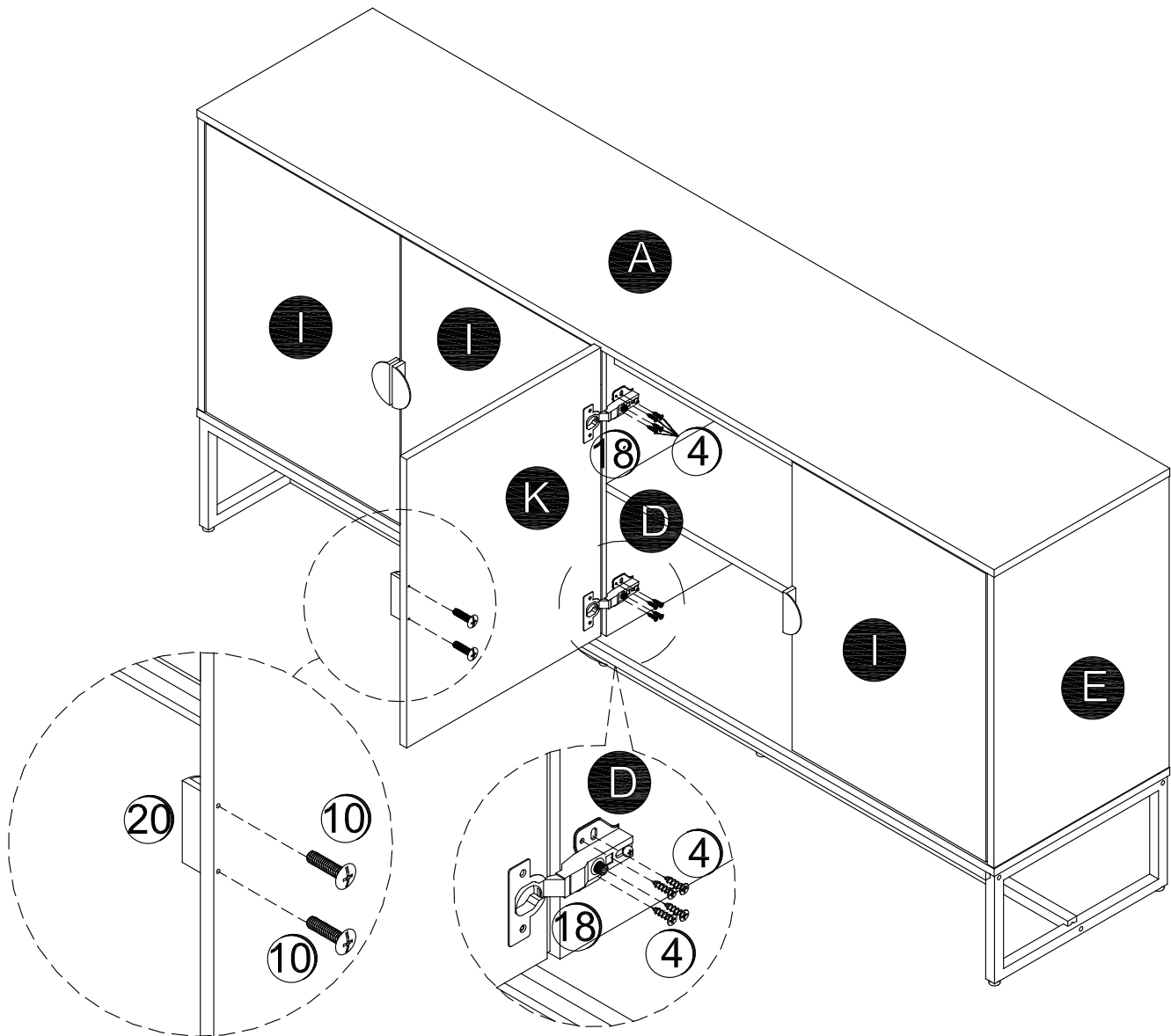

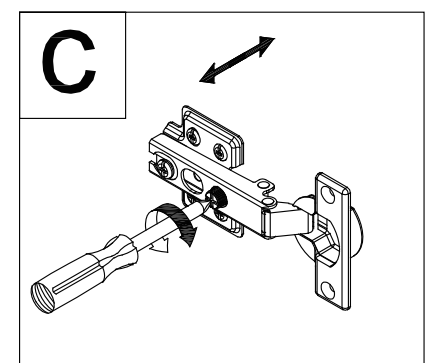
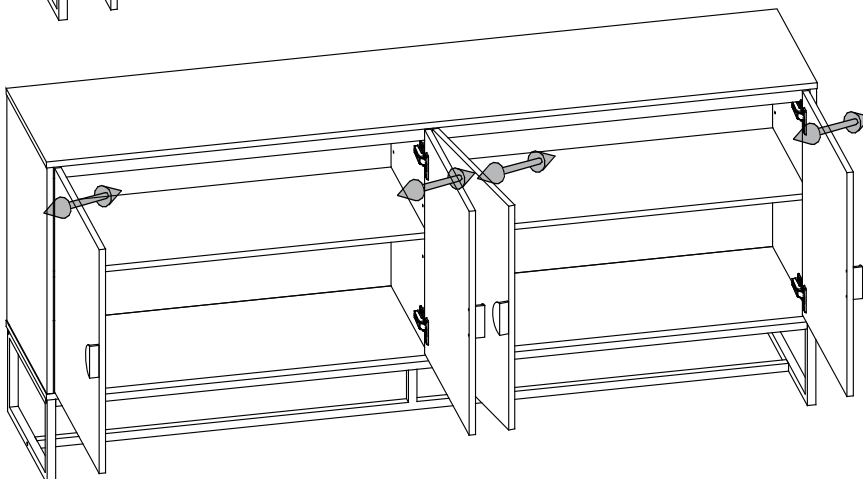
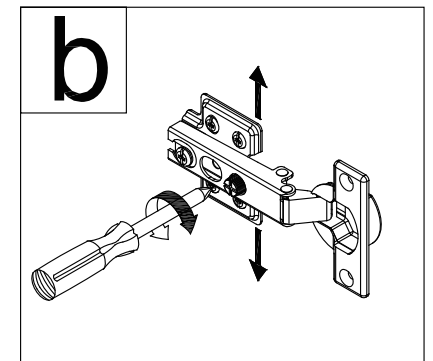
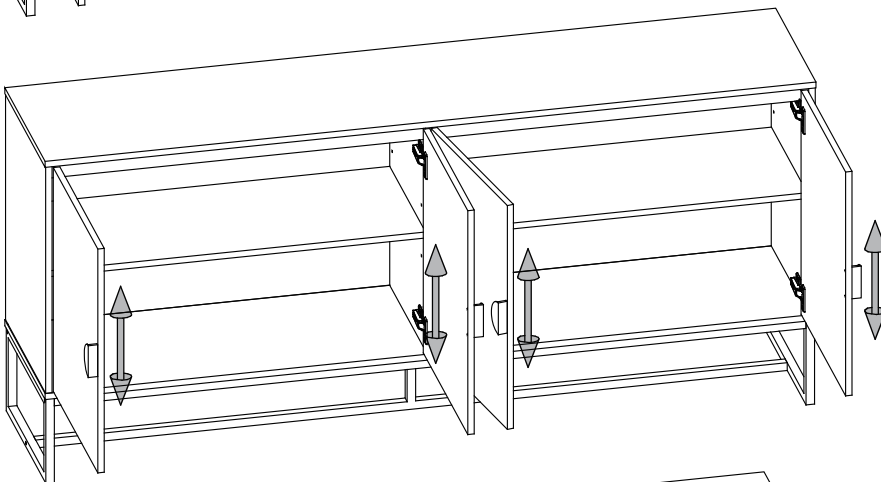
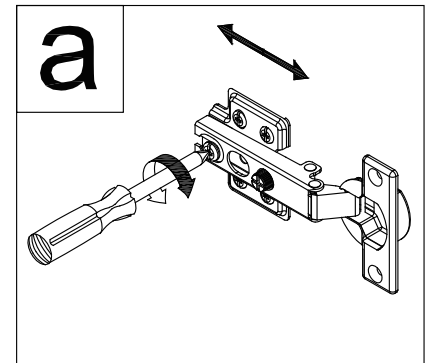
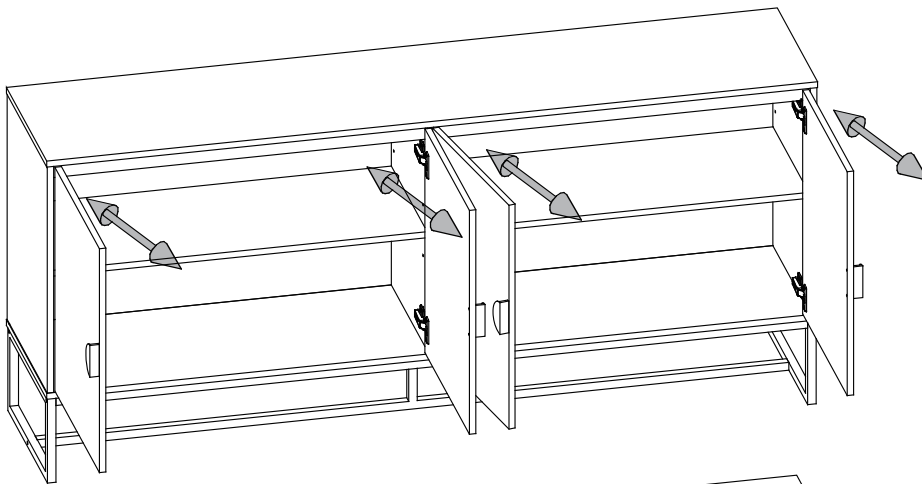

! Achtung • Attention • Attenzione • Opgelet • Uwaga • Pozor • Figyelem • Atenție •
Dikkat • Внимание **!**

(D)	Türen einstellen (Scharniere justieren)
(GB)	Adjusting the doors (adjusting the hinges)
(NL)	Deuren instellen (scharnieren afstellen)
(PL)	Nastawić drzwi (wyrównać zawiasy)
(TR)	Kapıların ayarlanması (menteşelerin seviye ayarı)
(RU)	Регулировка дверей (регулировка шарнира)
(FR)	Régler les portes (ajuster les charnières)
(IT)	Sistemare le porte (regolare le cerniere)
(CZ)	Vyrovnejte dvířka (seřid'te závěsy)
(SK)	Nastavenie dverí (nastavenie závesov)
(HU)	Állítsa be az ajtókat (állítsa be a zsanérokat)
(RO)	Reglare ușii (ajustare balamale)

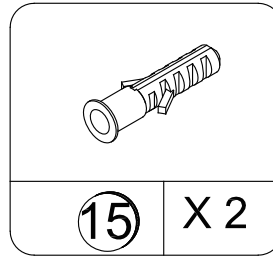
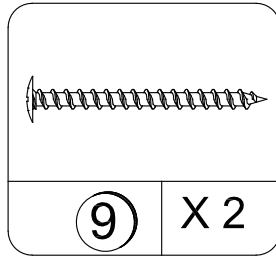
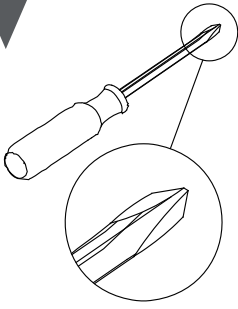



 Achtung • Attention • Attenzione • Opgelet • Uwaga • Pozor • Figyelem Atenție • Dikkat • Внимание 			
D	Wandbefestigung dient als Kippschutz – unbedingt anbringen! Bei einigen Wandtypen kann ein Spezialdübel erforderlich sein!	CZ	Montáž na stěnu slouží jako ochrana proti převrnutí – bezpodmínečně umístěte! U některých typů stěn může být zapotřebí speciální hmoždinka!
GB	The wall fastening serves to prevent tipping – be absolutely sure to mount it! For certain wall types, a special wall plug may be necessary!	SK	Upevnenie na stenu slúži ako ochrana proti prevráteniu – bezpodmienečne použite! Pre niektoré druhy stien môže byť potrebná špeciálna hmoždinka!
FR	La fixation murale sert de protection contre le basculement – à installer impérativement ! Pour certains types de murs il faut des chevilles spéciales !	HU	A terméket a falhoz kel rögzíténi, különben az felborulhat! Egyes fatípusoknál speciális tiplit kell használni!
IT	Il fissaggio alla parete serve da protezione anti-ribaltamento – attaccarla assolutamente! Per alcune strutture di parete può essere necessario un tassello speciale!	RO	Sistemul de fixare la perete servește ca protecție la răsturnare – de montat obligatoriu! Pentru unele tipuri de pereți este posibil să fie necesar un diblu special!
NL	Bevestiging aan de muur dient als kantelbescherming – zeker en vast bevestigen! Bij enkele muurtypes is een speciale plugmisschien vereist!	TR	Duvardaki sabitleme, devrilmeye karşı bir emniyet tedbiridir ve mutlaka monte edilmelidir! Bazı duvar tiplerinde bunun için özel bir dübel gerekli olabilir!
PL	Mocowanie do ściany jest jednocześnie zabezpieczeniem przed przewróceniem – koniecznie zamontować! Do niektórych rodzajów ścian koniecznie zastosować specjalne kołki mocujące.	RU	Обязательно установите крепление на стене во избежание опрокидывания! Для некоторых типов стен может потребоваться специальный дюбель!

