

Product Installation Manual

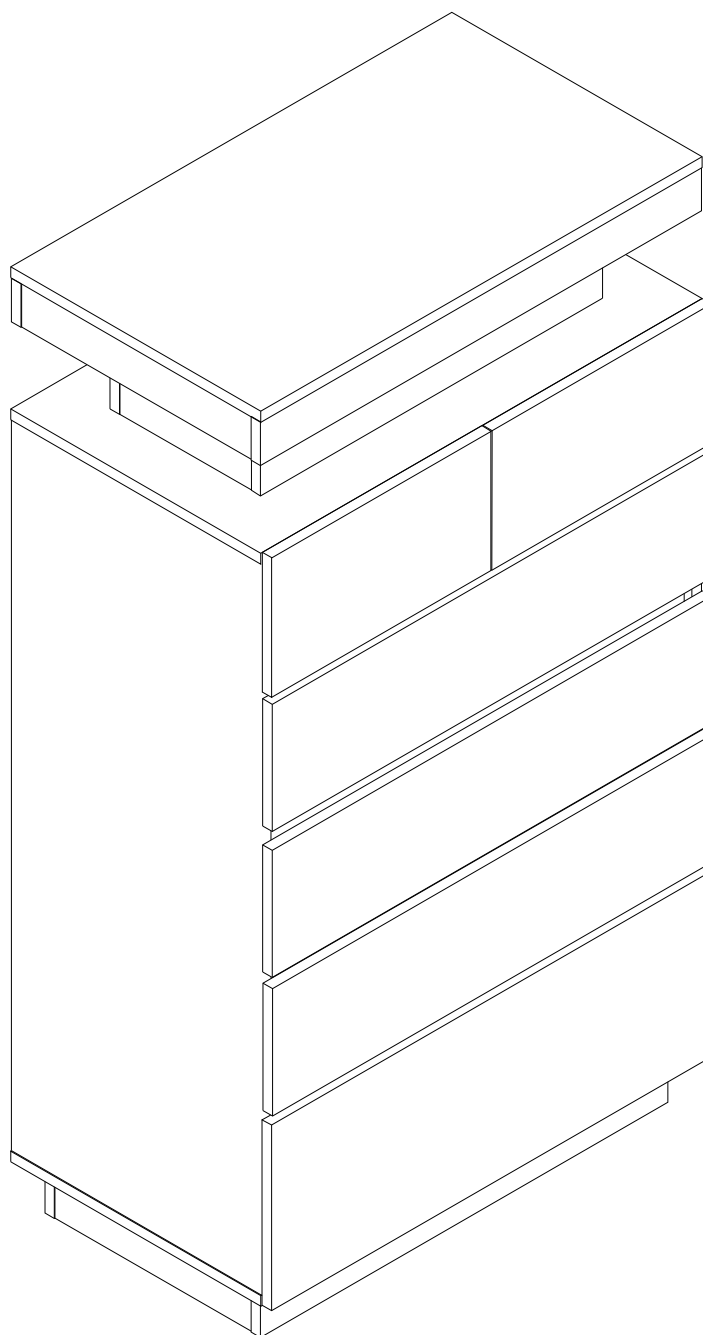

DG-PB-0009/DG-PB-0012

If you have any questions, please feel free to contact us.
Email: customerservice@seedayhome.com

NOTICE

Read through the instructions before installing the product. Suggested assembly for multiple people.

Give yourself enough room for the assembly process and follow the instructions to assemble the items correctly.

CAUTION If you use an electric screwdriver to tighten screws, be careful to slow down and stop when the screws are tightened. Failure to do so may result in stripping of the screws.

Before installation, sort all parts and check that the accessories are in good condition.

If the installation kit is equipped with anti-tip device, it is recommended to secure the cabinet to the wall with screws after installation to prevent it from falling down.

The remaining parts are spares that can be kept for future replacement if needed.

SAFETY INFORMATION

The accessory bag contains some small accessories , which should be kept away from children.

Kids are not allowed to climb or play with the product for safety reasons.

HINWEIS

Lesen Sie vor der Montage des Produkts die Anleitung durch. Empfohlene Montage für mehrere Personen.

Geben Sie sich genügend Platz für den Montageprozess und folgen Sie den Anweisungen, um die Artikel richtig zusammenzubauen.

VORSICHT Wenn Sie zum Anziehen von Schrauben einen elektrischen Schraubendreher verwenden, achten Sie darauf, dass Sie langsamer fahren und anhalten, wenn die Schrauben angezogen sind. Andernfalls kann es zum Abisolieren der Schrauben kommen.

Vor der Installation sortieren Sie alle Teile und überprüfen Sie, ob das Zubehör in gutem Zustand ist.

Wenn der Einbausatz mit einer Kippsicherung ausgestattet ist, wird empfohlen, den Schrank nach der Installation mit Schrauben an der Wand zu befestigen, damit er nicht herunterfallen kann.

Die restlichen Teile sind Ersatzteile, die bei Bedarf für künftigen Austausch aufbewahrt werden können.

SICHERHEITSINFORMATIONEN

Die Zubehörtasche enthält einige kleine Accessoires, die von Kindern ferngehalten werden sollten.

Kinder dürfen aus Sicherheitsgründen nicht klettern oder mit dem Produkt spielen.

AVVISO

Leggere attentamente le istruzioni prima di installare il prodotto. Montaggio consigliato per più persone.

Concediti spazio sufficiente per il processo di assemblaggio e segui le istruzioni per assemblare correttamente gli elementi.

ATTENZIONE Se si utilizza un cacciavite elettrico per serrare le viti, fare attenzione a rallentare e fermarsi quando le viti sono serrate. In caso contrario, le viti possono essere rimosse.

Prima dell'installazione, ordinare tutte le parti e verificare che gli accessori siano in buone condizioni.

Se il kit di installazione è dotato di dispositivo antiribaltamento, si raccomanda di fissare il mobile alla parete con delle viti dopo l'installazione per evitare che cada.

Le restanti parti sono pezzi di ricambio che possono essere conservati per la sostituzione futura, se necessario.

INFORMAZIONI SULLA SICUREZZA

La borsa accessorio contiene alcuni piccoli accessori, che dovrebbero essere tenuti lontano dai bambini.

I bambini non possono arrampicarsi o giocare con il prodotto per motivi di sicurezza.

Notifications

Lisez les instructions avant d'installer le produit. Assemblage suggéré pour plusieurs personnes.

Donnez - vous suffisamment d'espace pour l'assemblage et suivez les instructions pour assembler correctement les articles.

Attention si vous utilisez un tournevis électrique pour serrer les vis, faites attention à ralentir et à vous arrêter lorsque vous serrez les vis. Sinon, il peut provoquer la chute des vis.

Avant l'installation, toutes les pièces sont triées et les accessoires sont vérifiés en bon état.

Si le kit de montage est équipé d'un dispositif anti-basculement, il est recommandé de fixer l'armoire au mur avec des vis après l'installation pour éviter qu'elle ne tombe.

Les pièces restantes sont des pièces de rechange qui peuvent être conservées pour un remplacement futur si nécessaire.

Informations de sécurité

Accessoires le sac contient de petits accessoires qui doivent être tenus à l'écart des enfants.

Pour des raisons de sécurité, les enfants ne doivent pas grimper ou jouer avec le produit.

Aviso

Lea atentamente las instrucciones antes de instalar el producto. Montaje sugerido para varias personas.

Deje suficiente espacio para ensamblar y siga las instrucciones para ensamblar correctamente los artículos.

Cuidado si aprieta el tornillo con un destornillador eléctrico, preste atención a reducir la velocidad y detenerse al apretar el tornillo. De lo contrario, puede causar que los tornillos se caigan.

Antes de la instalación, clasifique todas las piezas y verifique si los accesorios están intactos.

Si el kit de instalación está equipado con un dispositivo antivuelco, se recomienda fijar el armario a la pared con tornillos después de la instalación para evitar que se caiga.



El resto de las piezas son piezas de repuesto y, si es necesario, se pueden conservar para su reemplazo futuro.

Información de Seguridad



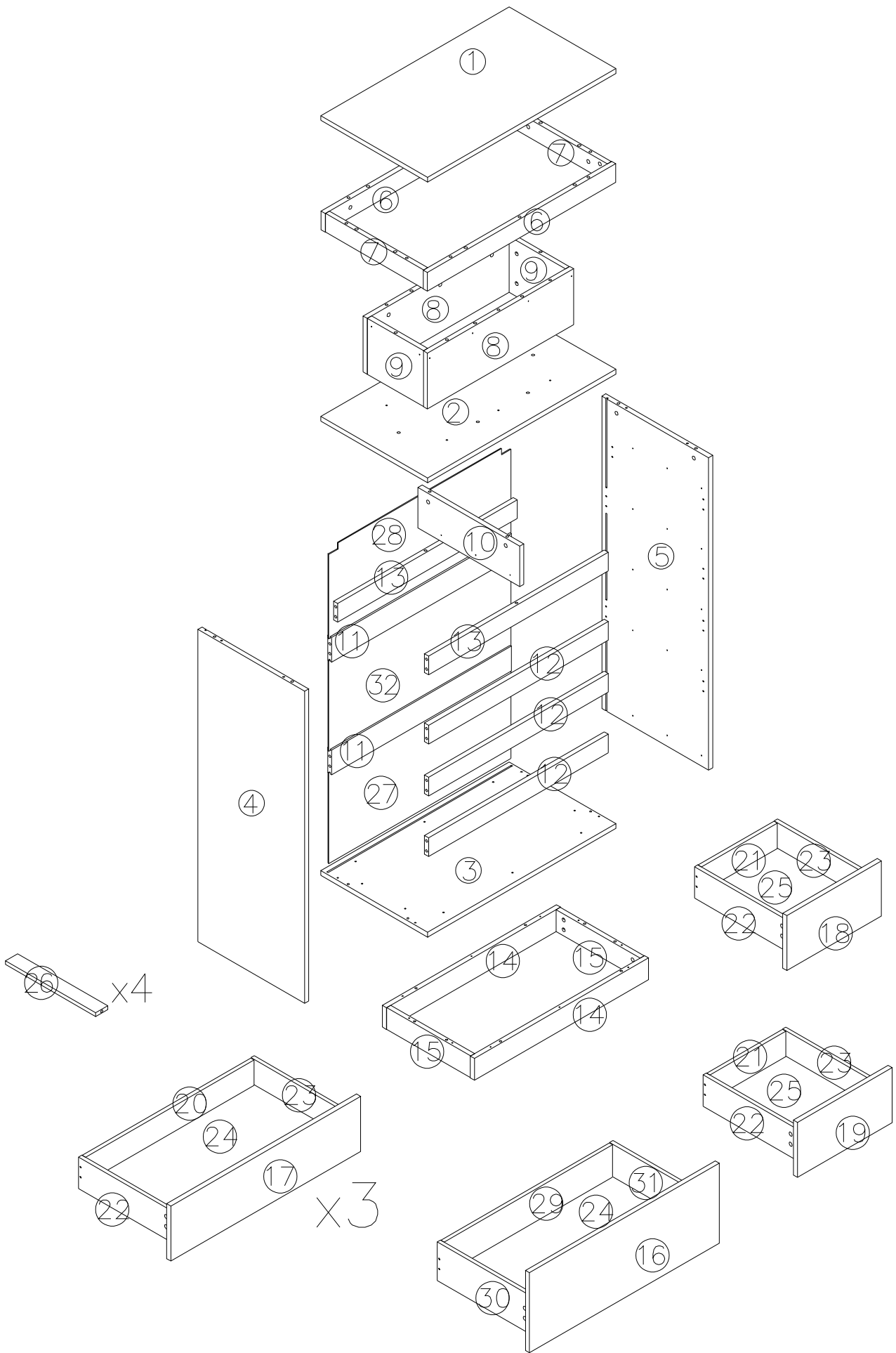

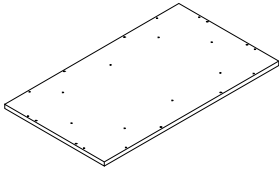
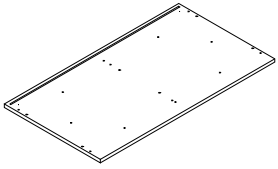
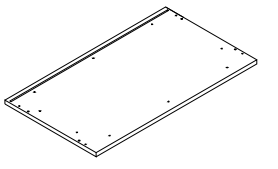
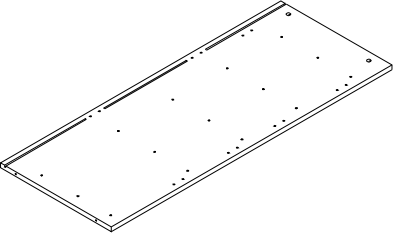
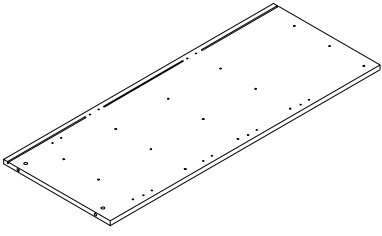
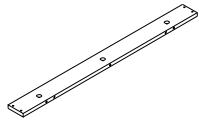
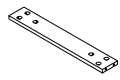
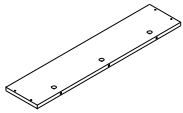

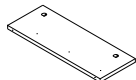
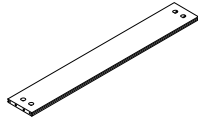
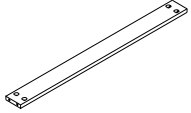
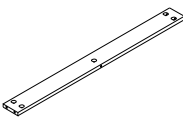
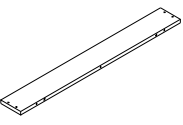
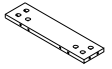
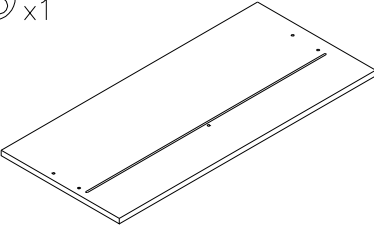
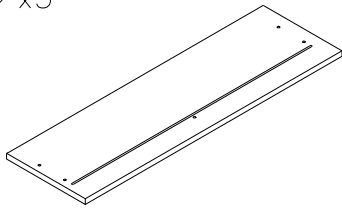
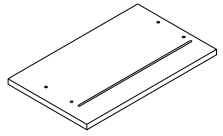

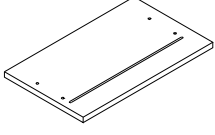
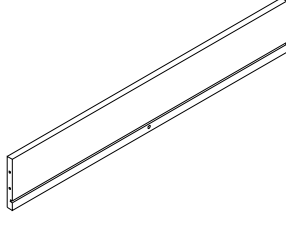
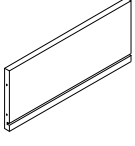
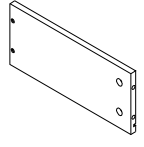
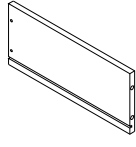
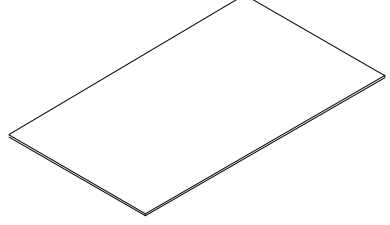
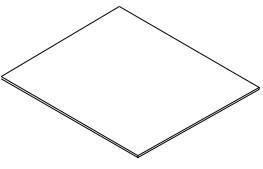
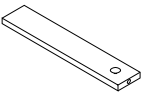
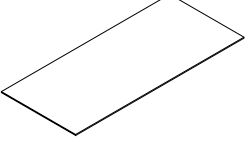
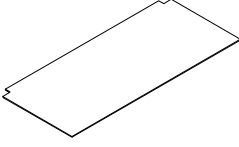
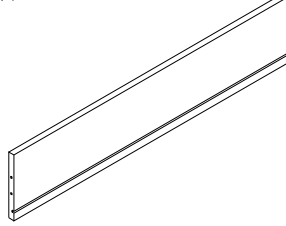
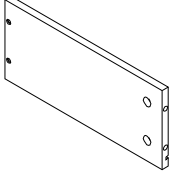
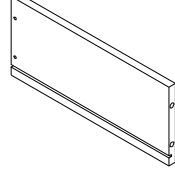
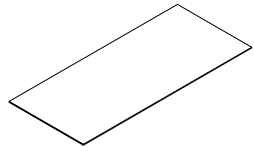
Hay algunos pequeños accesorios en el paquete de accesorios que deben mantenerse alejados de los niños.

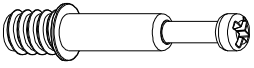
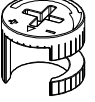
Por razones de seguridad, los niños no pueden escalar ni jugar con el producto.

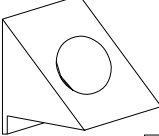

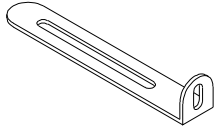
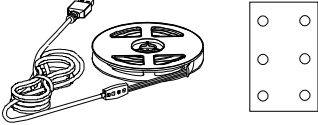
<p>① x1</p> 	<p>② x1</p> 	<p>③ x1</p> 
<p>④ x1</p> 	<p>⑤ x1</p> 	<p>⑥ x2</p> 
<p>⑦ x2</p> 	<p>⑧ x2</p> 	<p>⑨ x2</p> 
<p>⑩ x1</p> 	<p>⑪ x2</p> 	<p>⑫ x3</p> 
<p>⑬ x2</p> 	<p>⑭ x2</p> 	<p>⑮ x2</p> 
<p>⑯ x1</p> 	<p>⑰ x3</p> 	<p>⑱ x1</p> 

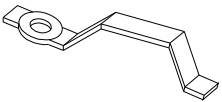
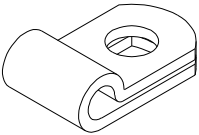
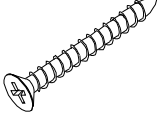
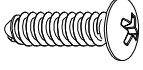
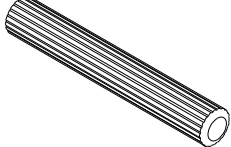
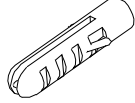
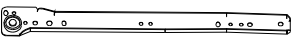
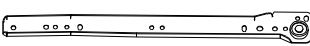
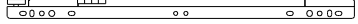
<p>①⑨ x1</p> 	<p>②⑩ x3</p> 	<p>②① x2</p> 
<p>②② x5</p> 	<p>②③ x5</p> 	<p>②④ x4</p> 
<p>②⑤ x2</p> 	<p>②⑥ x4</p> 	<p>②⑦ x1</p> 
<p>②⑧ x1</p> 	<p>②⑨ x1</p> 	<p>③⑩ x1</p> 
<p>③① x1</p> 	<p>③② x1</p> 	

<p>A</p>  <p>M6x35mm</p> <p>108+5pcs</p>	<p>B</p>  <p>Ø15x10mm</p> <p>108+5pcs</p>	<p>C</p>  <p>M3.5x30mm</p> <p>28+3pcs</p>
<p>D</p>  <p>M3x12mm</p> <p>83+4pcs</p>	<p>E</p>  <p>12+2pcs</p>	<p>F</p>  <p>M7x38mm</p> <p>18+2pcs</p>
<p>G</p>  <p>2pcs</p>	<p>H</p>  <p>1pcs</p>	<p>I</p>  <p>M3.5x14mm</p> <p>12+2pcs</p>
<p>J</p>  <p>11+2pcs</p>	<p>K</p>  <p>1pcs</p>	<p>L</p>  <p>M4x40mm</p> <p>2pcs</p>
<p>M</p>  <p>M4x12mm</p> <p>2pcs</p>	<p>N</p>  <p>M6x30mm</p> <p>18+3pcs</p>	<p>O</p>  <p>M4x40mm</p> <p>2pcs</p>
<p>CL</p>  <p>L300mm</p> <p>6 pcs</p>	<p>CR</p>  <p>L300mm</p> <p>6 pcs</p>	<p>DL</p>  <p>L300mm</p> <p>6 pcs</p>
<p>DR</p>  <p>L300mm</p> <p>6 pcs</p>		

STEP1

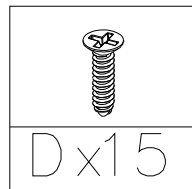
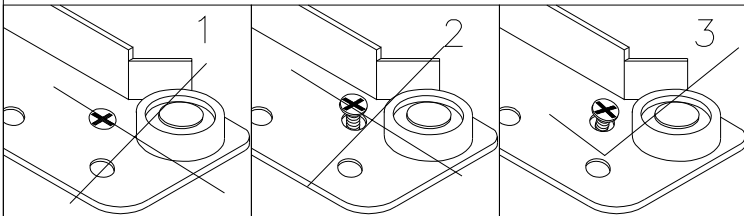
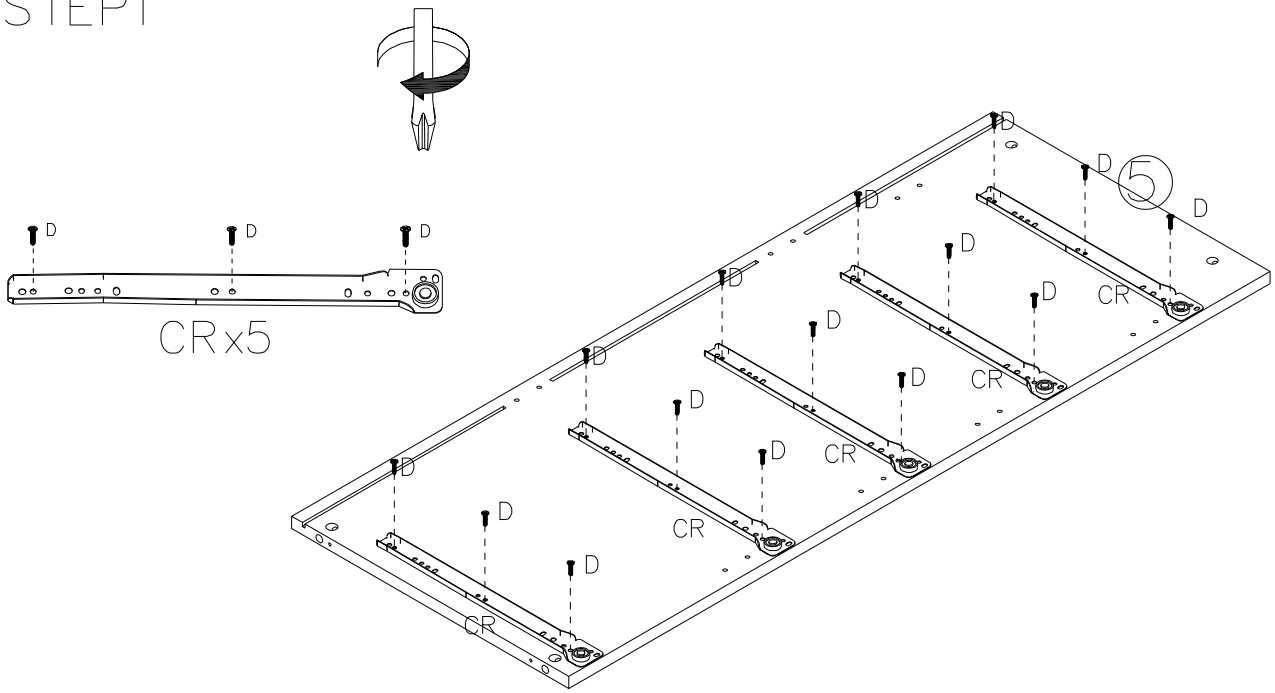

STEP2

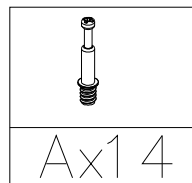
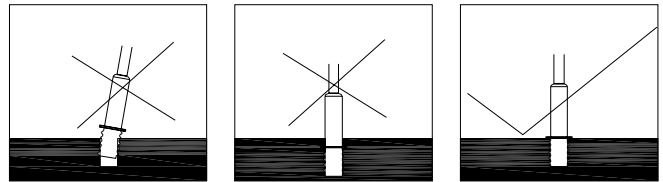
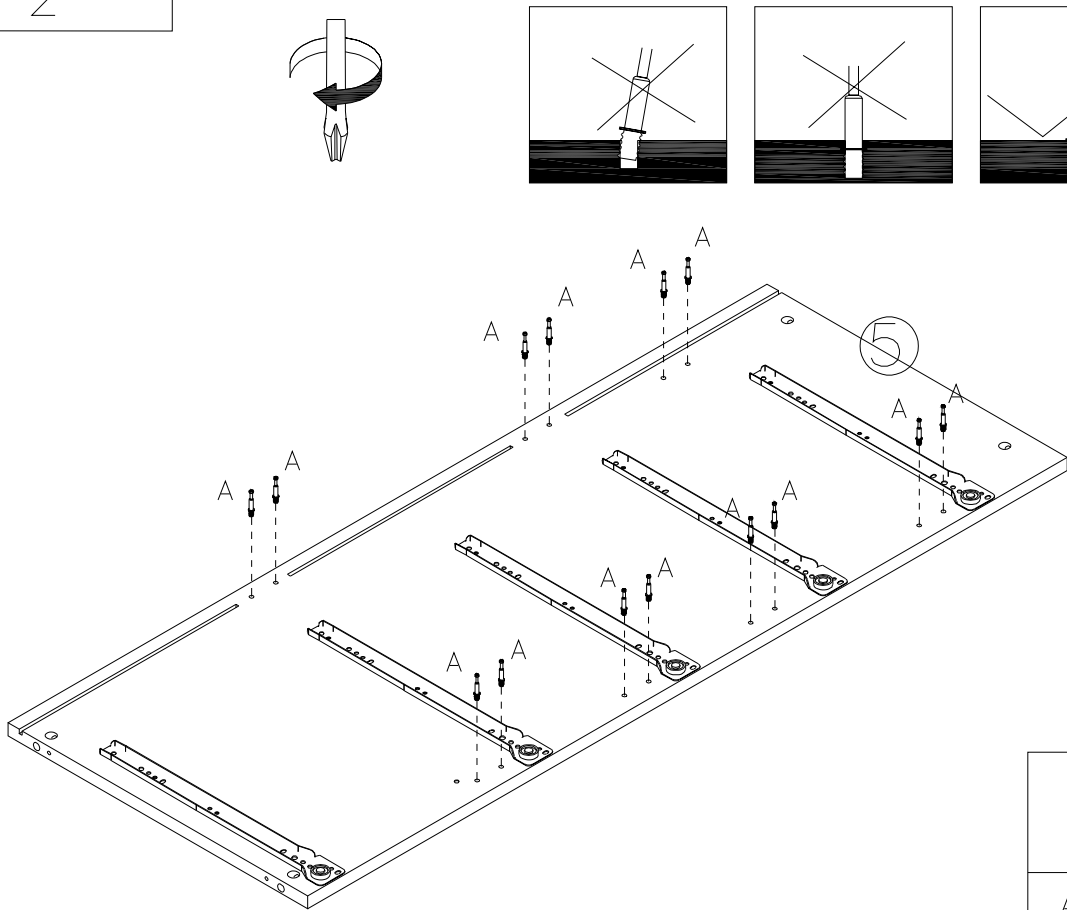

STEP 3

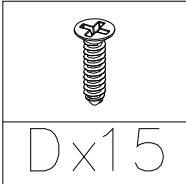
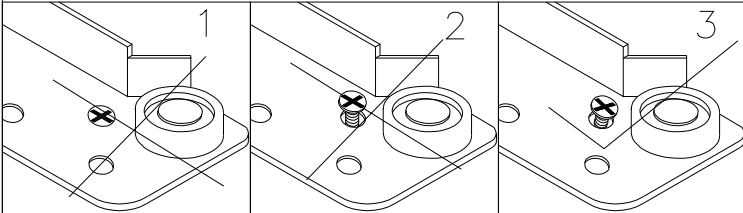
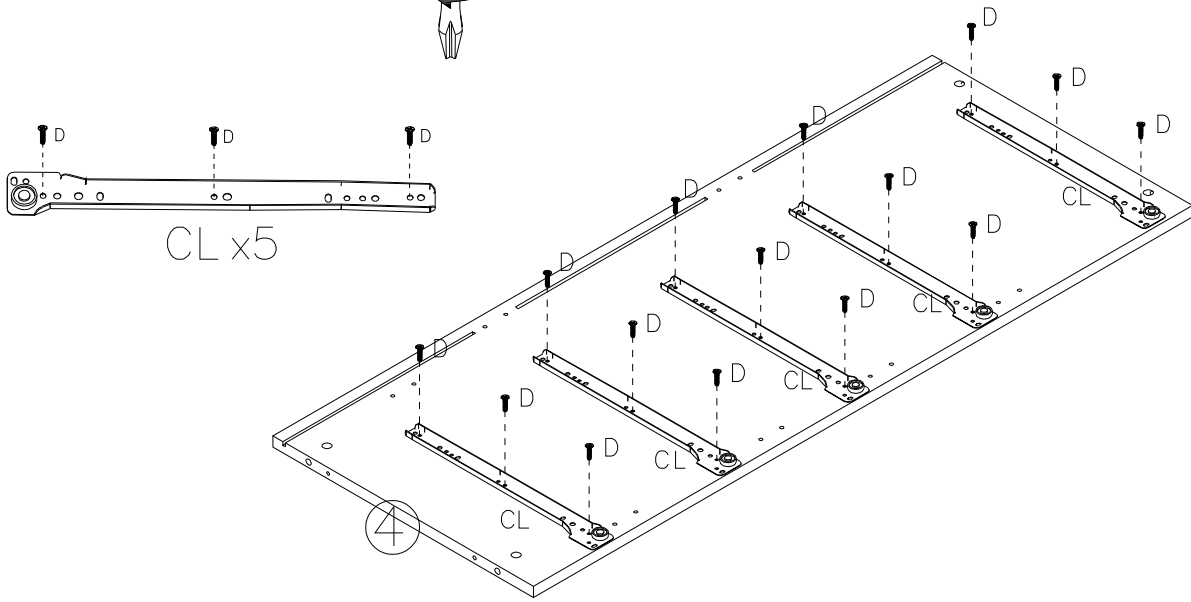
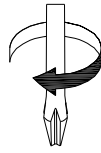

STEP 4

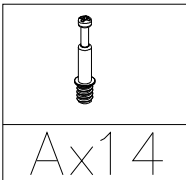
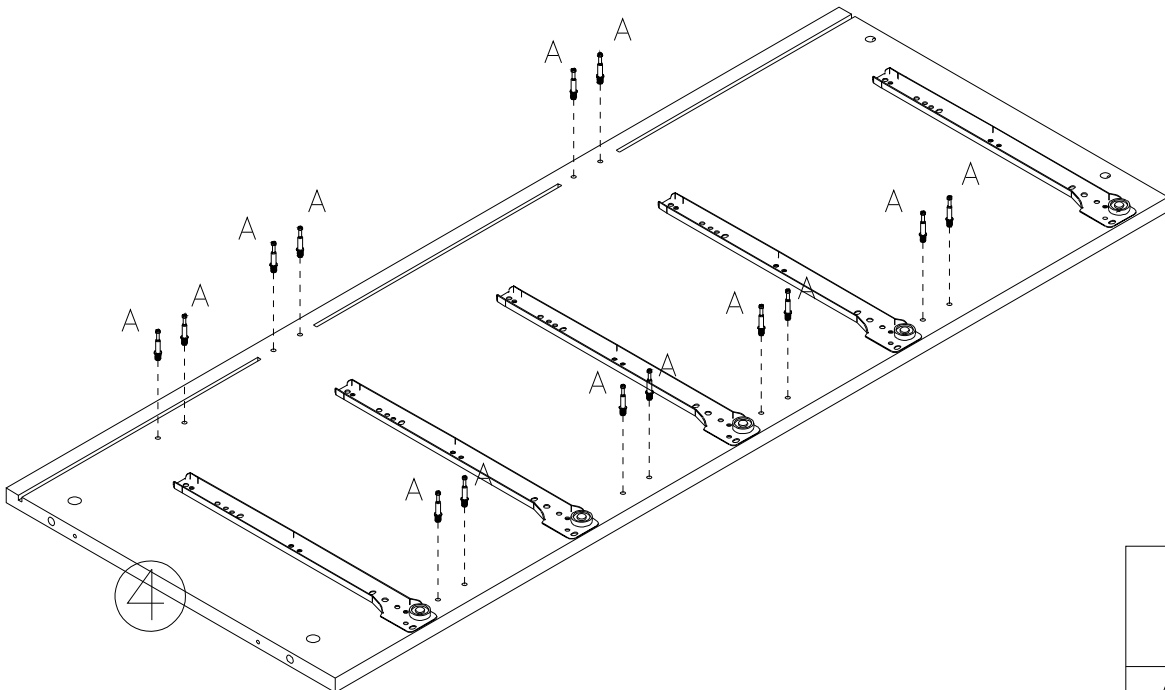
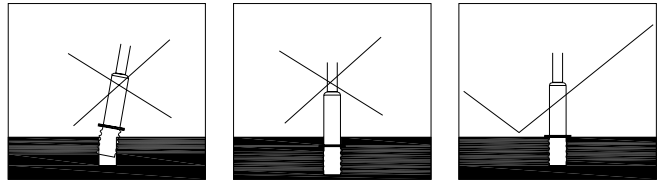
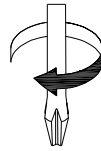

STEP5

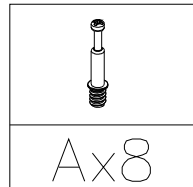
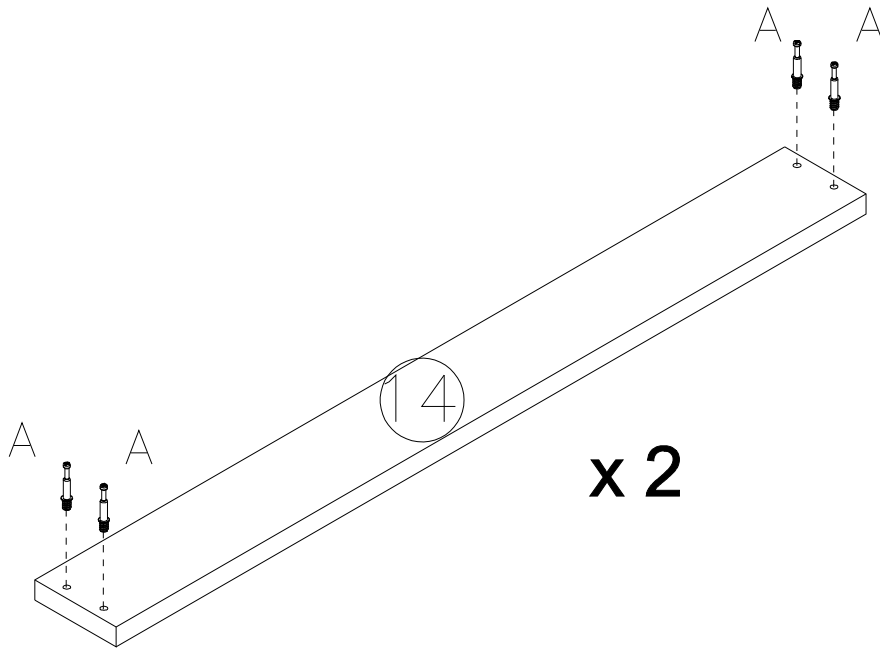
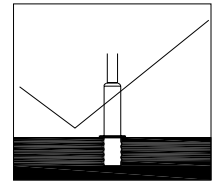
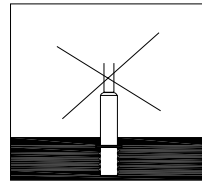
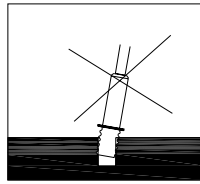
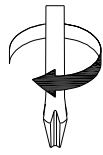

Ax8

STEP6

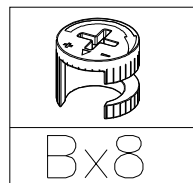
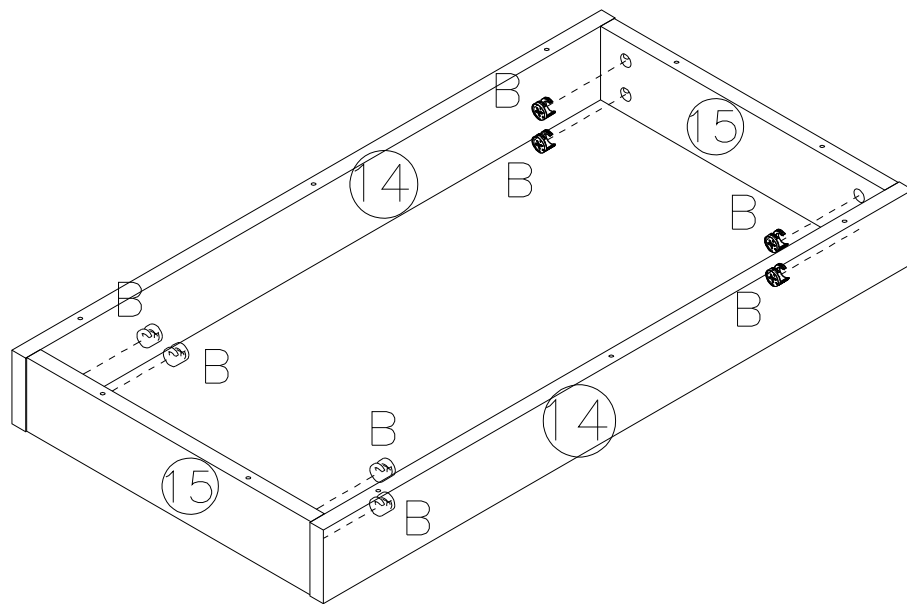
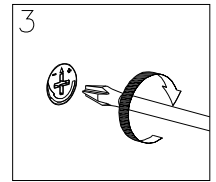
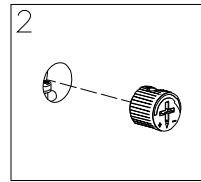
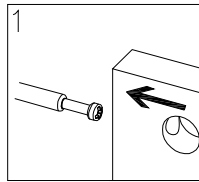
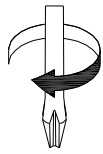

Bx8

STEP 7

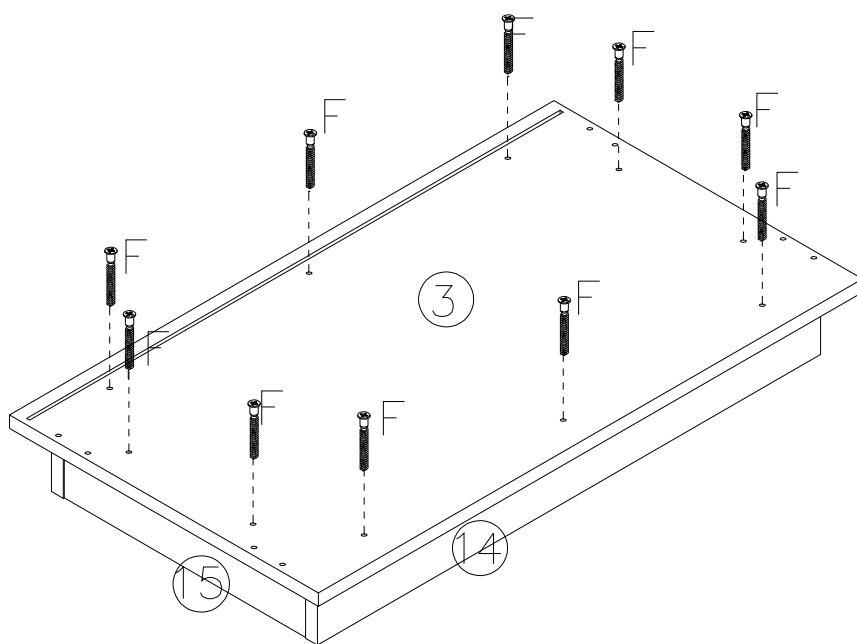

F x 10

STEP 8

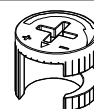
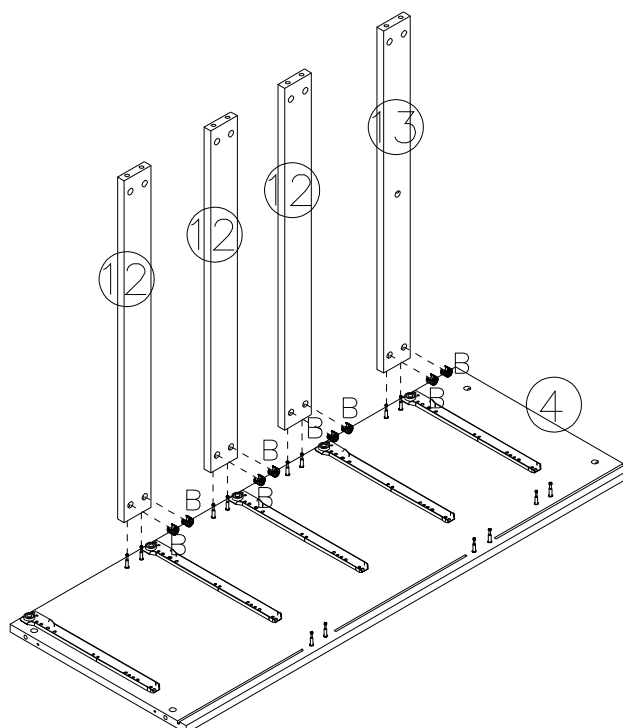
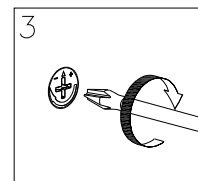
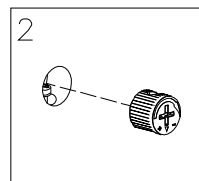
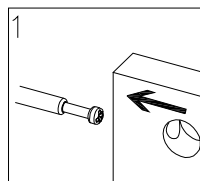
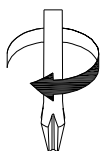

B x 8

STEP 9

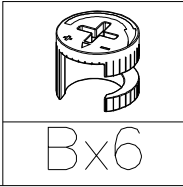
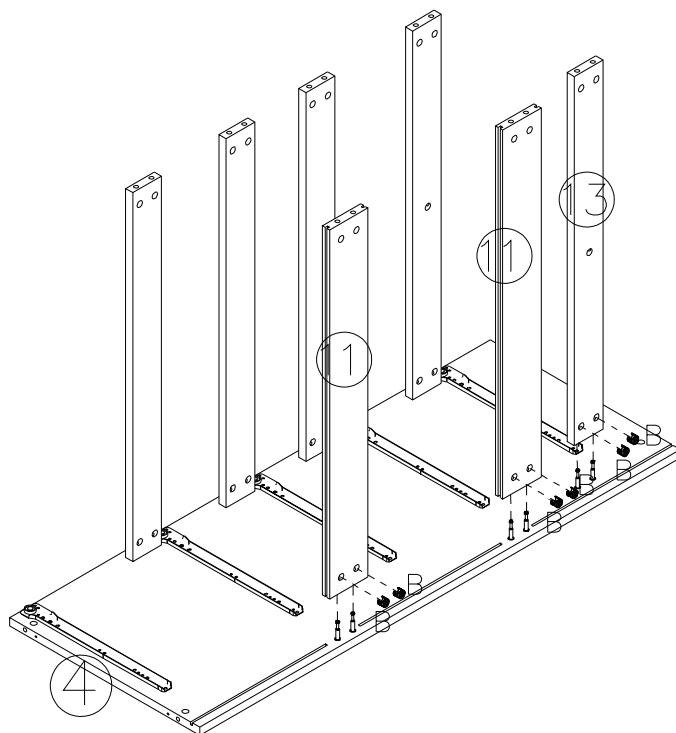
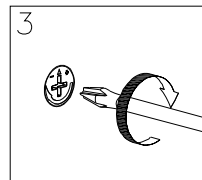
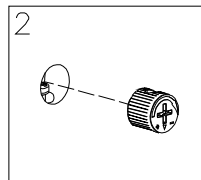
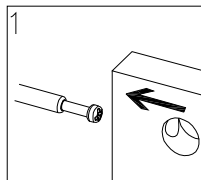
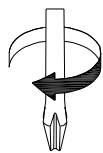

STEP 10

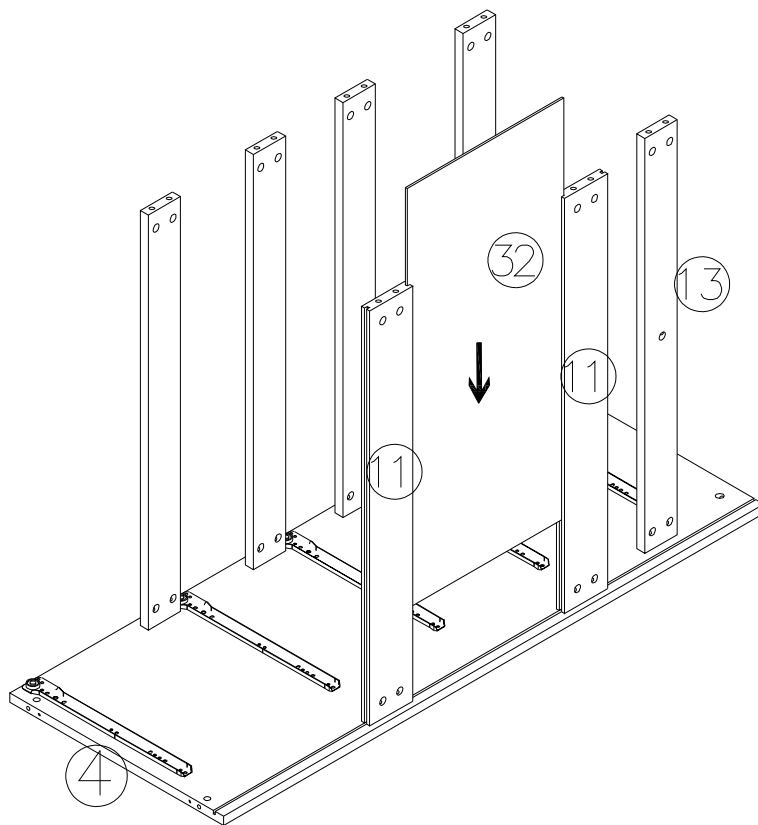

STEP11

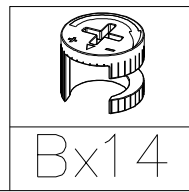
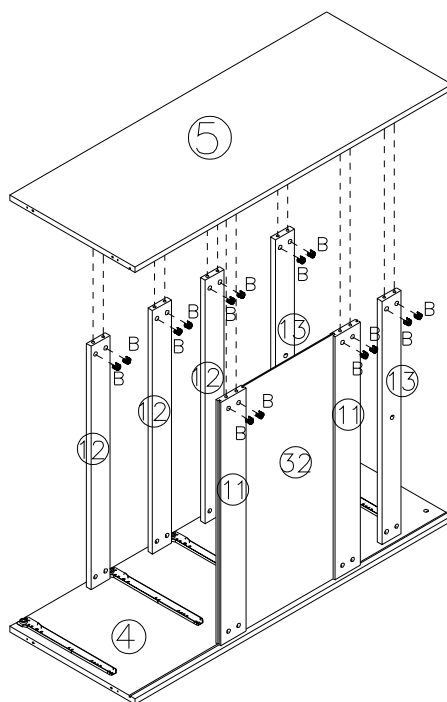
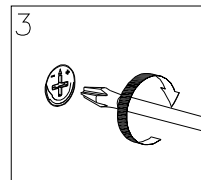
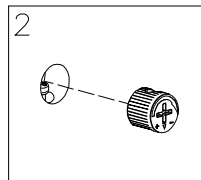
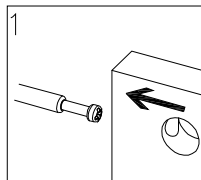

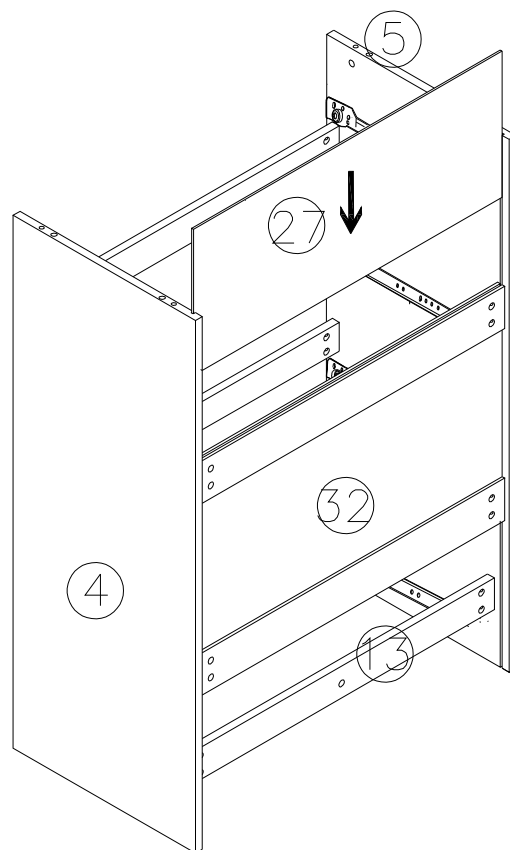

STEP12



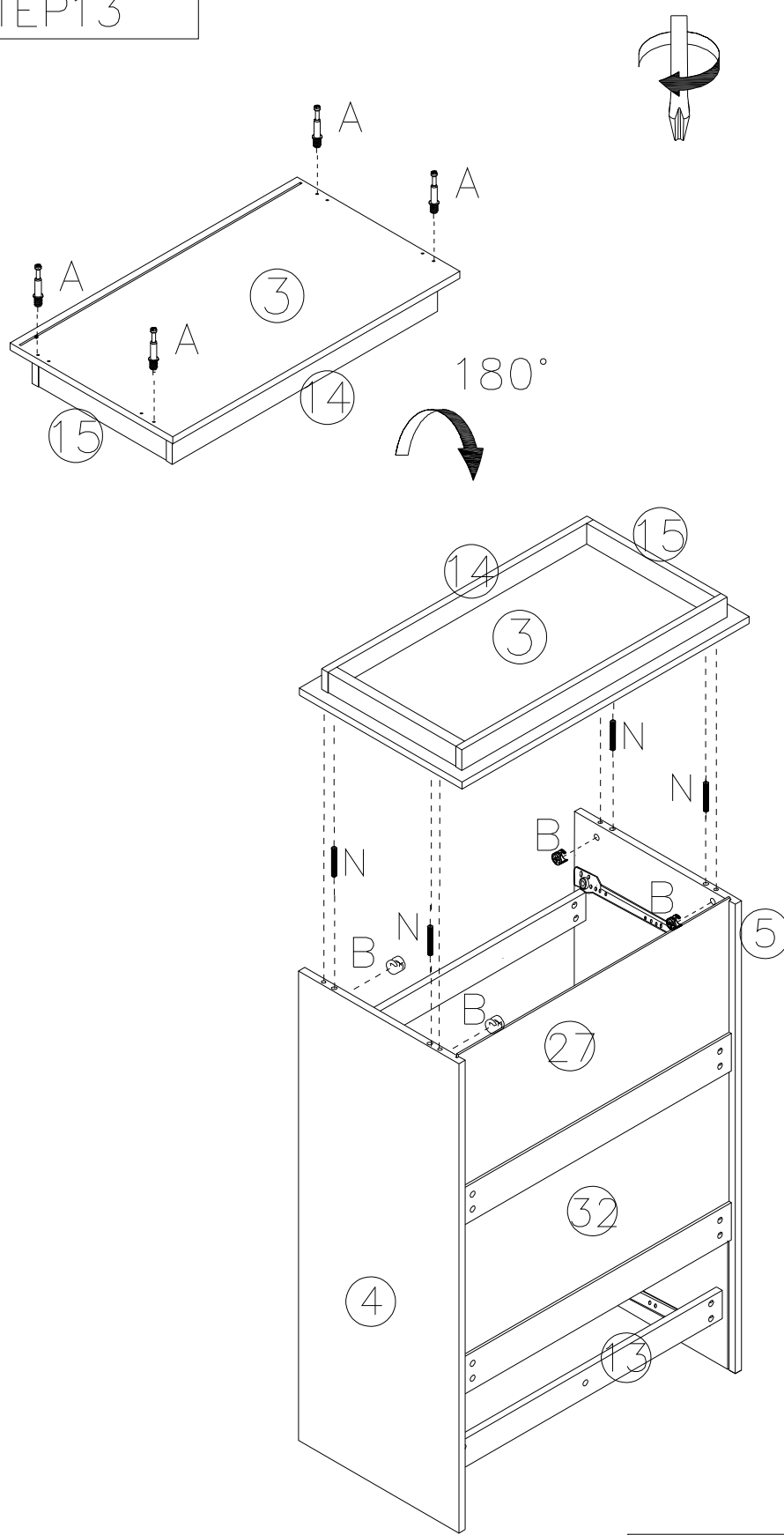

STEP13

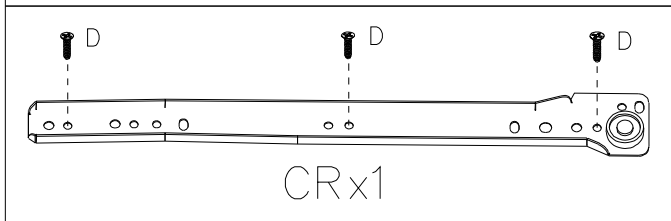
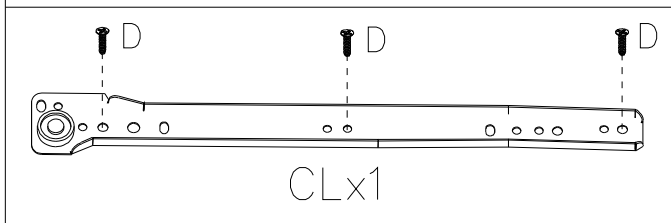
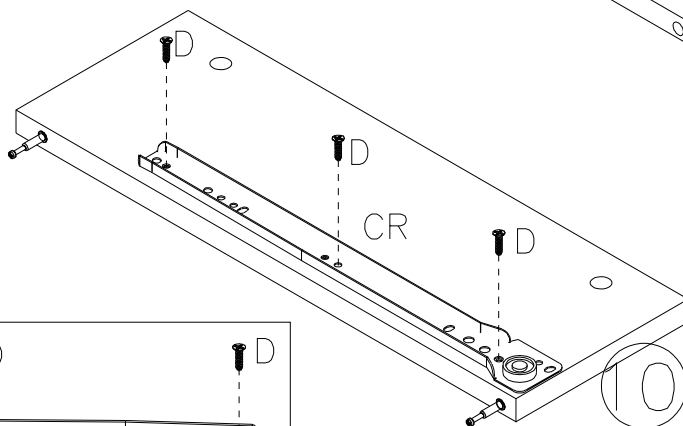
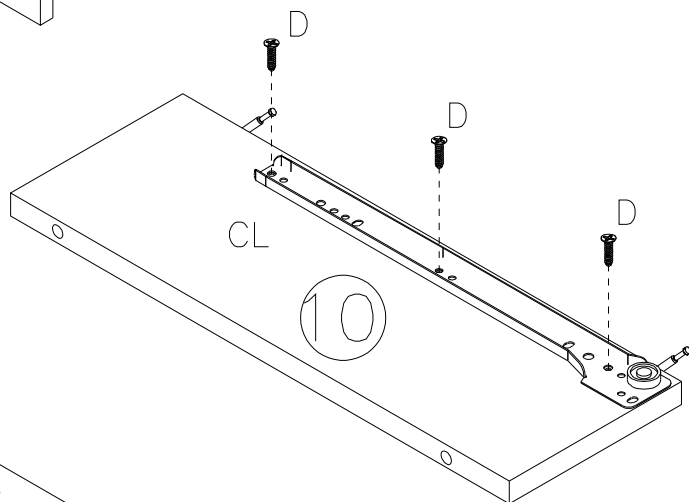
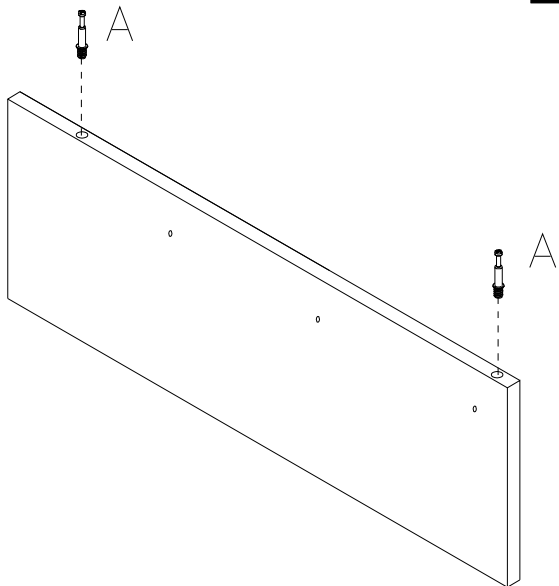
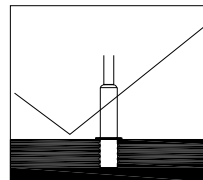
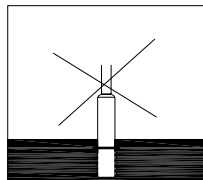
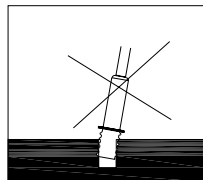

		
A x 4	B x 4	N x 4

STEP14



	
Ax2	Dx6

STEP15

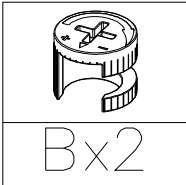
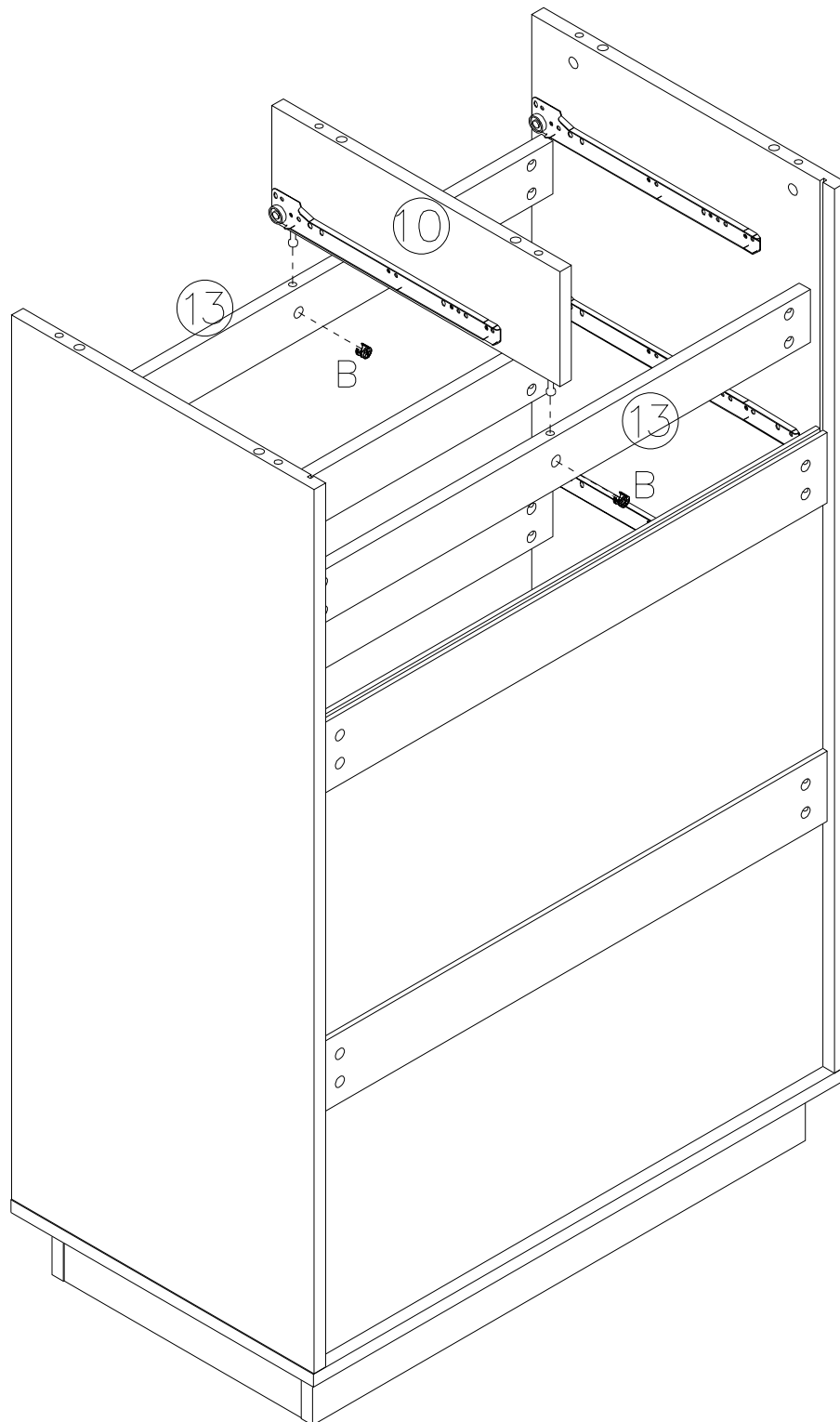
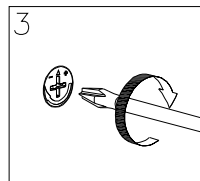
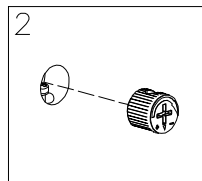
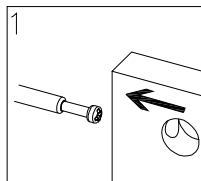
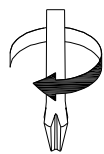

Bx2

STEP16

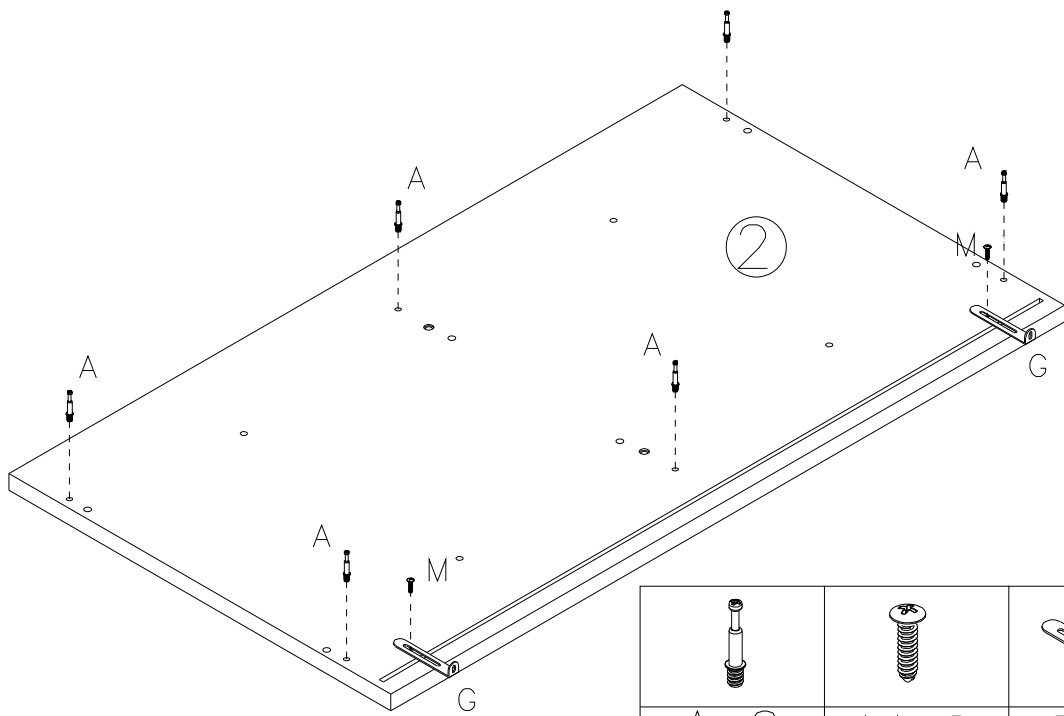
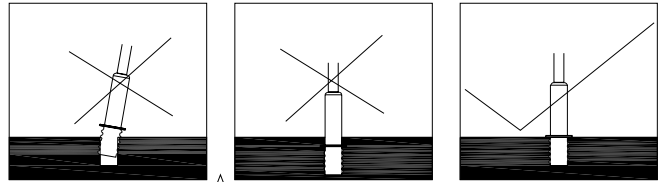
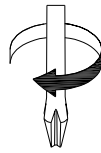

Ax6	Mx2	Gx2

STEP17

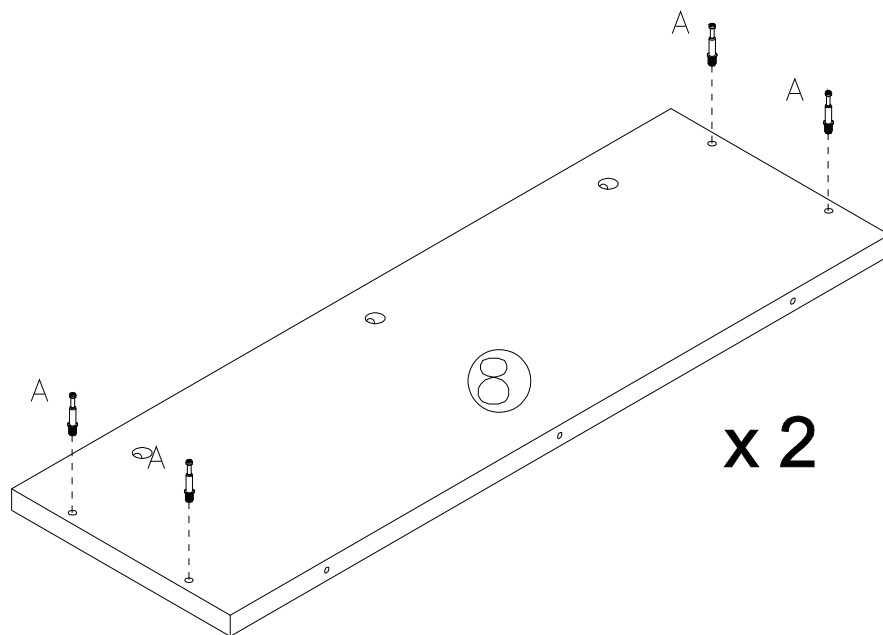
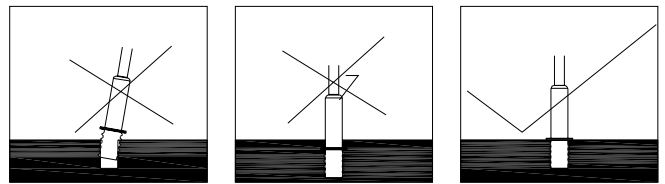
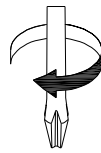

x 2

Ax8

STEP18

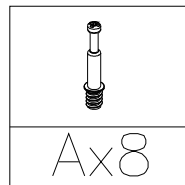
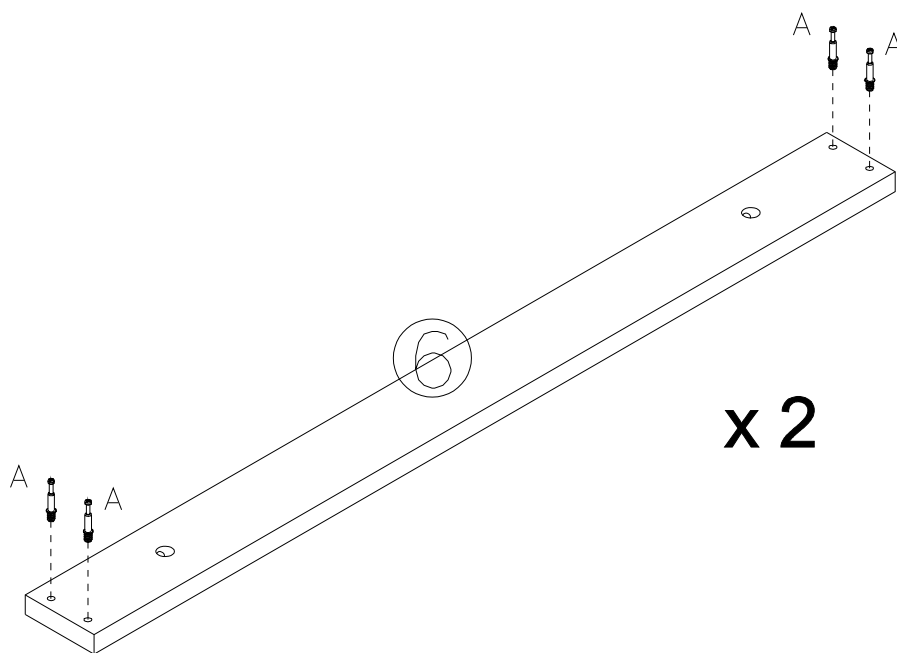
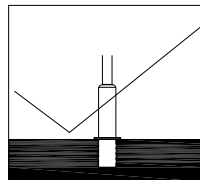
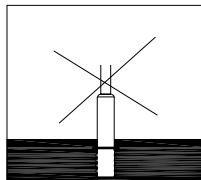
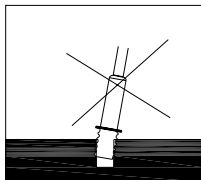

STEP 19

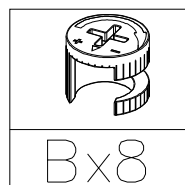
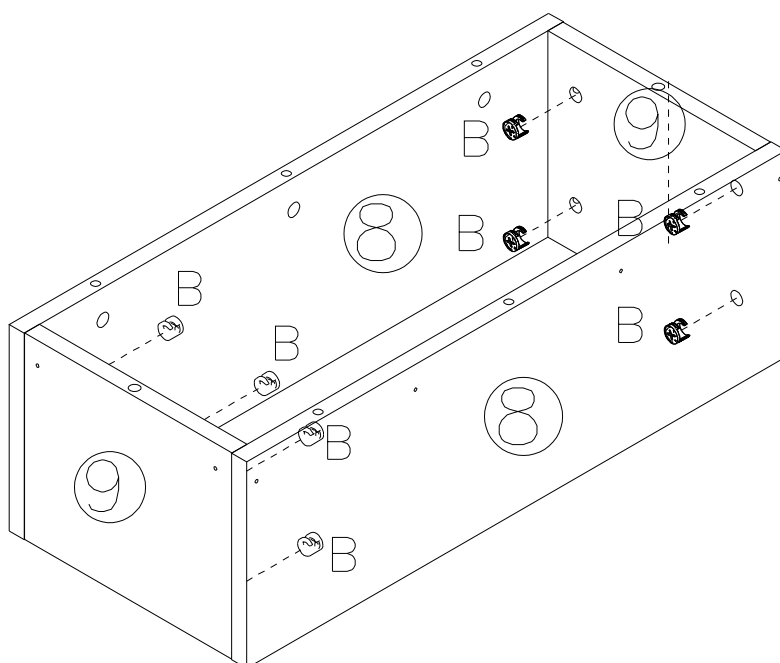
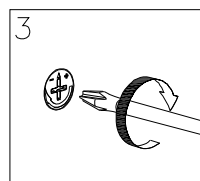
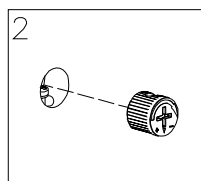
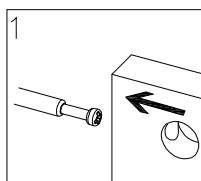

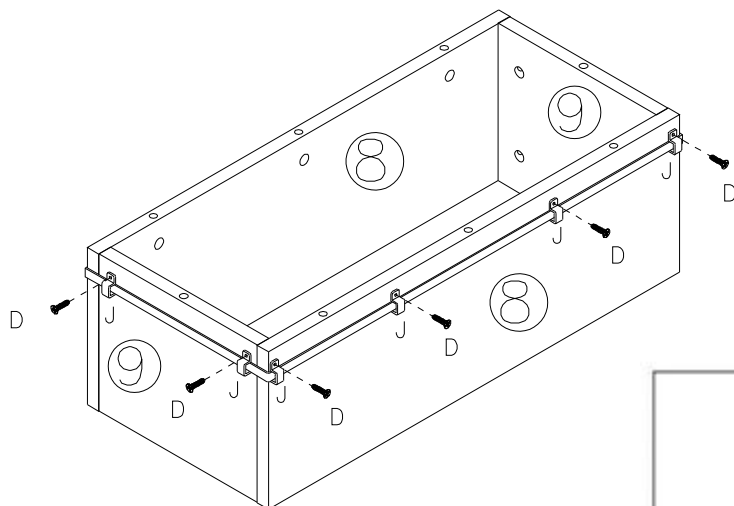
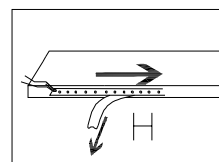
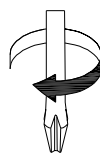

STEP 20

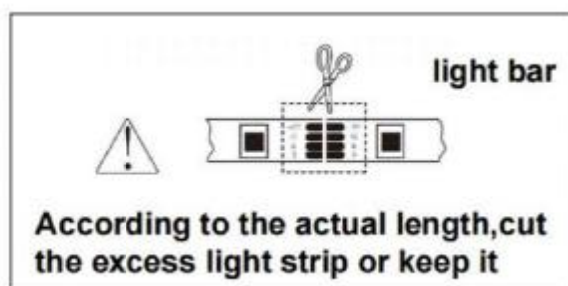
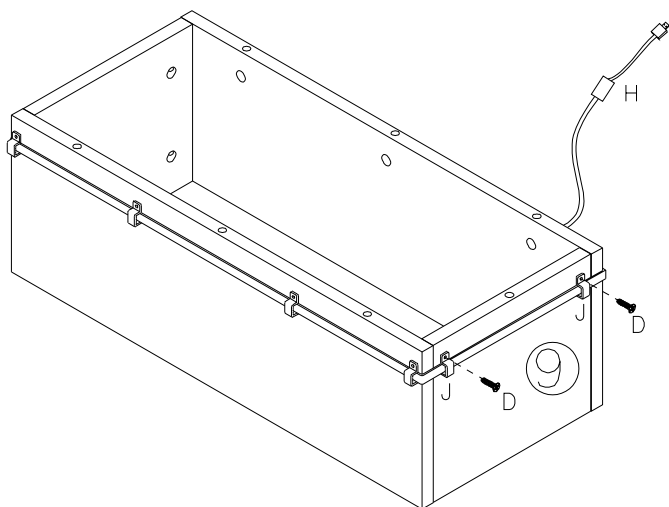

90°

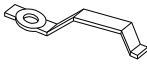

1. Connect LED color strip and controller, power on controller.
2. Scan two-dimensional code download APP.
3. Start APP, search and connect controller.
4. Enjoy the Bluetooth wireless control experience.

		
D x 8	J x 8	H x 1

STEP 21

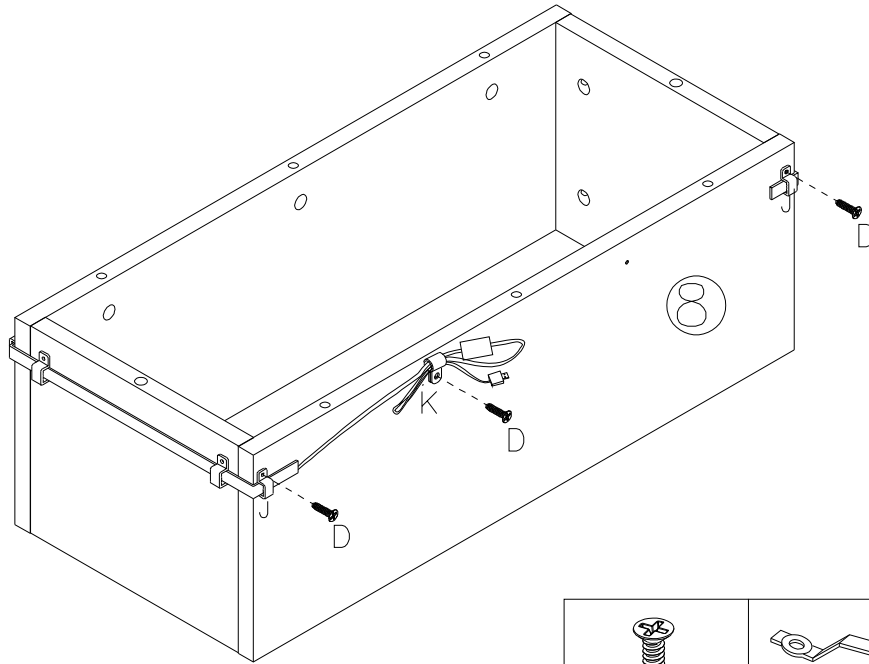
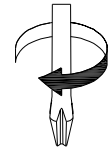

D x 3	J x 3	K x 1

STEP 22

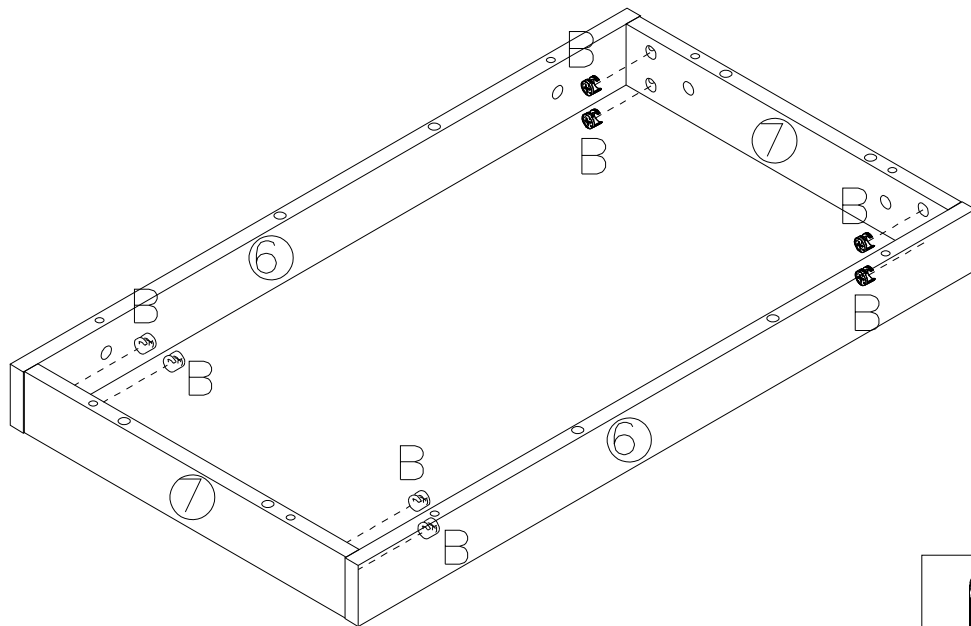
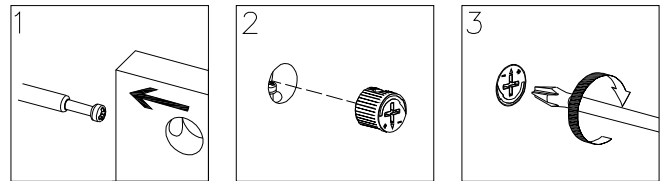

B x 8

STEP23

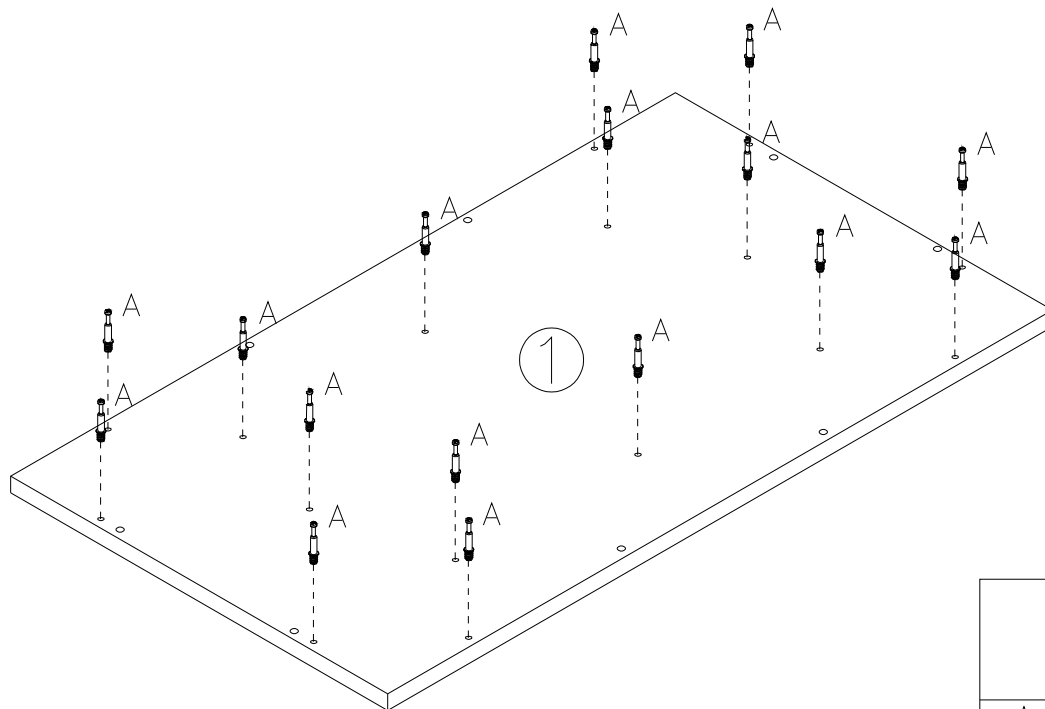
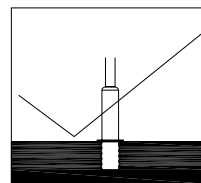
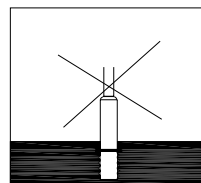
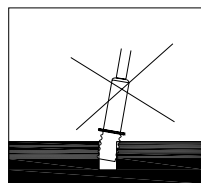
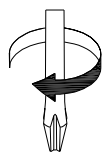

Ax16

STEP24

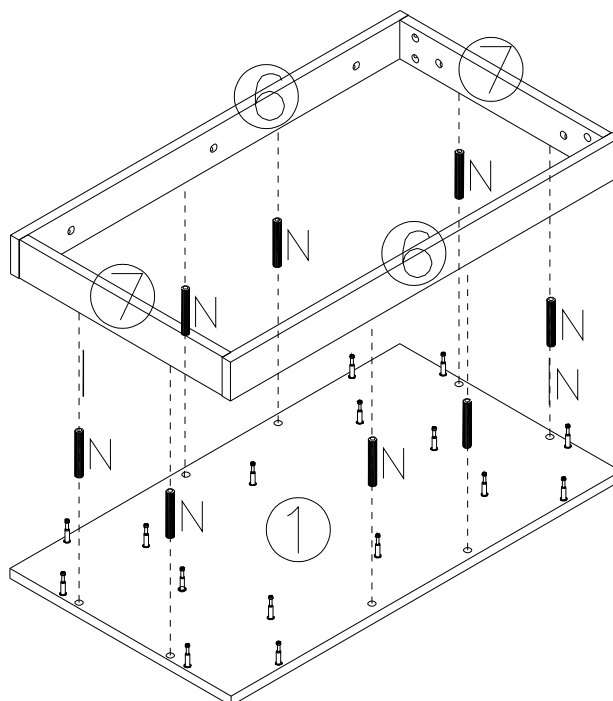

Nx8

STEP 25

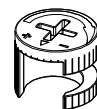
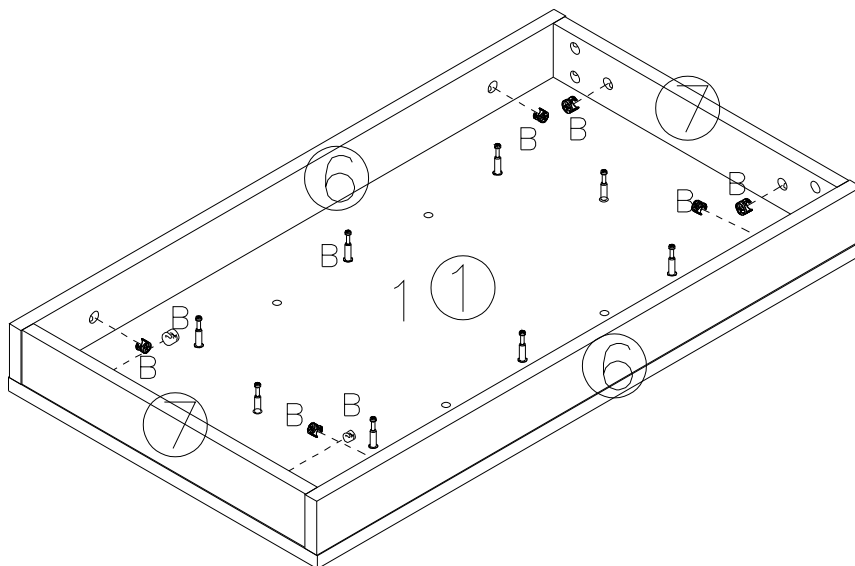
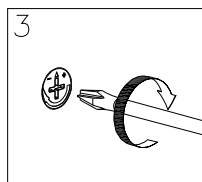
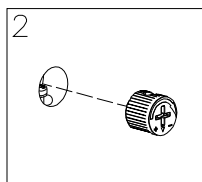
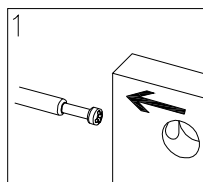
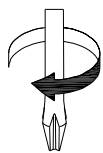

B x 8

STEP 26

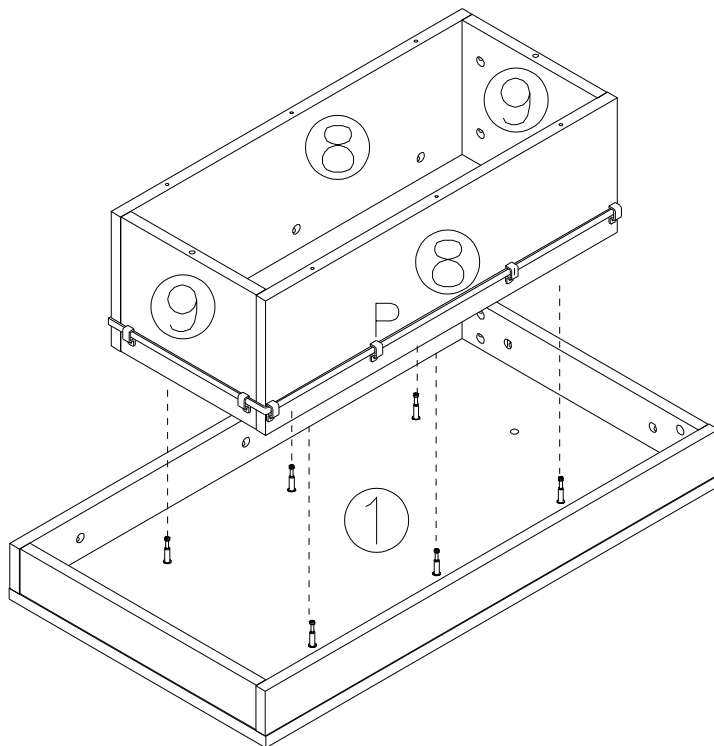

STEP 27

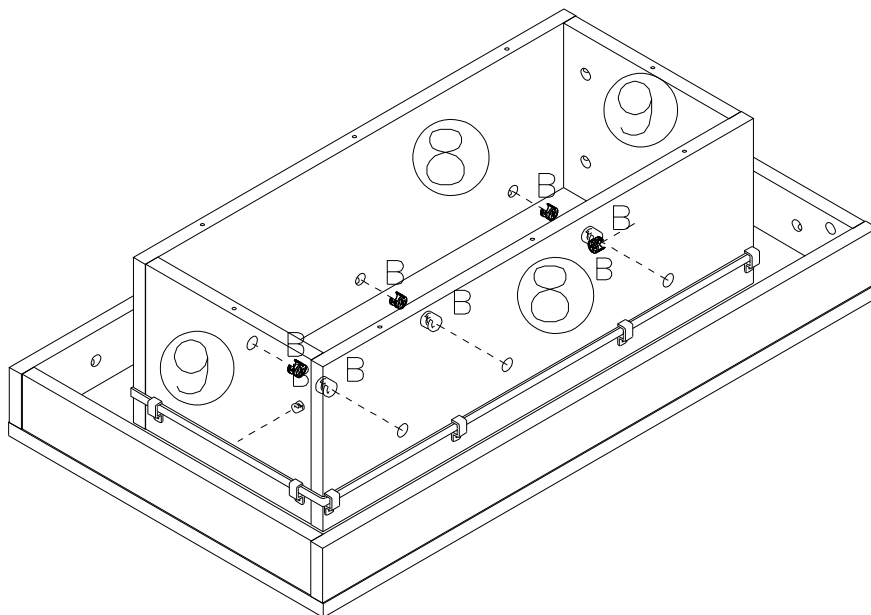
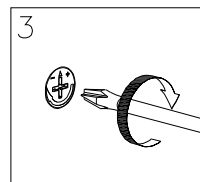
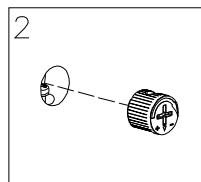
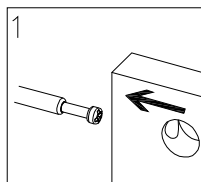
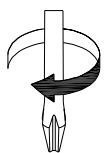

B x 8

STEP 28

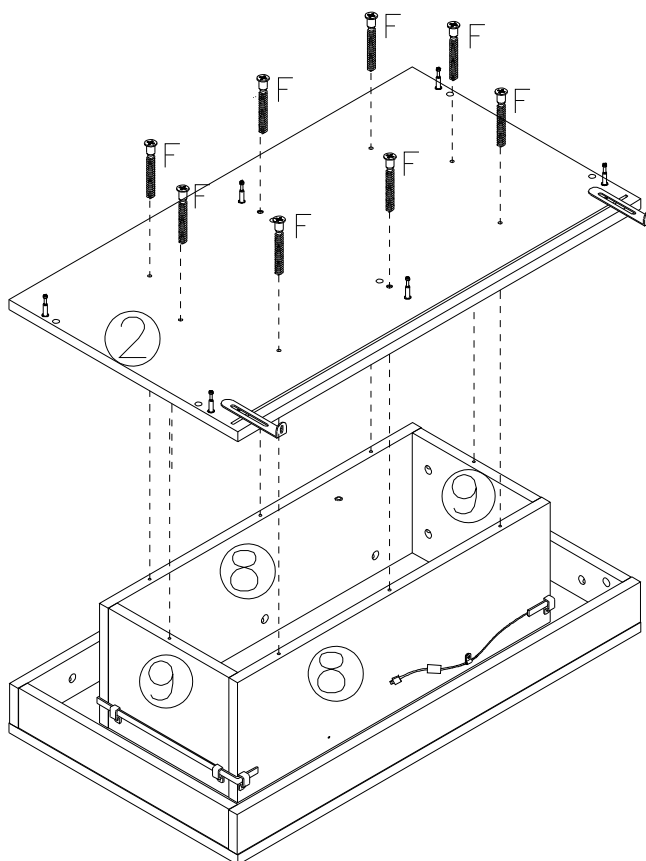
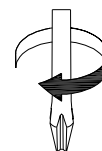

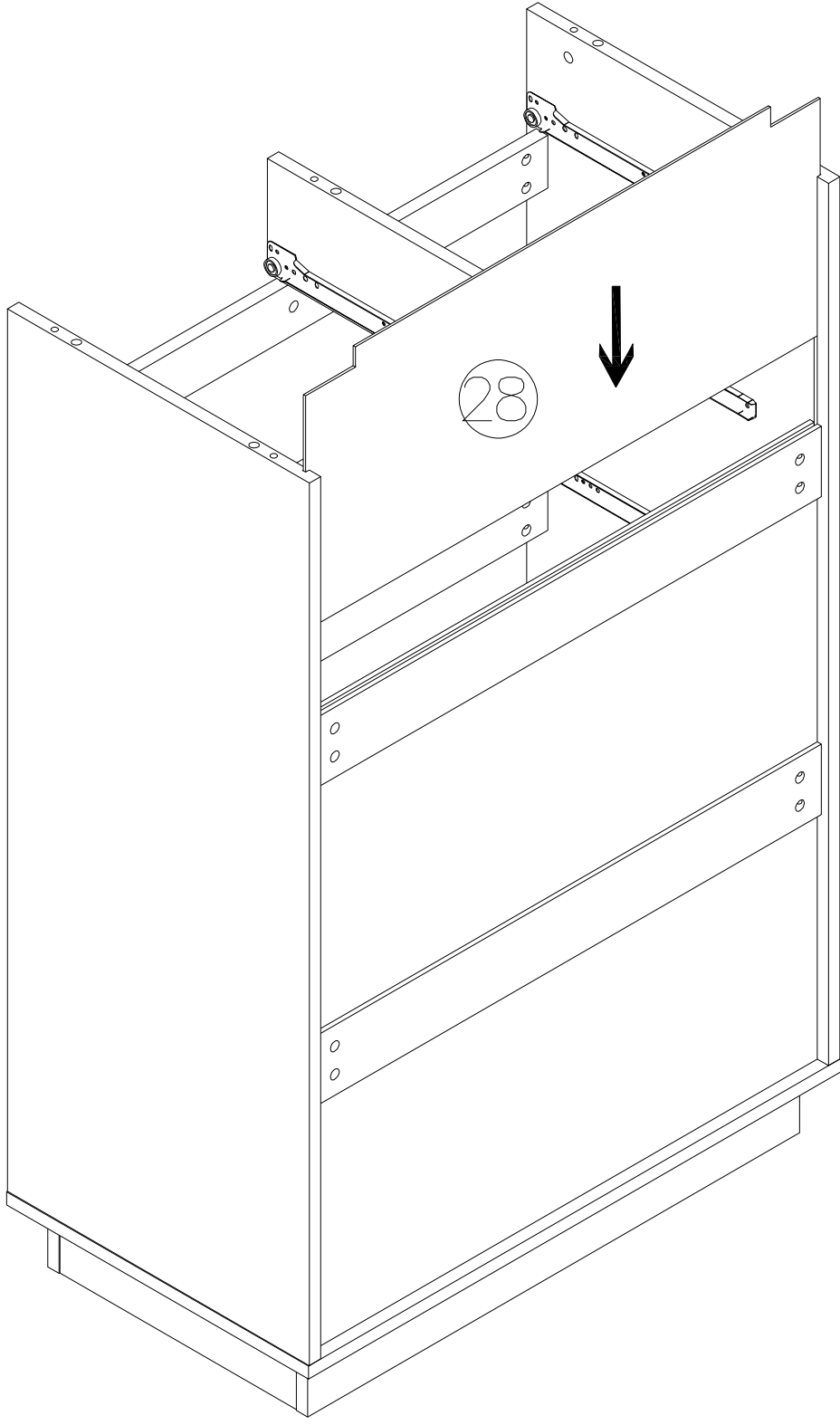

F x 8

STEP 29

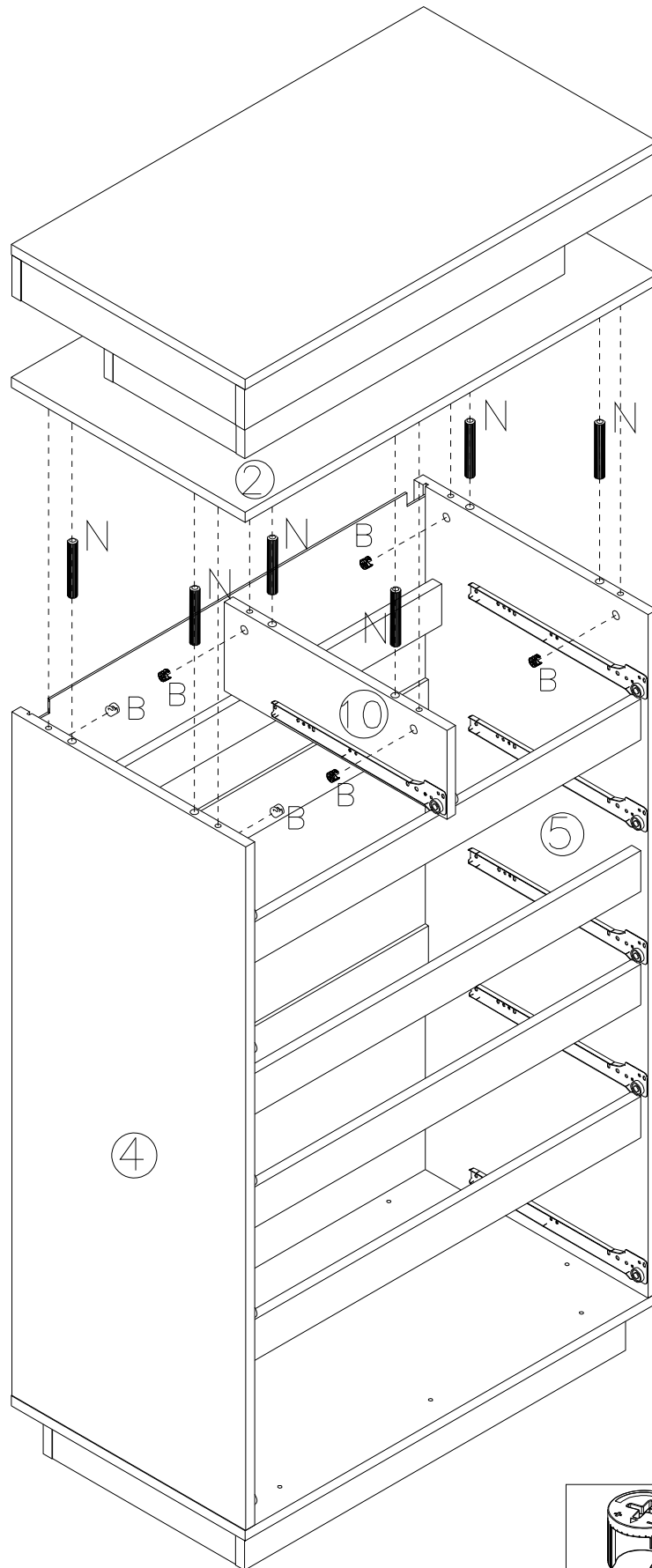

STEP 30



	
Bx6	Nx6

STEP 31

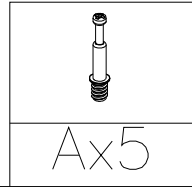
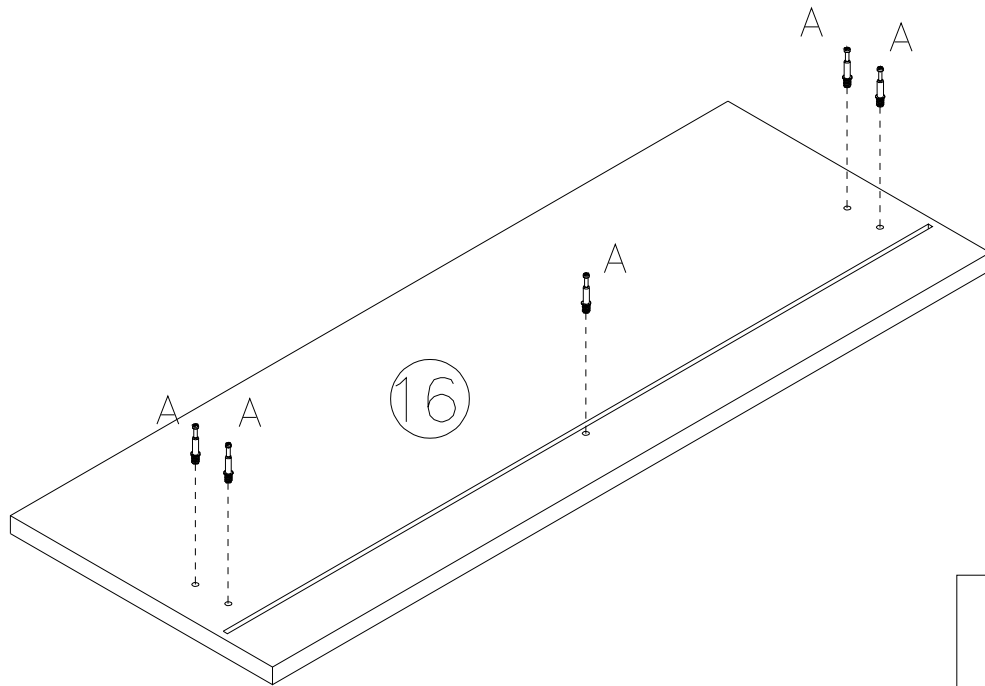
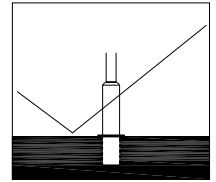
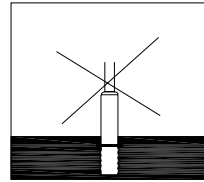
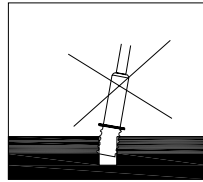
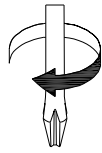

STEP 32

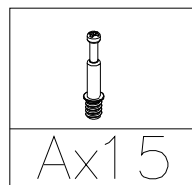
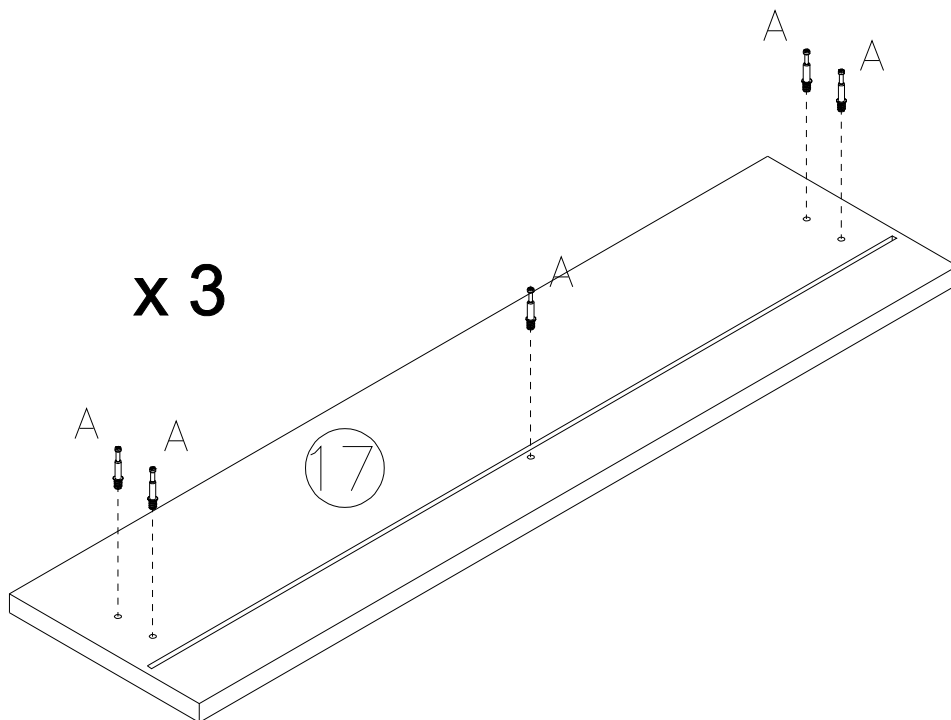
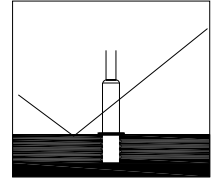
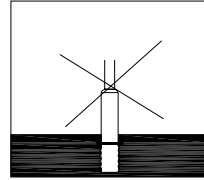
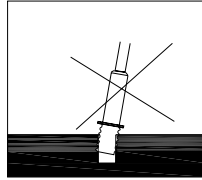
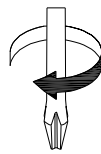

STEP 33

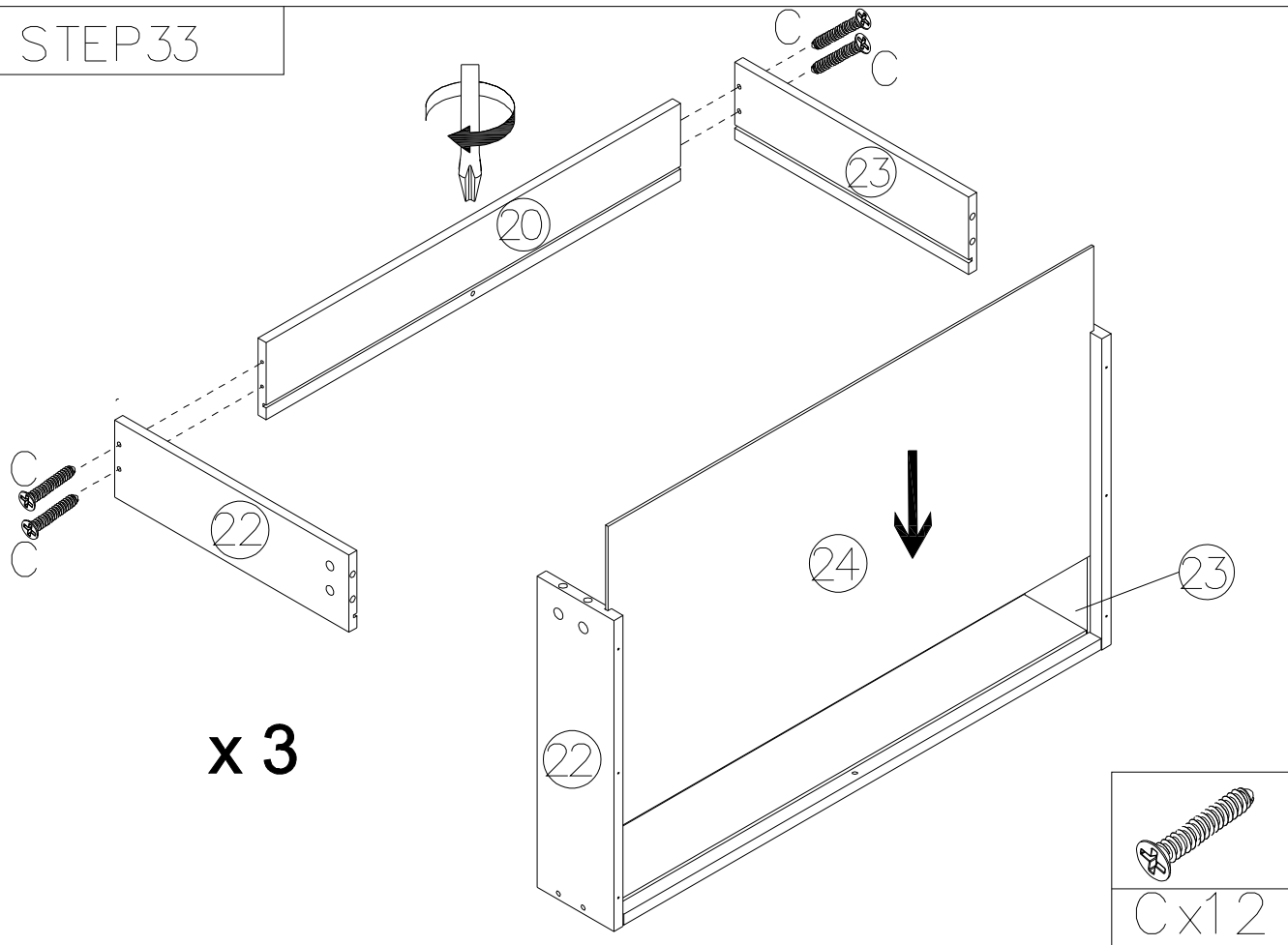

STEP 34

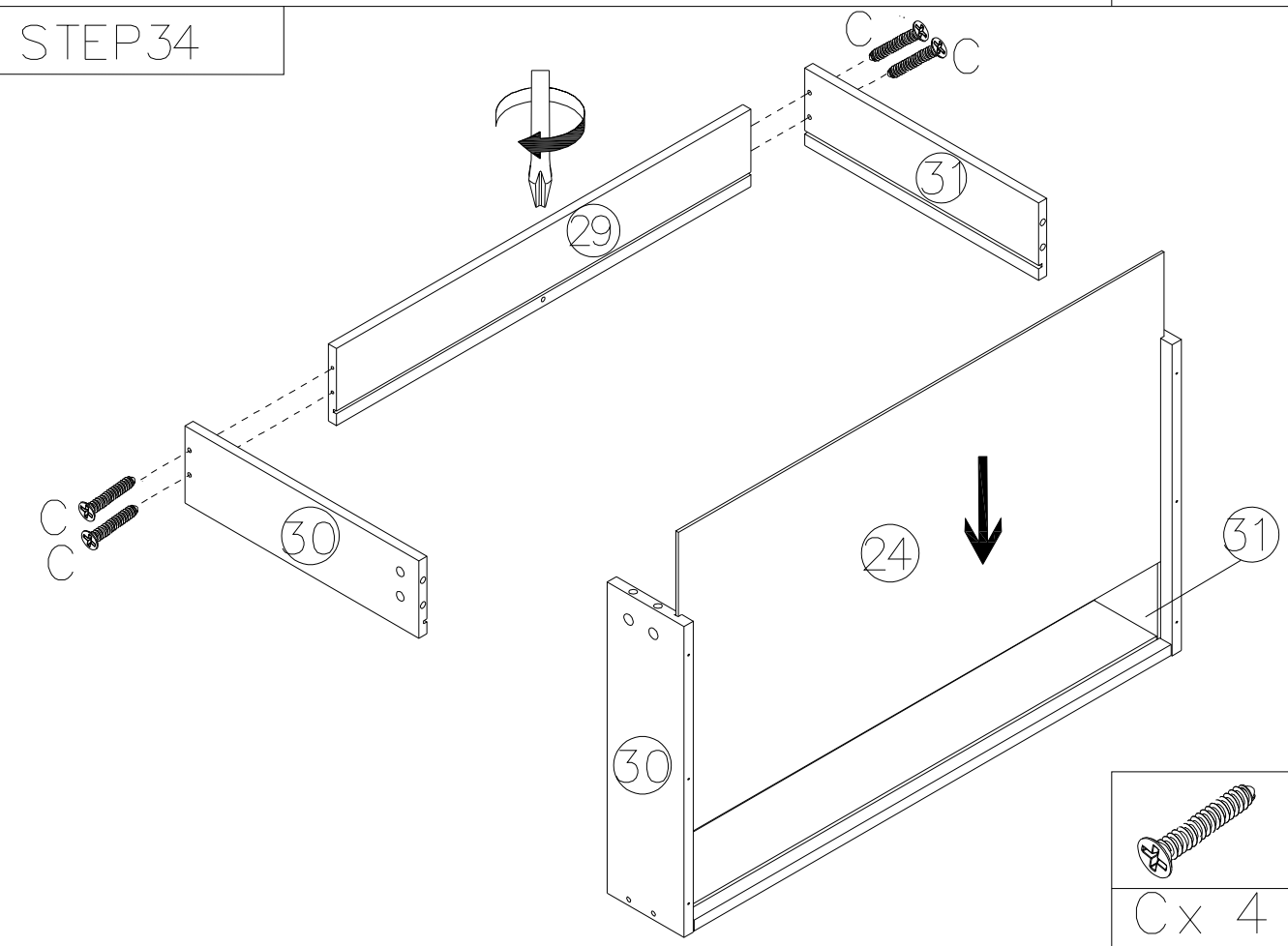

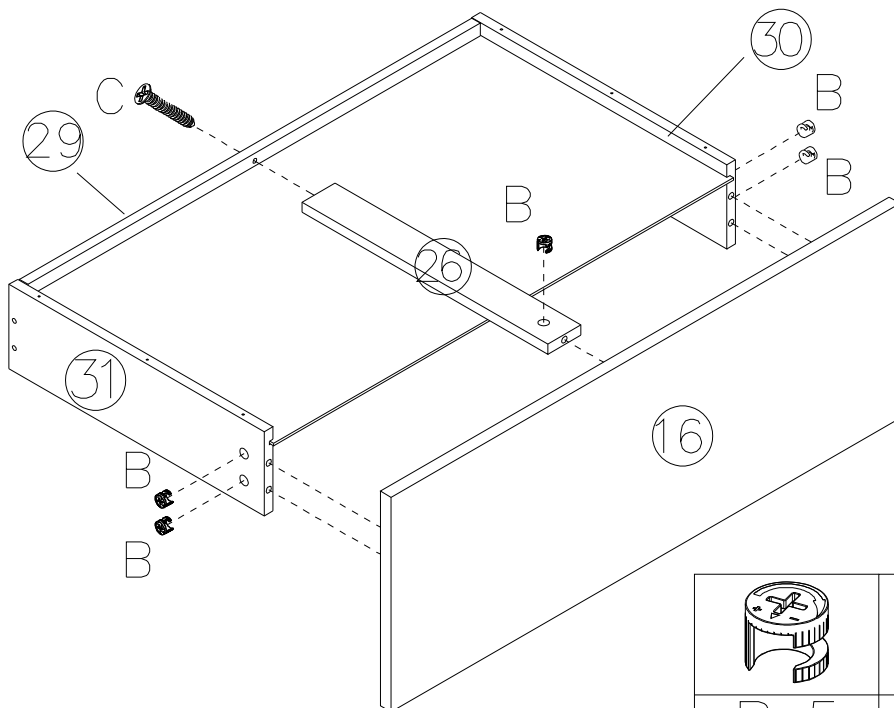
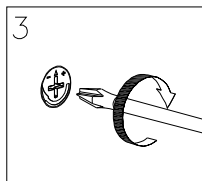
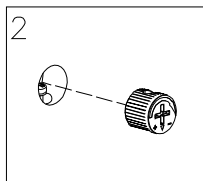
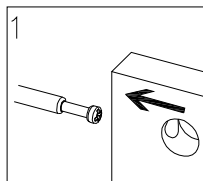
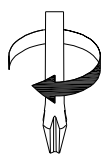

STEP 35

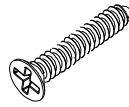

	
Bx5	Cx1

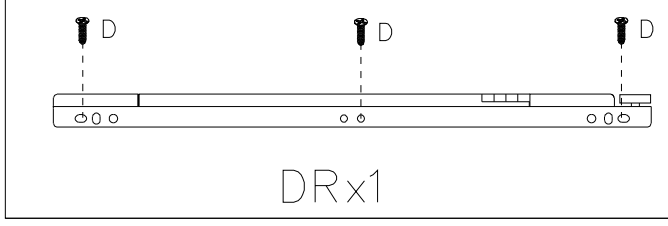
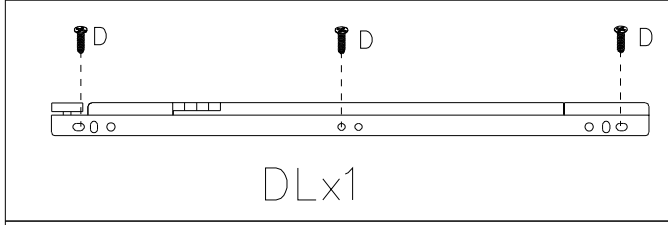
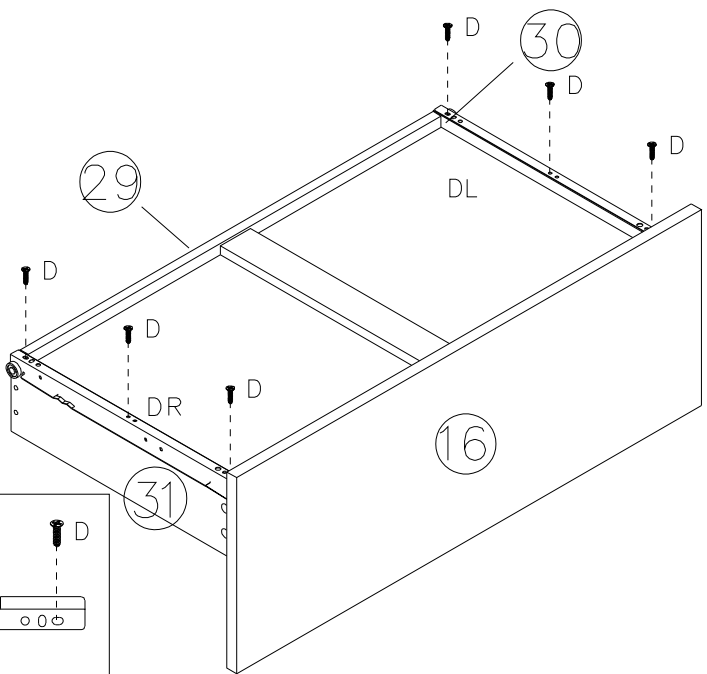
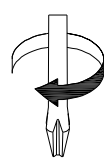
STEP 36



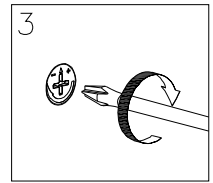
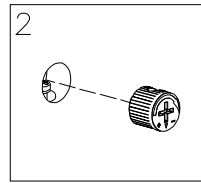
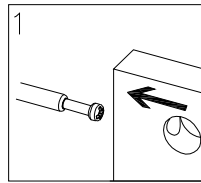
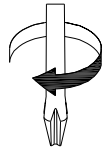

Dx6

STEP 37

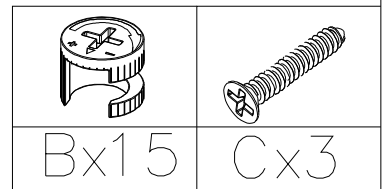
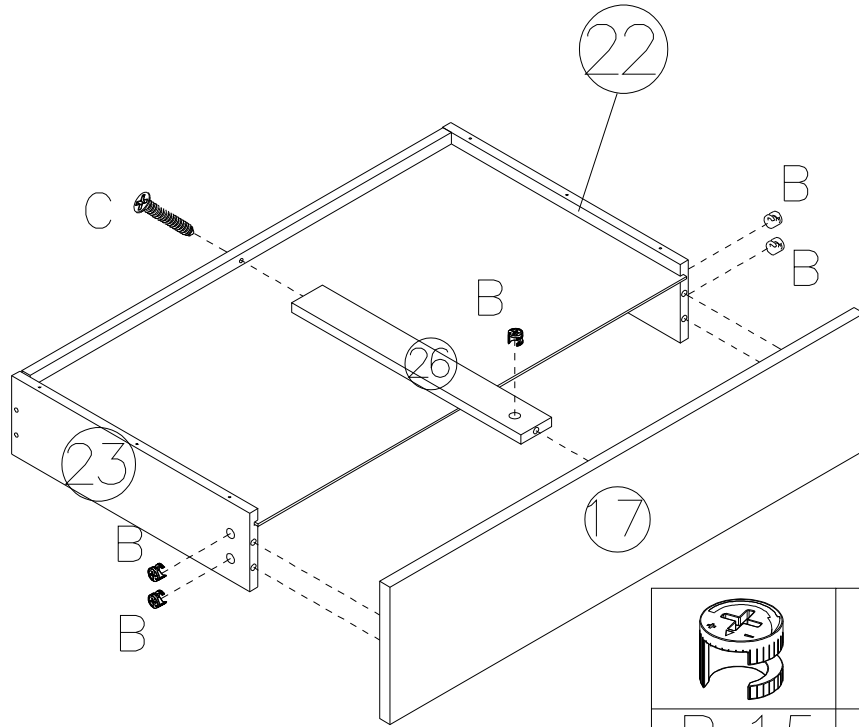

x 3



STEP 38

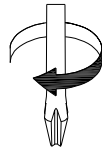

x 3

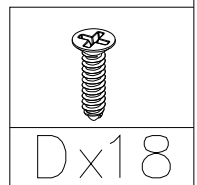
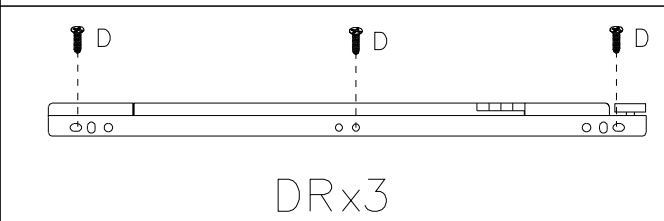
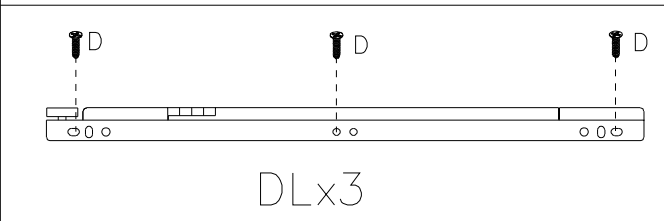
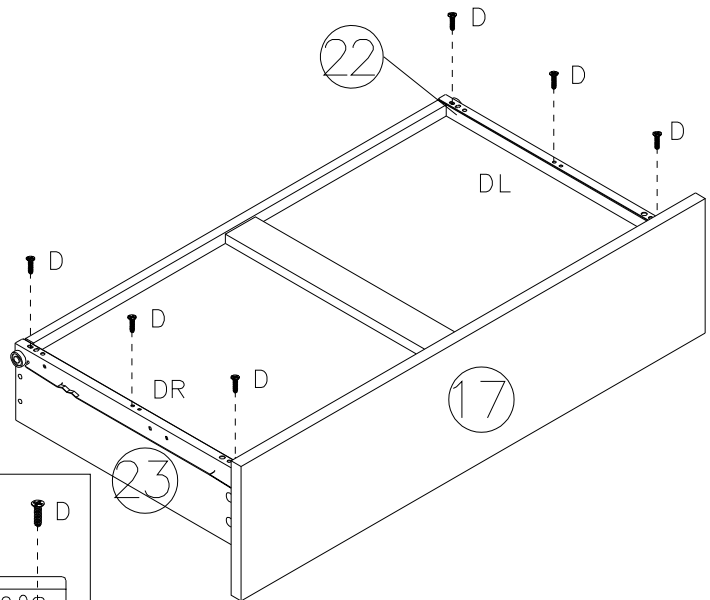

STEP 39

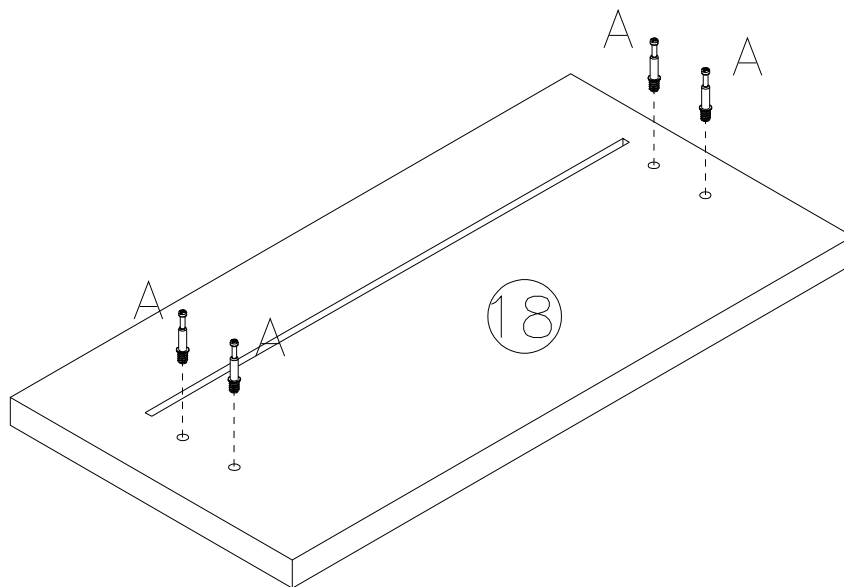
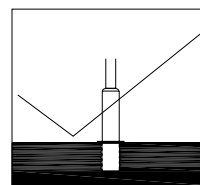
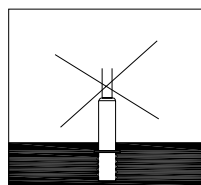
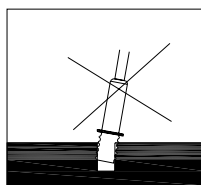

Ax4

STEP 40

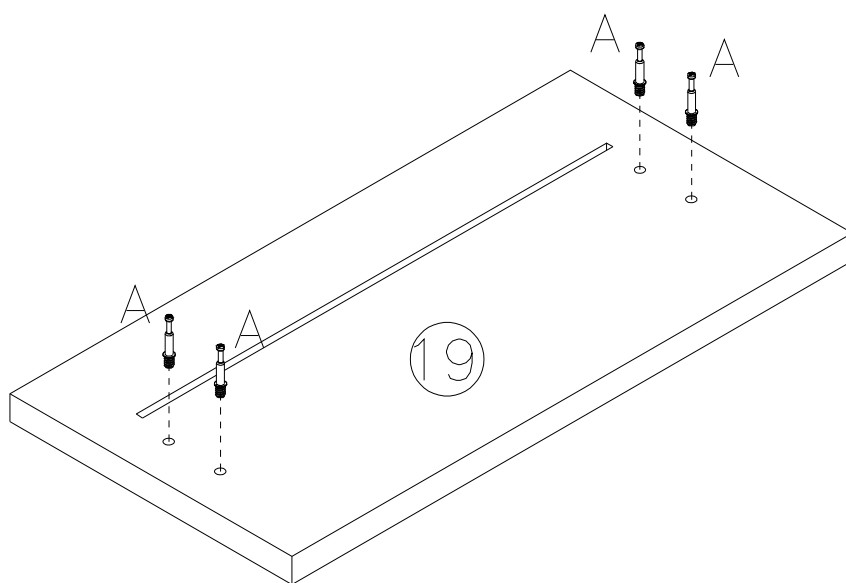
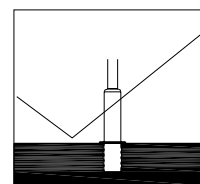
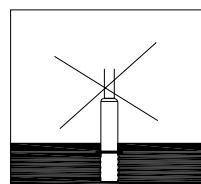
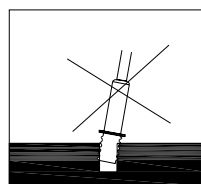
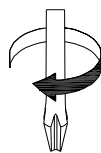

Ax4

STEP41

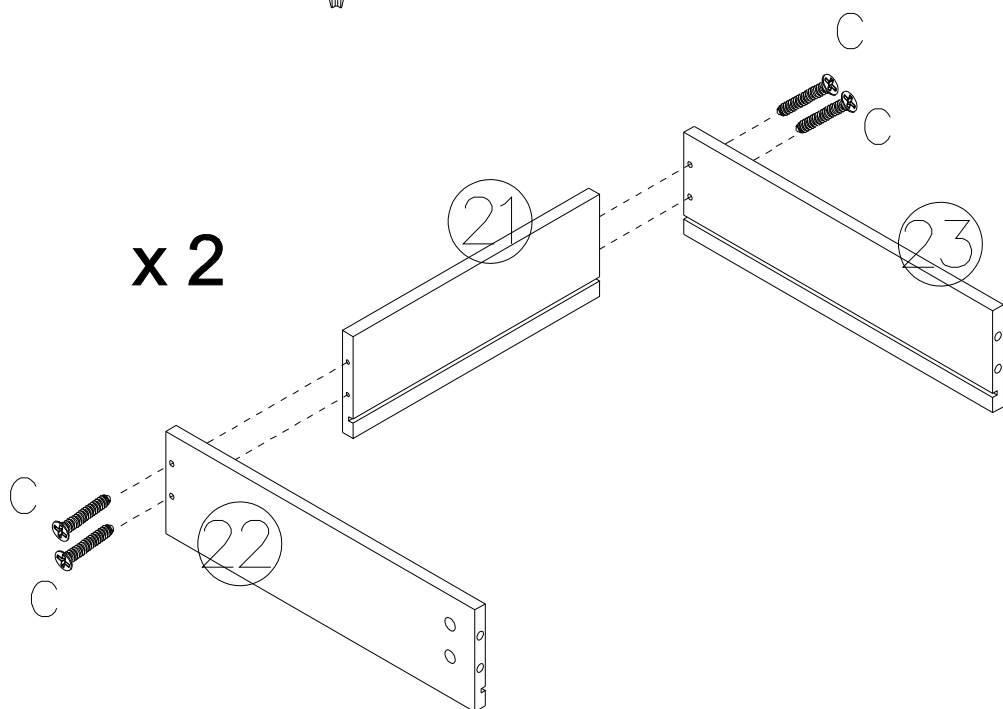
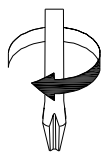

C x 8

STEP42

x 2

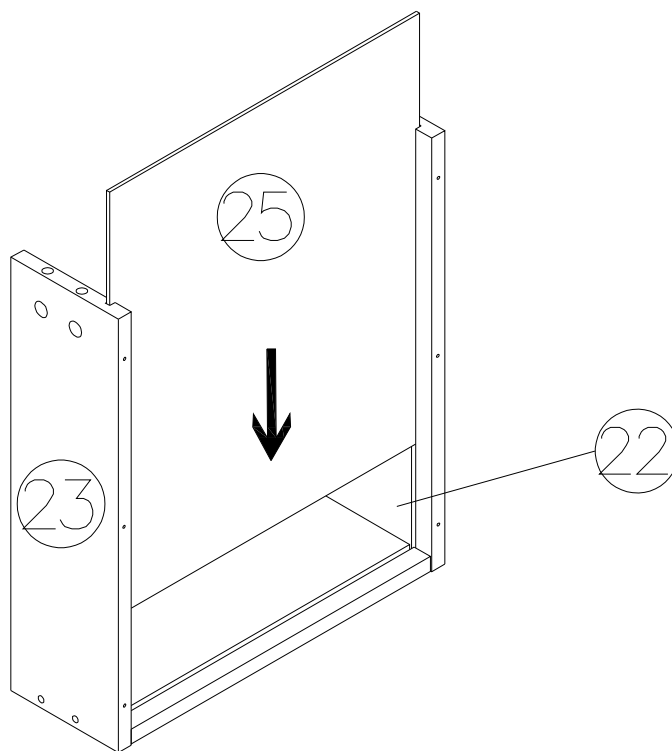

STEP 43

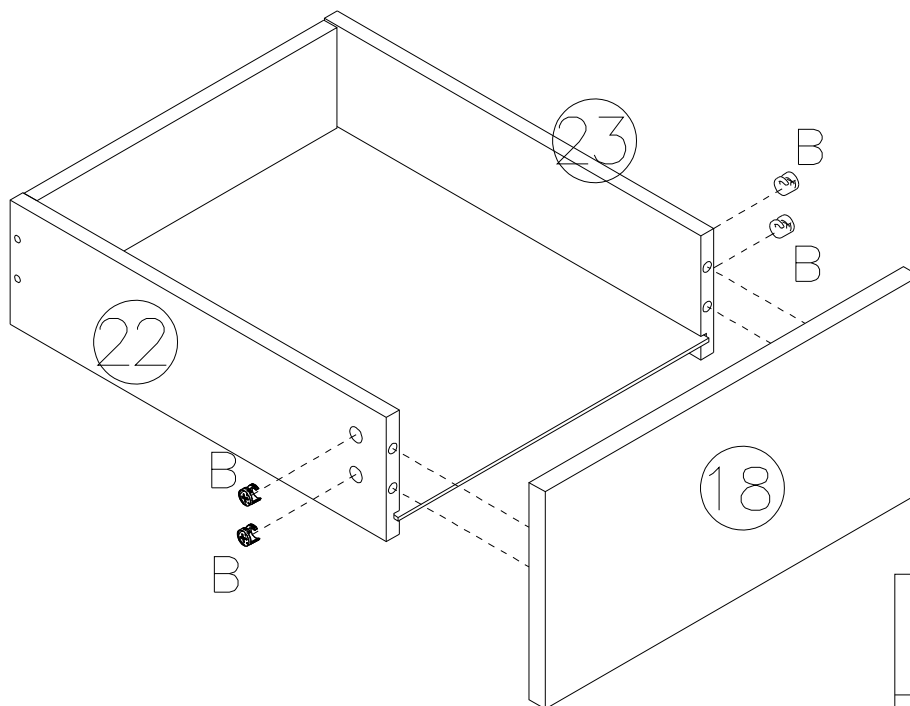
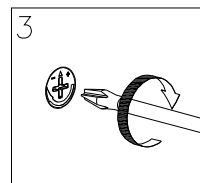
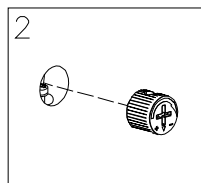
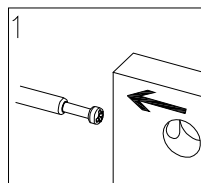
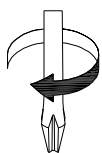

Bx4

STEP 44

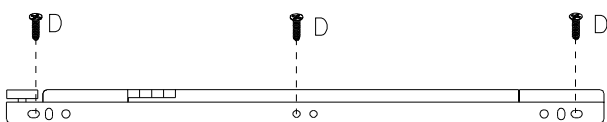
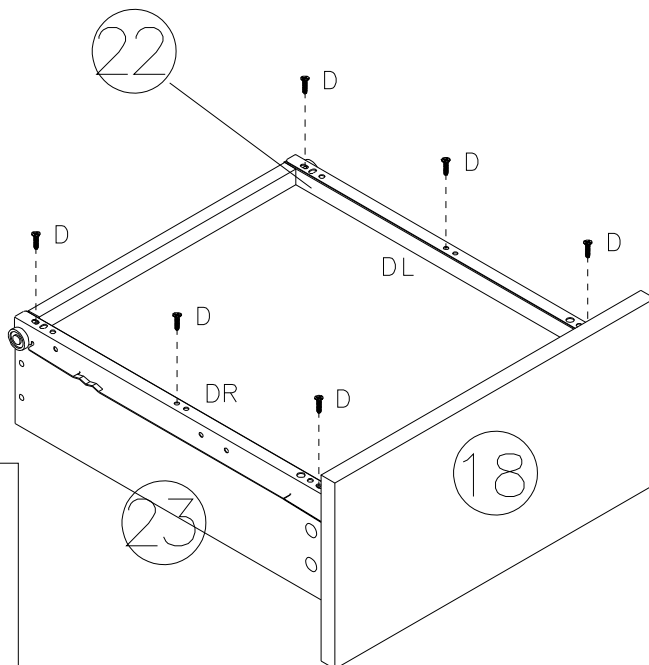

DLx1

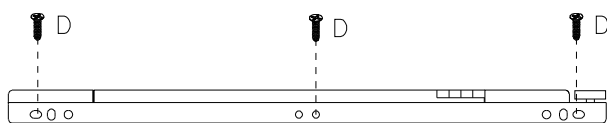

DRx1



Dx6

STEP 45

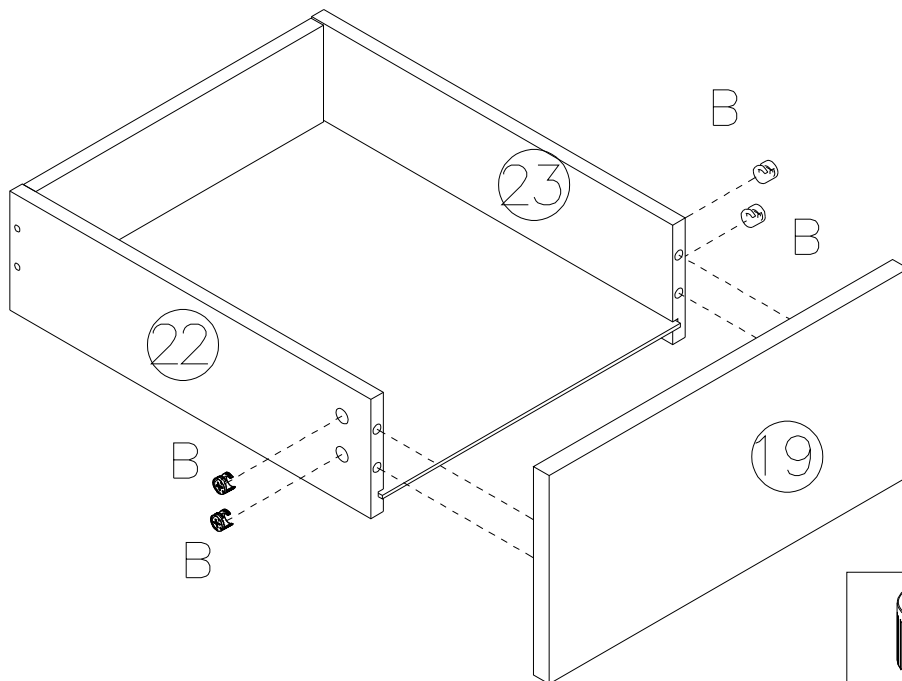
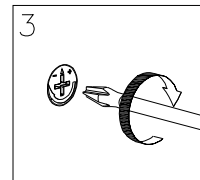
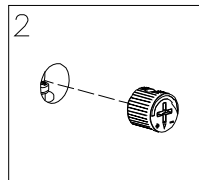
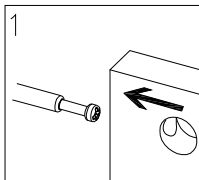
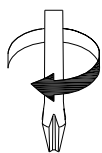

Bx4

STEP 46

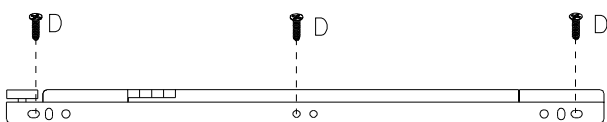
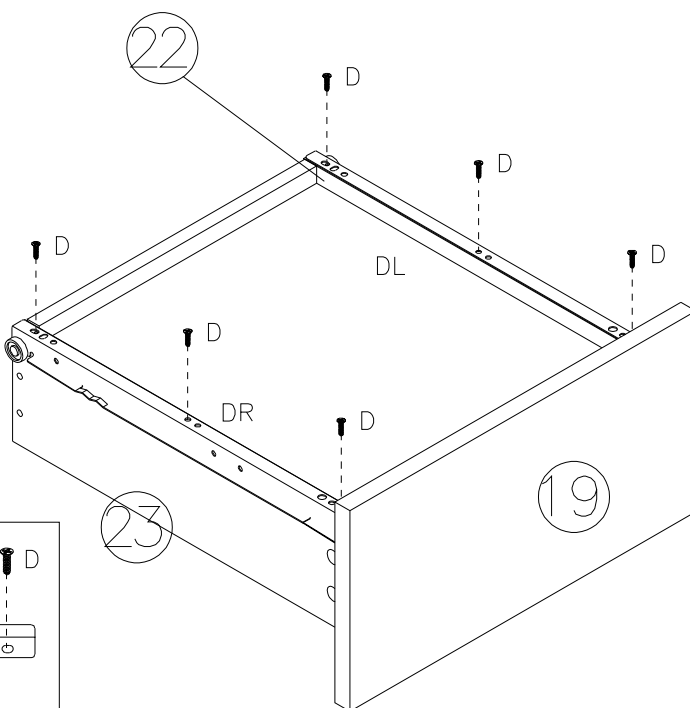
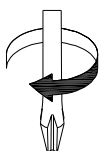

DLx1

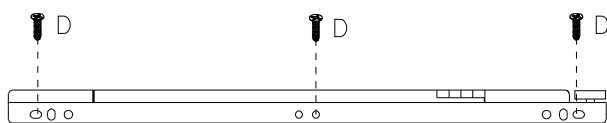

DRx1



Dx6

STEP47

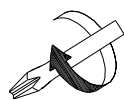

E x 12	I x 12

STEP48

Droll two holes in the wall at the marked position for installing the anti-tip device.

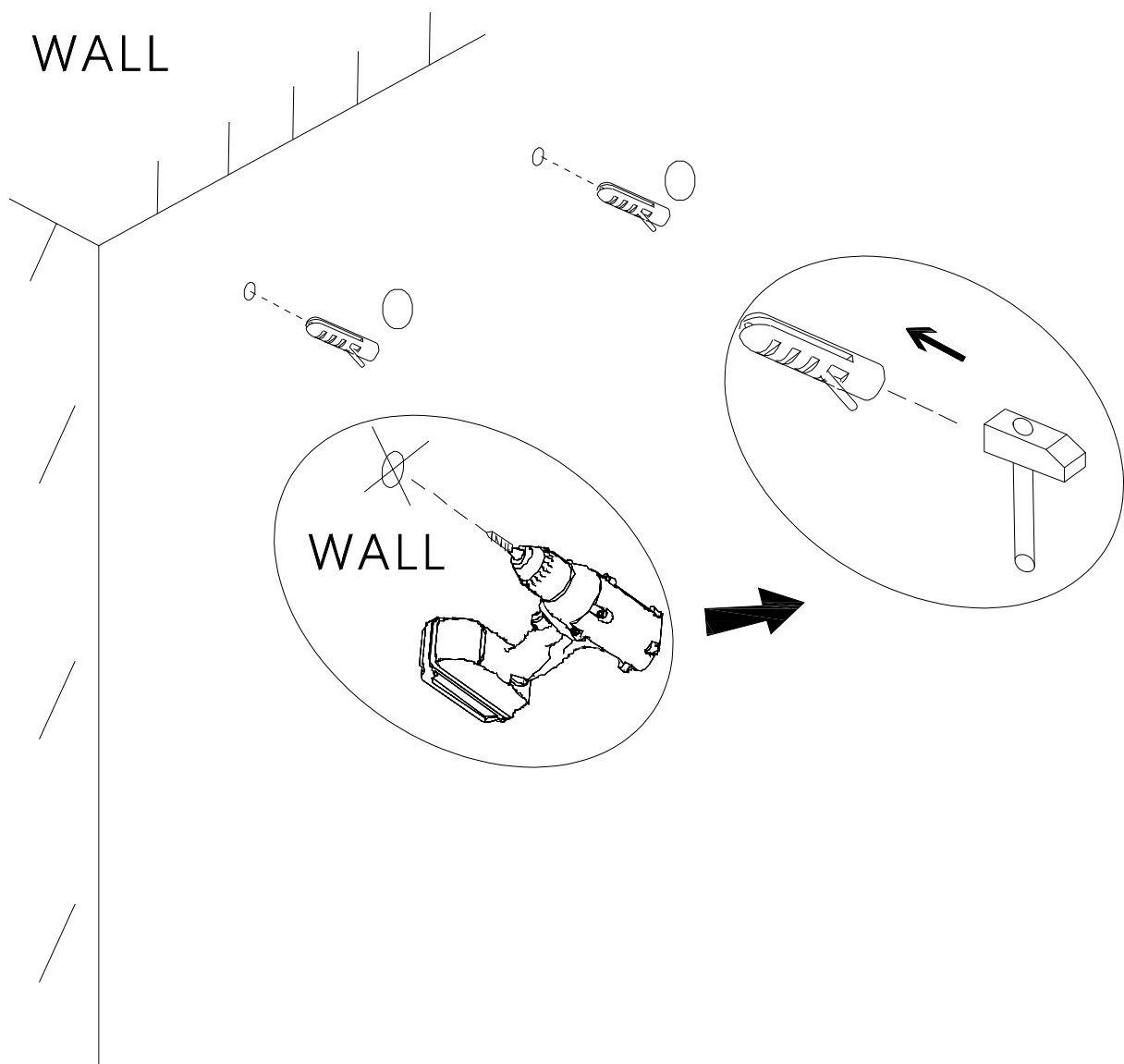

0 x 2

STEP49

Place the cabinet in the desired position, and then use screw L to firmly fix it to the wall.

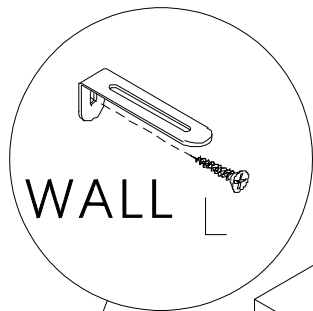

WALL

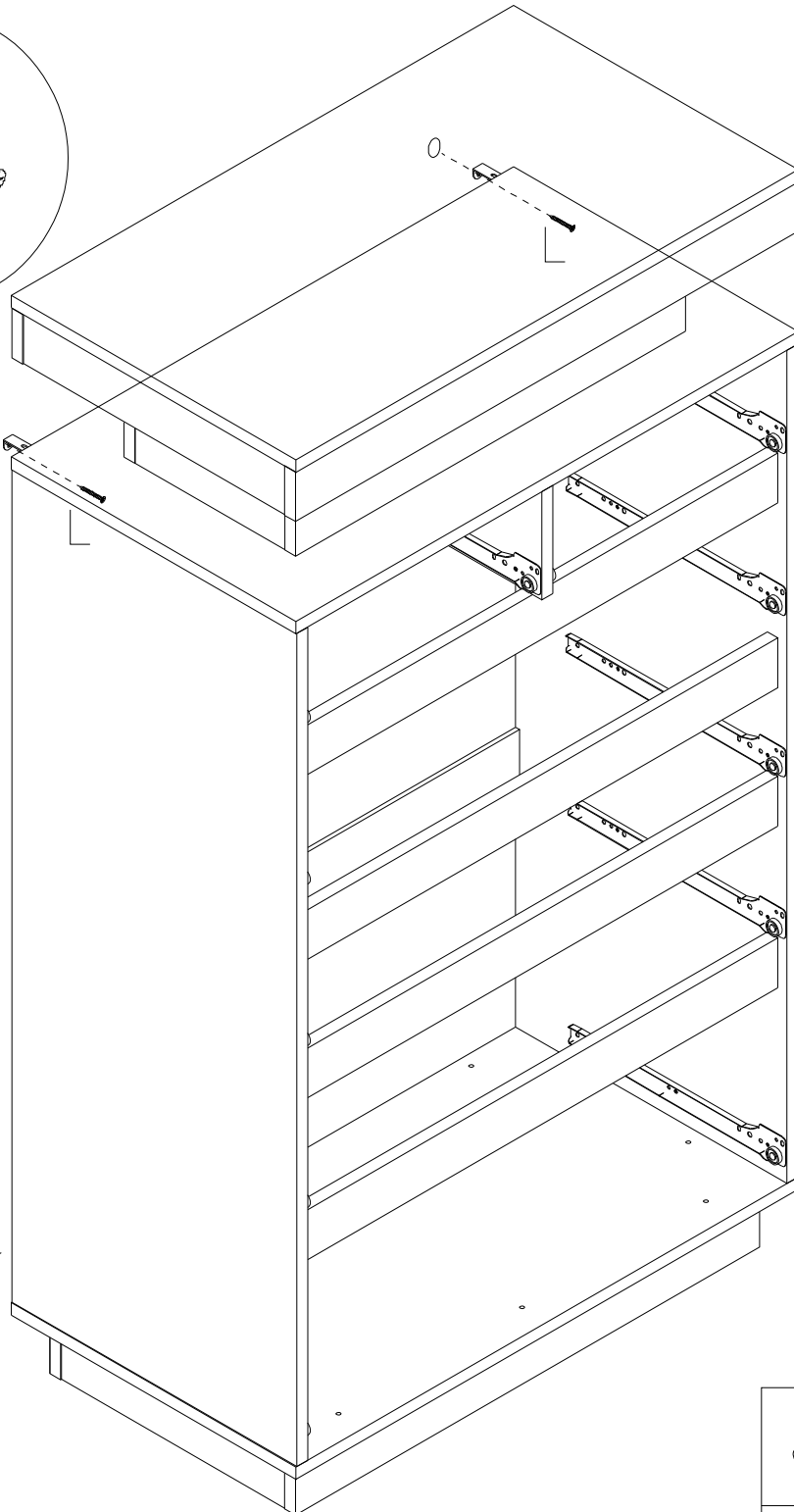

Lx2

STEP50

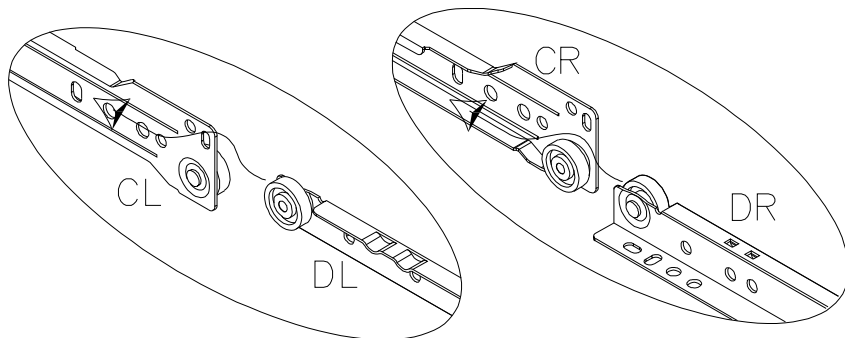
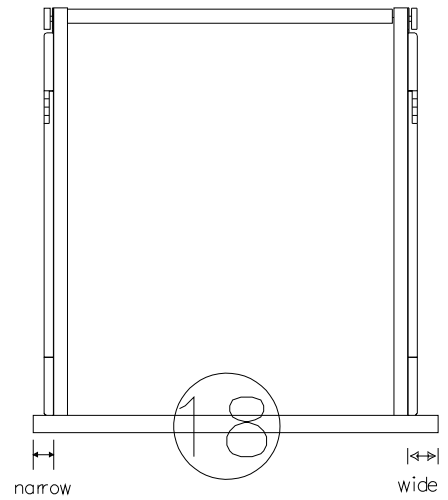
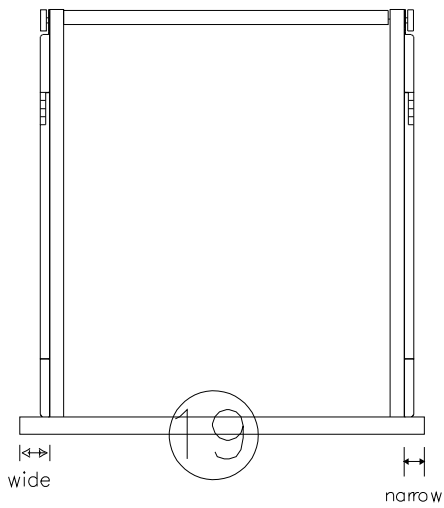
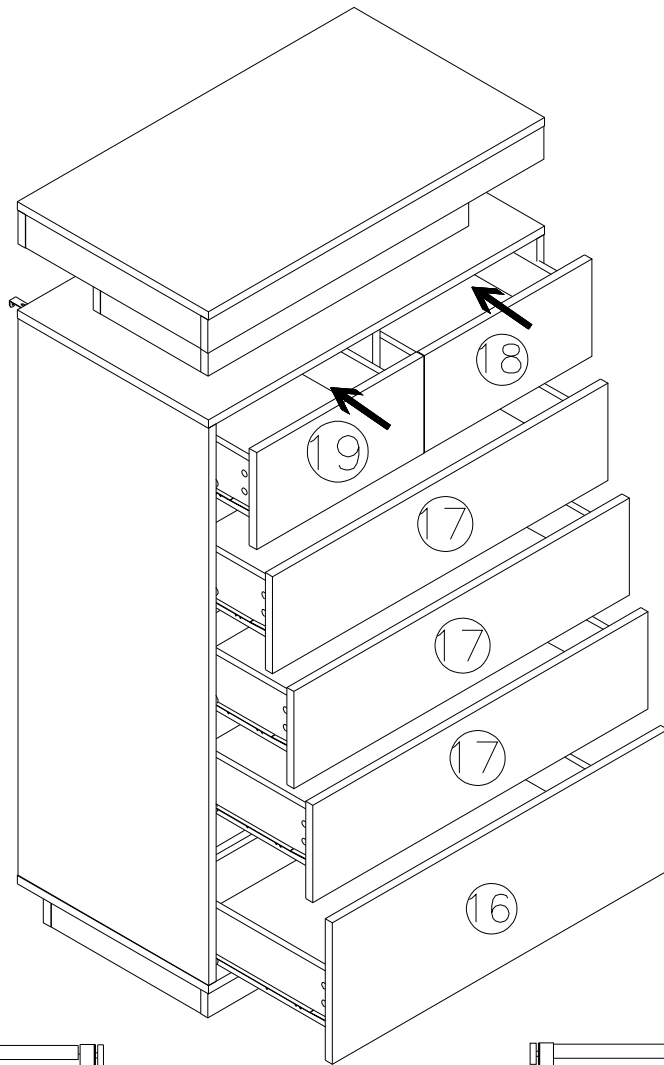

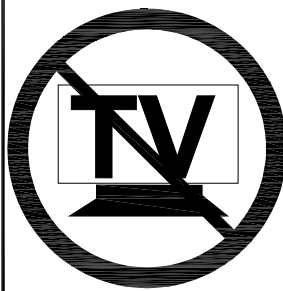

Children have died from furniture tipover. To reduce the risk of furniture tipover:

- ALWAYS install Anti-tip device provided.
- For use with televisions weighing 30 lb or less. Use with heavier televisions may result in instability causing tip-over resulting in death or serious injury.
- NEVER allow children to stand, climb or hang on any drawers, doors, or shelves.
- NEVER open more than one drawer at a time.
- Place heaviest items in the lowest drawers.

***This is a permanent label.
Do not remove!***

