

ASSEMBLY INSTRUCTIONS

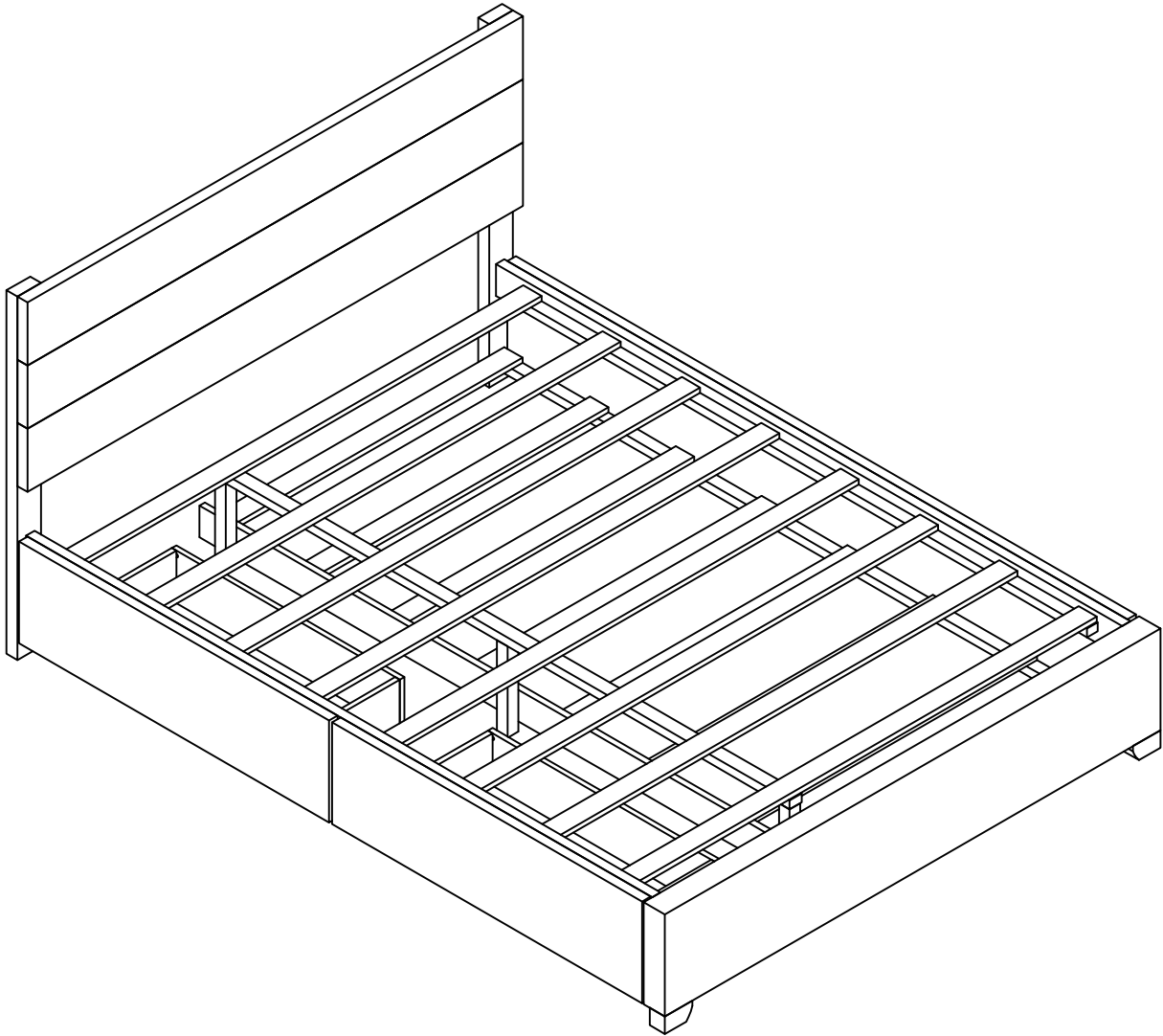









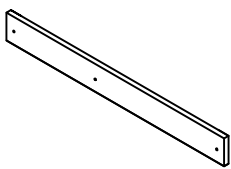

IMPORTANT NOTE

****PLACE ALL PARTS ON A CLEAN AND SMOOTH SURFACE SUCH AS A RUG OR CARPET TO AVOID THE PARTS FROM BEING SCRATCHED**

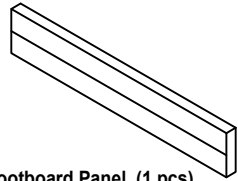
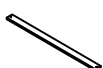

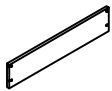
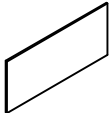
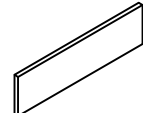

**** BEFORE YOU BEGIN , KINDY FOLLOW THE ASSEMBLY INSTRUCTIONS STEP BY STEP**

****DO NOT TIGHTEN ALL SCREWS AND BOLTS UNTIL THE BED IS FULLY SET-UP**



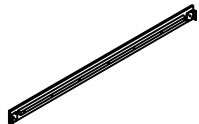
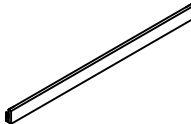
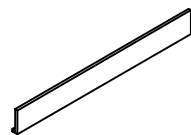

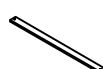



ASSEMBLY INSTRUCTIONS

1  Lower Bed Panel (3 pcs)	2  Connection Bar (1 pc)	
3  Left Metal Plate (1 pc)	4  Right Metal Plate (1 pc)	5  Footboard Panel (1 pcs)
6  Roll Slat (8 pcs) 1365*60*15	7  Leg (2 pcs)	8  Left Wheel Board (2pcs)
9  Right Wheel Board (2 pcs)	10  Stand in Pull Box (4pcs)	11  Side Pull Box (4pcs)
12  Back Panel Pull Box (2 pcs)	13  Pull Box Bottom Board (2 pcs)	14  Pull Box Bottom Board (2pcs)

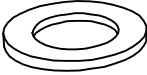
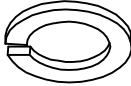
PART LIST BOX 2: WF 294632

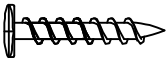
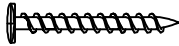
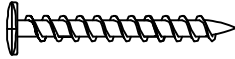
15  Left Lower Rail (1 pc)	16  Right Lower Rail (1pc)	17  Front Panel Trundle (1 pc)
18  Back Panel Trundle (1 pc)	19  Roll Slat (8 pcs) 985*60*15	20  Center Rail (1 pc)
21  Bed Slat Support With Leveler (3 pcs)		





ASSEMBLY INSTRUCTIONS

<p>A</p>  <p>(Ø 5/16 "X25mm) Short Bolt (8pcs)</p>	<p>B</p>  <p>(Ø 5/16 "X38mm) Long Bolt (9 pcs)</p>	<p>C</p>  <p>(Ø 5/16 "X55mm) Long Bolt (2 pcs)</p>
<p>D</p>  <p>(Ø 5/16 "-RBW) Flat Washer (19 pcs)</p>	<p>E</p>  <p>(Ø 5/16 "-RBW) Spring Washer (19 pcs)</p>	<p>F</p>  <p>(M4x75mm x32mm) Allen Wrench (1 pc)</p>
<p>G</p>  <p>(m4x20mm-RBW) Flat Head Screw (72 pcs)</p>	<p>H</p>  <p>(m4x30mm-RBW) Flat Head Screw (44 pcs)</p>	<p>I</p>  <p>(m4x38mm-RBW) Flat Head Screw (24 pcs)</p>
<p>J</p>  <p>(38mmx38mmx25mmx2mm) Square Patch (4 pcs)</p>	<p>K</p>  <p>(Ø10x10mmx10mm) Plastic Button (24 pcs)</p>	<p>L</p>  <p>(m41x25mmx50mm) Wheels (12 pcs)</p>

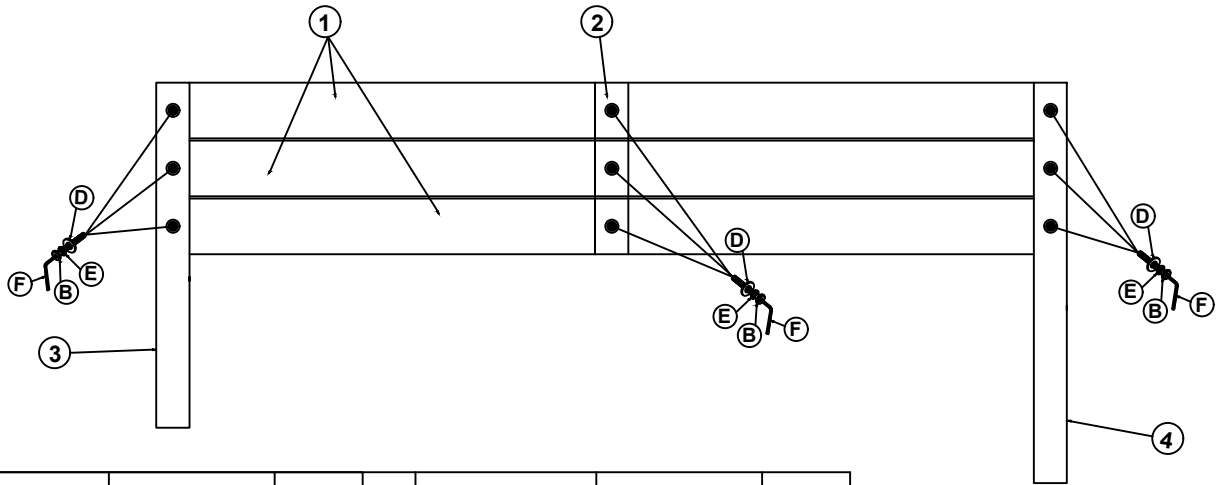
ASSEMBLY INSTRUCTIONS





STEP 1

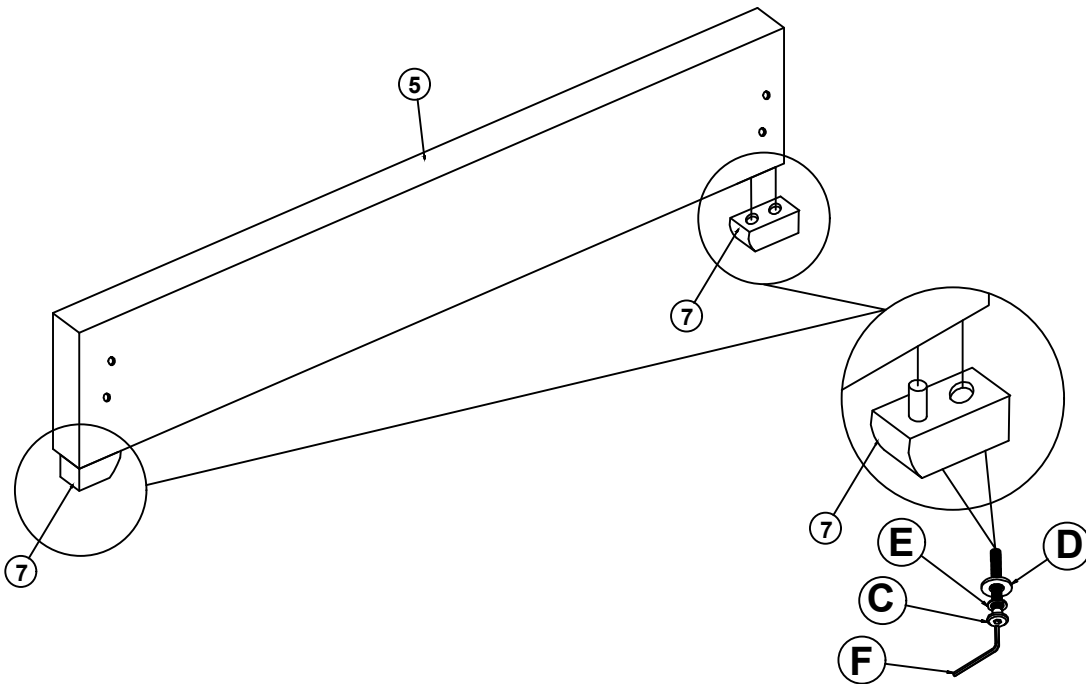

B	Bolt (Ø 5/16 "X38mm)		9pcs	D	Flat Washer (Ø 5/16 "RBW)		9pcs
E	Spring Washer (Ø 5/16 "RBW)		9pcs	F	Allen Wrench (M4x75mm x32mm)		1pc

STEP 2





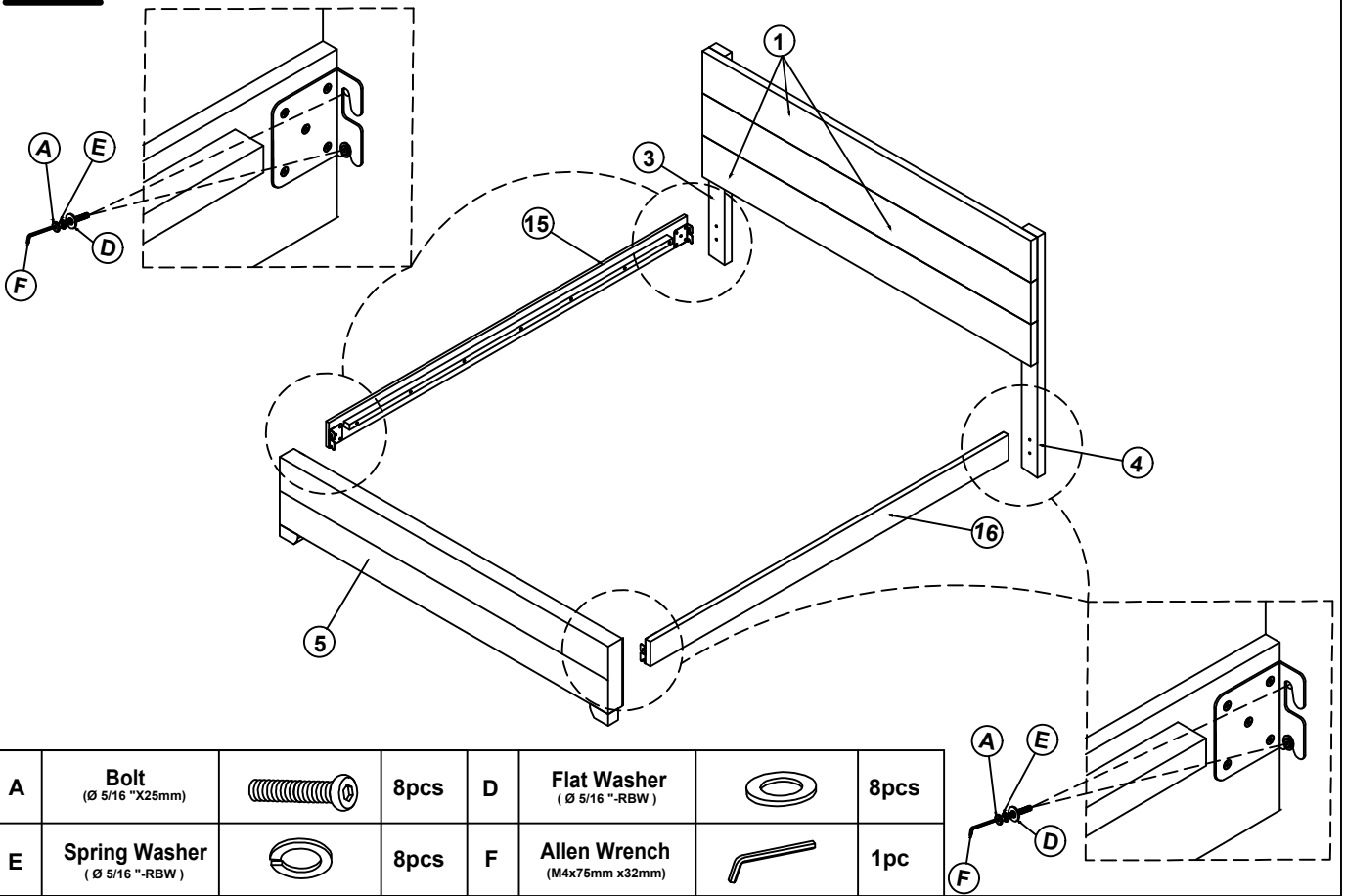

C	Bolt (Ø 5/16 "X55mm)		2pcs	D	Flat Washer (Ø 5/16 "RBW)		2pcs
E	Spring Washer (Ø 5/16 "RBW)		2pcs	F	Allen Wrench (M4x75mm x32mm)		1pc

ASSEMBLY INSTRUCTIONS

STEP 3



A	Bolt (Ø 5/16 "X25mm)		8pcs	D	Flat Washer (Ø 5/16 "-RBW)		8pcs
E	Spring Washer (Ø 5/16 "-RBW)		8pcs	F	Allen Wrench (M4x75mm x32mm)		1pc

STEP 4

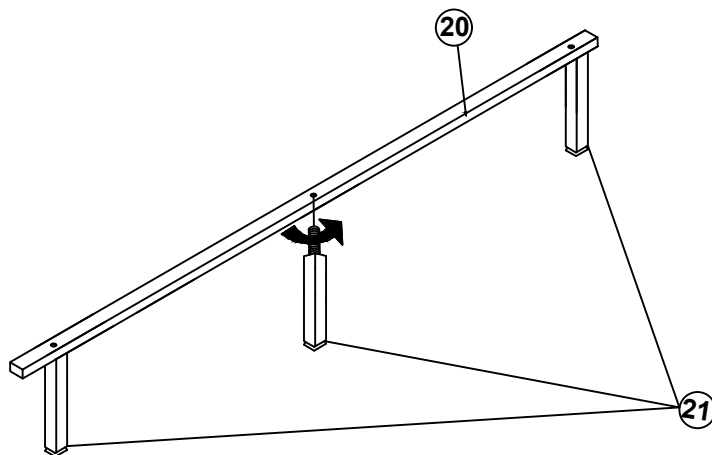

ASSEMBLY INSTRUCTIONS

STEP 5

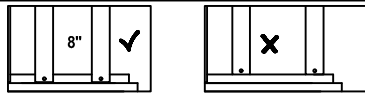
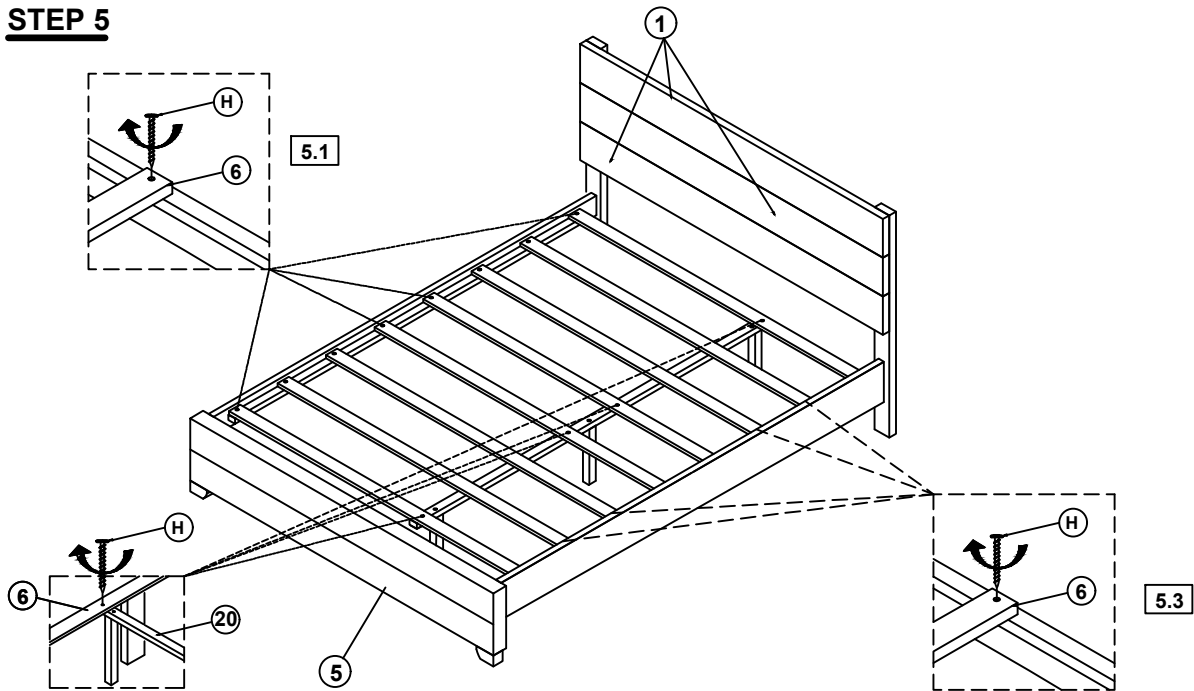

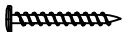

NOTE: Do not lock the screws of the trundle slats to the utermost edge the trundle slats, you need to leave a certain space at the edges, otherwise it will cause the board to break.

H	Flat Head Screw (m4x30mm-RBW)		20pcs
---	----------------------------------	---	-------

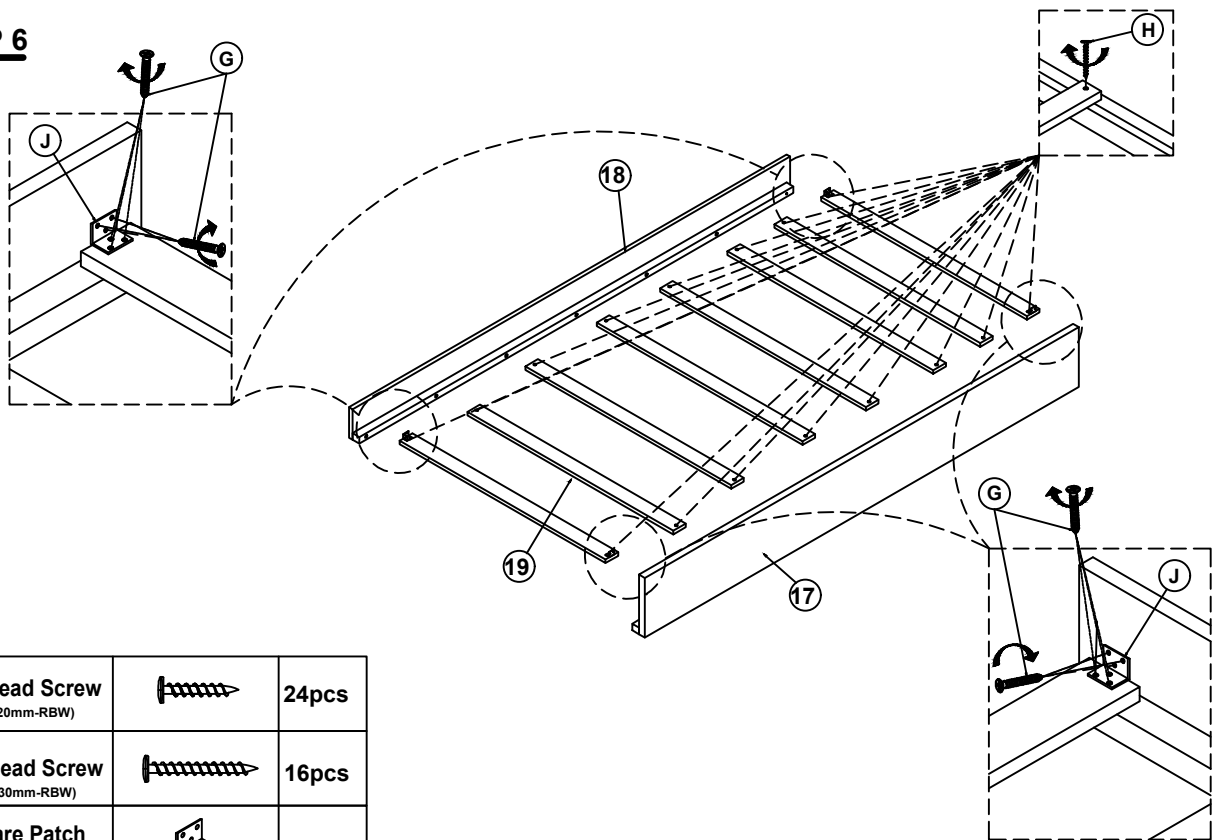
STEP 6

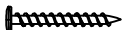



G	Flat Head Screw (m4x20mm-RBW)		24pcs
H	Flat Head Screw (m4x30mm-RBW)		16pcs
J	Square Patch (38mmx38mmx25mmx2mm)		4pcs

ASSEMBLY INSTRUCTIONS

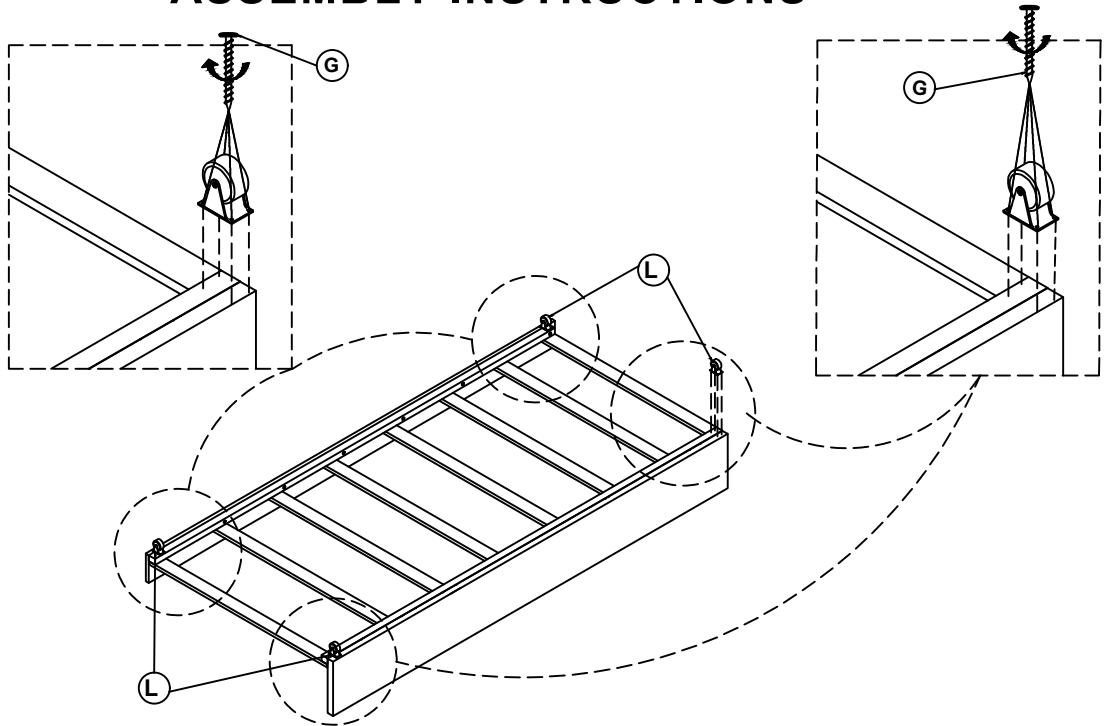
STEP 7



G	Flat Head Screw (m4x20mm-RBW)		16pcs
L	Wheels (m41x25mmx50mm)		4pcs

STEP 8

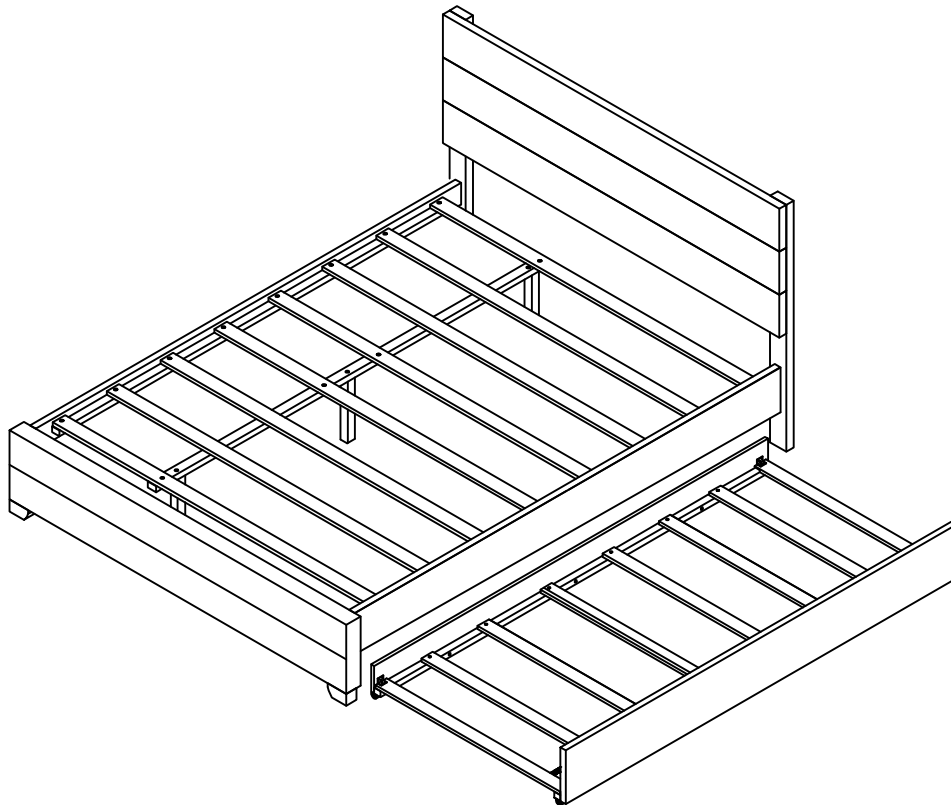

ASSEMBLY INSTRUCTIONS

STEP 9

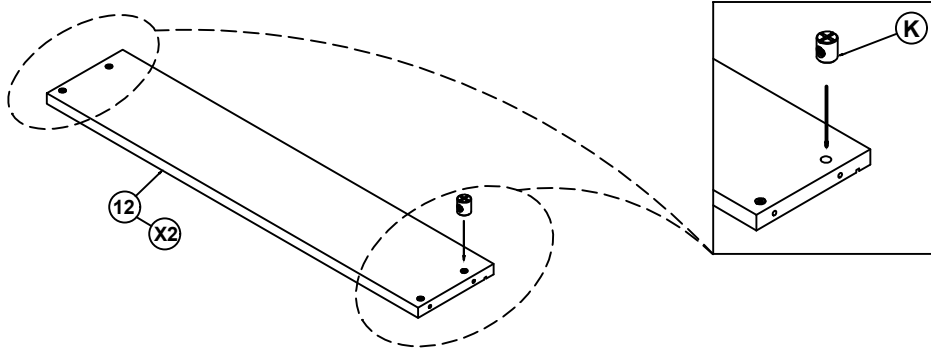

K	Plastic Button (Ø10x10mmx10mm)		8pcs
---	-----------------------------------	---	------

STEP 10

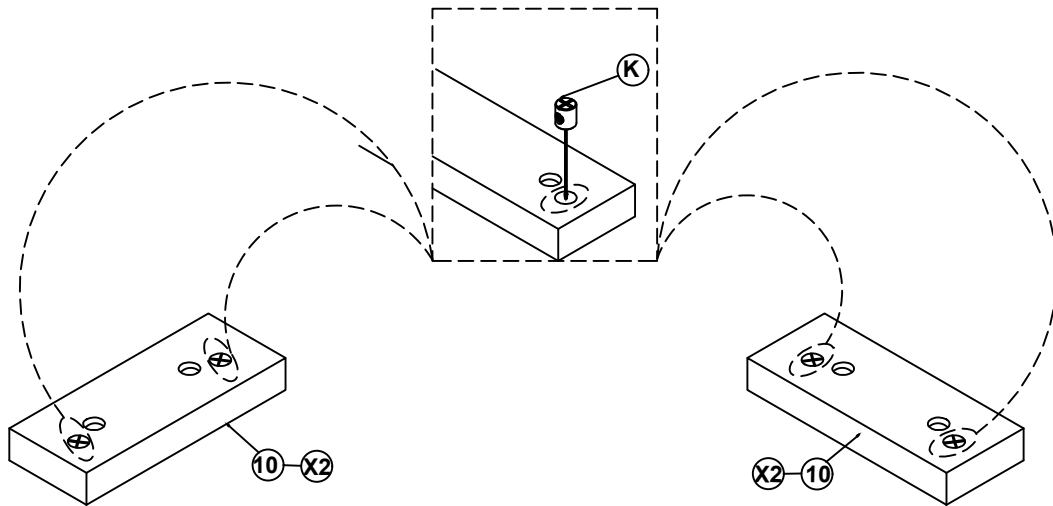

K	Plastic Button (Ø10x10mmx10mm)		8pcs
---	-----------------------------------	---	------

STEP 11

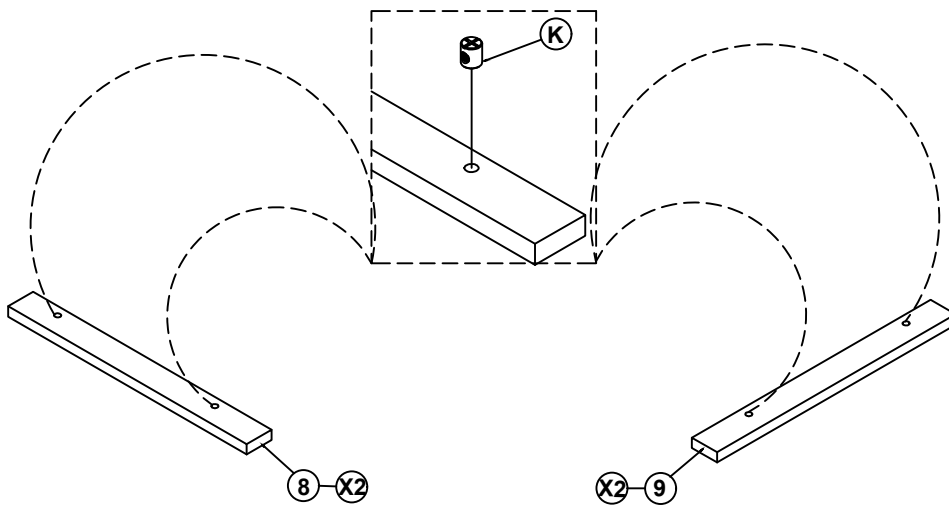

K	Plastic Button (Ø10x10mmx10mm)		8pcs
---	-----------------------------------	---	------

ASSEMBLY INSTRUCTIONS

STEP 12

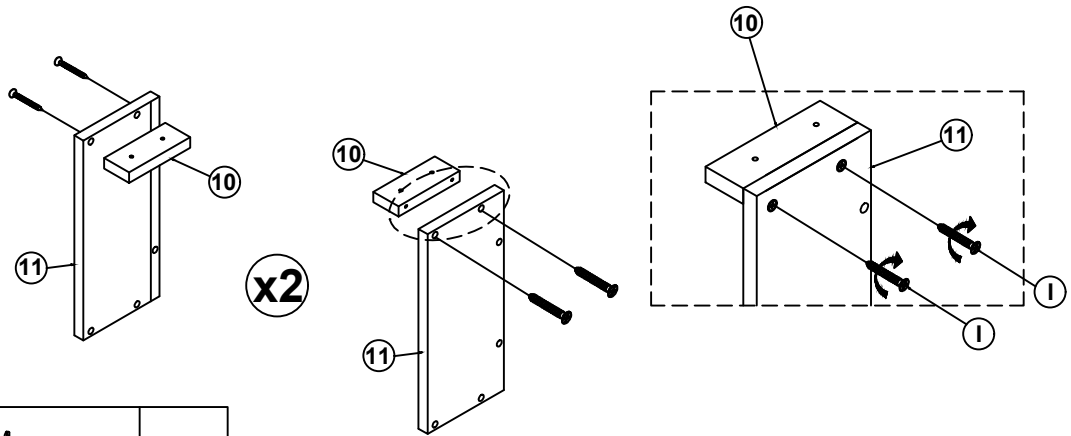

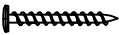
I	Flat Head Screw (m4x38mm-RBW)		8pcs
---	----------------------------------	---	------

STEP 13

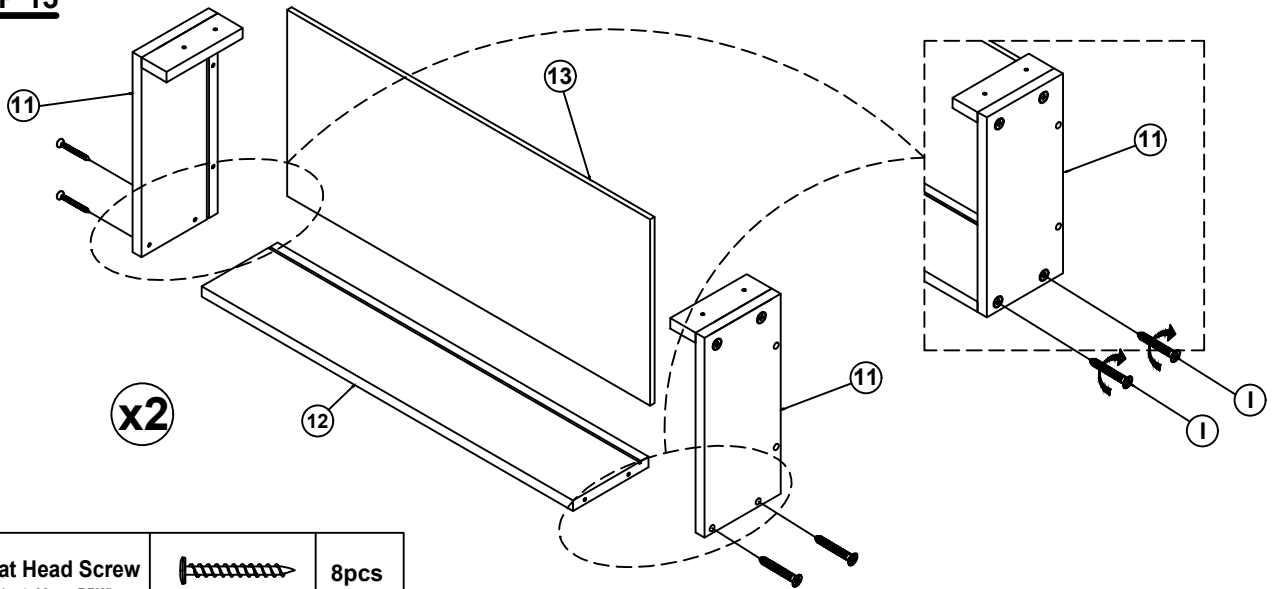

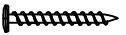
I	Flat Head Screw (m4x38mm-RBW)		8pcs
---	----------------------------------	---	------

STEP 14

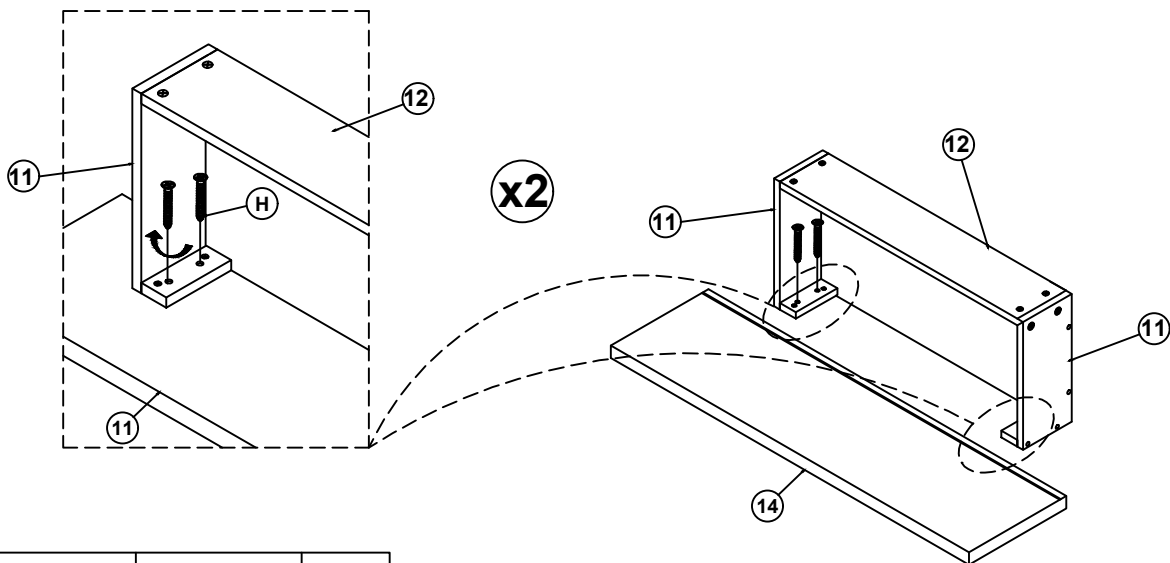

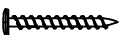
H	Flat Head Screw (m4x30mm-RBW)		8pcs
---	----------------------------------	---	------

ASSEMBLY INSTRUCTIONS

STEP 15

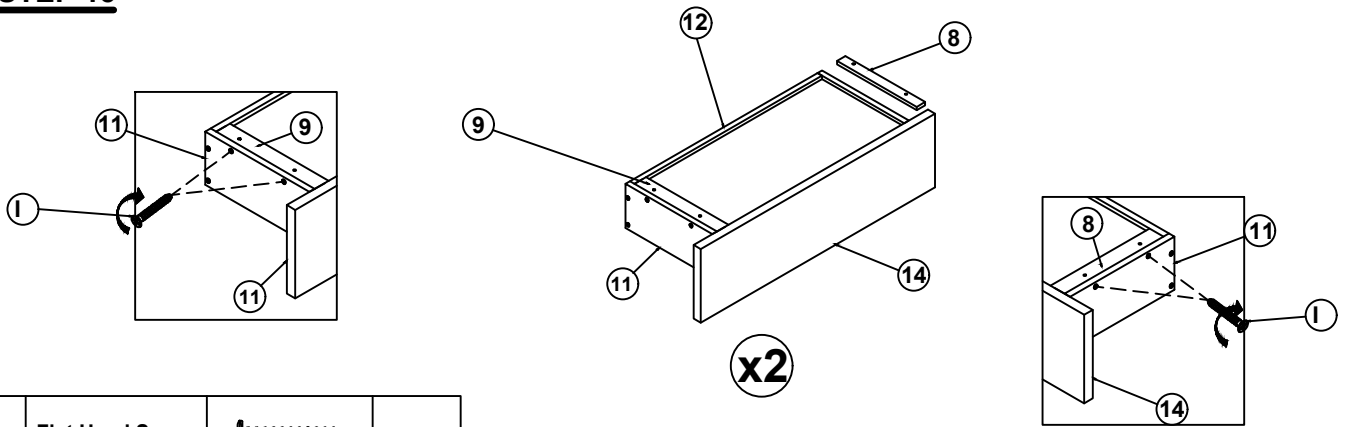

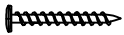
I	Flat Head Screw (m4x38mm-RBW)		8pcs
---	----------------------------------	---	------

STEP 16

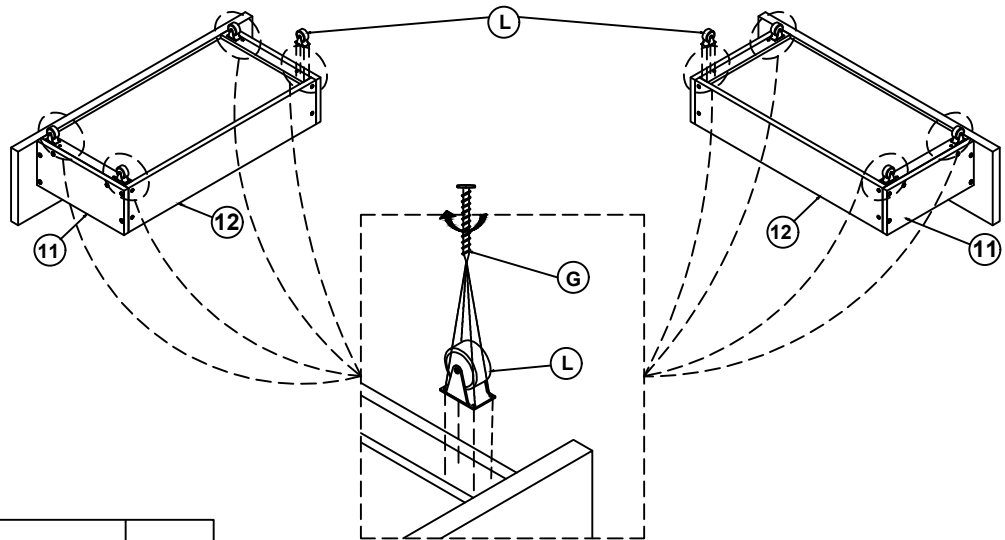

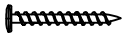
G	Flat Head Screw (m4x20mm-RBW)		32pcs
---	----------------------------------	---	-------

STEP 17 COMPLETE

