

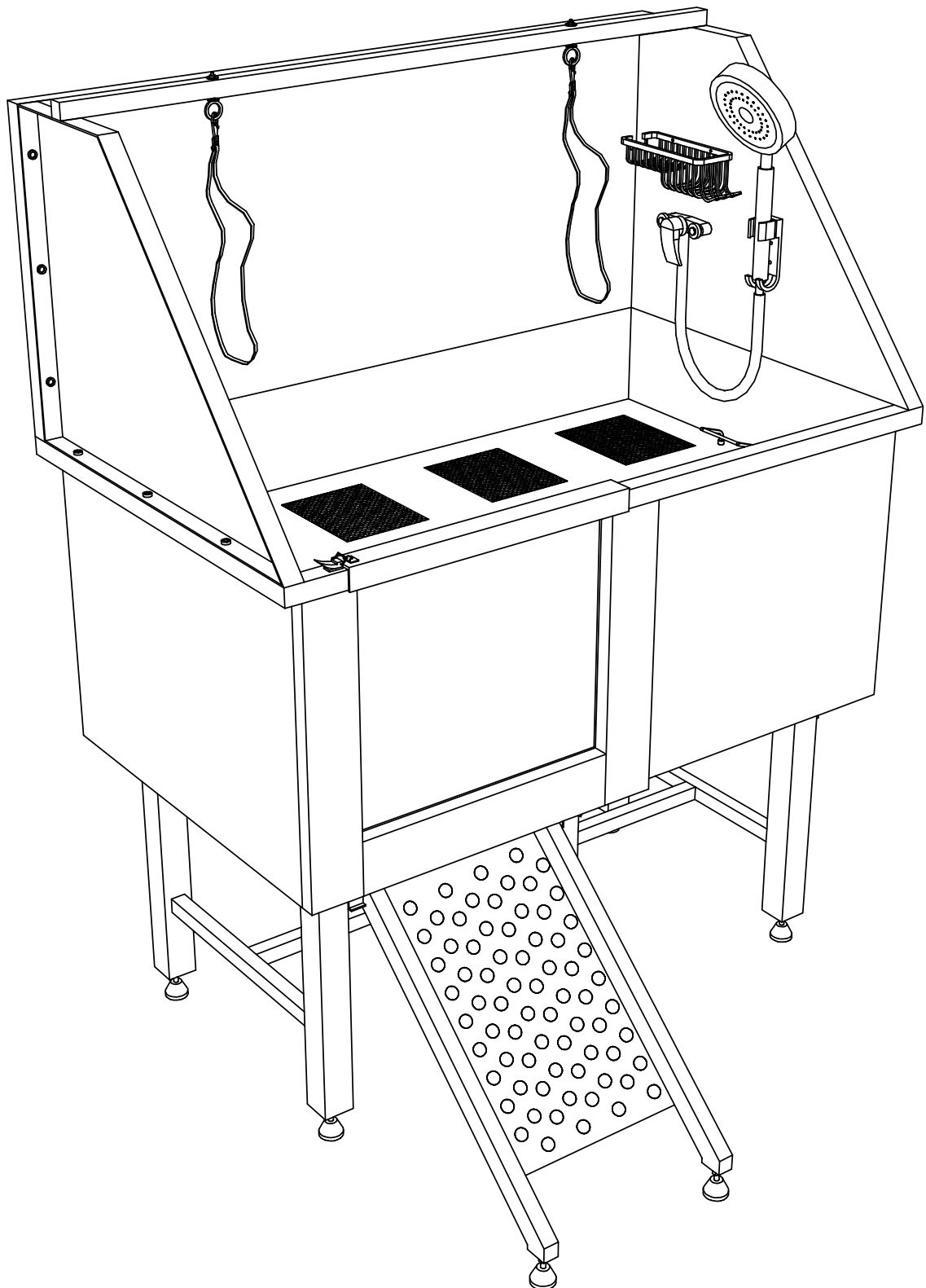

















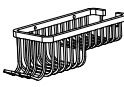





STAINLESS STEEL PET TUB

Assembly Instruction



ATTENTION

Please check if the accessories parts are completely received according to the letter labels and quantity below

PARTS LIST-A					
Item no.	Reference Image	Qty.	Item no.	Reference Image	Qty.
Ⓐ		X1	⑨	 M4X16mm	X4
Ⓑ		X1	⑩	 M6X14mm	X24
Ⓗ		X1	⑪		X6
Ⓘ		X1	⑫		X2
①		X1	⑬		X2
②		X1	⑭		X2
③		X1	⑮		X1
④		X1	⑯		X1
⑤		X2	⑰		X2
⑥		X1	⑱		X1
⑦		X1	⑲		X1
⑧		X1	⑳	 M6X20mm	X2

ATTENTION

Please check if the accessories parts are completely received according to the letter labels and quantity below

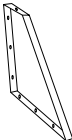
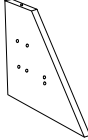
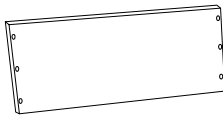
PARTS LIST-B					
Item no.	Reference Image	Qty.	Item no.	Reference Image	Qty.
Ⓒ		X1	Ⓕ		X1
Ⓔ		X1	Ⓖ		X1

1

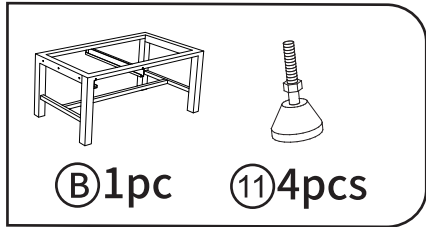

Ensure all protective film is removed from each part prior to installation. And please do not remove the black foam strips on the edges. You can use the wrench (Part 19) to adjust the height of the Leveling Feet.

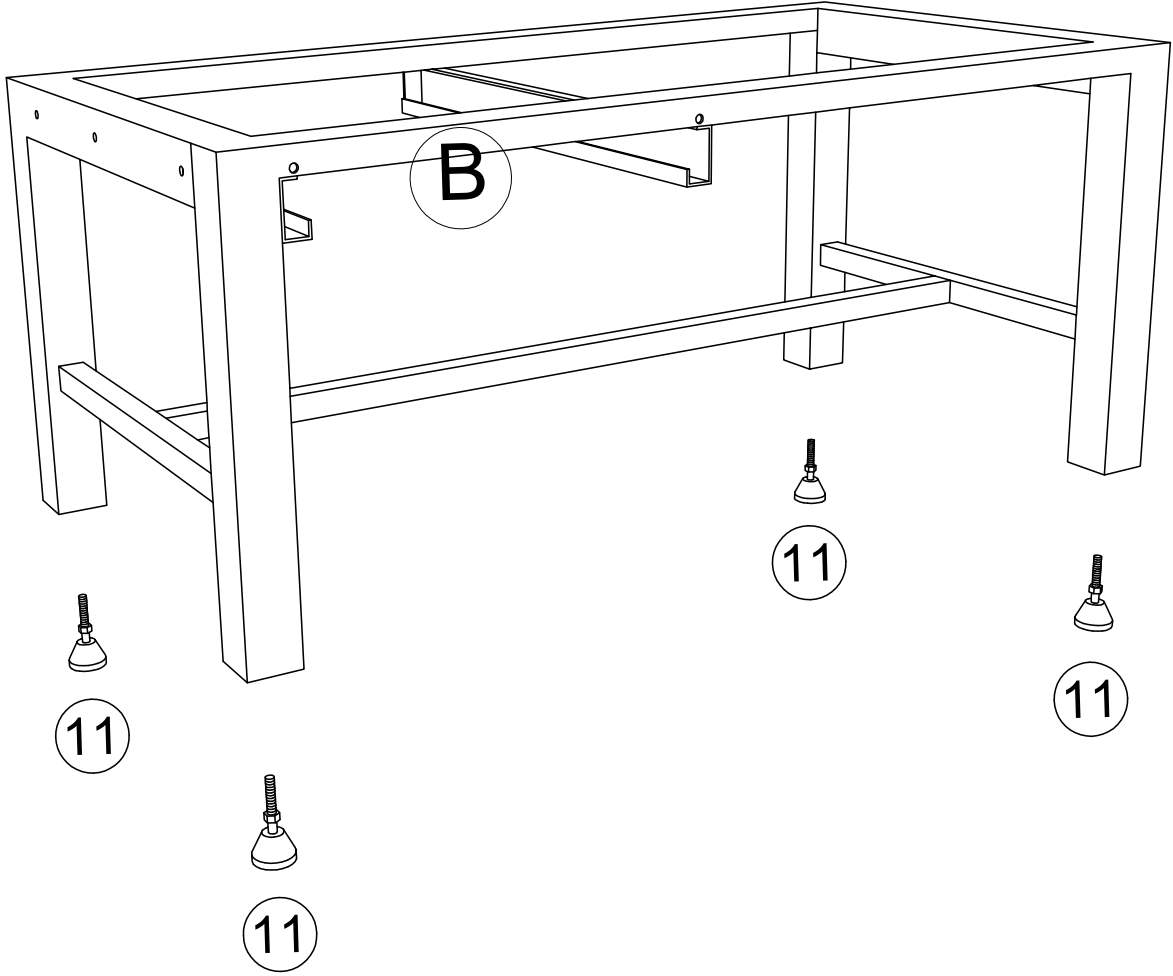

2

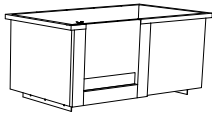

Ⓐ 1pc



Ⓢ 1pc

Please use the screwdriver to remove the screws from the wooden part at the bottom of part A. Besides, please ensure that the entrance on part A and the track on part B are positioned correctly, as shown in the picture.

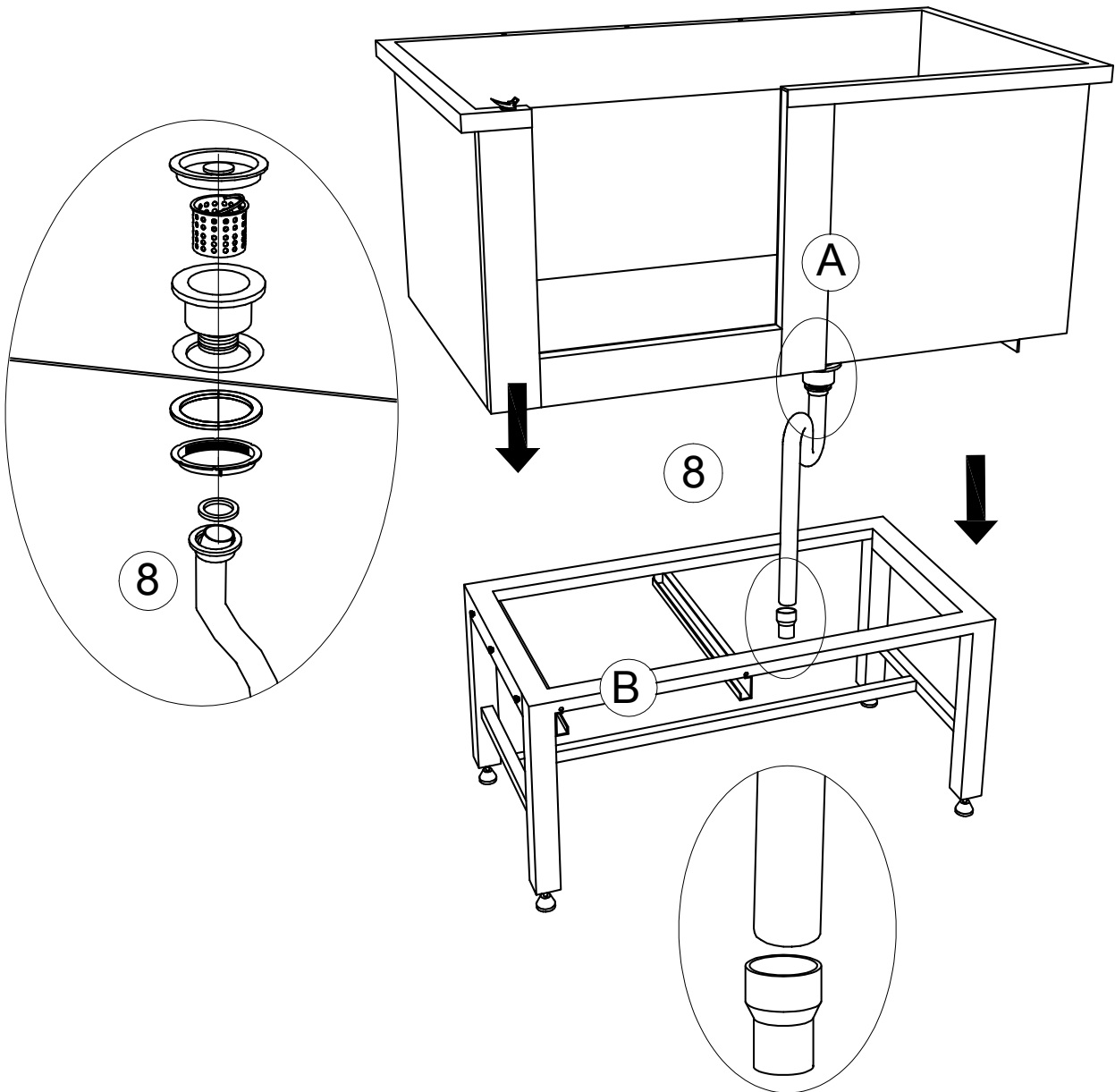

3

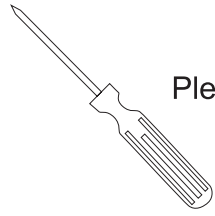
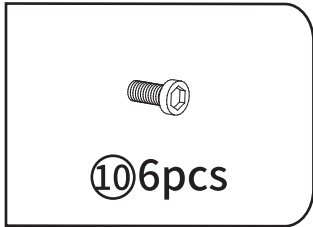

Please use a screwdriver to operate

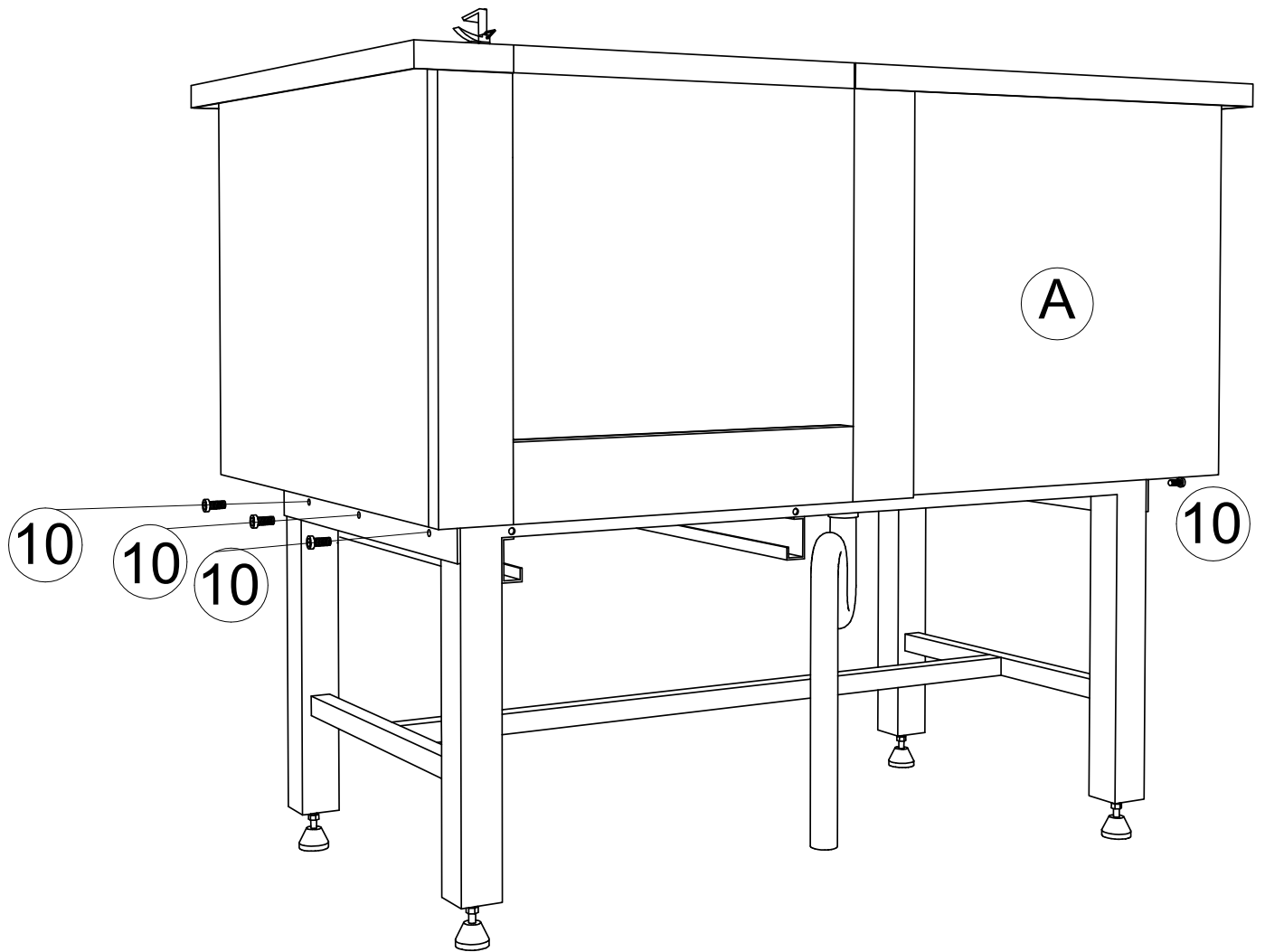

4

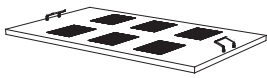

©1pc

C

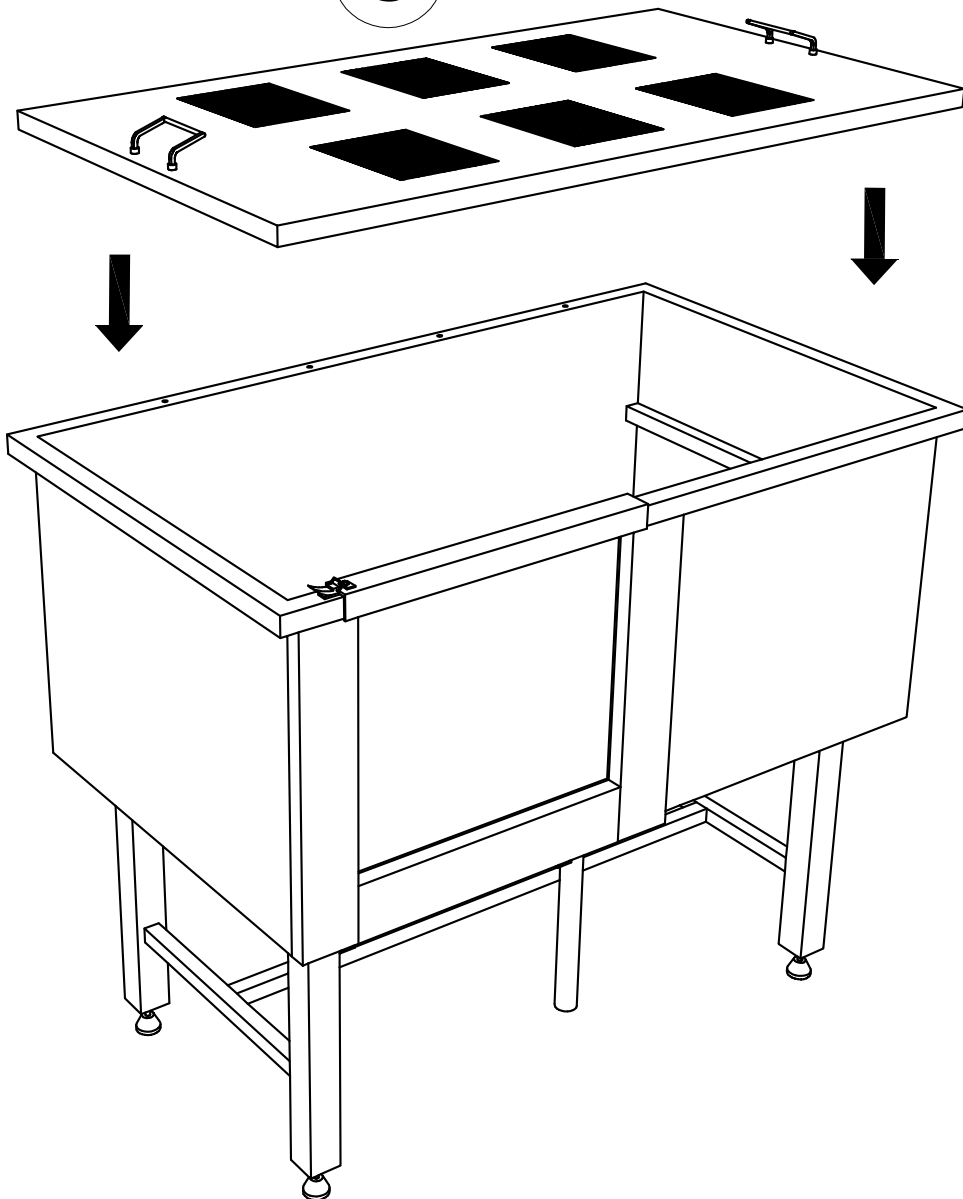

5



ⓔ1pc



ⓕ1pc



⑩6pcs

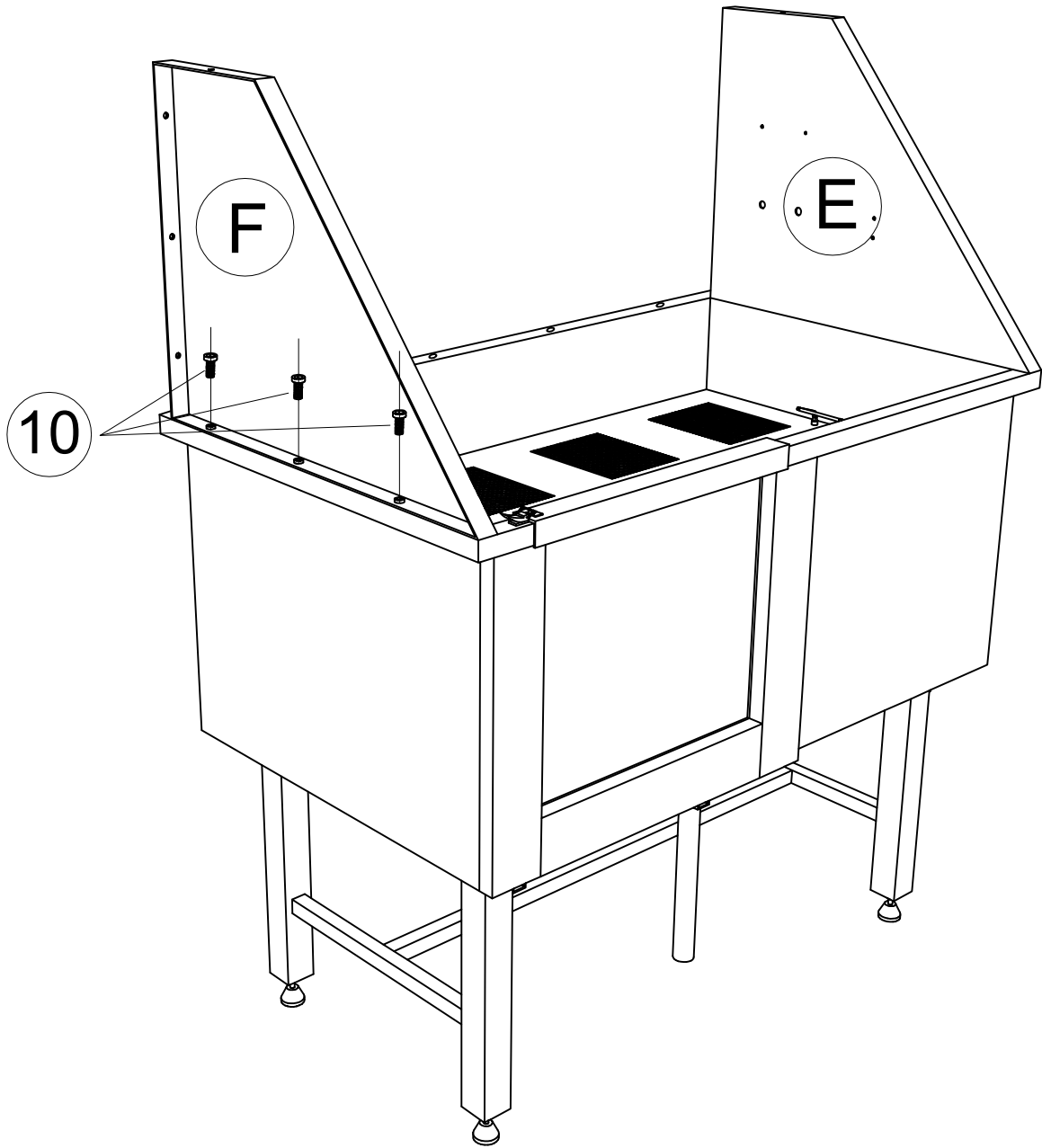

6



ⓐ1pc



⑩10pcs

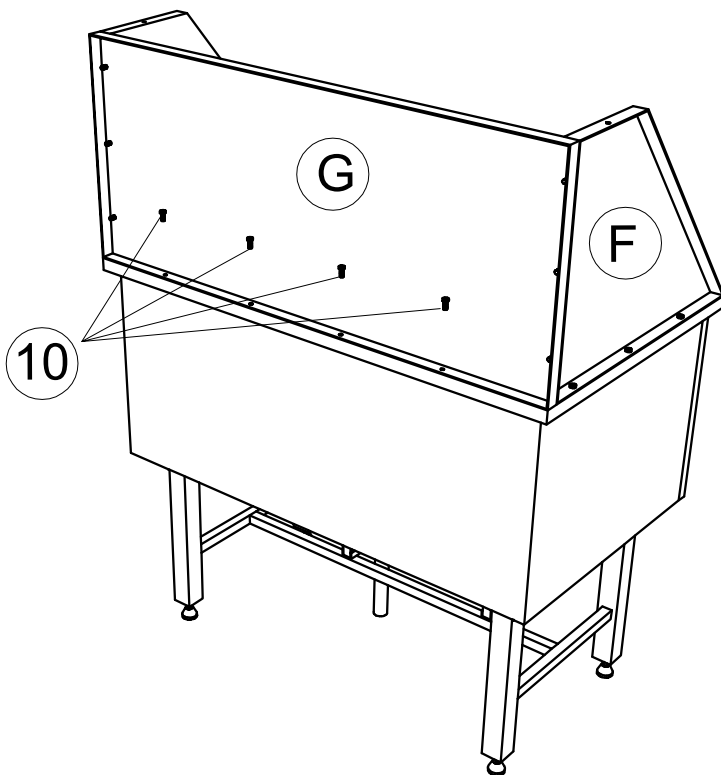
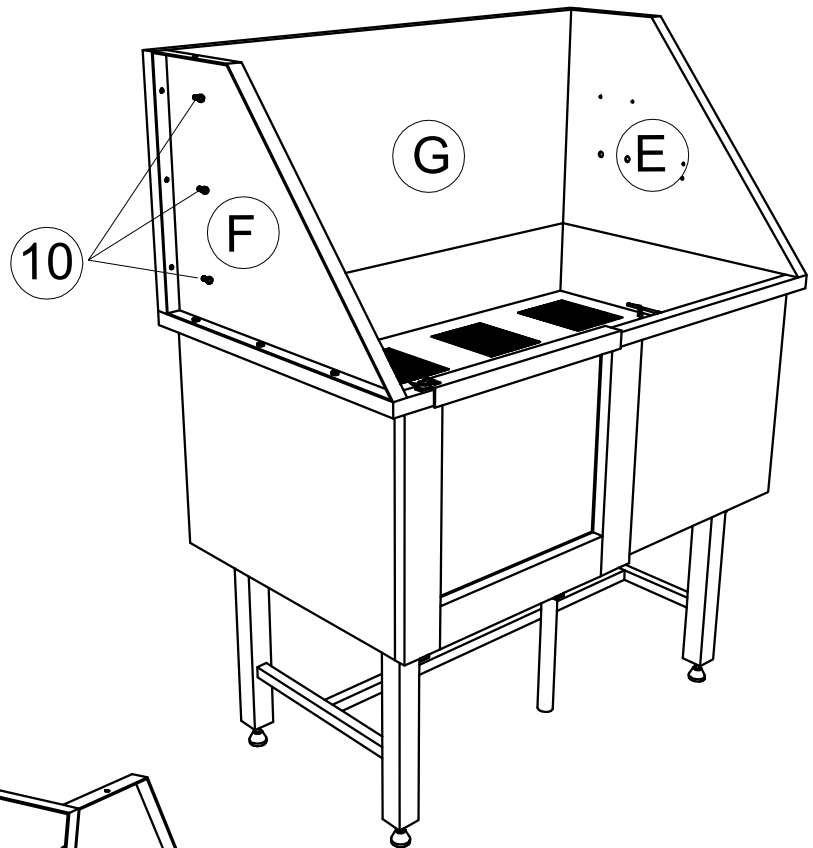

7

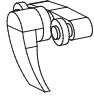

③ 1pc



⑤ 2pcs

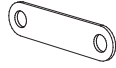

⑥ 1pc



⑱ 1pc





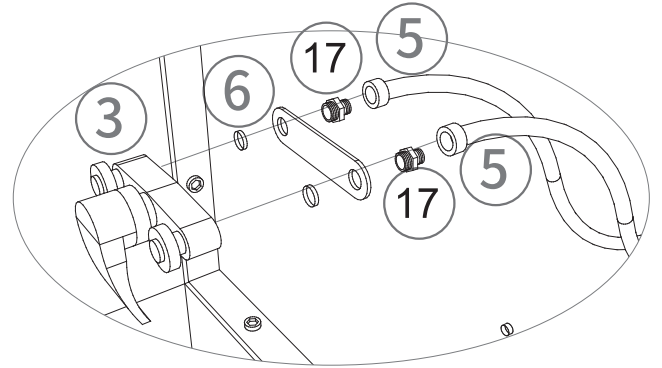

⑰ 2pcs

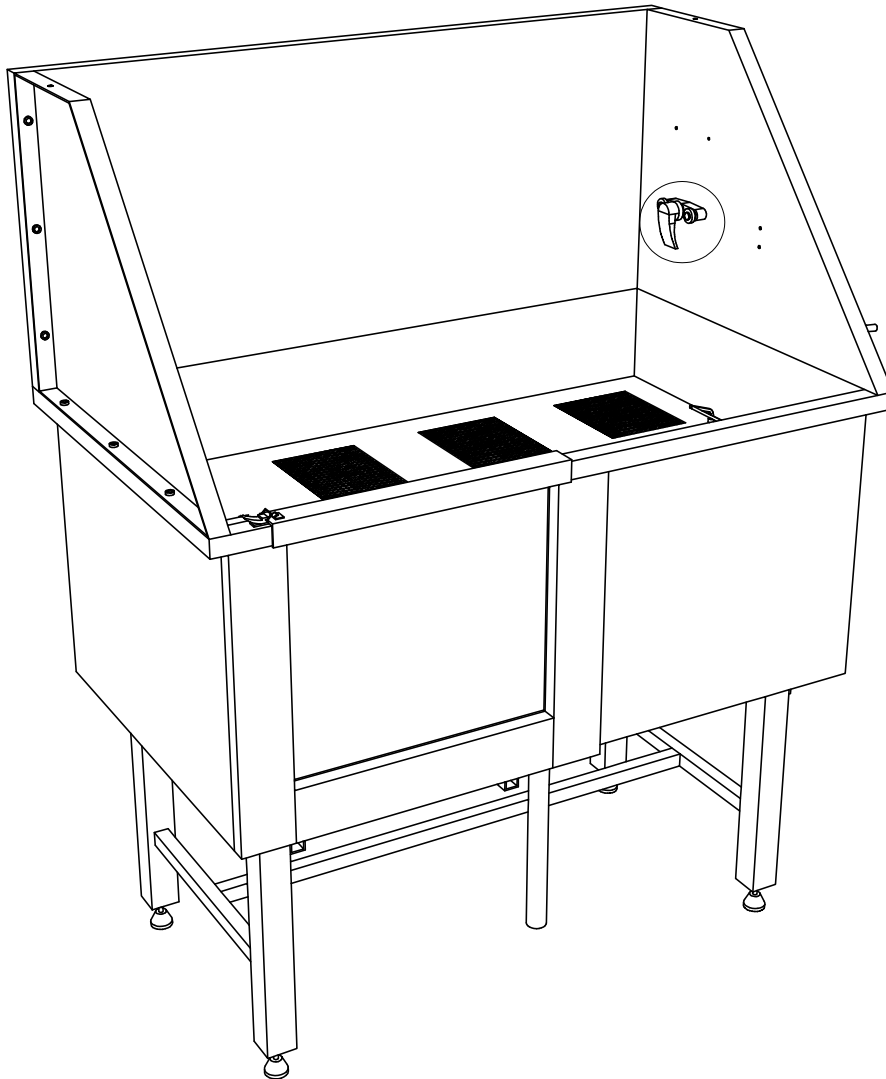

Please use waterproof tape for sealing at the pipe connections.



8

-  ② 1pc
-  ④ 1pc
-  ⑦ 1pc
-  ⑨ 2pcs



Please use waterproof tape for sealing at the pipe connections.

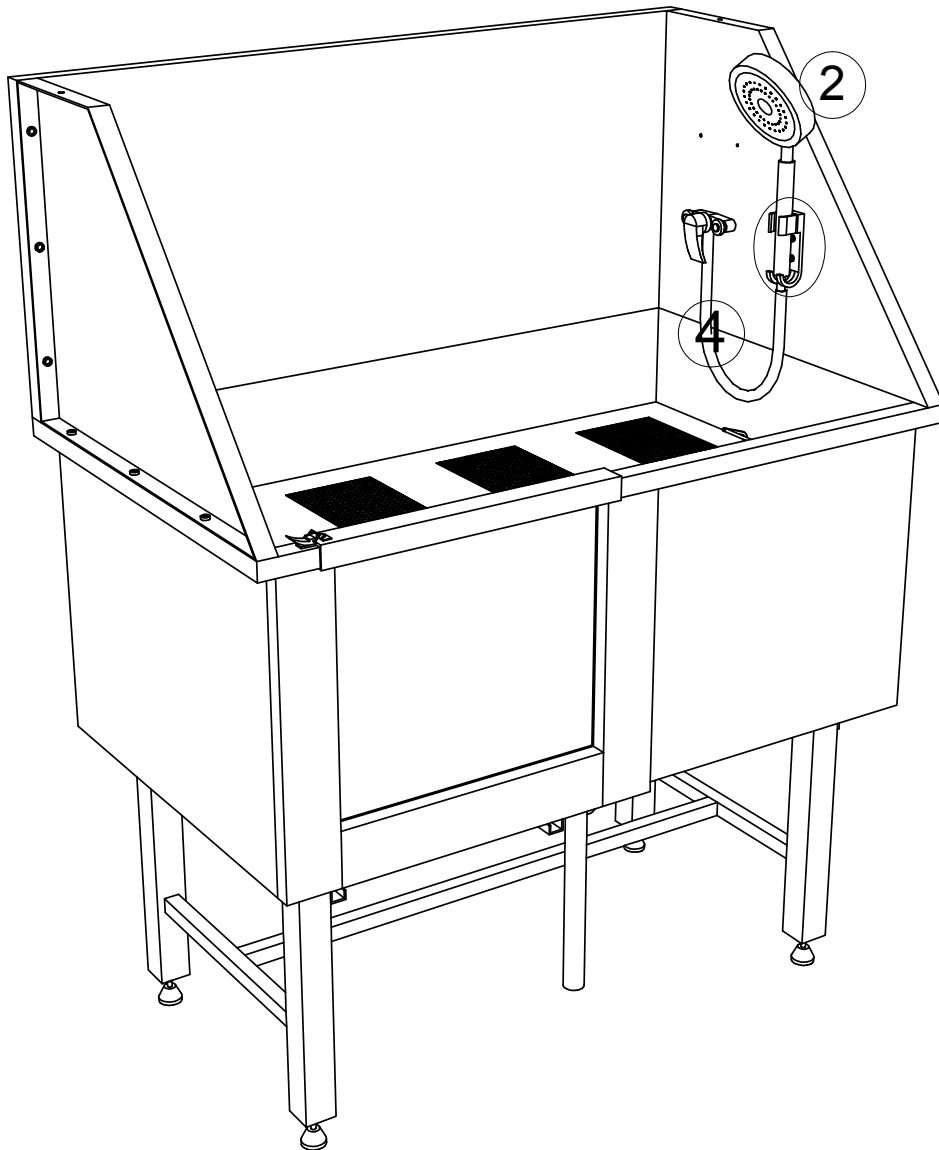
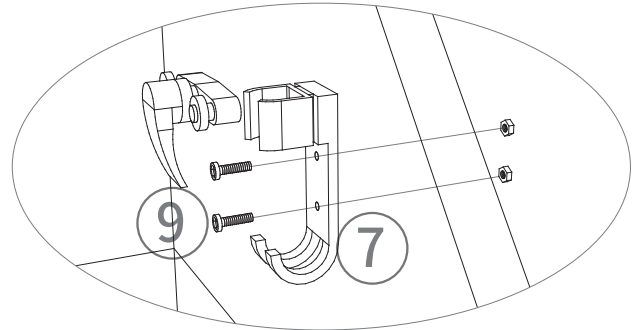

9

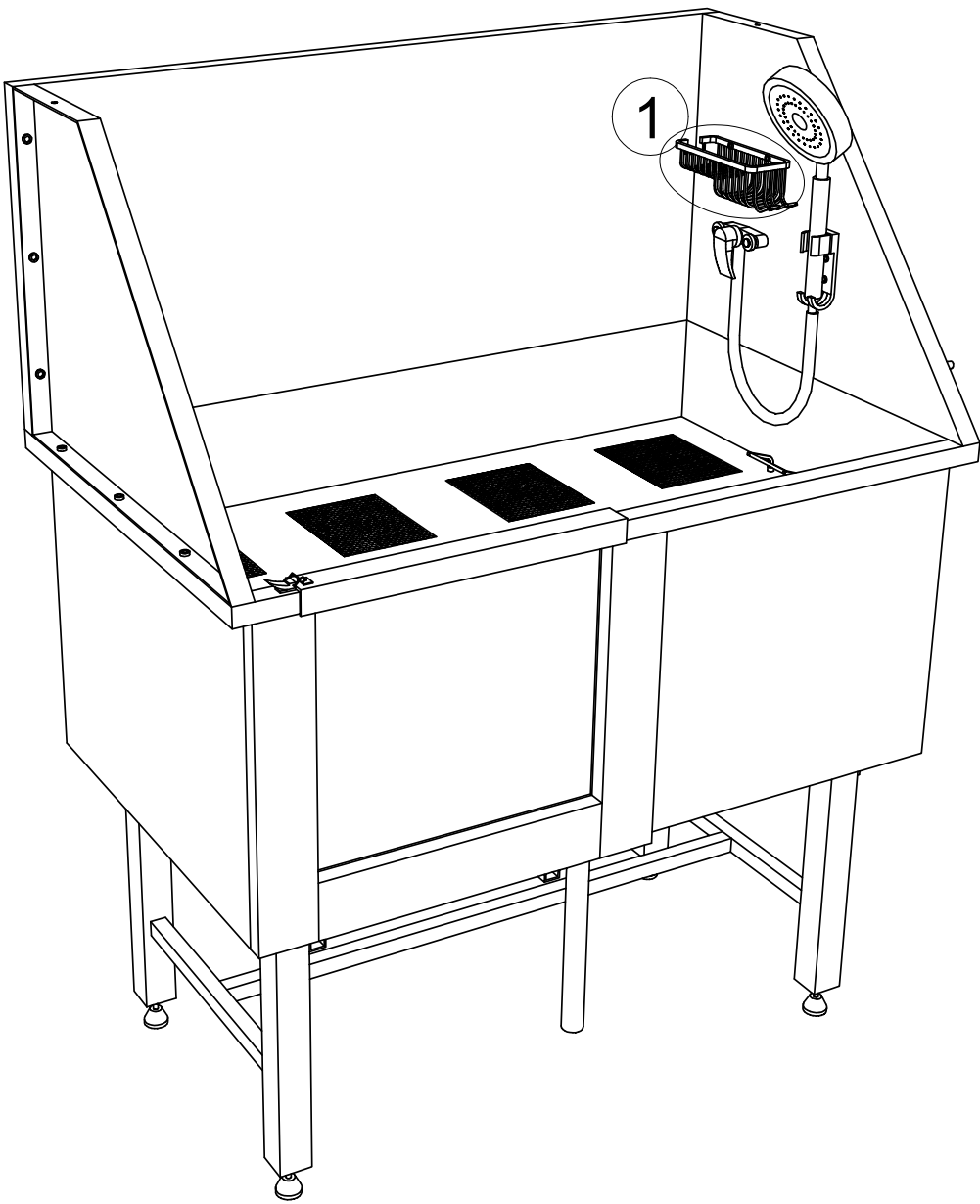
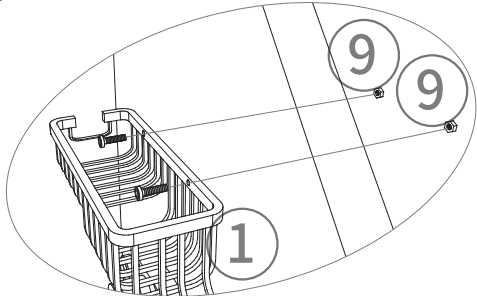
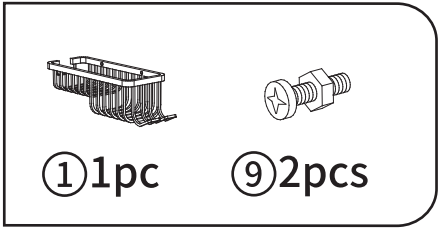

10



Ⓜ1pc



Ⓜ2pcs



Ⓜ2pcs



Ⓜ2pcs

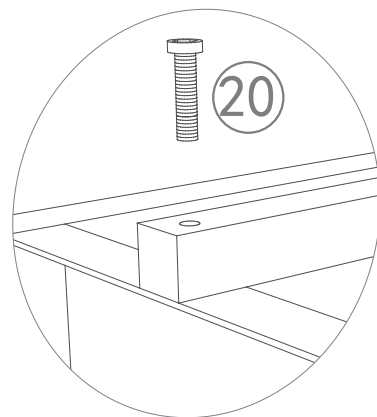
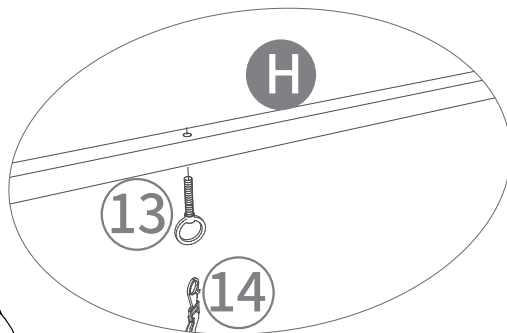
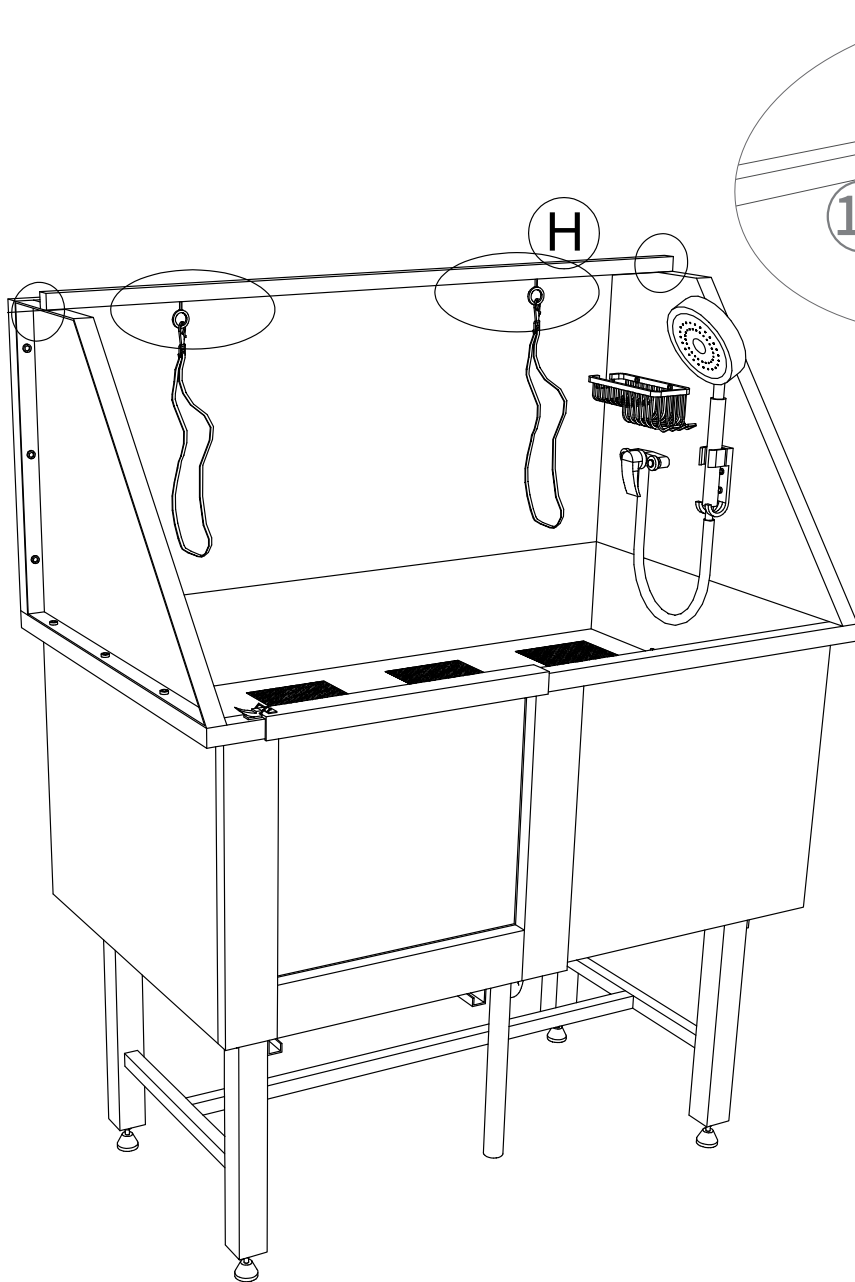

11



① 1pc



⑩ 2pcs



⑪ 2pcs



⑫ 2pcs

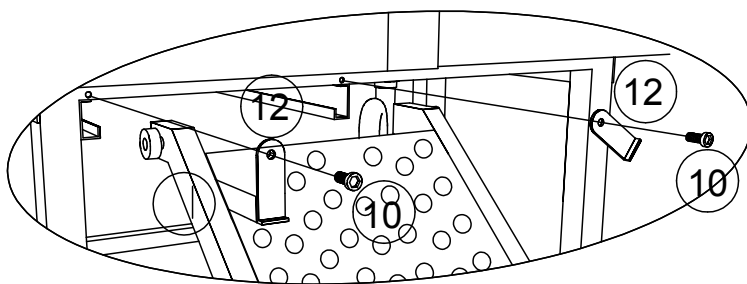
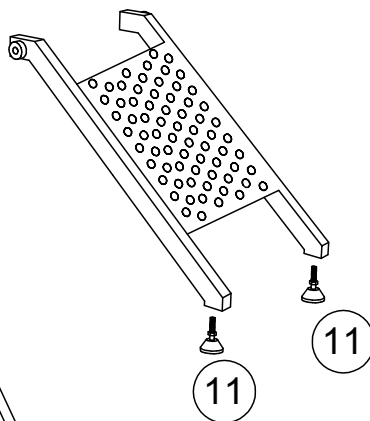
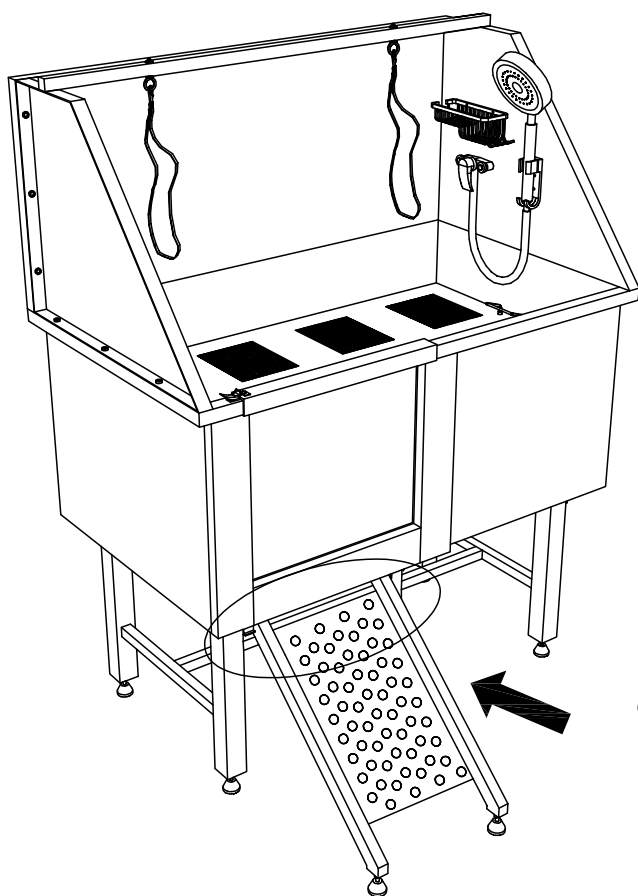

12

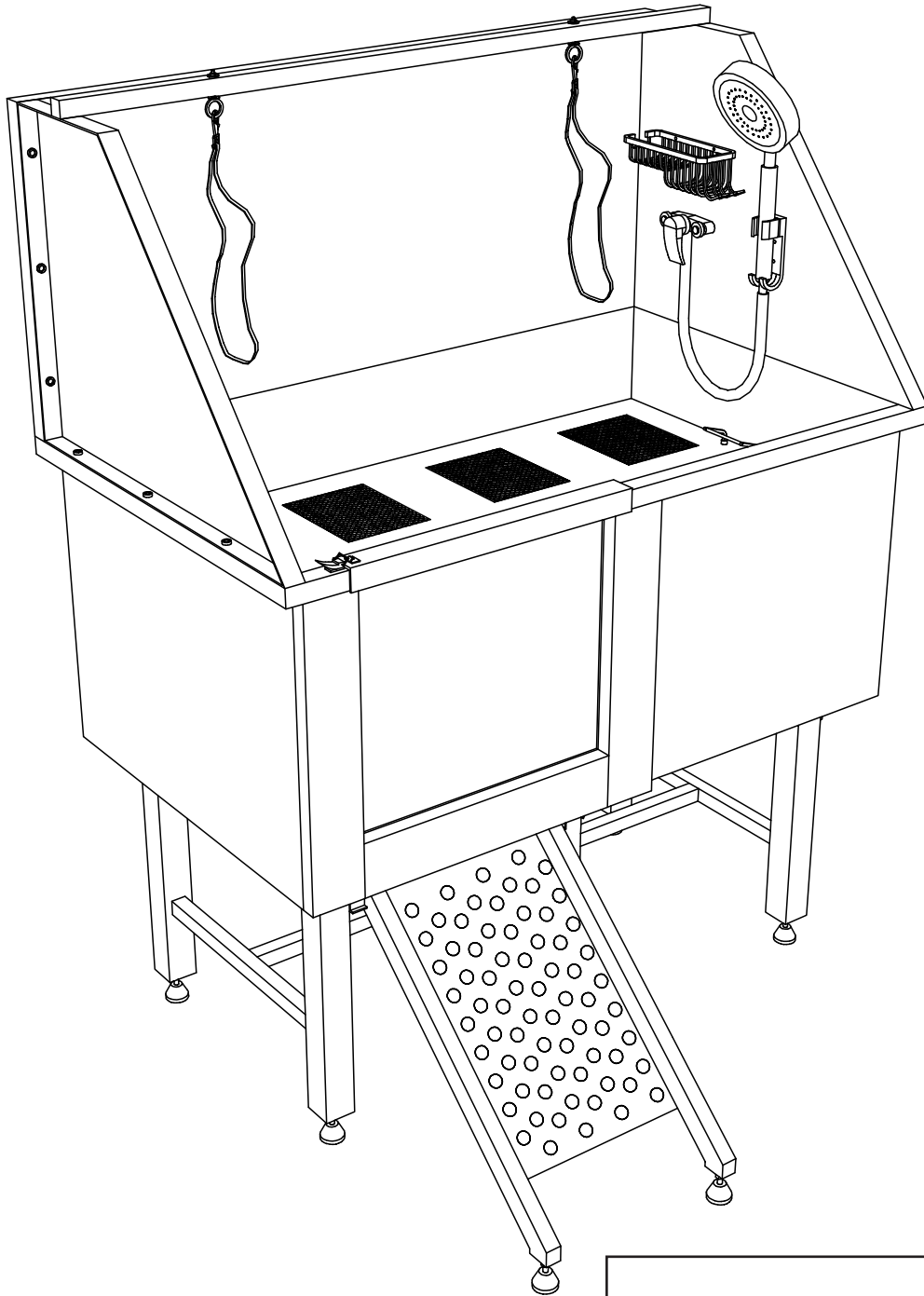

Installation Completed

We'd love to hear from you

Thank you for your recent purchase of our product. We hope that you are satisfied with both the product and the service provided. If not, please give our helpful customer service team a chance to improve your experience immediately. Our dedicated team members are more than willing to assist you.

Meanwhile, we also welcome you to post a Product User experience, so that others can benefit from your experience. As a growing company, we understand the value of time and therefore, we sincerely appreciate you taking the time to share your feedback.

We are constantly seeking ways to improve, and we thank you once again for your business, support, and feedback.

Warm Regards Customer Support

For Replacement Parts or Technical Assistance, please feel free to contact us through the platform you purchase, and provide following information:

Order number

Part number and quantity