

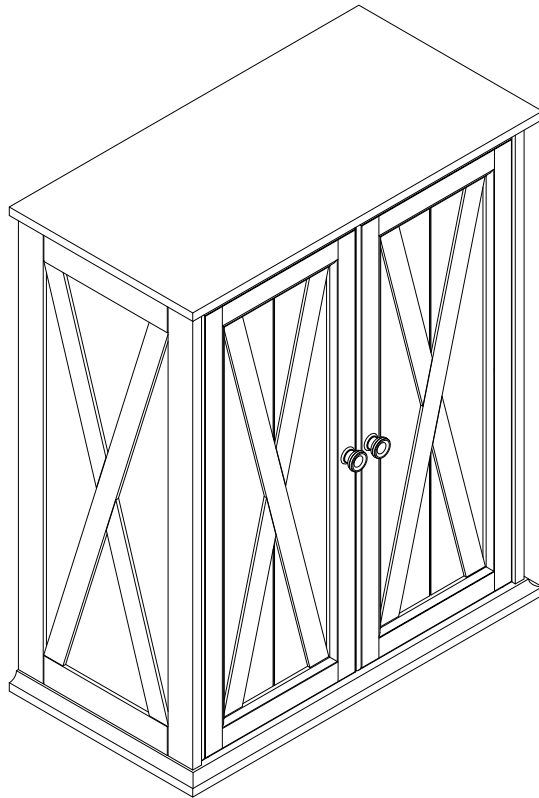

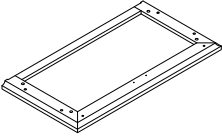

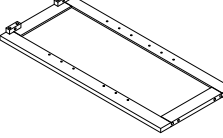

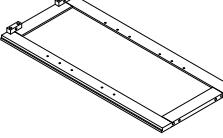

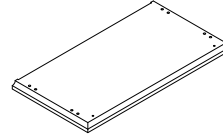
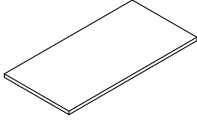
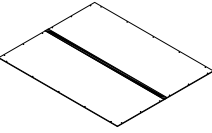
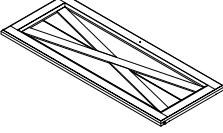
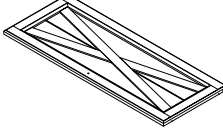





Stackable Pantry

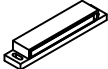

PART LIST

<p>A</p> 	<p>B</p> 	<p>C</p> 	<p>D</p> 	<p>E</p> 
<p>Top Panel 1 PC</p>	<p>Left Panel 1 PC</p>	<p>Right Panel 1 PC</p>	<p>Bottom Panel 1 PC</p>	<p>Adjustable Shelf 2 PCS</p>
<p>F</p> 	<p>G</p> 	<p>H</p> 		
<p>Back Panel 1 PC</p>	<p>Left Door Panel 1 PC</p>	<p>Right Door Panel 1 PC</p>		

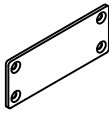
HARDWARE LIST

 $\phi 1/4" \times 1-1/4"$	 $\phi 5/32 \times 25 \text{mm}$	 $\phi 3 \times 14 \text{mm}$	 $\phi 3 \times 14 \text{mm}$	 $\phi 3.5 \times 15 \text{mm}$
Bolt 8 PCS	Round Head Bolt 2 PCS	Screw 22 PCS (Extra 1)	Round Head Screw 2 PCS	Long Screw 8 PCS
 $\phi 1/4"$	 $\phi 1/4" \times 16 \text{mm}$			
Spring Washer 8 PCS	Flat Washer 8 PCS	Knob 2 PCS	Shelf Holder 8 PCS (Extra 1)	Magnet 1 PC
 $\phi 8 \times 30 \text{mm}$				
Wood Dowel 8 PCS	Connecting Bar 2 PCS	Allen Wrench 1 PC	Safety Strap Kit 1 SET	

ADDITIONAL TOOLS (Not Provided)

Note: It is not recommended to use power tools during assembly.

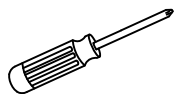

Phillips Head Screwdriver

Note: Wood dowels are intended for alignment. Additional clearance between wood dowel and pre-drilled hole is intentional for ease of assembly.

Step 1. Attach knobs (parts #8) to door panels (parts G & H) using round head bolts (part #2) and phillips head screwdriver. Attach magnet (part #10) to top panel (part A) using round head screws (part #4) and phillips head screwdriver.

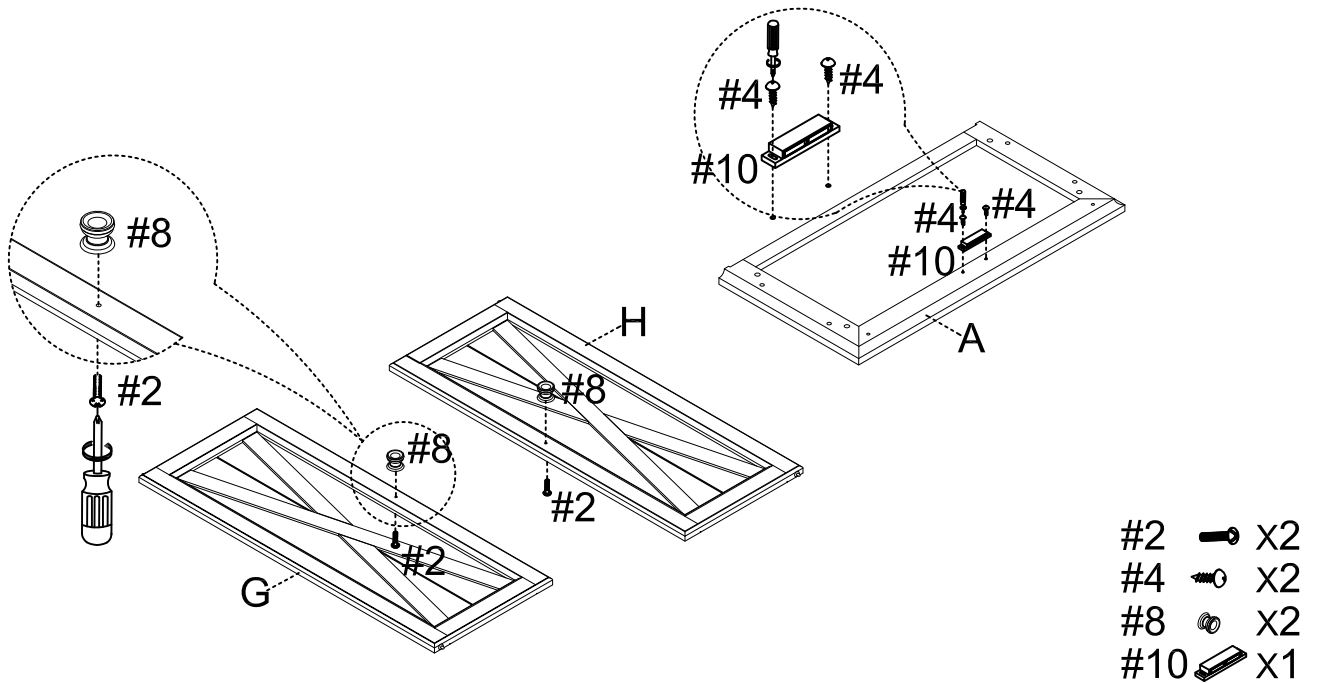

Step 2. Attach bottom panel (part D) to panels (parts B & C) using wood dowels (part #11), bolts (part #1), spring washers (part #6), flat washers (part #7) and allen wrench (part #13).

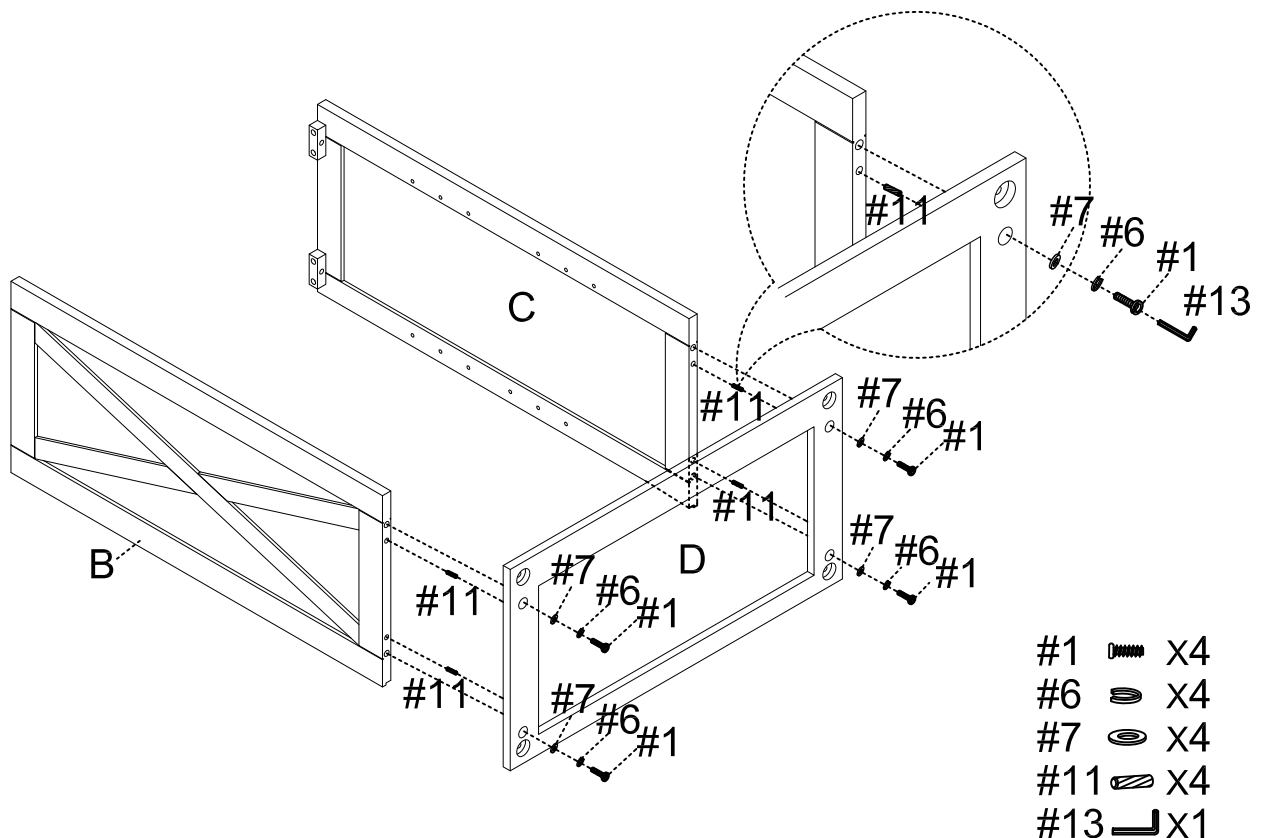

Step 3. Attach top panel (part A) to panels (parts B & C) using wood dowels (part #11), bolts (part #1), spring washers (part #6), flat washers (part #7) and allen wrench (part #13).

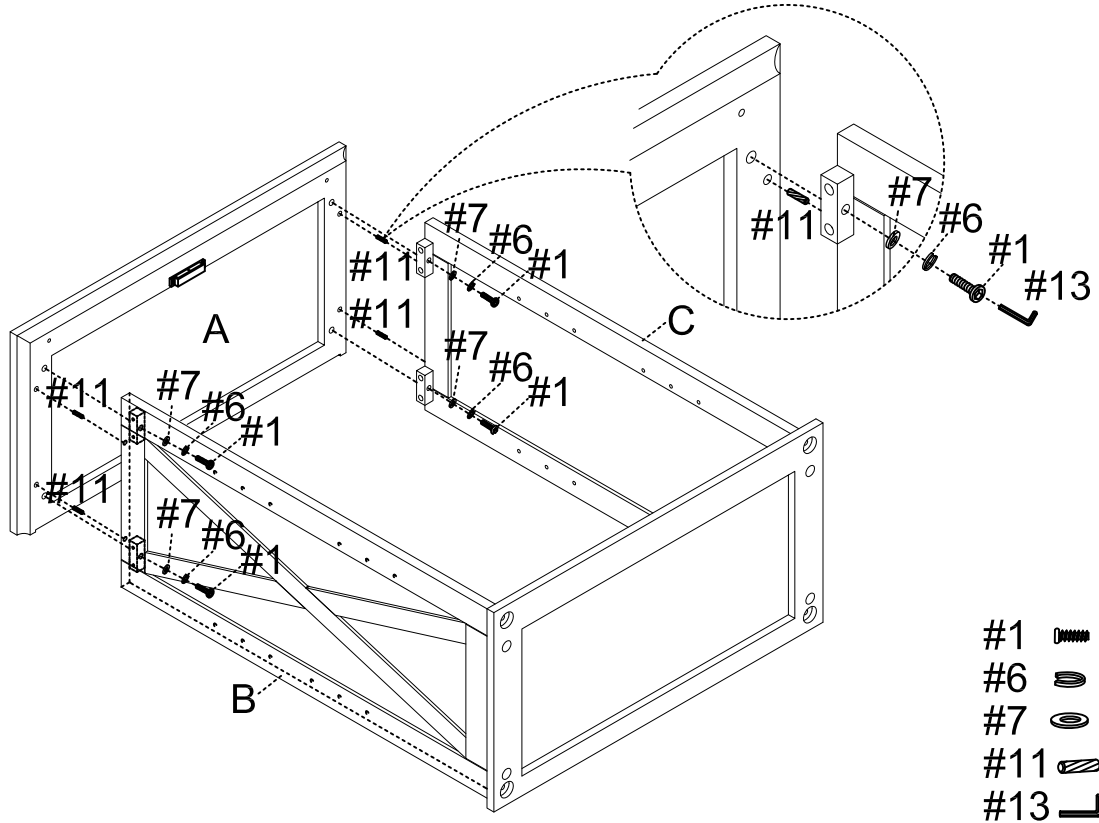

Step 4. Attach back panel (part F) to assembled unit (parts A, B, C & D) using screws (part #3) and phillips head screwdriver.

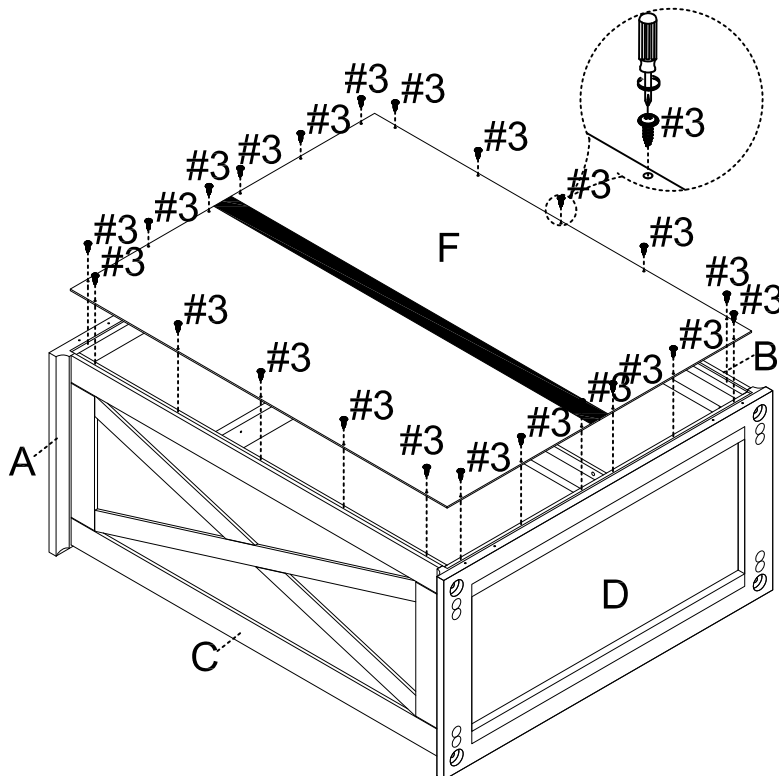

#3 X22

Step 5. Carefully turn unit upright. Place shelf holders (part #9) into desired position and slide adjustable shelves (part E) into place.

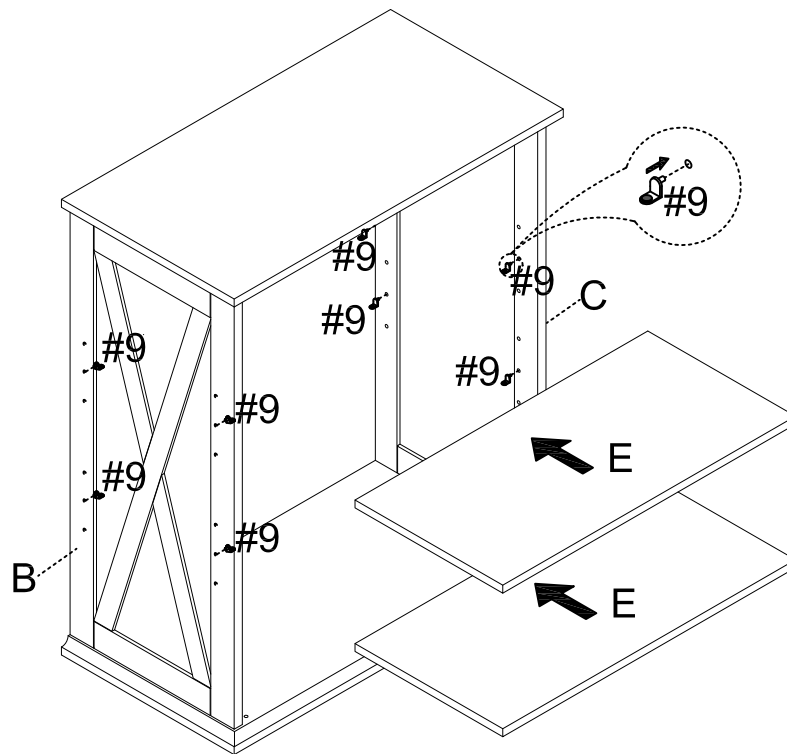

#9  x 8

Step 6. Attach door panels (parts G & H) by placing bottom pin hinge (pre-installed in door) in the pre-drilled hole of bottom panel (part D). Then depress the top spring-loaded pin hinge so it can be placed in the pre-drilled hole of top panel (part A).

Note: Be sure top and bottom pin hinges are fully extended to secure doors in place.

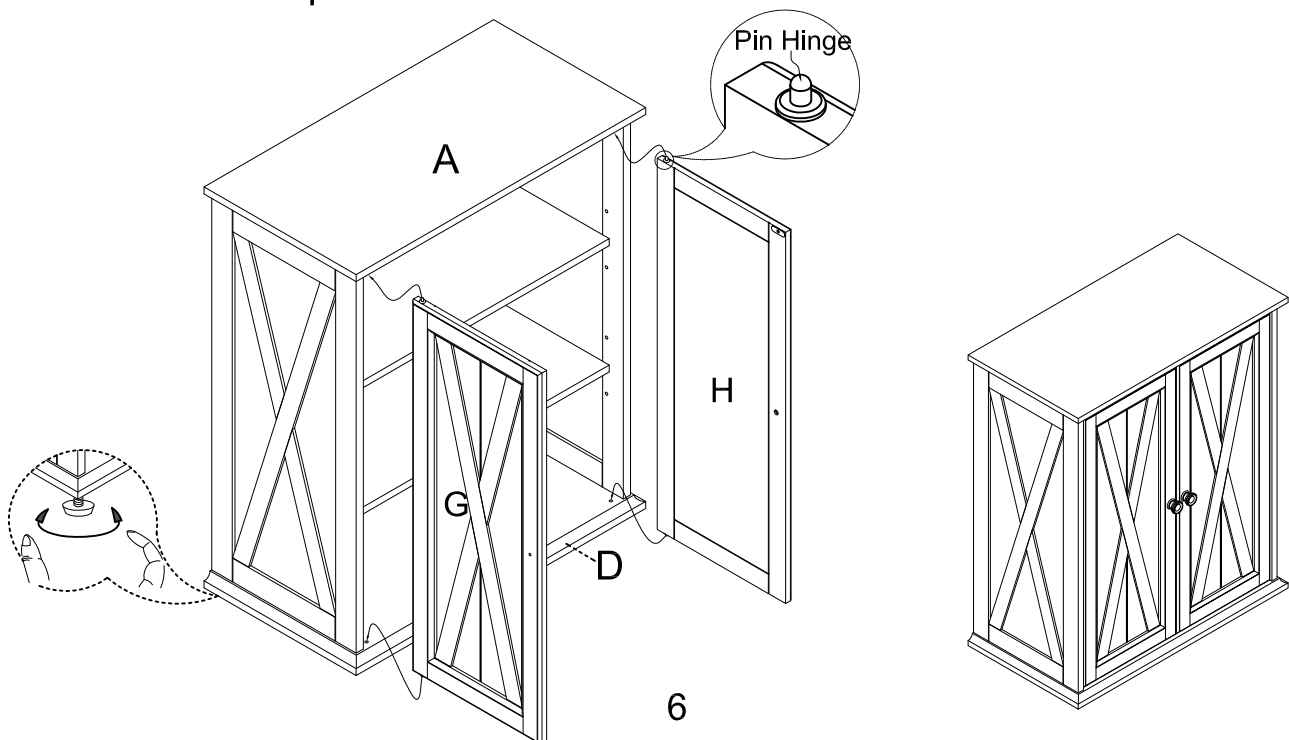

Step 7. Overlay the cabinets together.

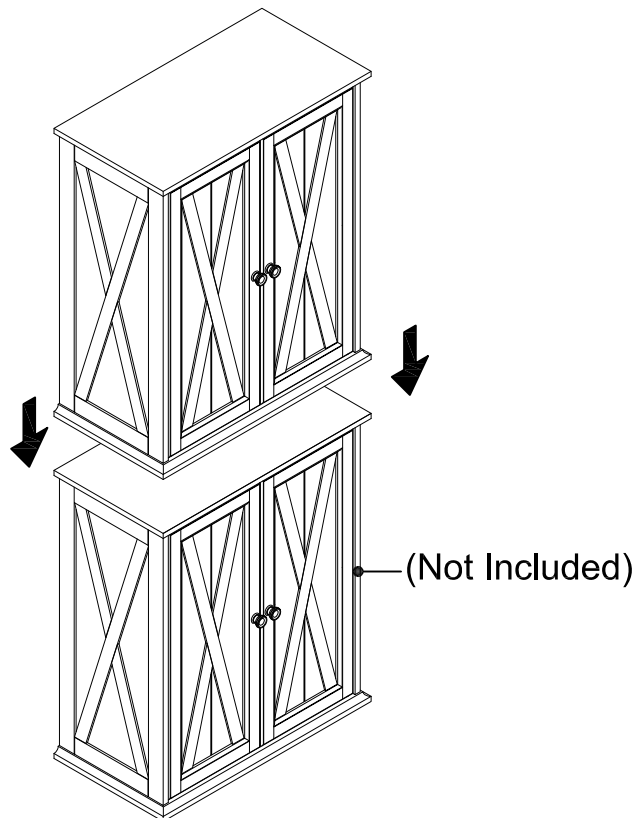







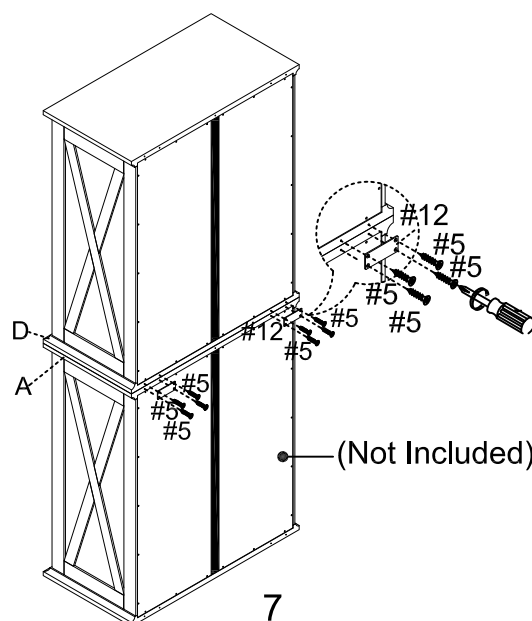

Step 8. Attach connecting bars (part #12) to bottom panel (part D) and top panel (part A) using long screws (part #5) and phillips head screwdriver.

Important: Safety strap kit (part #14) must be installed to prevent tipping, damage and/or injury.

NOTE: It is important to adjust levelers once fully assembled and upright. Extend adjustable leveler until it's firmly in contact with the floor. If relocating, adjust leveler as needed until it's firmly in contact with the floor in new location.



#5  x8
#12  x2

#14	A	B	C	D	E
					
Safety Strap Kit 1 SET	Wall Anchor 1 PC	Bracket 2 PCS	5/8"x ϕ 3xD8 Short Screw 1 PC	1-1/2"x ϕ 4xD8 Long Screw 1 PC	Safety Wall Strap 1 PC

SAFETY WALL STRAP INSTALLATION

Note: It is highly recommended to install this safety strap kit to prevent tipping, damage and/or injury.

1. Insert short screw (C) and safety wall strap (E) through bracket (B) and attach to top panel (part A) using phillips head screwdriver.
2. Drill a 11/32" hole where you want to secure the unit. The drilled hole will be at the same height as the hole in top panel (part A) where bracket (B) is attached. Tap wall anchor (A) into the hole.
3. Insert long screw (D) and safety wall strap (E) through bracket (B) into wall anchor (A) using phillips head screwdriver.

Note: This item is not intended for clothing storage use.

