

ELD75LS

Assembly Instructions

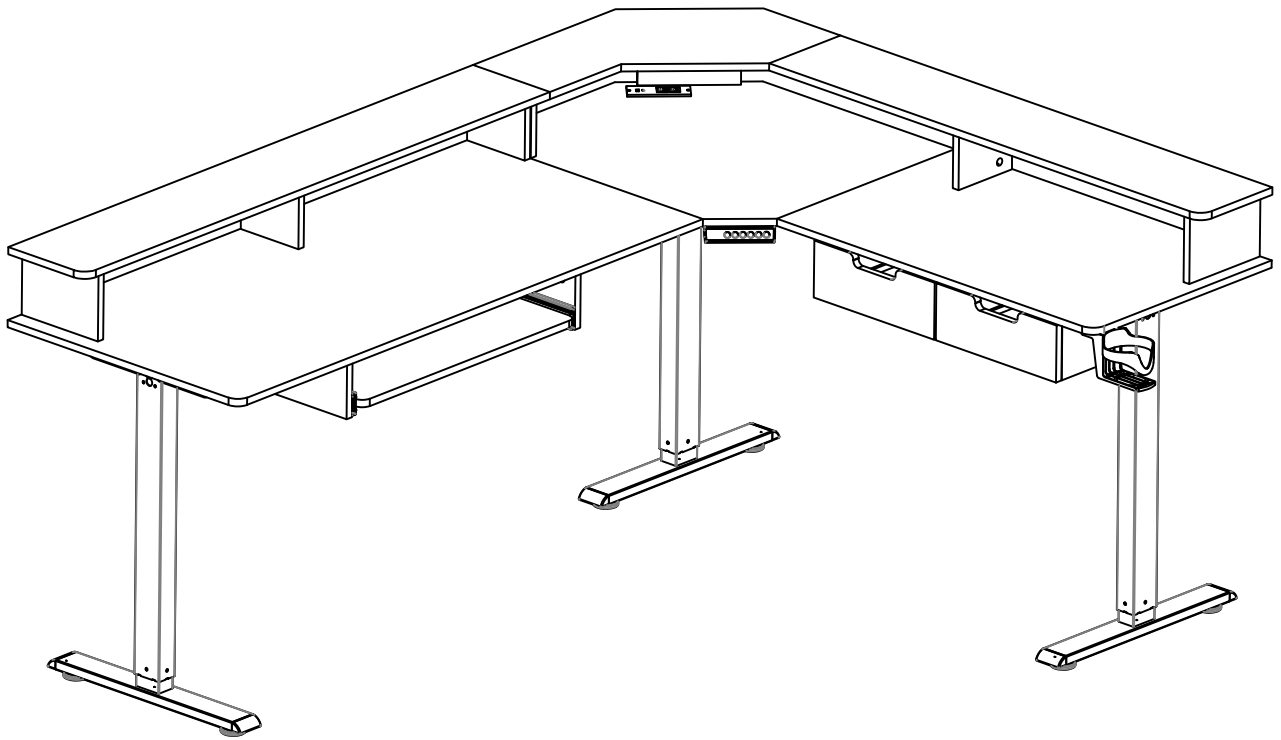

Date 2024-10-28 Rev.01-A

General Assembly Guidelines

- I. Ensure that all parts and hardware are available before beginning assembly.
- II. Follow each step carefully to ensure the proper assembly of this product.
- III. Two people are recommended for ease in the assembly of this product.
- IV. A Phillips head screwdriver is required for the assembly of this product .

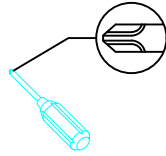

- V. The provided glue is to secure wood dowels in place . When first inserting dowels , locate the appropriate hole for the dowel , place a small amount of glue in the hole and insert the dowel . Wipe away excess glue immediately.

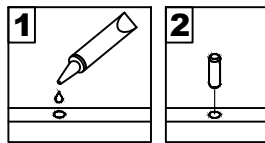

In future assembly steps when dowels are necessary to attach assembly parts together , place a small amount of glue on the end of the dowel before attaching parts together . Wipe away excess glue immediately.

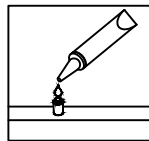

VI HOW THE KNOCK DOWN (KD) ASSEMBLY SYSTEM WORKS

- 1.Screw the Cam Bolt into the pre-drilled hole on the panel. Make sure Cam Bolt goes into the pre-drilled hole on the end of panel for Cam Lock.
- 2.Insert the Cam Lock into the pre-drilled large hole on the panel. Make sure the arrow on the face of Cam Lock points towards Cam Bolt.
- 3.Take a Phillips screwdriver and rotate the Cam Lock clockwise to lock the Cam Bolt.
- 4.Use the sticker to conceal the Cam.

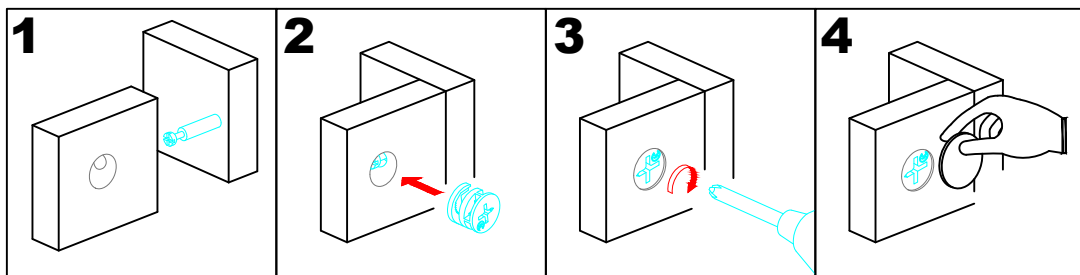

- VII. Power tools should not be used to assemble this product .

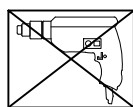





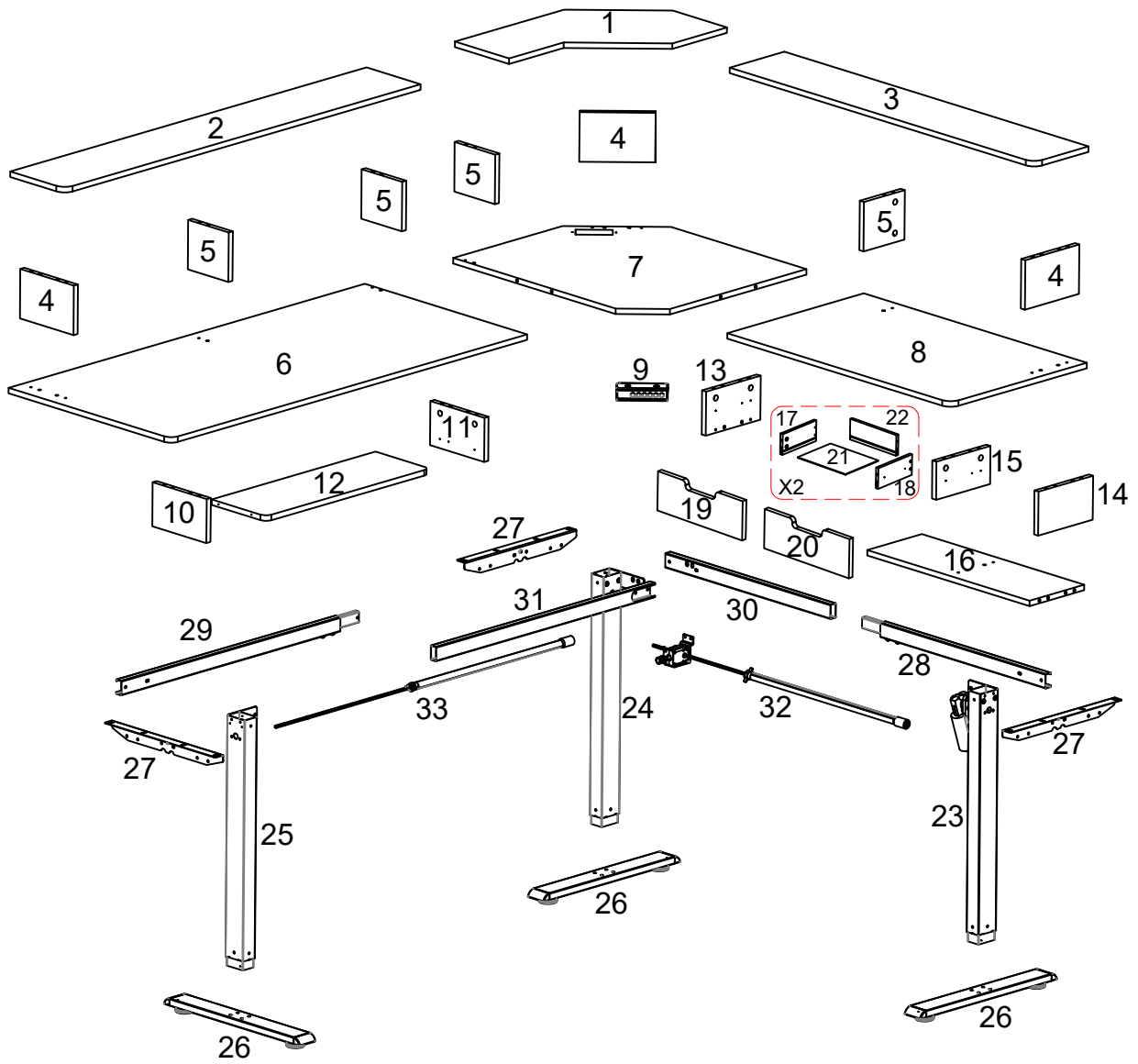







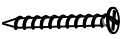









⚠ WARNING **INGESTION HAZARD• DEATH** or serious injury can occur if ingested • A swallowed button cell or coin battery can cause **Internal Chemical Burns** in as little as **2 hours**.
• **KEEP** new and used batteries **OUT OF REACH OF CHILDREN** • **Seek immediate medical attention** if a battery is suspected to be swallowed or inserted inside any part of the body.

Parts List



Hardware List

A		Ø8*30mm	Wooden dowel	40 pcs
B		Ø6*35mm	Cam bolt	42 pcs
C			Cam lock	34 pcs
D			Cam lock(Small)	8 pcs
E		Ø30mm	Sticker	42 pcs
F		Ø4*38mm	Screw	10 pcs
G		Ø4*12mm	Screw	32 pcs
H			Clip	15set
I		8"	Drawer slider	6 pcs
J			Cup holder	1 pc
K			Adapter	1 pc
L			Connector cable	1 pc
M			USB Interface	1 pc
N			Cable clamp	4 pcs
O		Ø5*16mm	Screw	2 pcs
P		114*50mm	Metal plate	5 pcs
Q		Ø6*12mm	Bolt	54pcs
R		Ø6*35mm	Bolt	12 pcs
S			Hooks	2 pcs
T		M4	Hexagon socket key	1 pc
U			Led strip light (Included plastic bag)	1 set
V			Glue tube	1 pc
W				1 pc
X			Screw	2 pc

Step 1

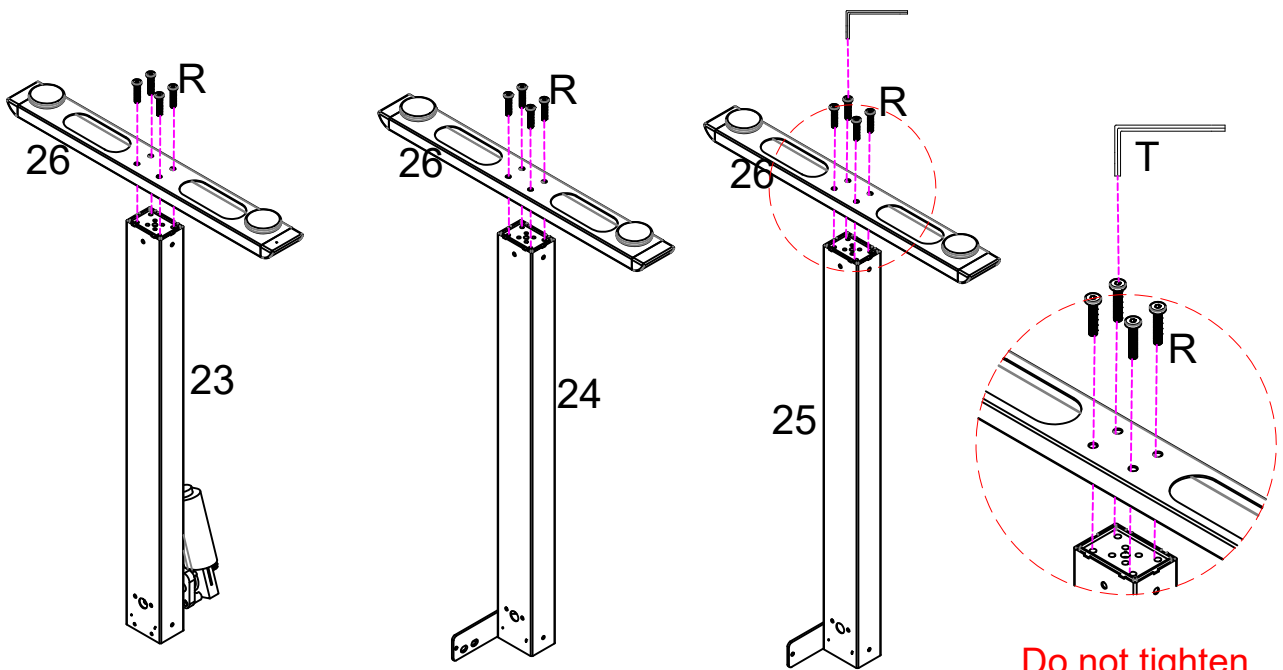

Step 2

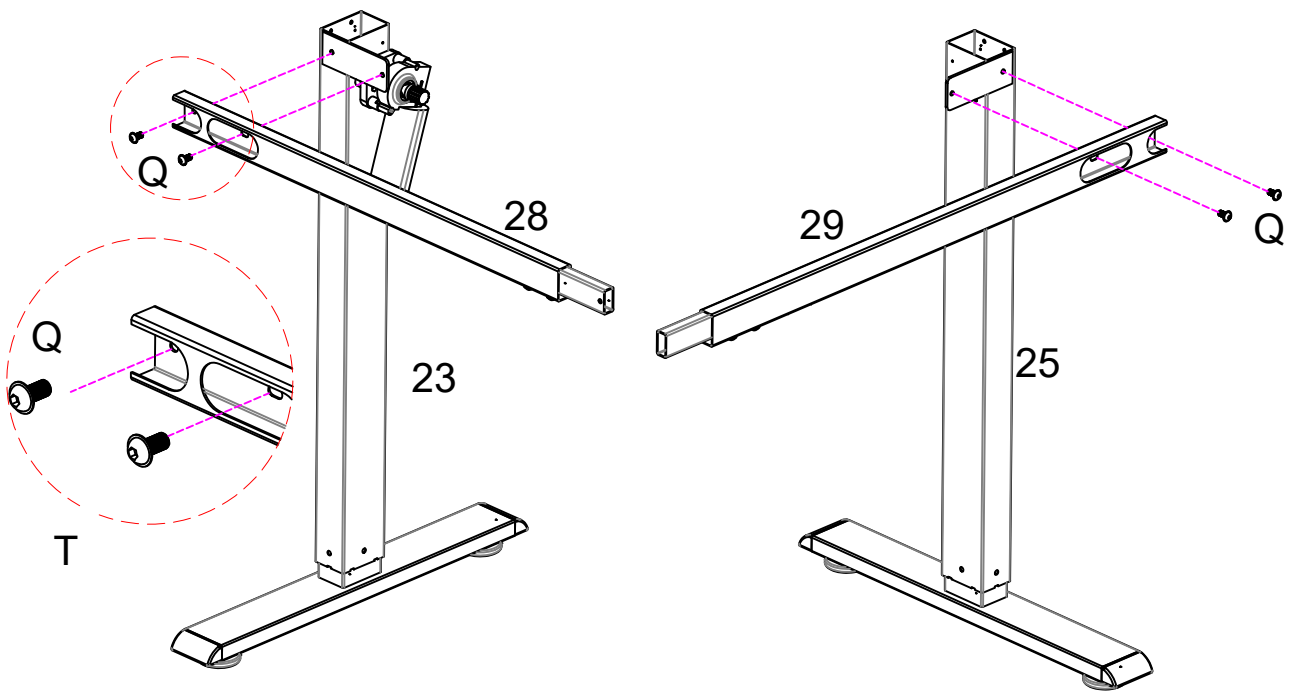

Step 3

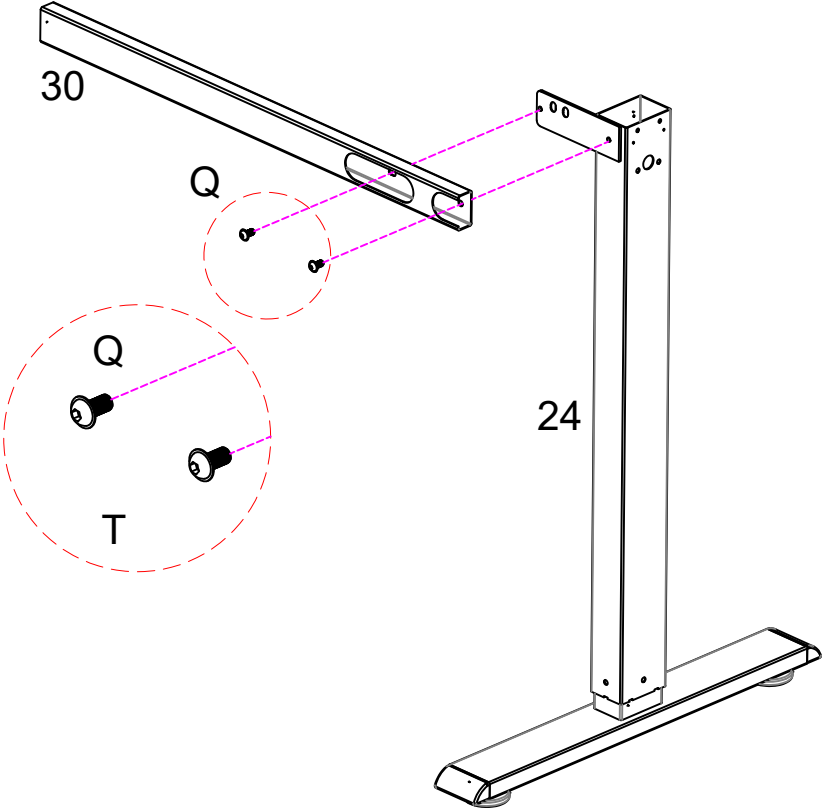

Step 4

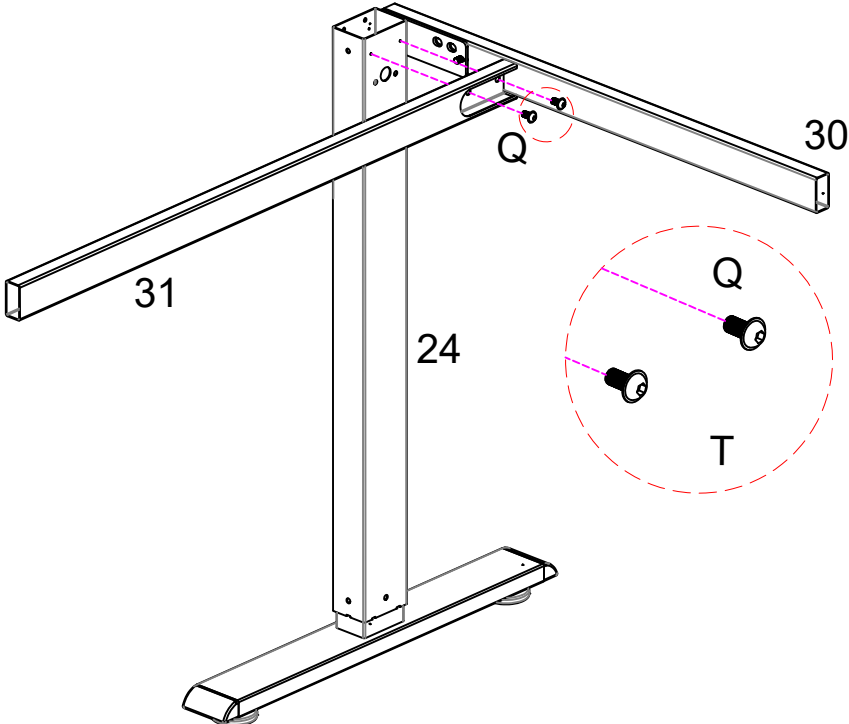

Step 5

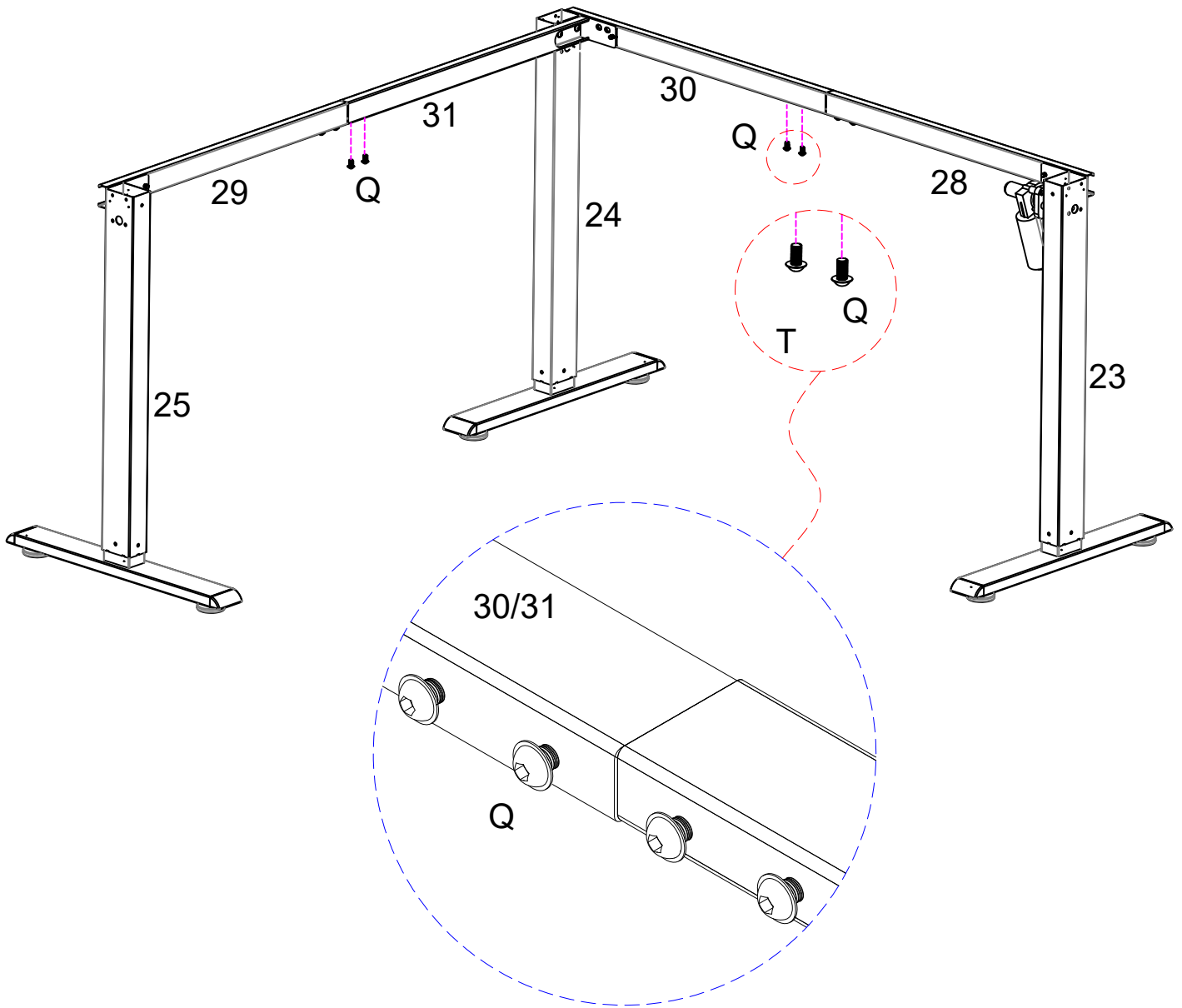

After tightening the bolt (Q), as shown

Step 6

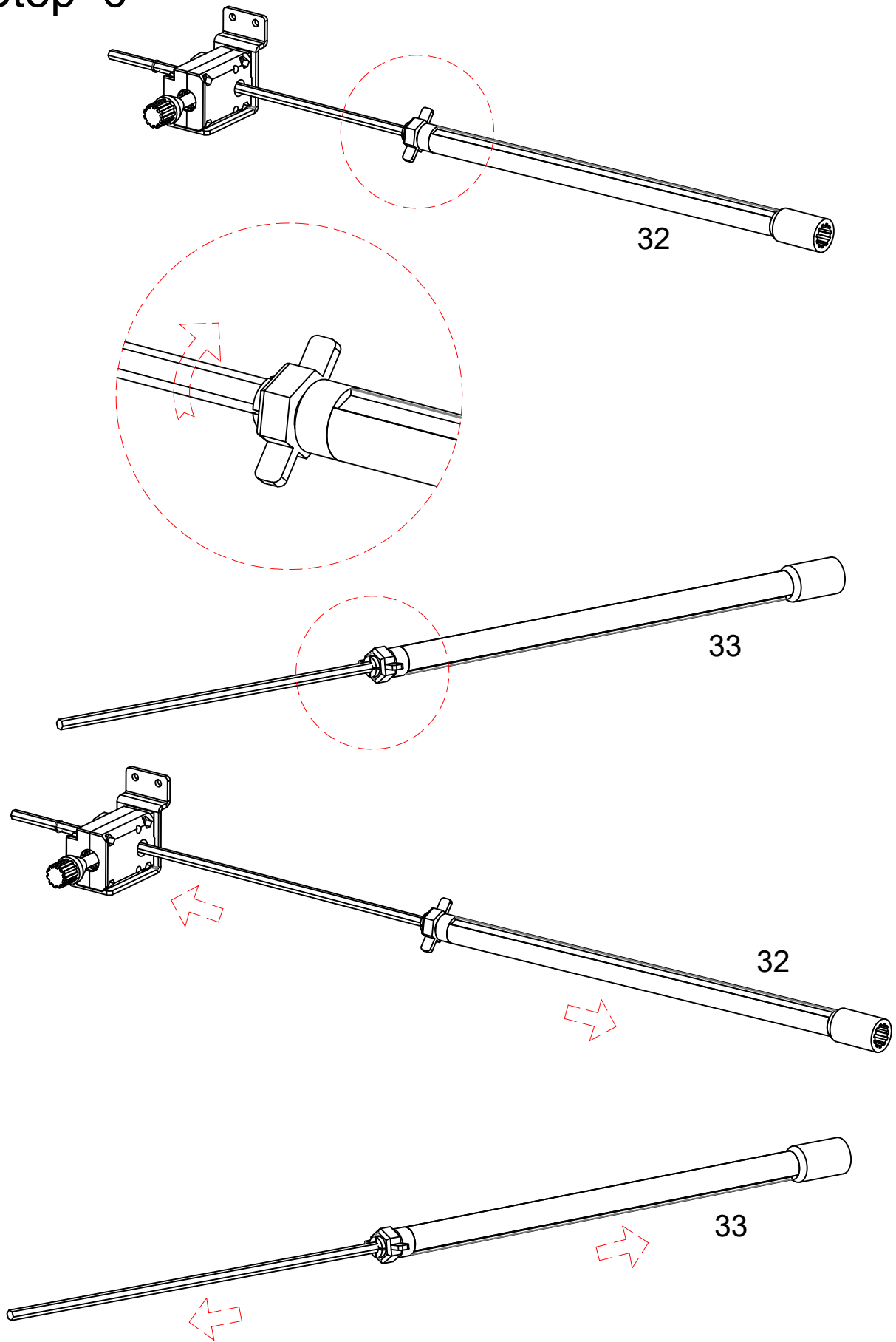

Loosen the plastic lock by rotating it and pull-out the shaft

Step 7

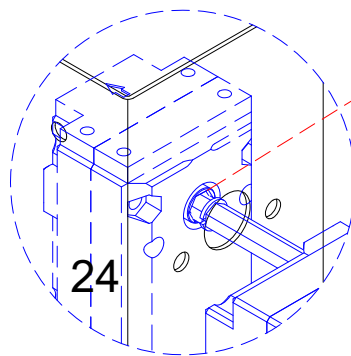
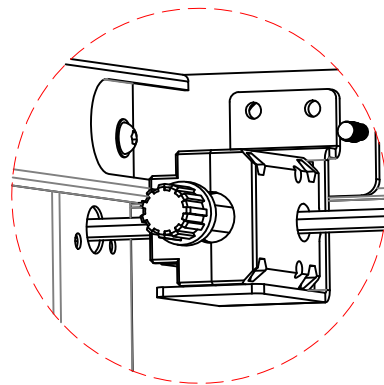
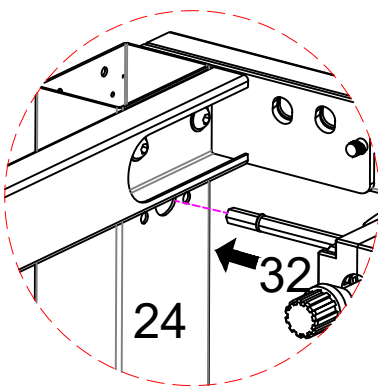
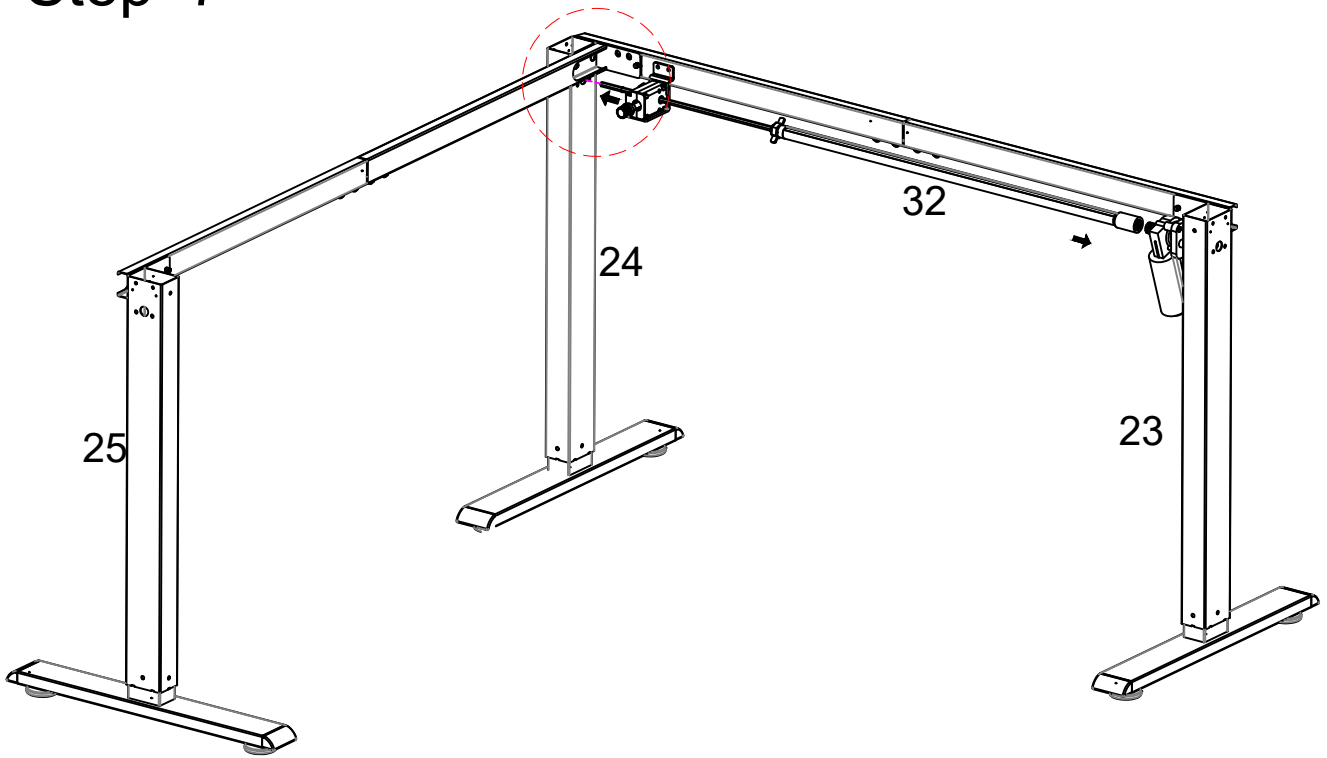

Circlip

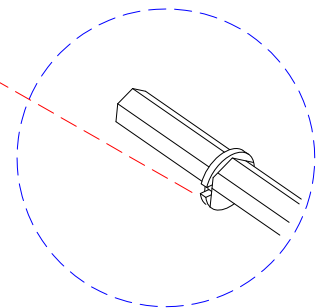

Fully insert the shaft into part 24 until the circlip stop it

Step 8

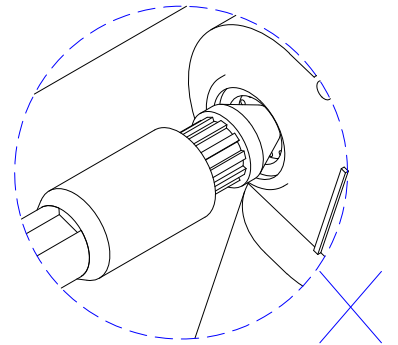
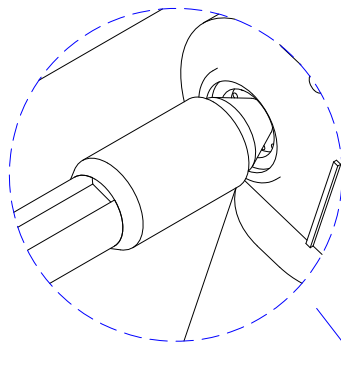
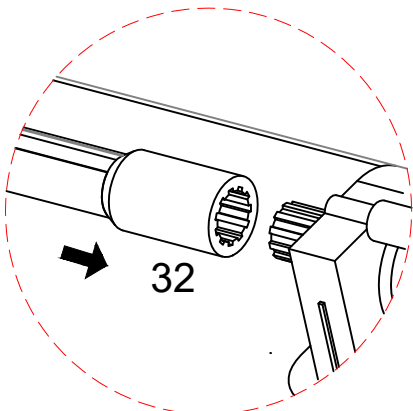
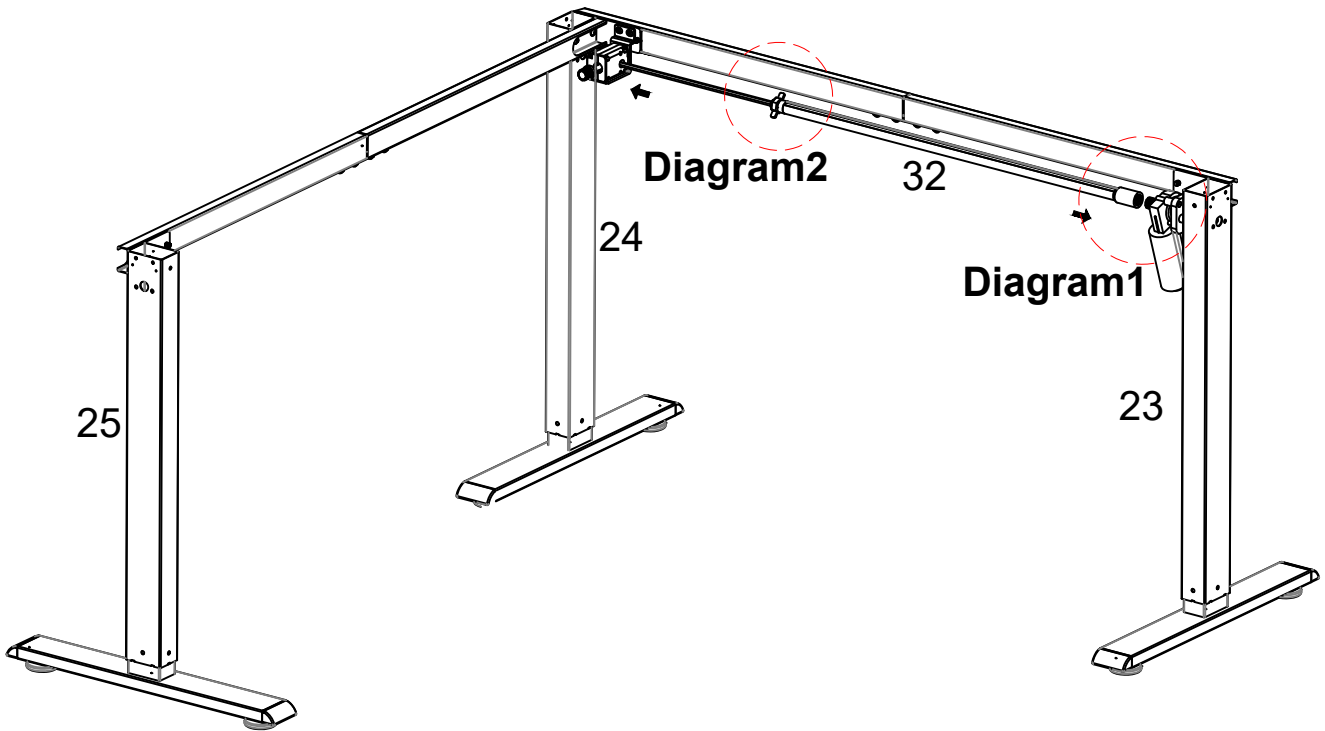

Diagram1 Connect the shaft to motor

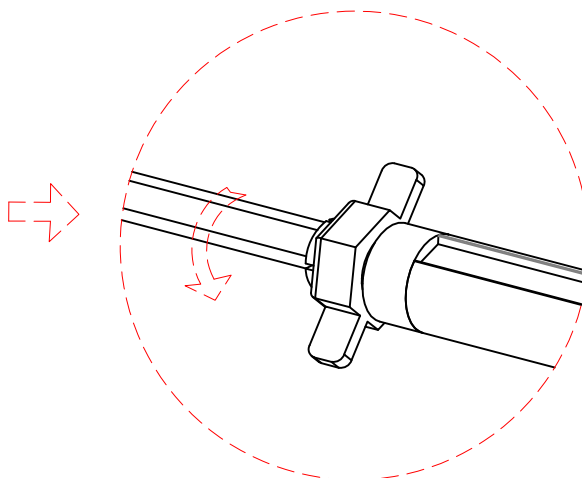
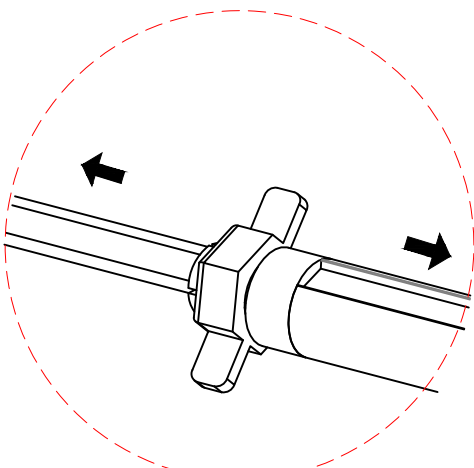
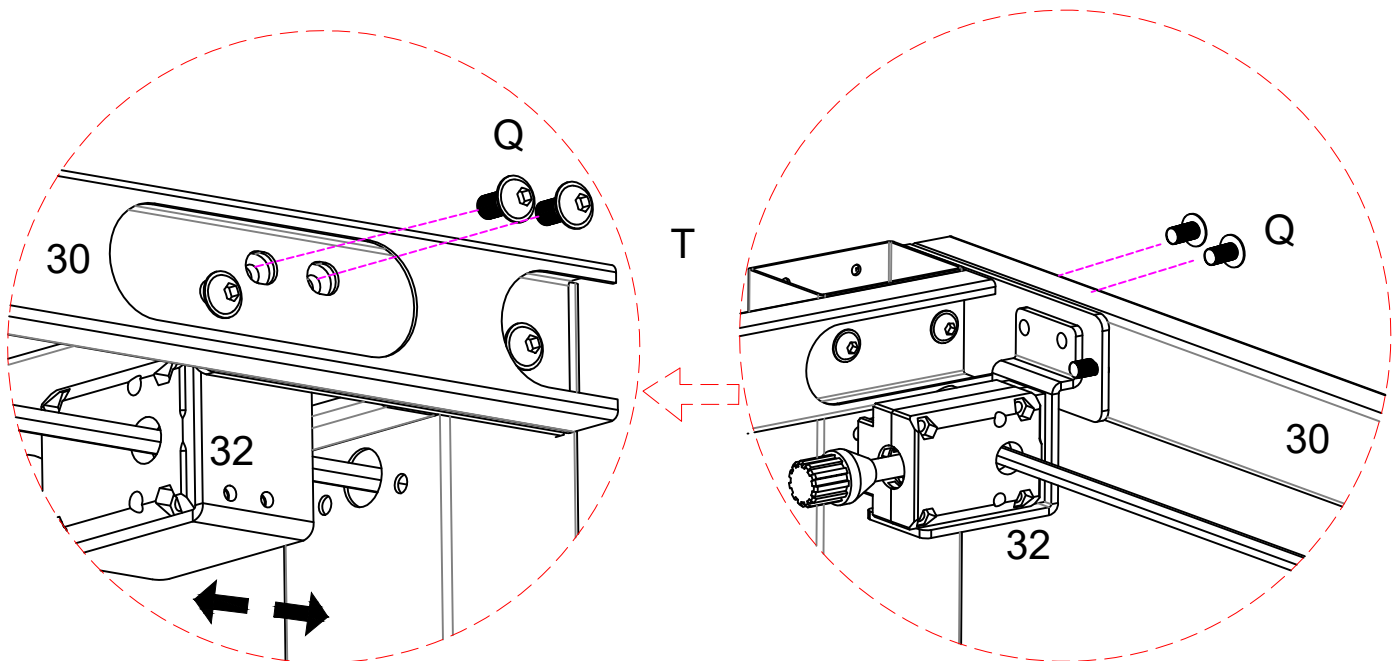
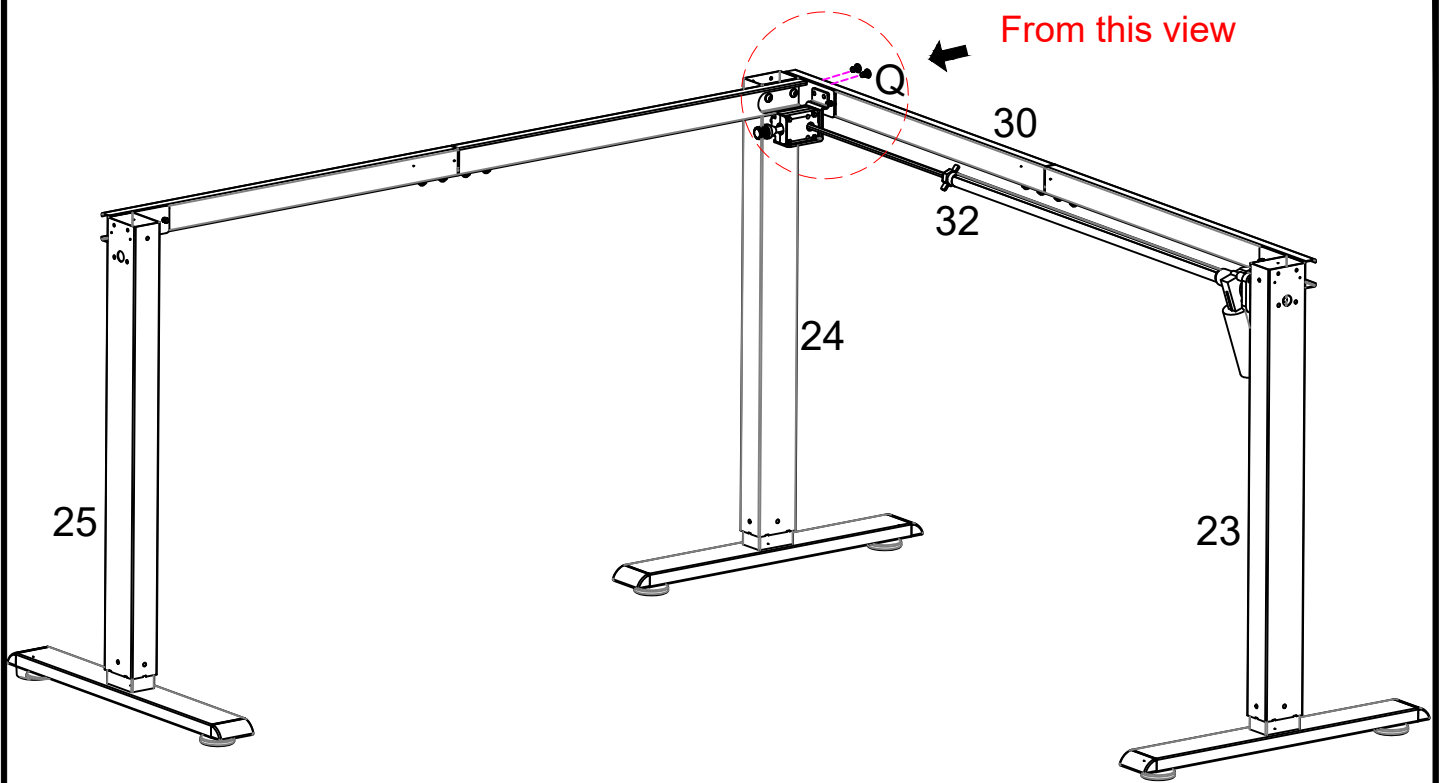

Diagram2

Tighten the plastic lock

(IMPORTANT! The shaft should be fully inserted to the part 24 and motor before tighten the plastic lock)

Step 9



Note: If necessary to slide the steering gear on the shaft for aligning the holes

Step 10

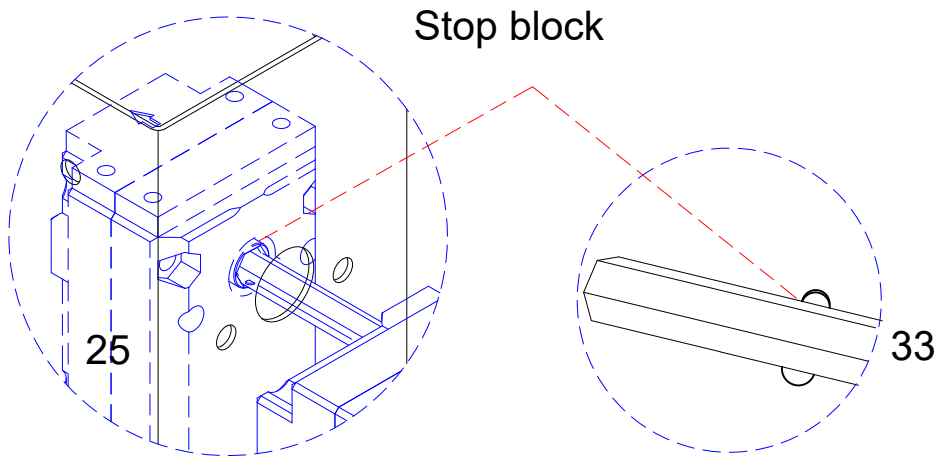
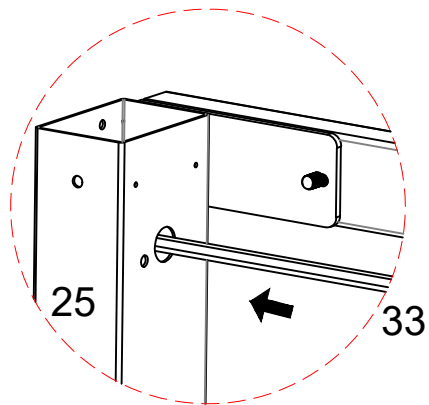
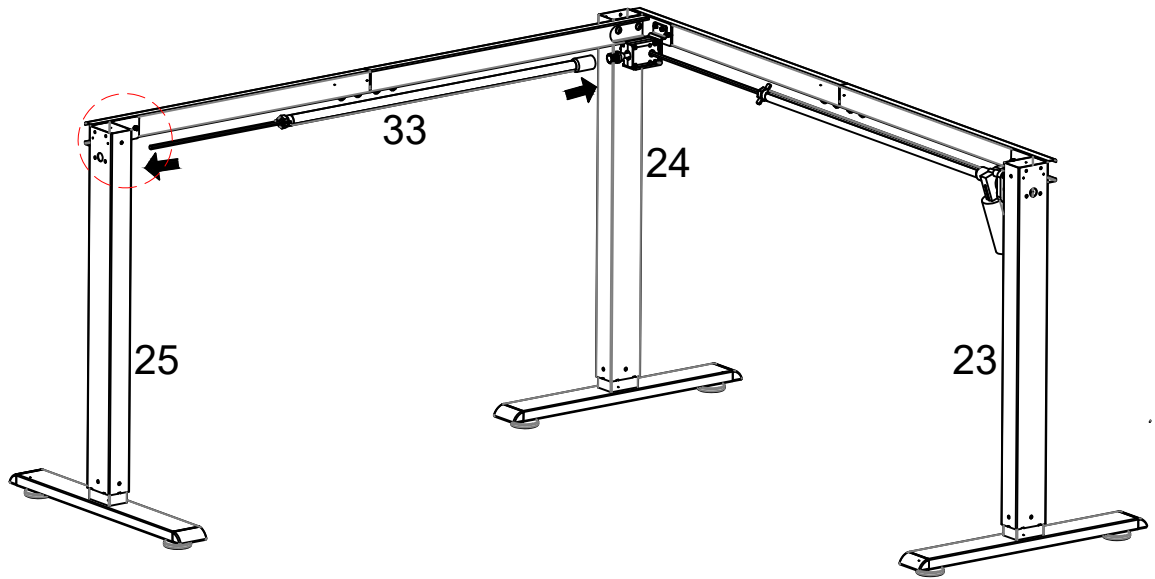

Fully insert the shaft into part 25 until the Stop block stop it

Step 11

Diagram1

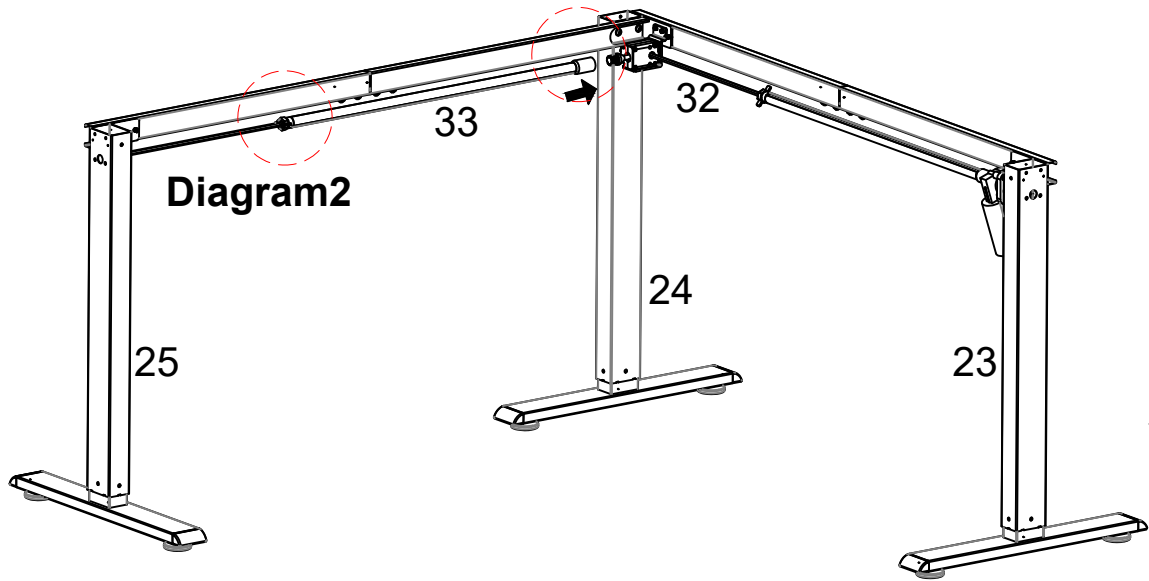

Diagram2

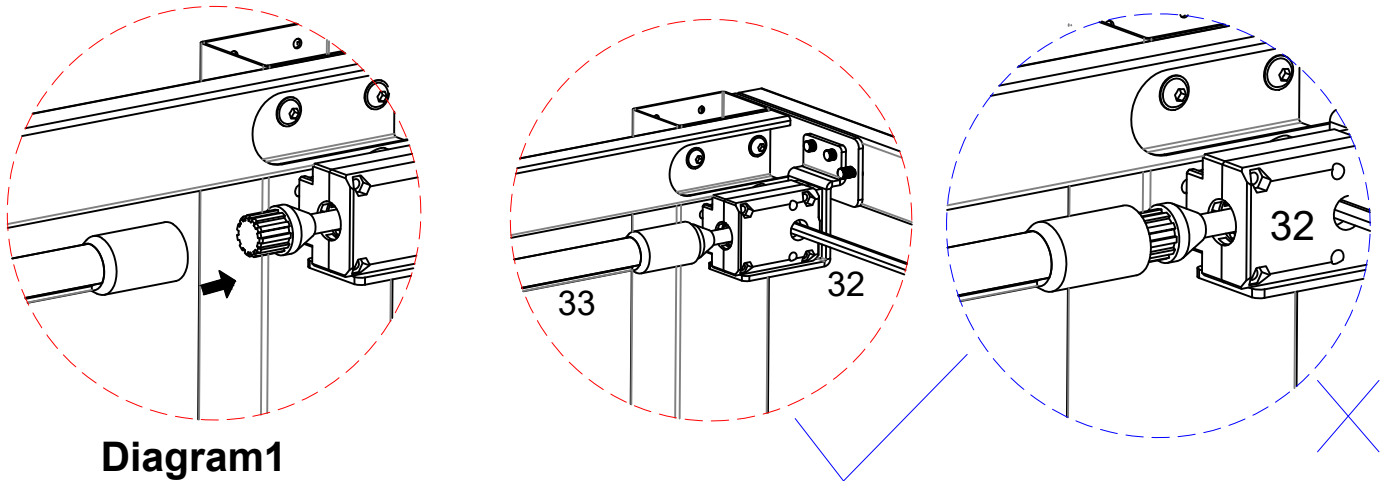

Diagram1

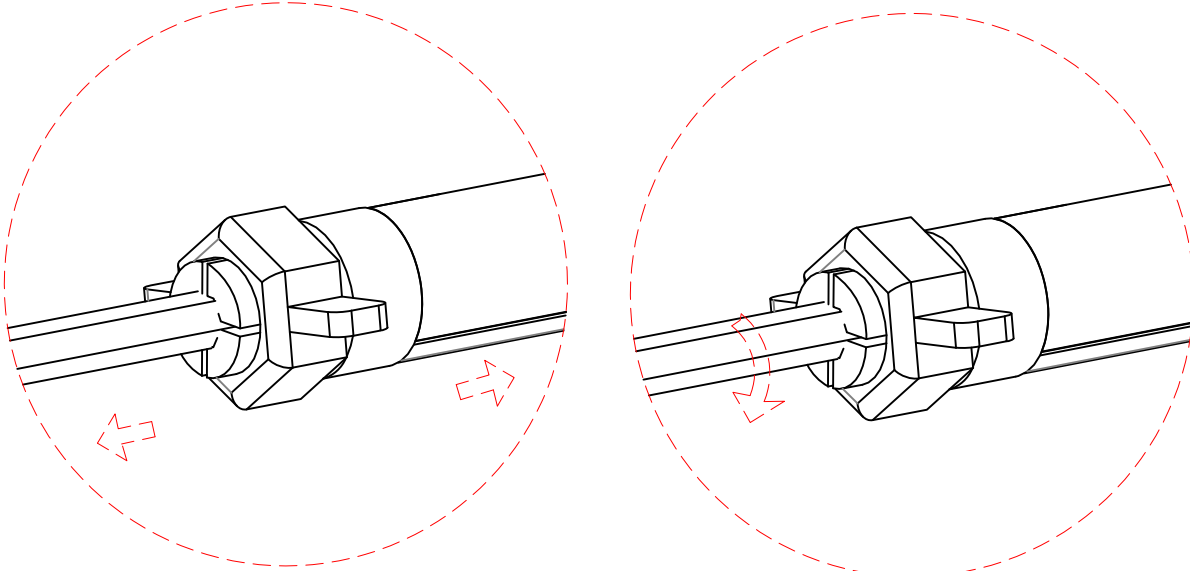

Diagram2

Tighten the plastic lock
(IMPORTANT! The shaft should be fully inserted to the part 25 and 32 before tighten the plastic lock)

Step 12

Plug the Connector cable (L) into the Motor cable

Motor cable

L

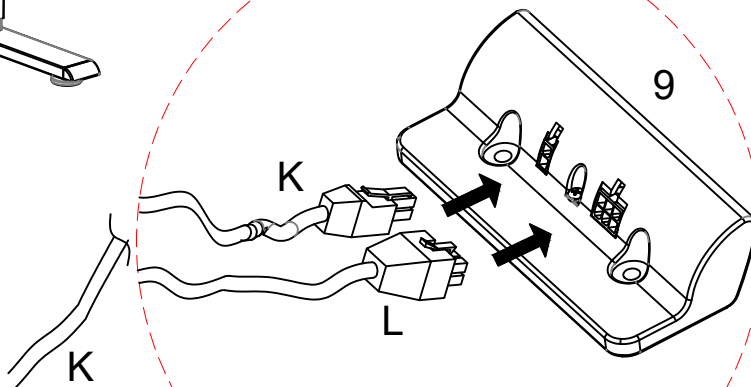
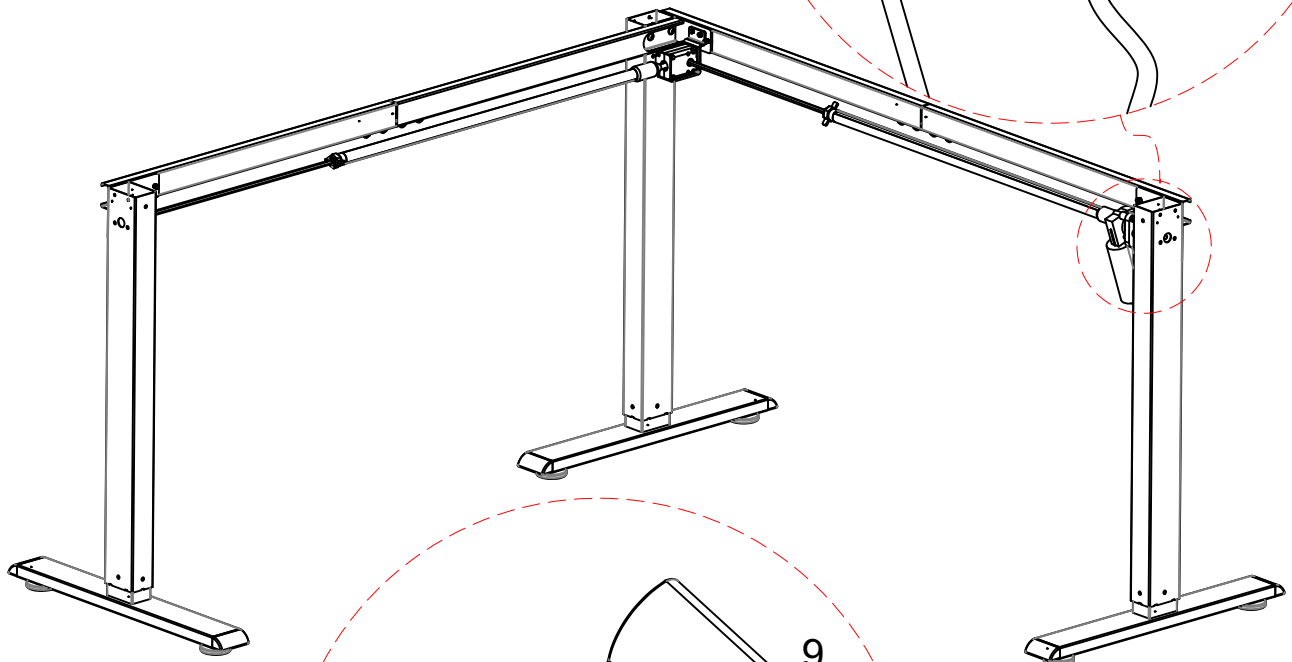

Plug the Adapter cable (K) and Connector cable (L) into the Control monitor (9)

We recommend connecting the motor cable with the control monitor to test if the lifting motor works correctly or not before starting next step. In case of any error code, Please refer to user instruction at the last page.

Step 13

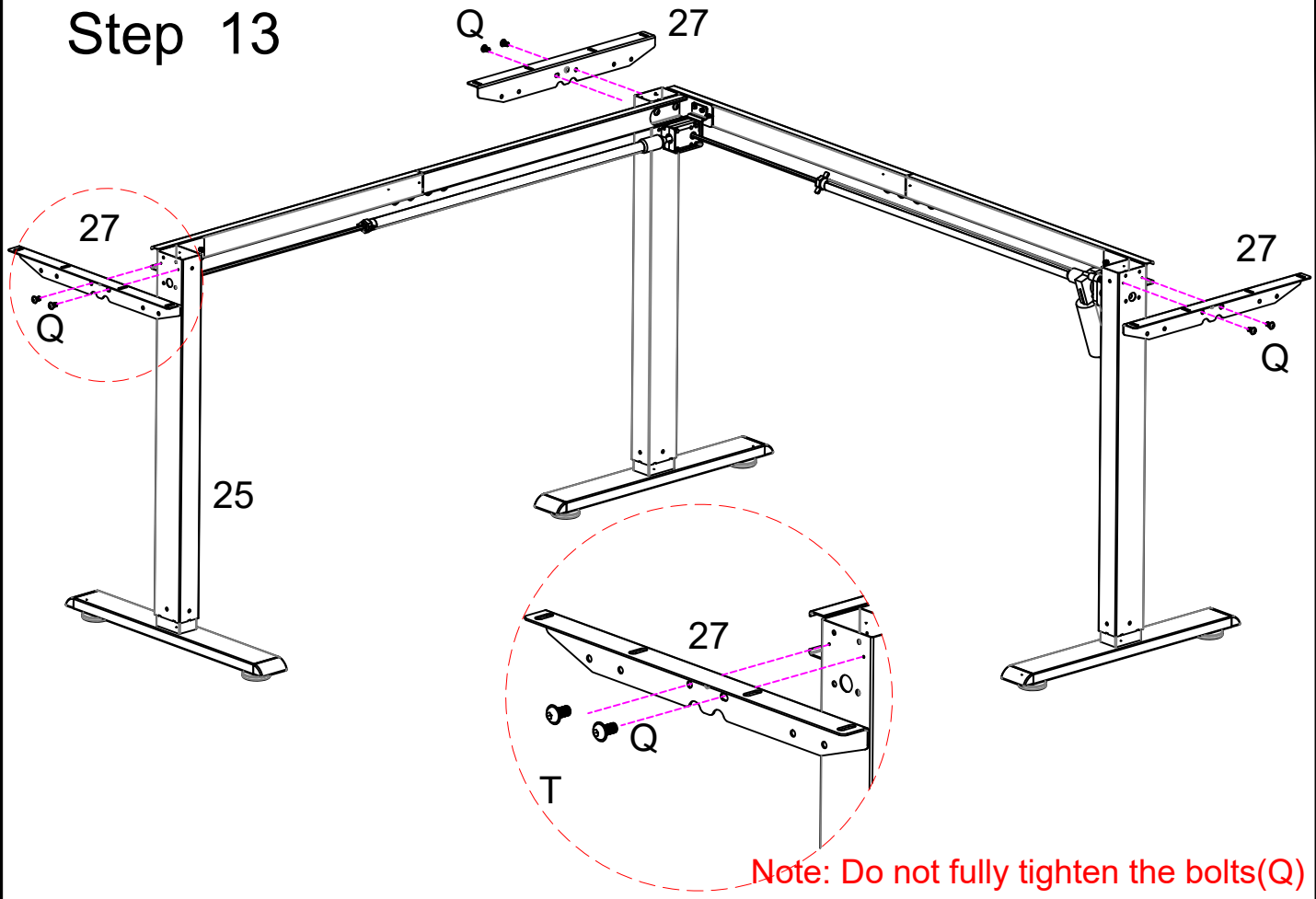

Step 14

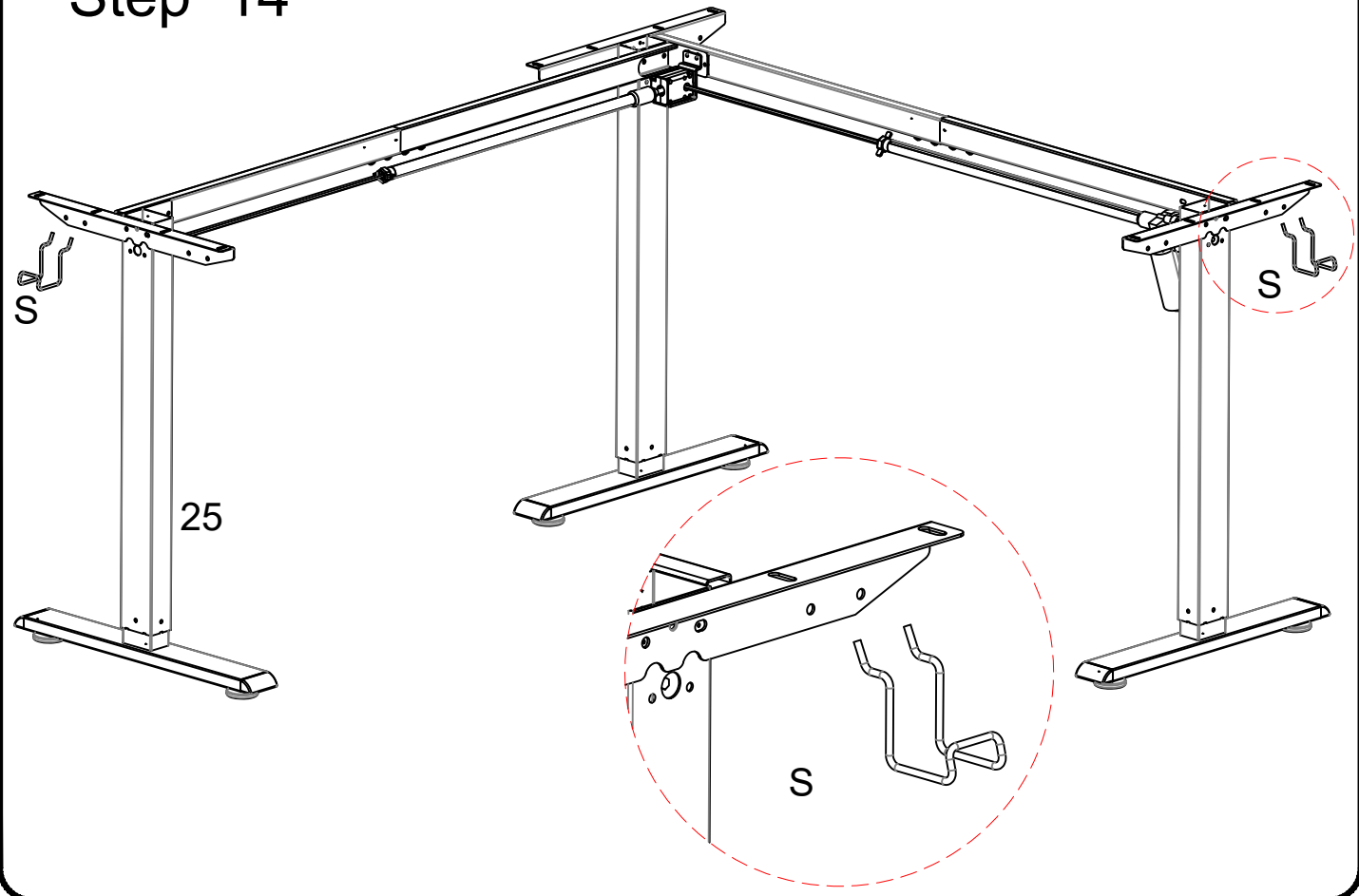

Step 15

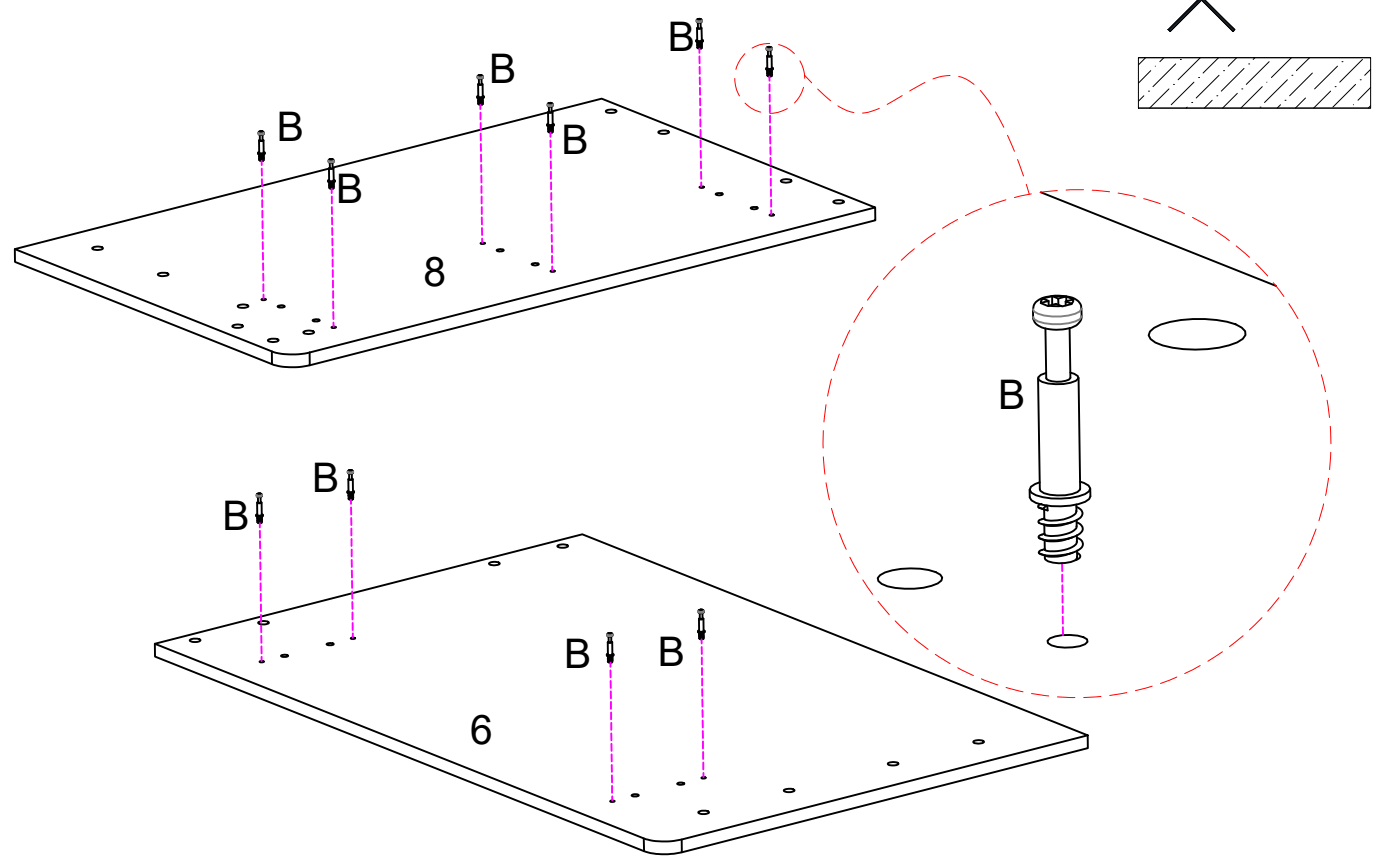

Step 16

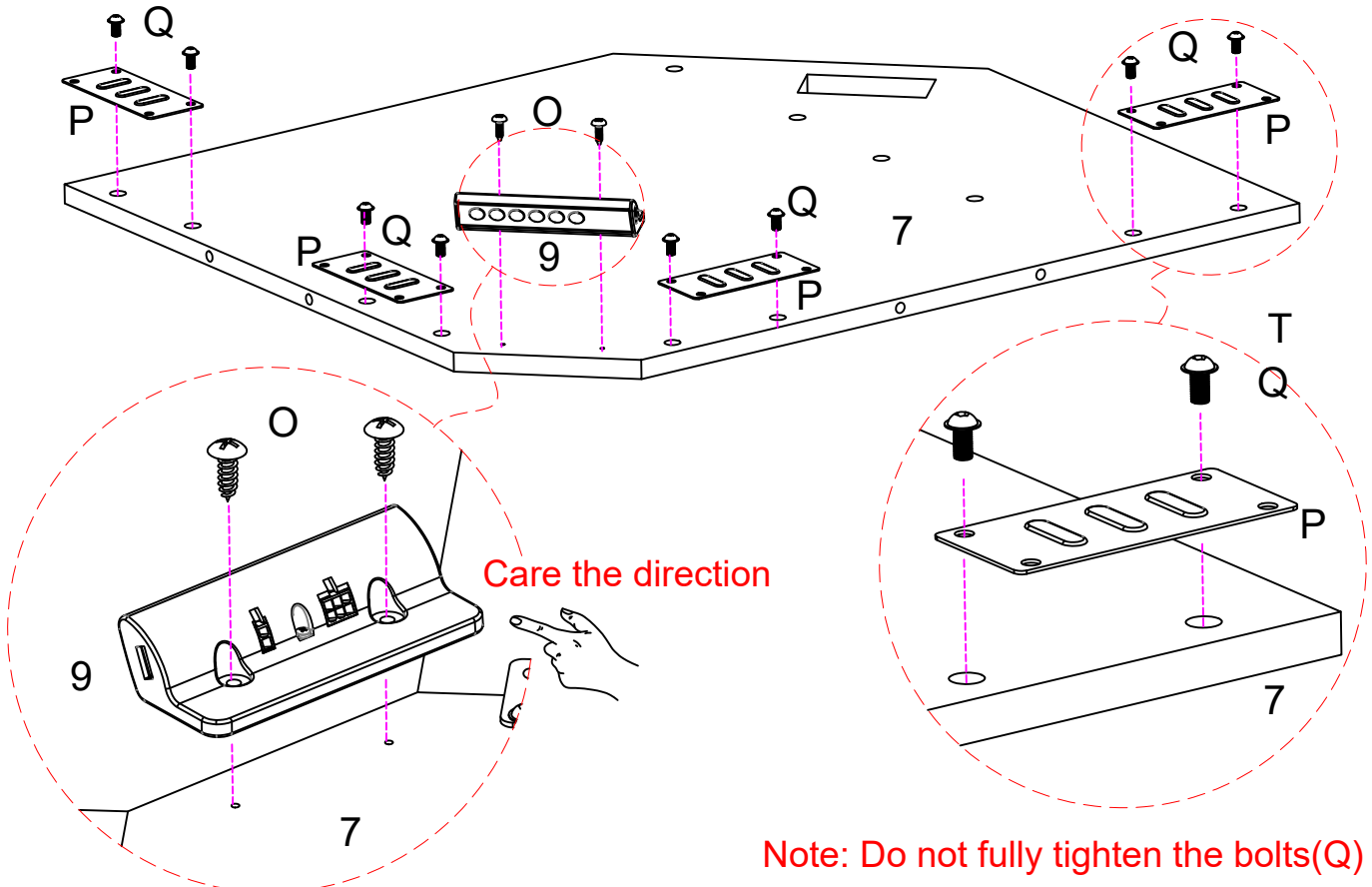

Step 17

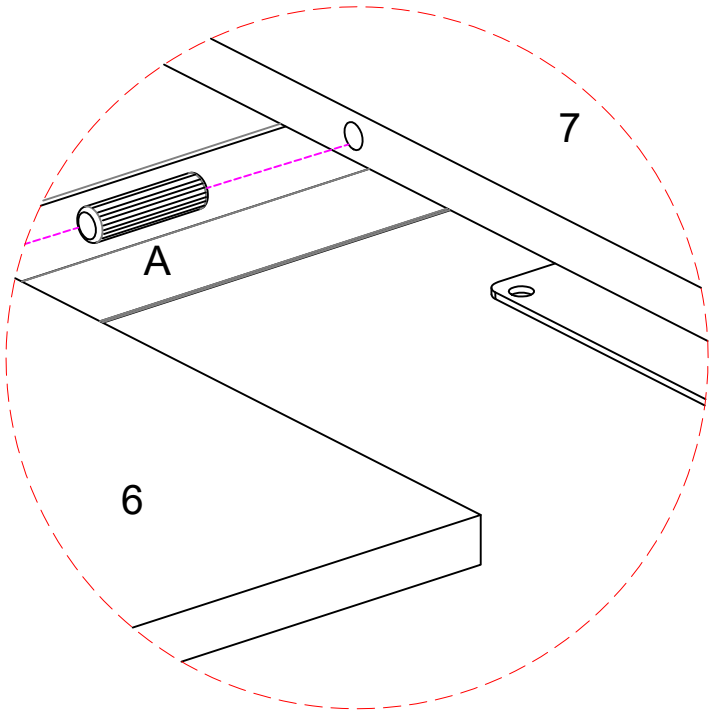
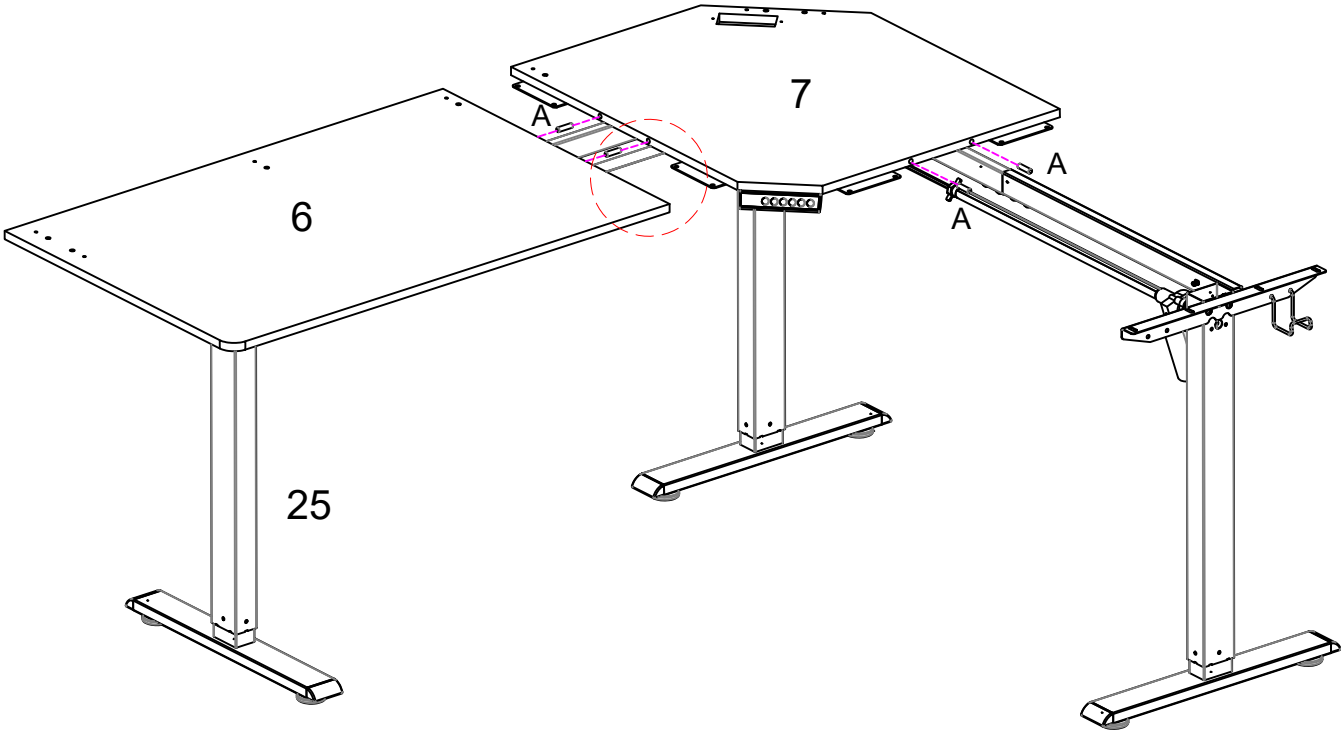

Step 18

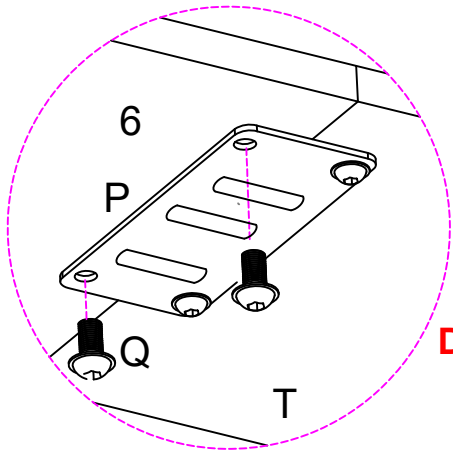
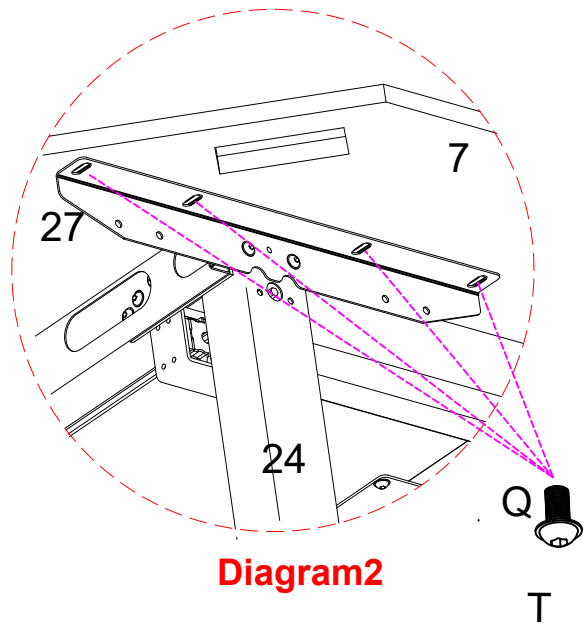
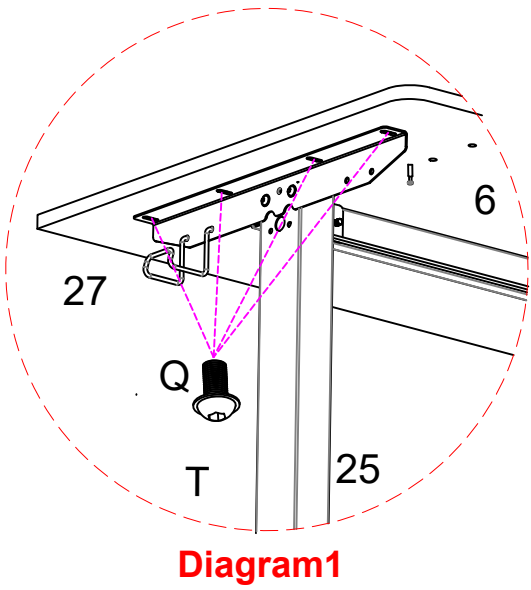
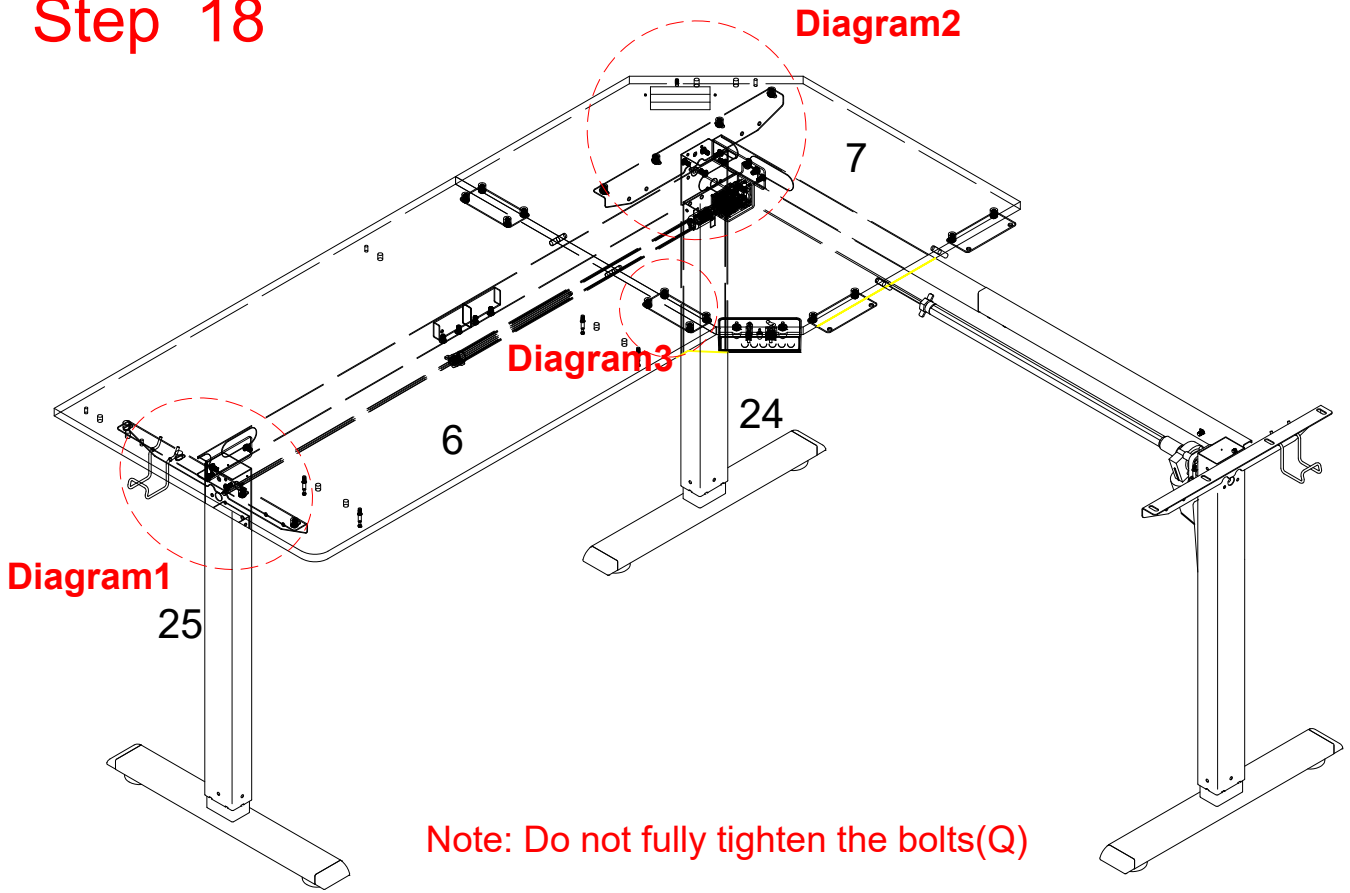

Step 19

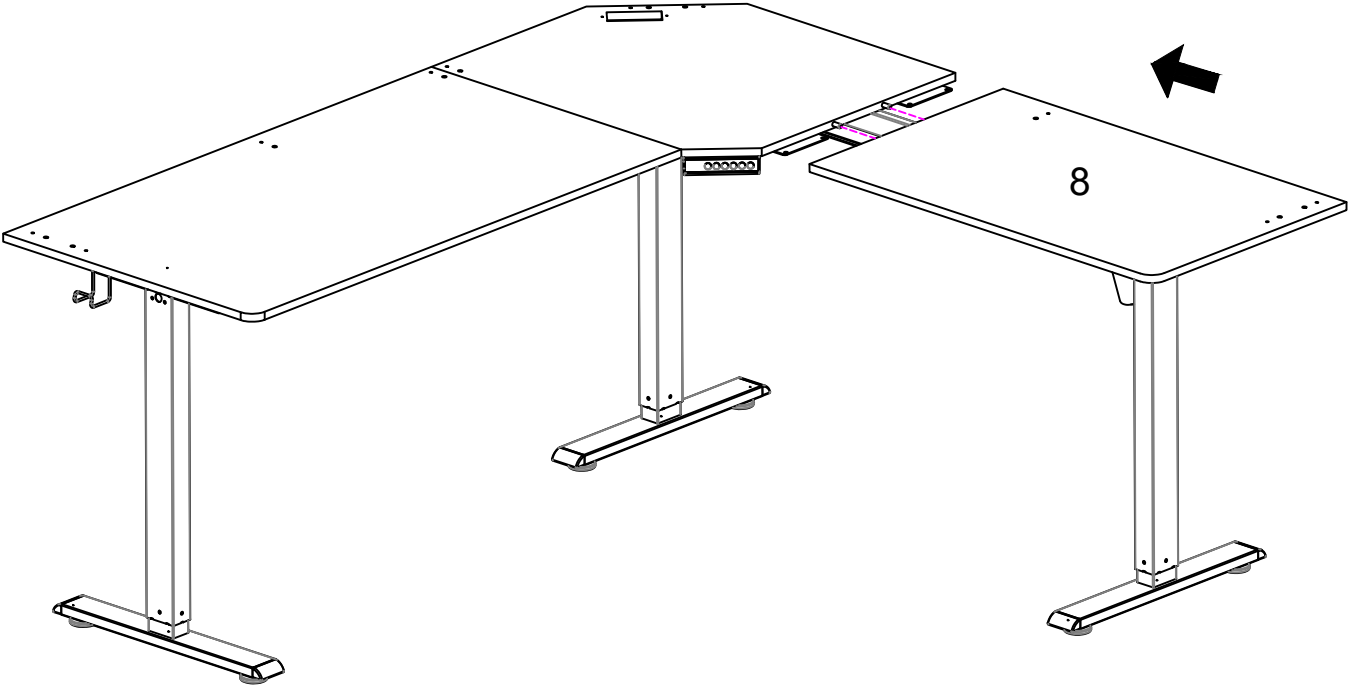

CAUTION: You may need assistance with this step.

Step 20

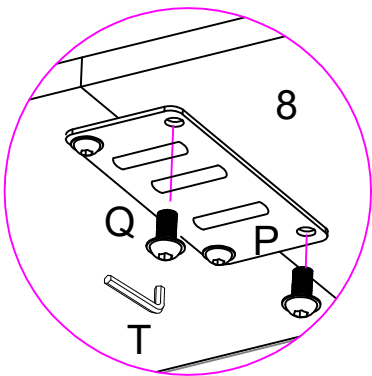
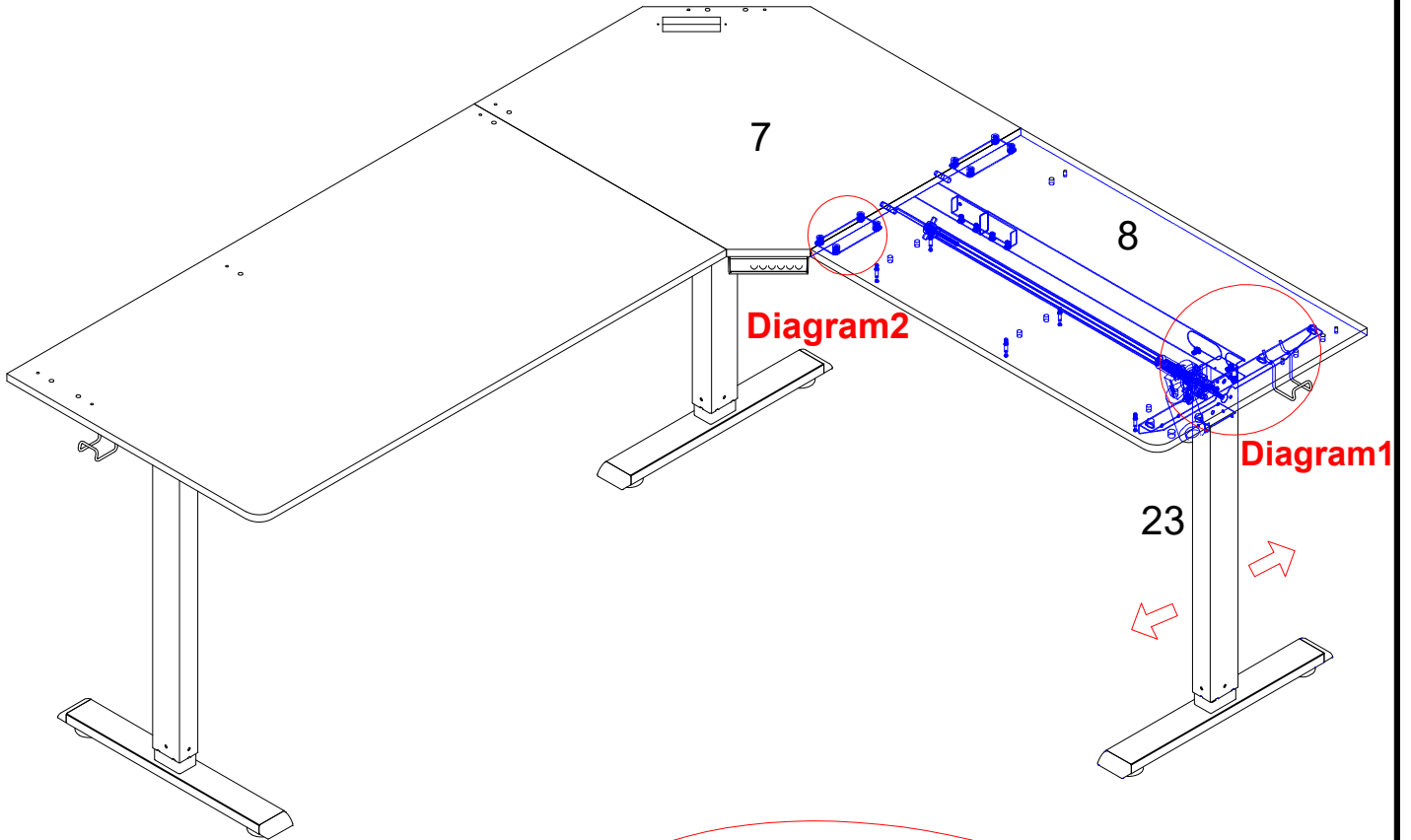

Diagram2

Refer to Step14 to install the part (8), then fully tighten all bolts(Q) from Step9 onwards.

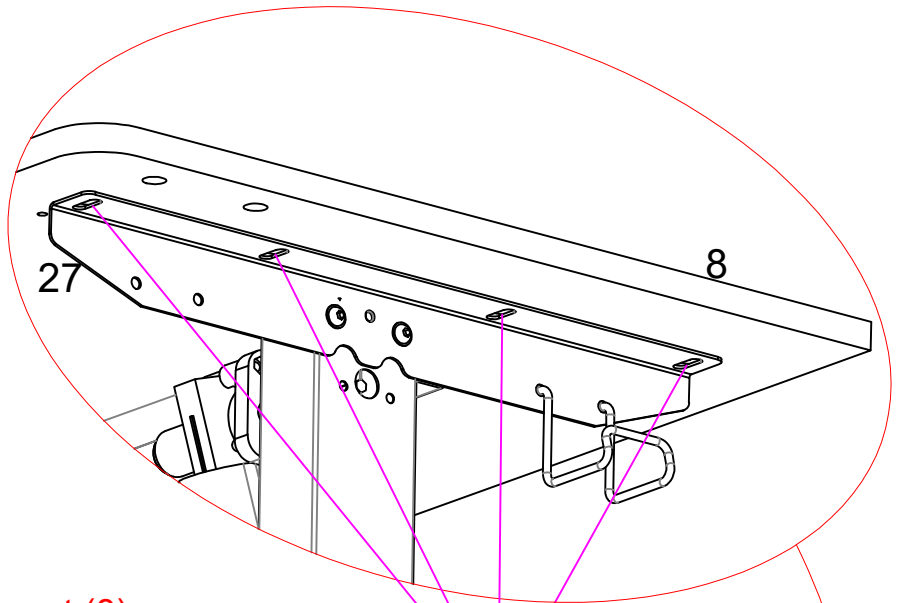
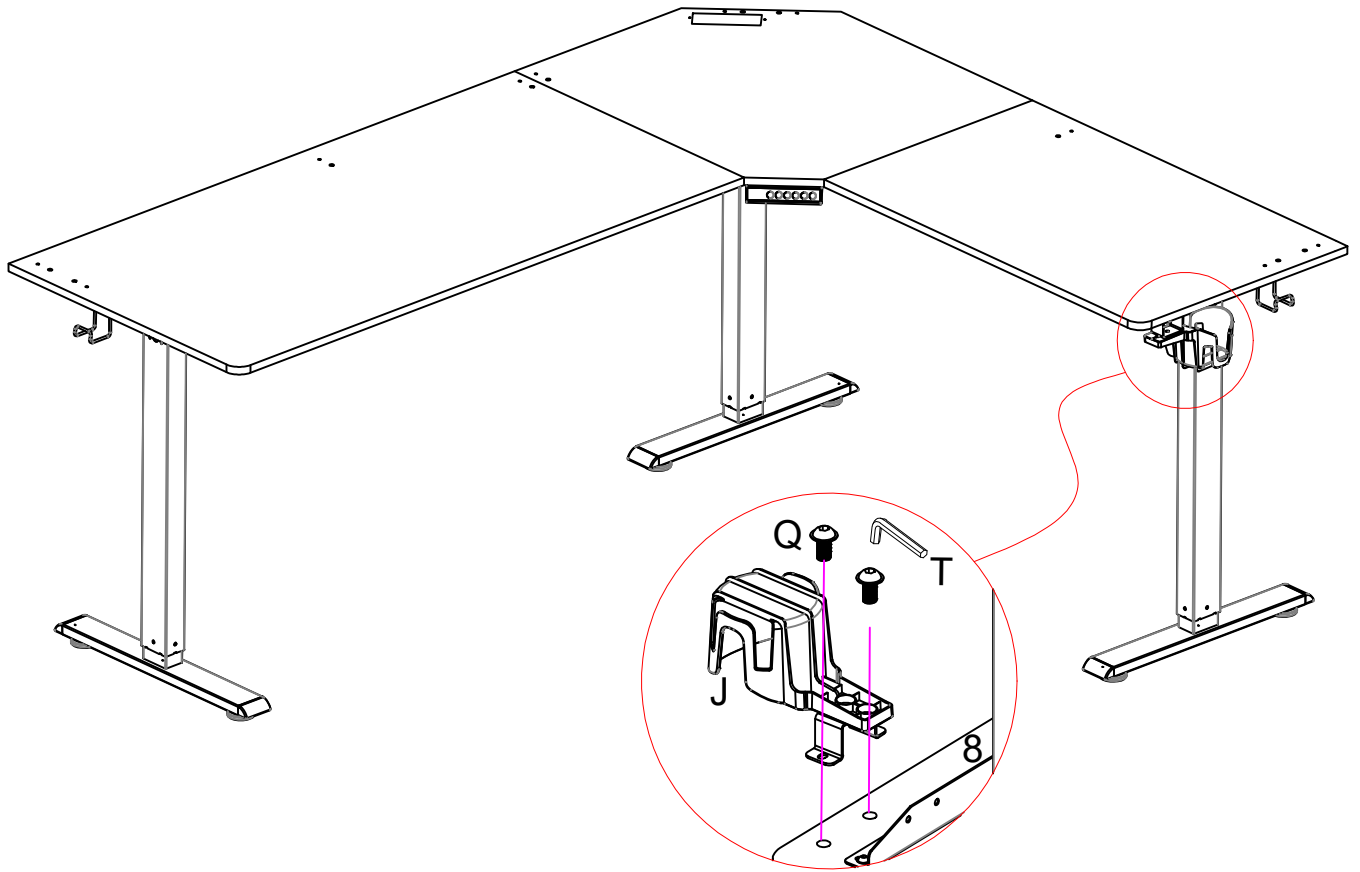

Diagram1



Note: This step may require moving the leg frame (23) to align the holes on part (27) and (8)

Step 21



Step 22

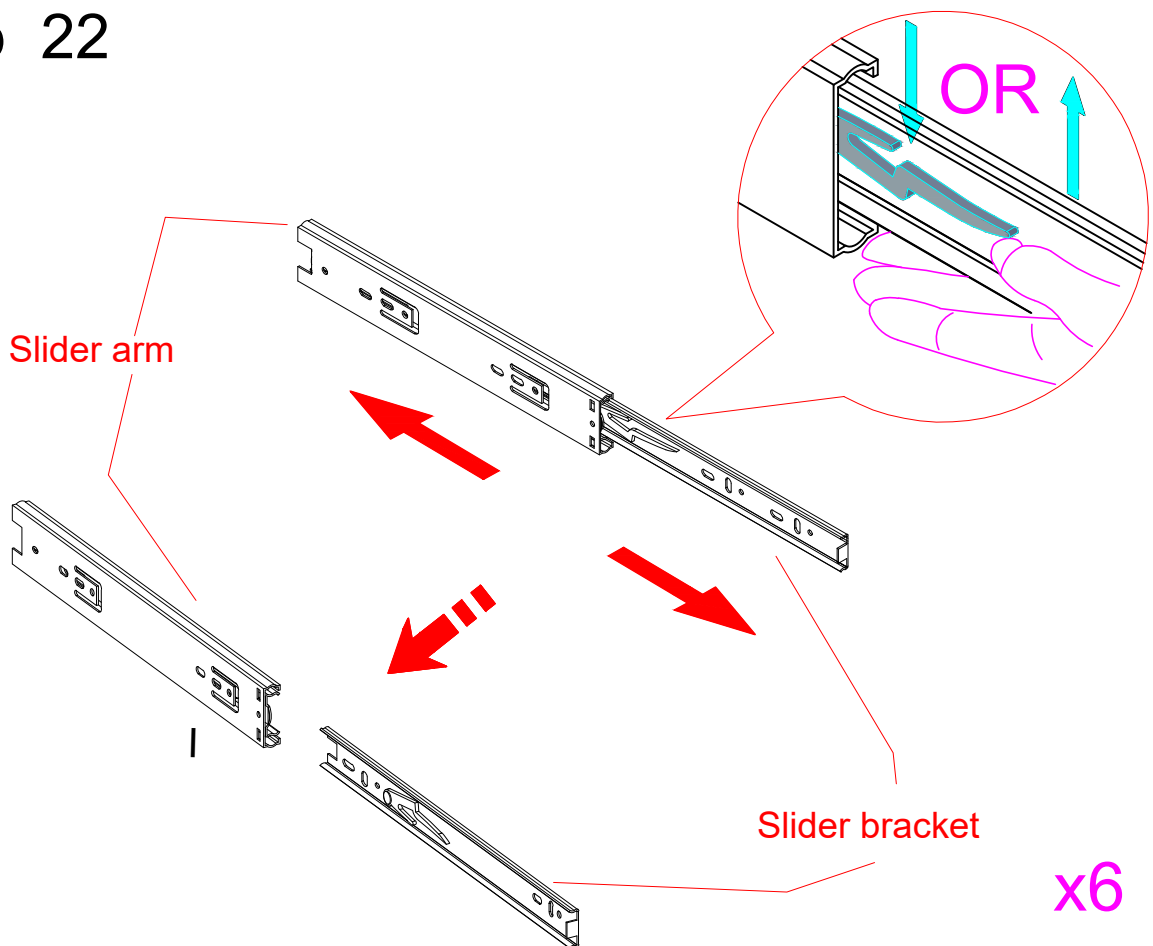

Step 25

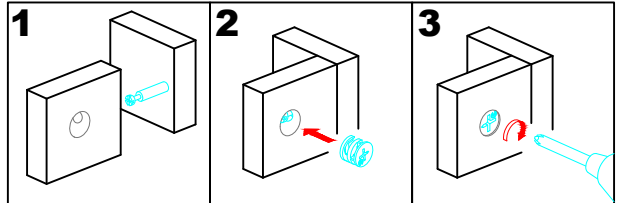
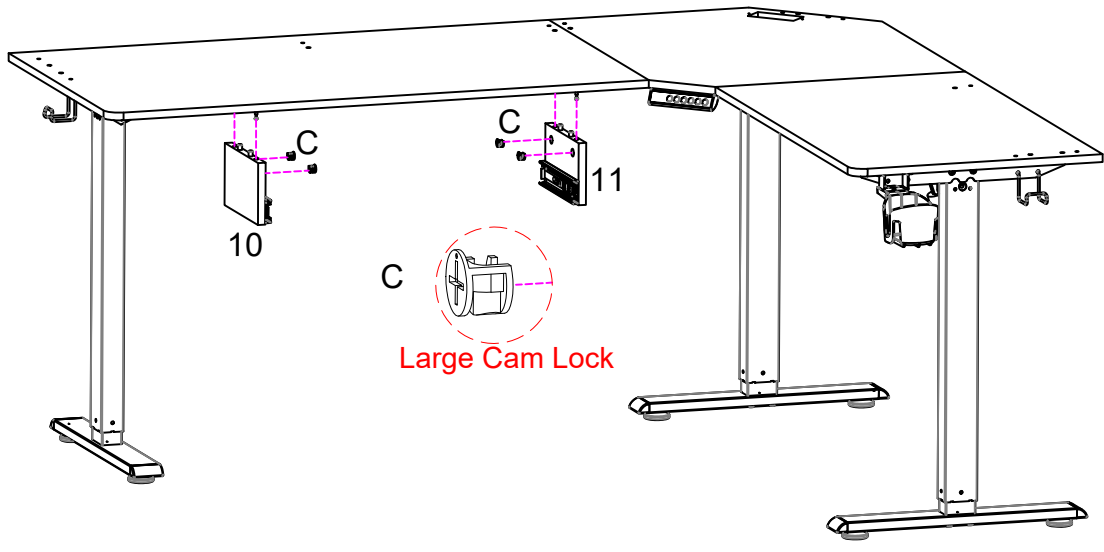

Step 26

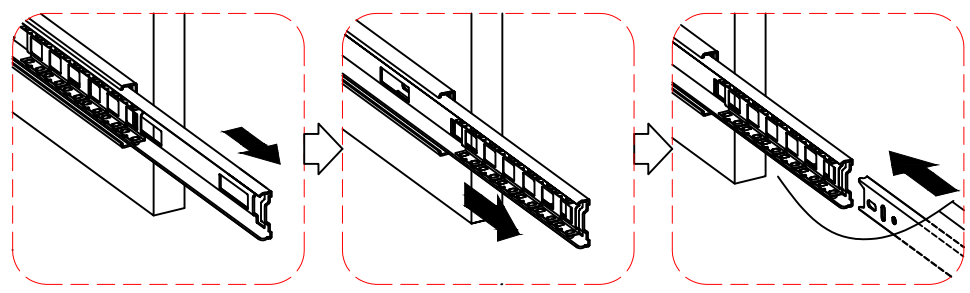
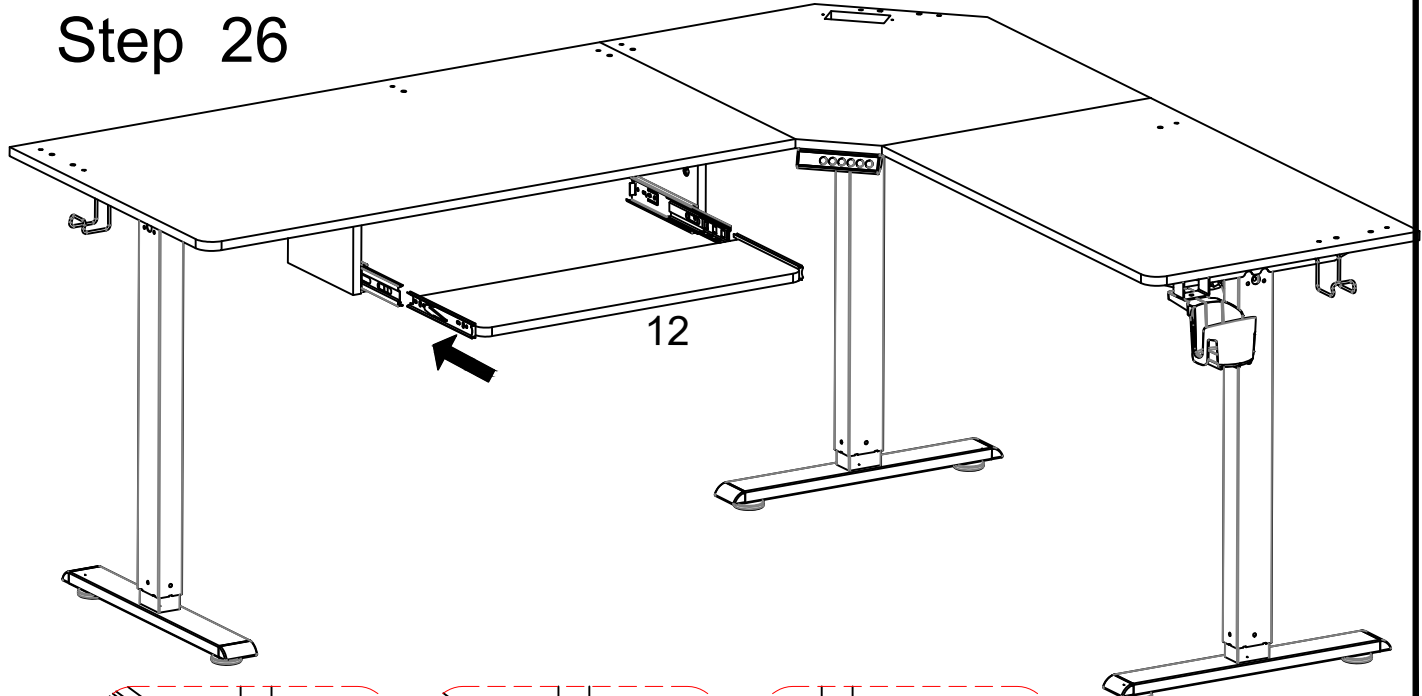

Step 27

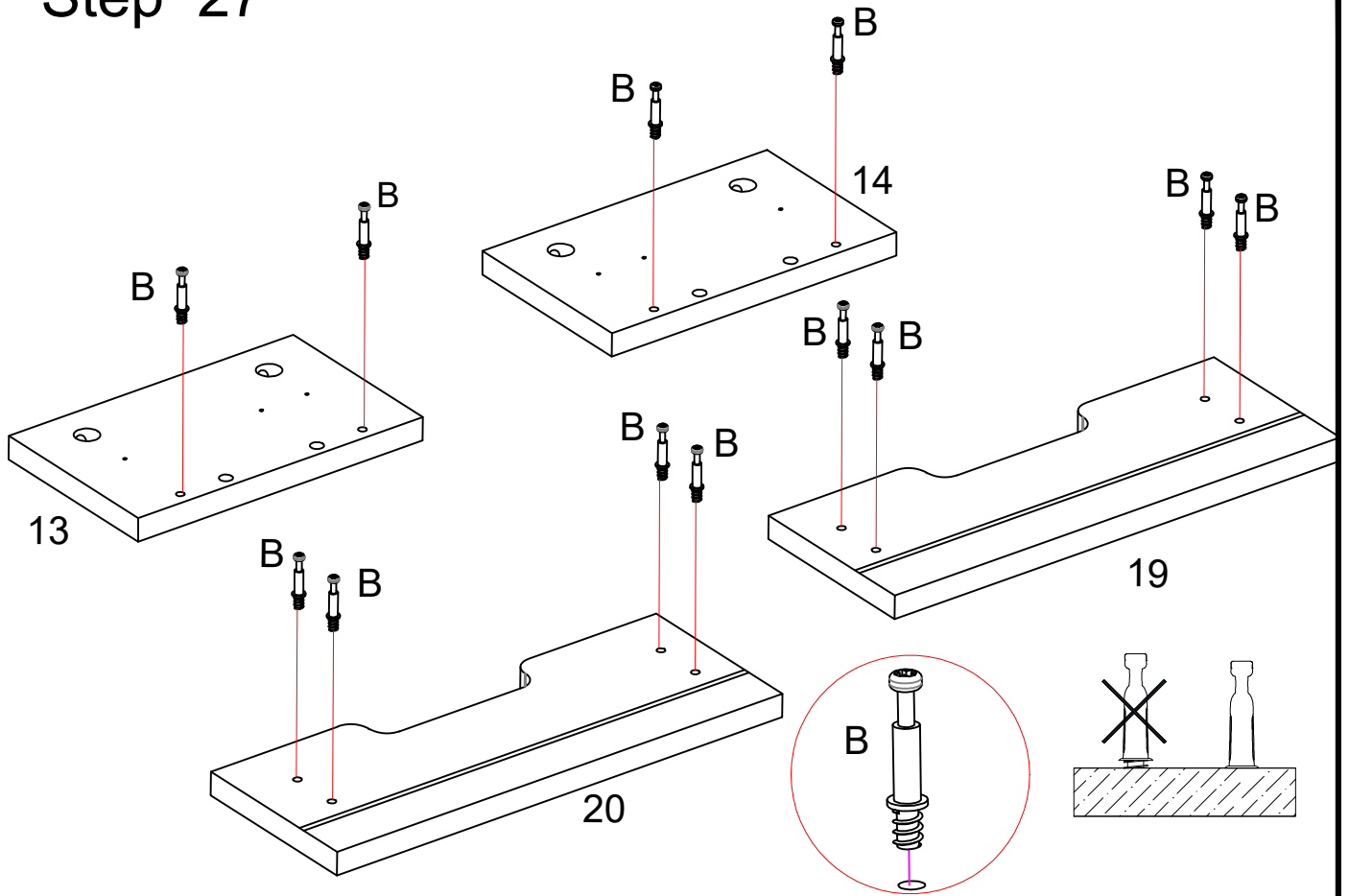

Step 28

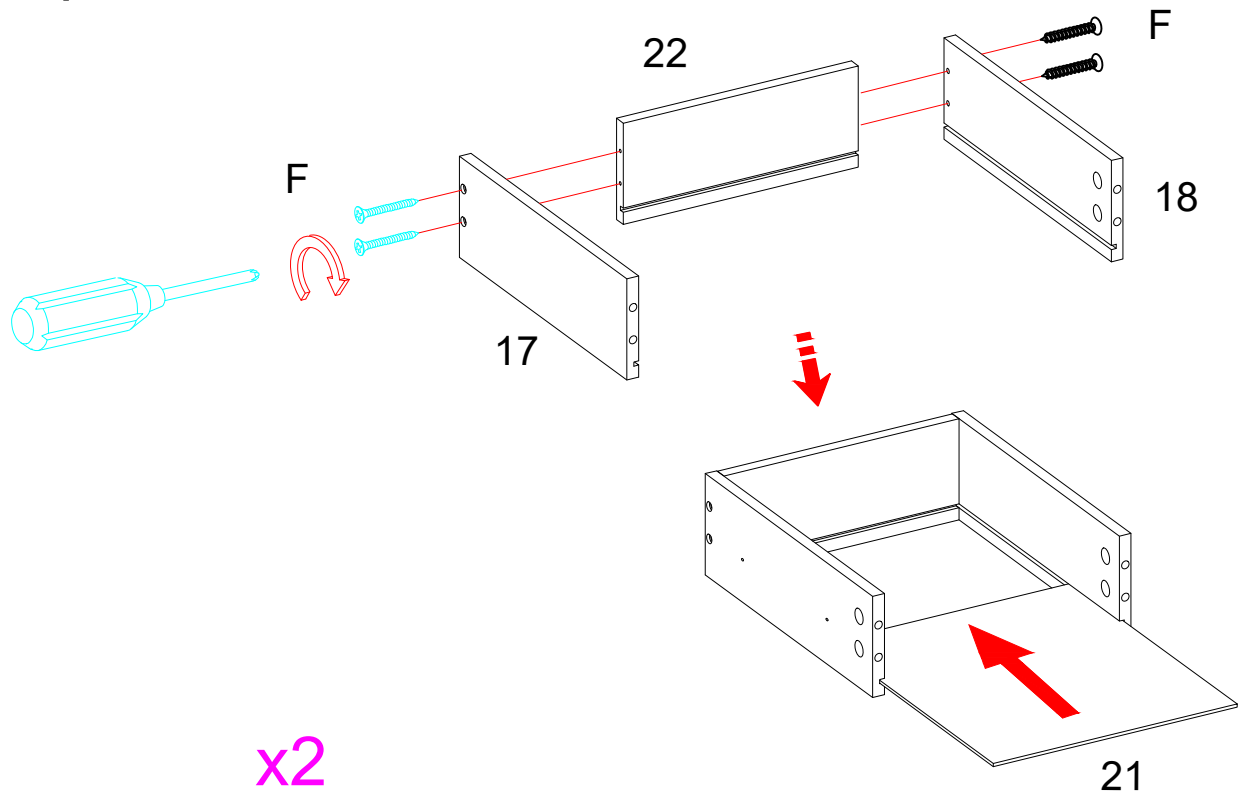

Step 29

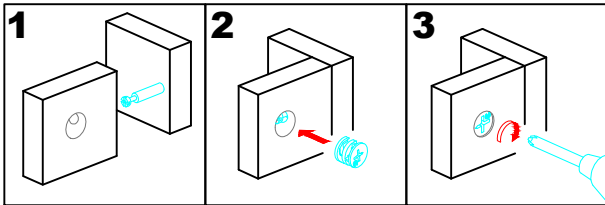
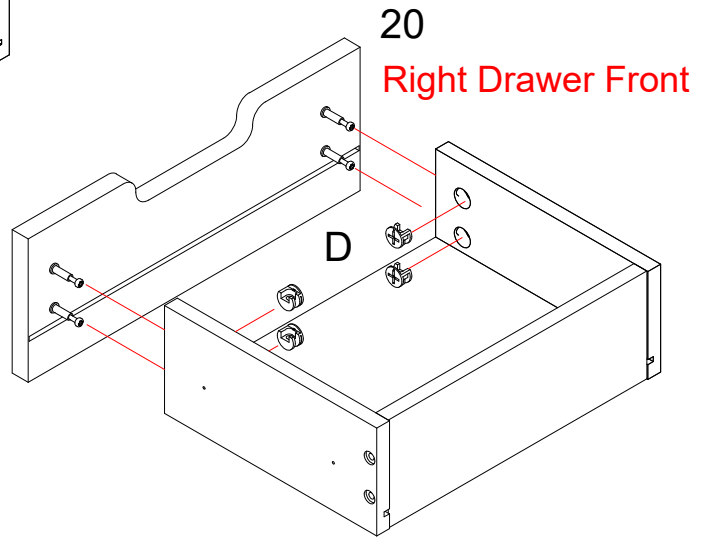
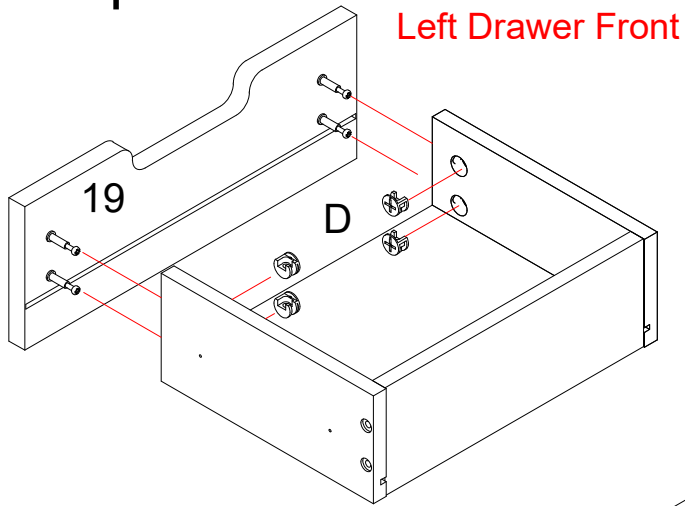

Step 30

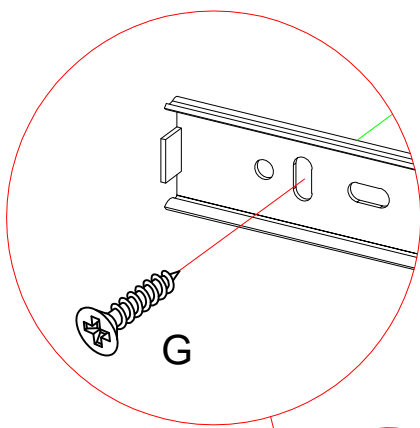
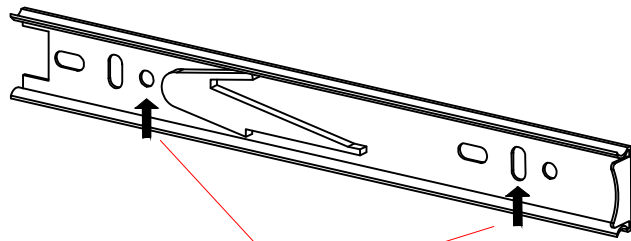

x2

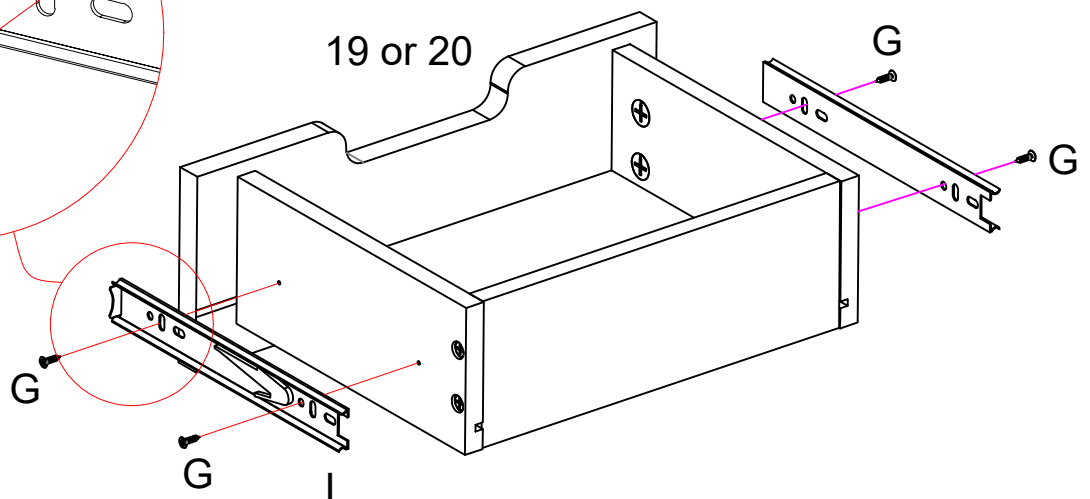

Step 31

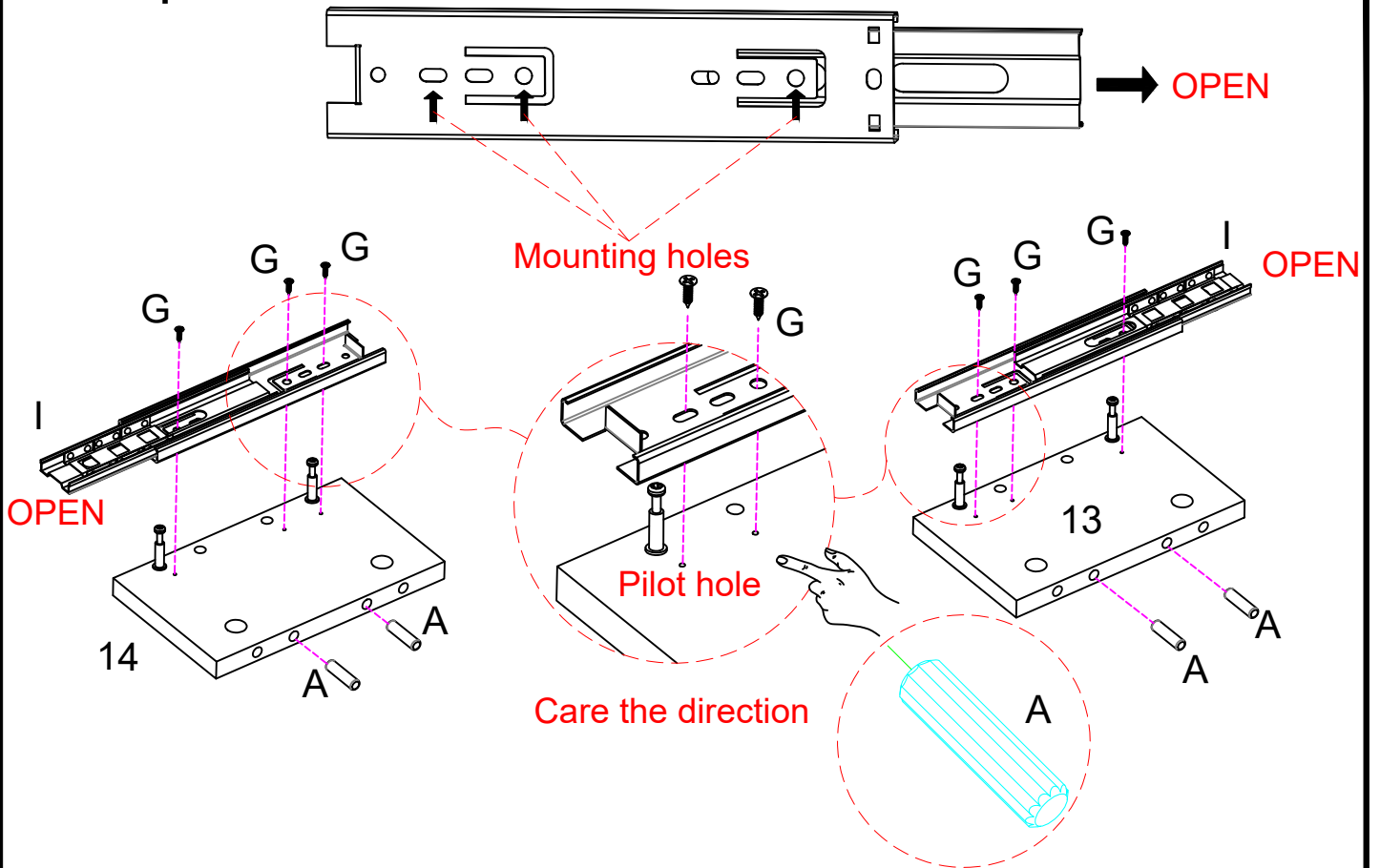

Step 32

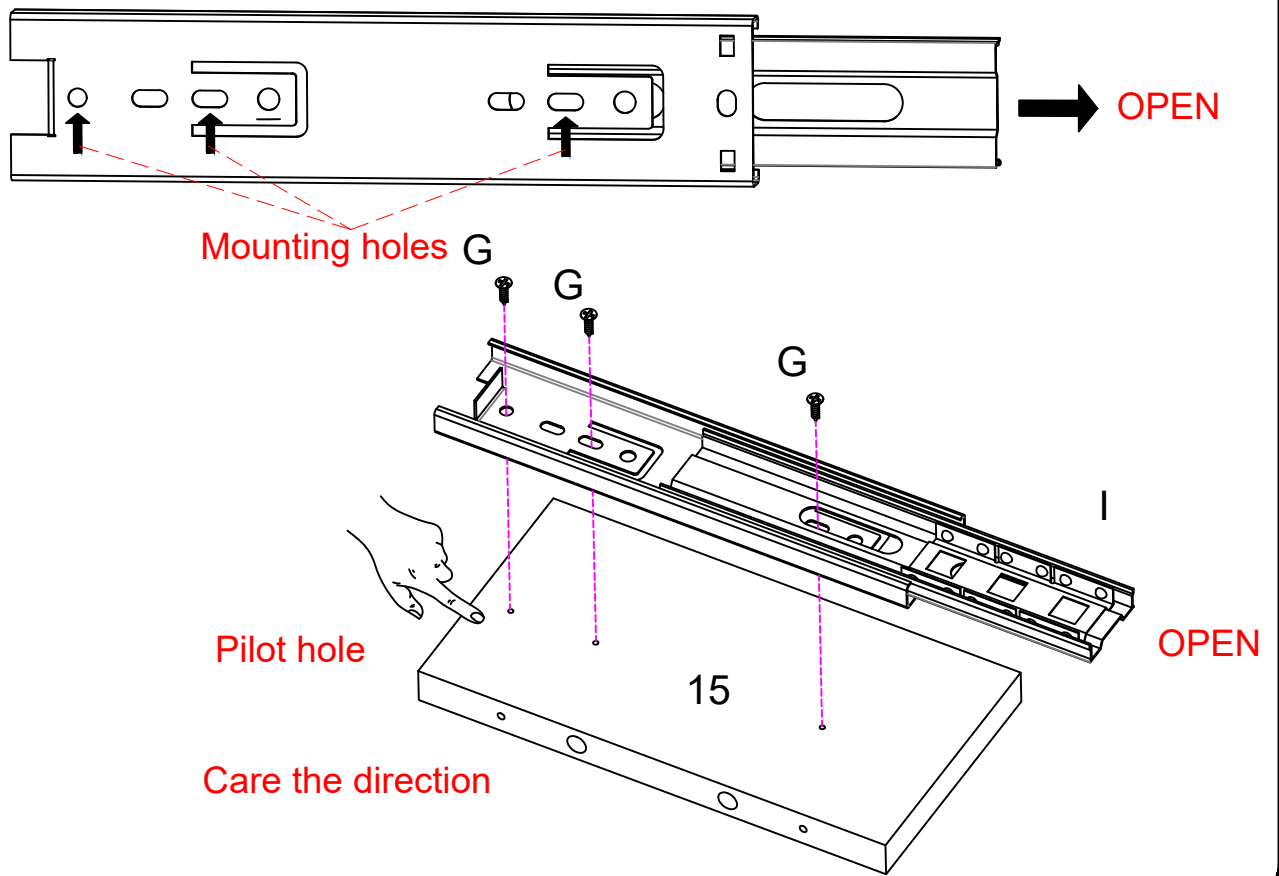

Step 33

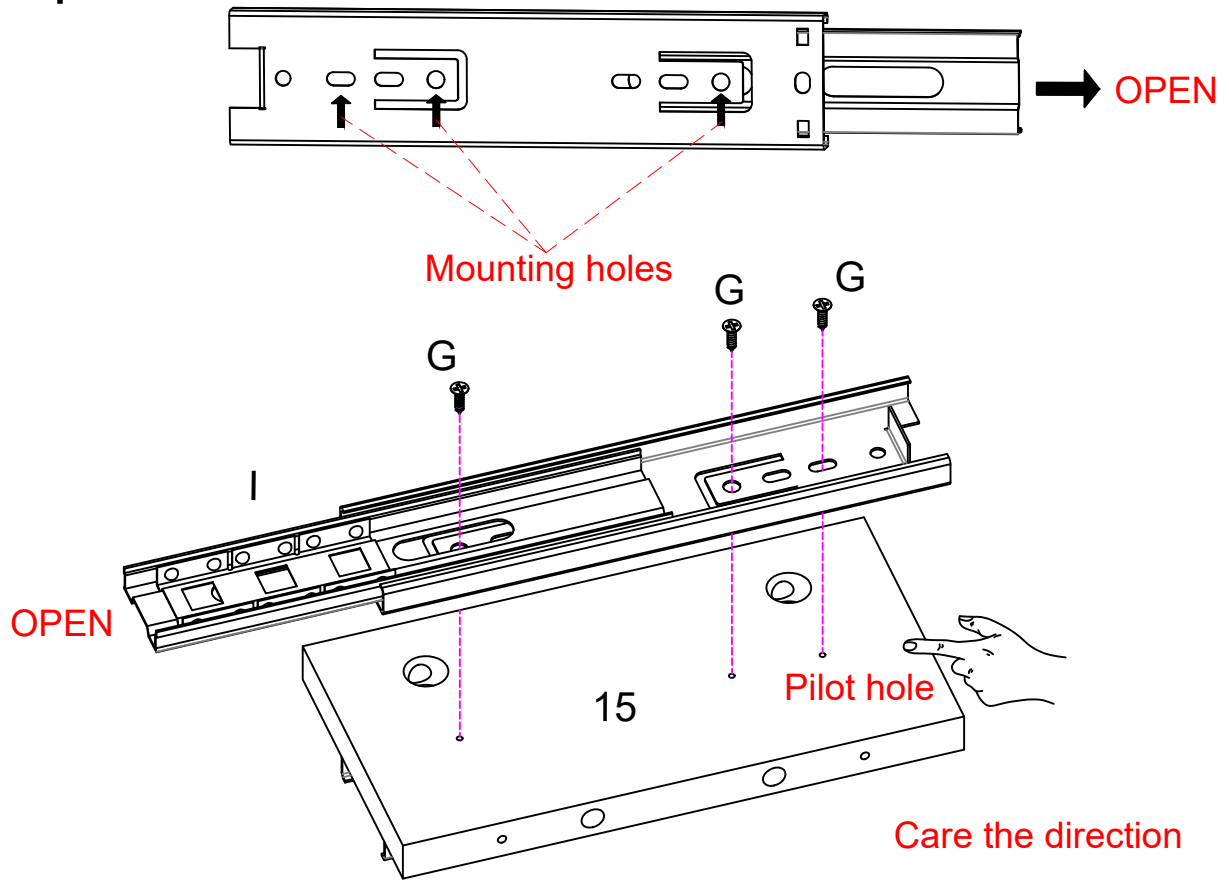

Step 34

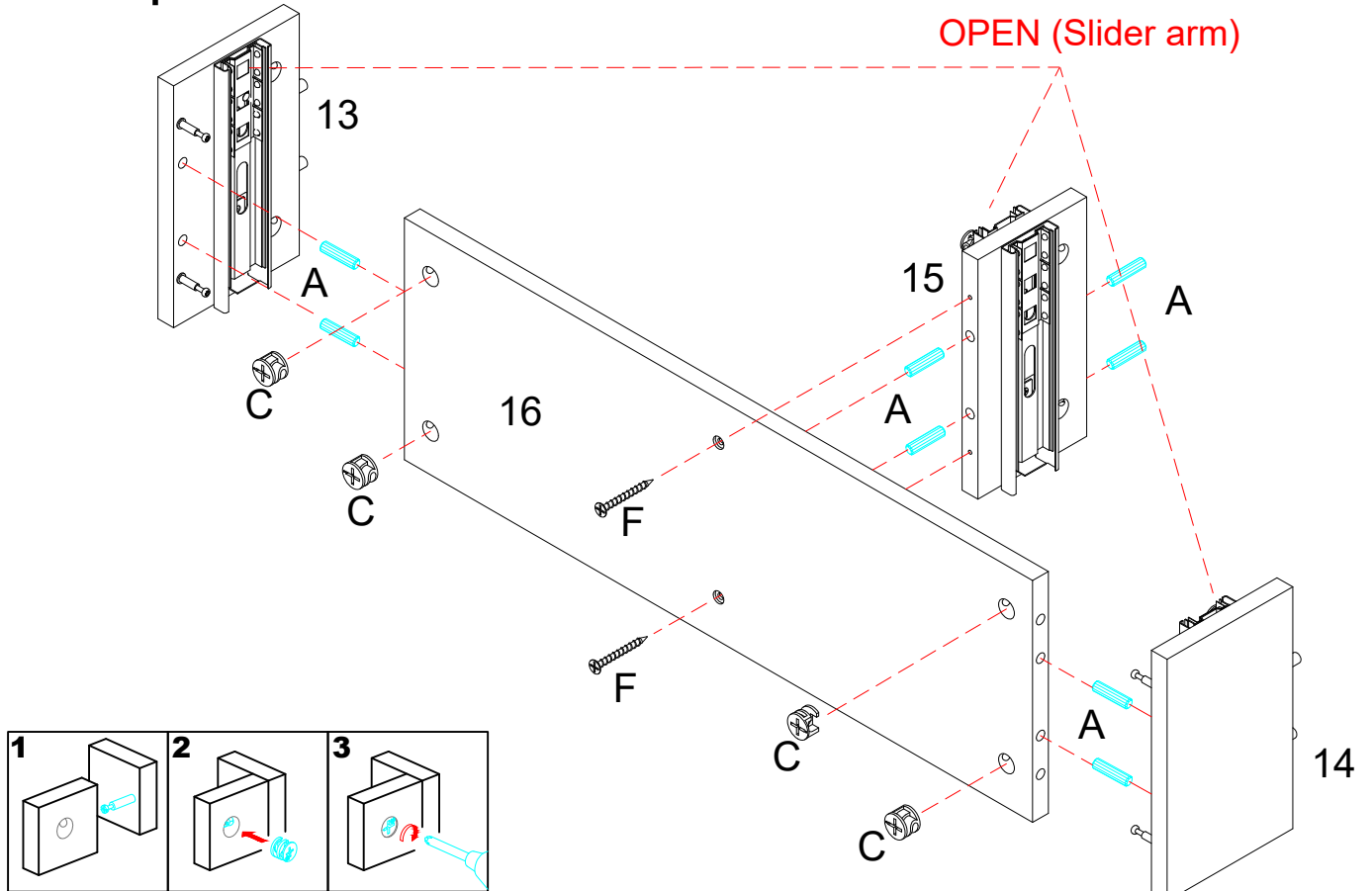

Step 35

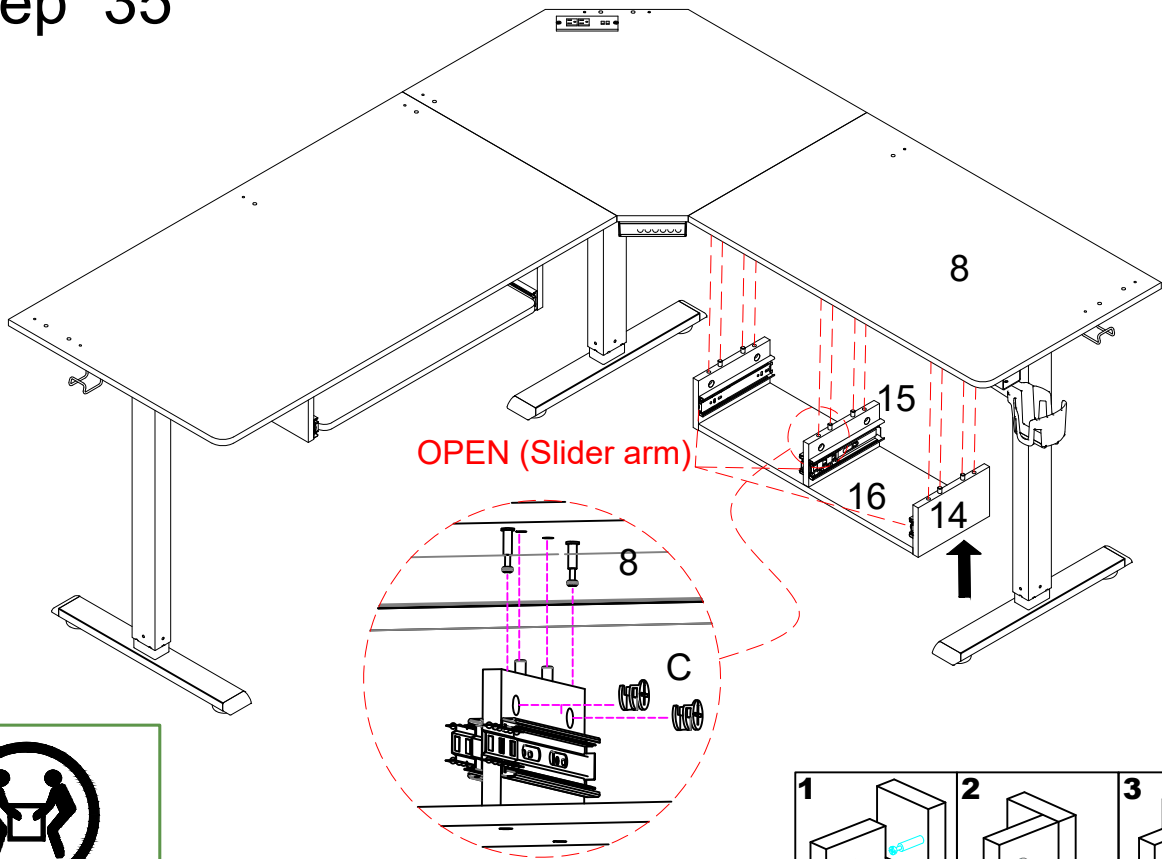

CAUTION: You may need assistance with this step.

Step 36

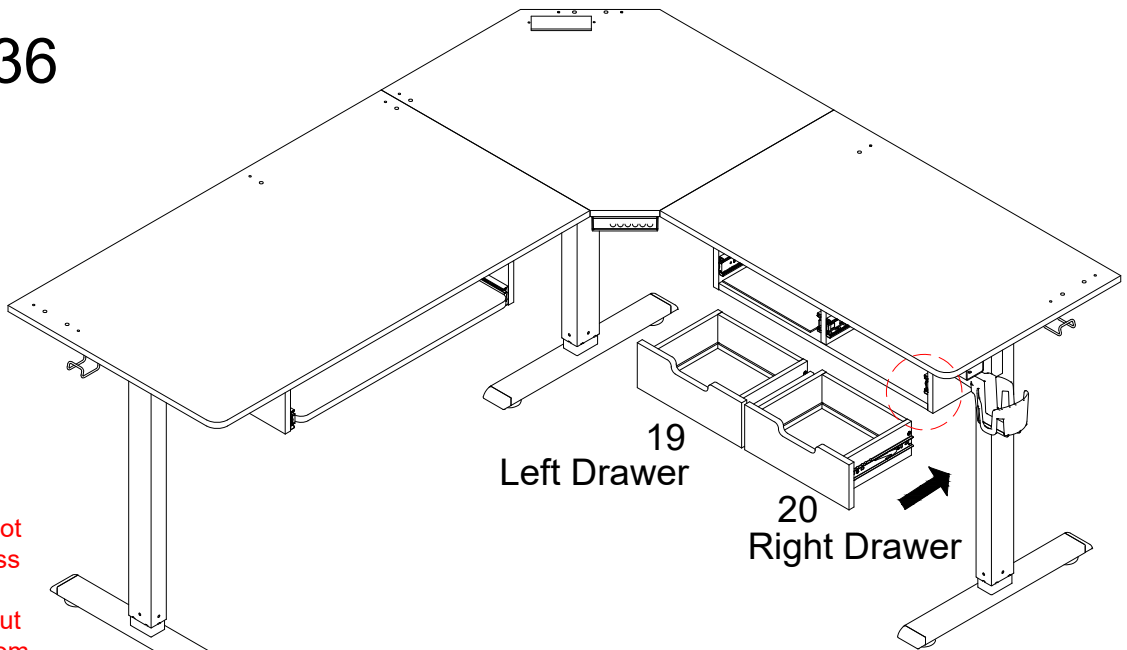

Note:
 If the drawer does not go in smoothly. Press or lift the plastic release lever. Pull out the slider bracket from the slider arm. Loosen the screws(G) on slider brackets, You can adjust up or down by a few mm. Then tighten back up. Finally re-assembled the drawer until they were going in smoothly well.

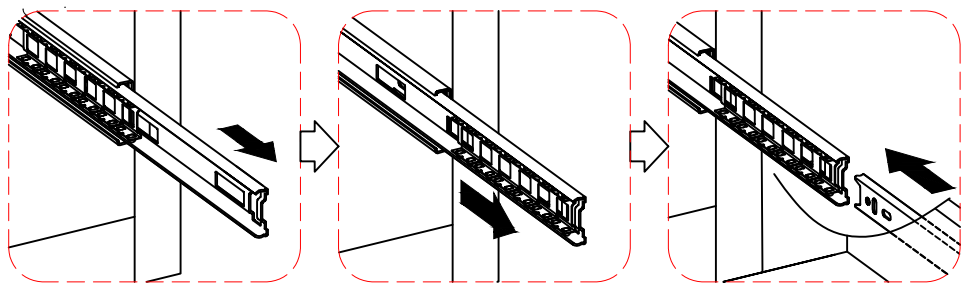

Step 37

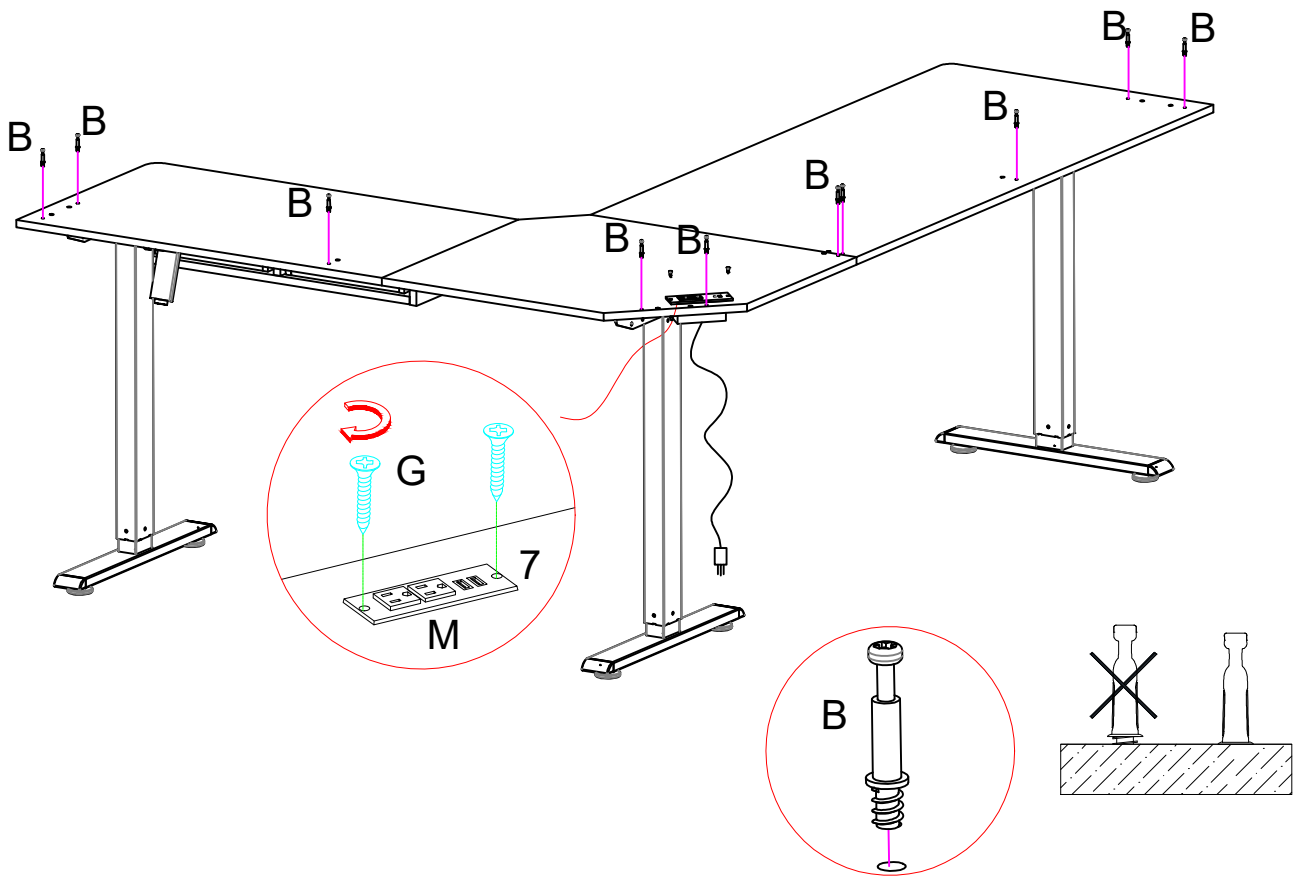

Step 38

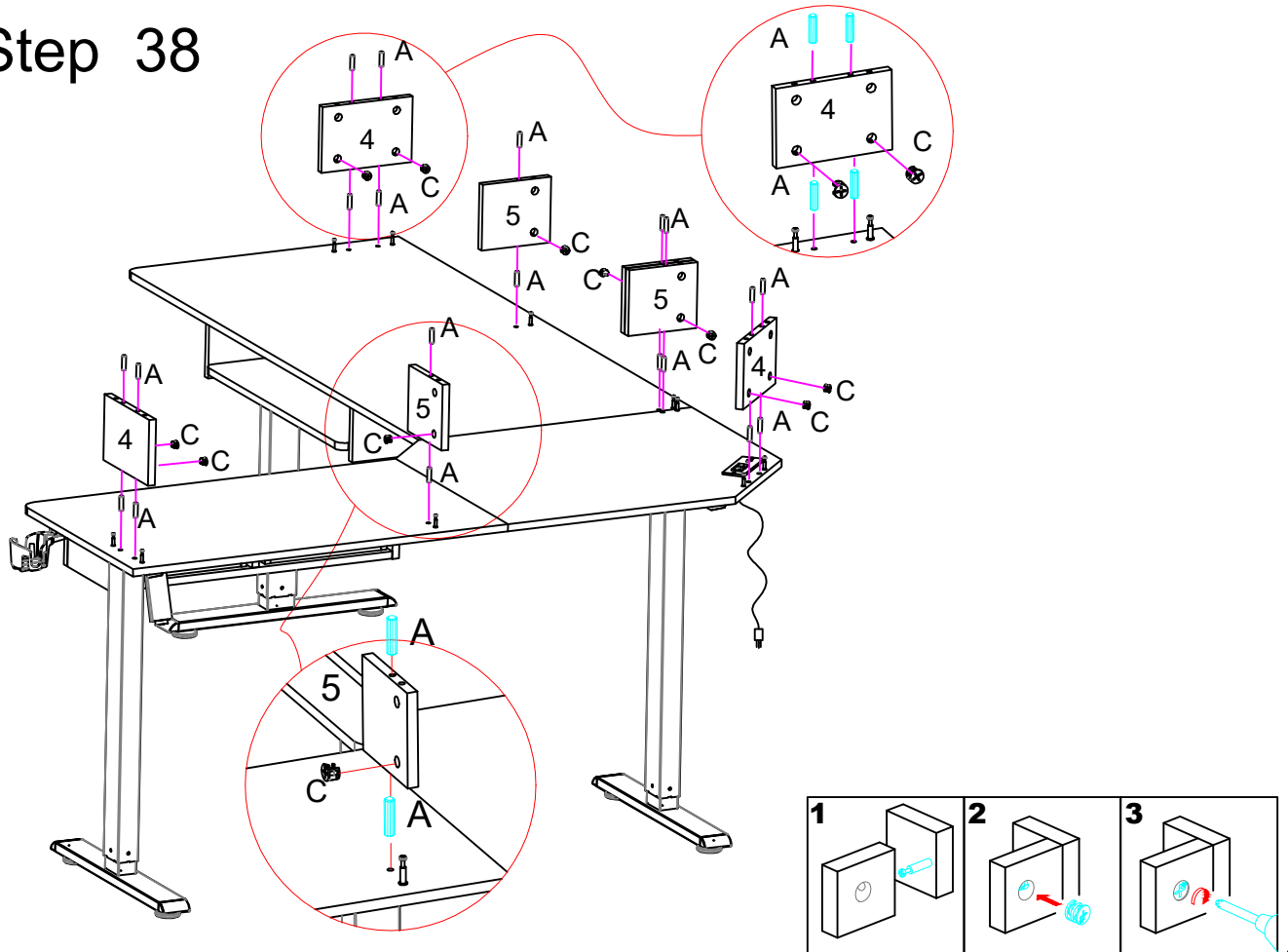

Step 39

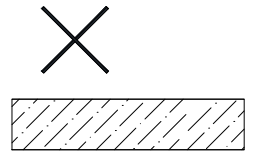
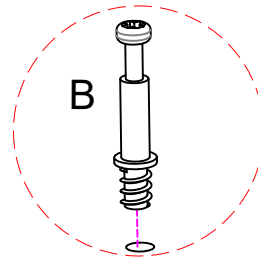
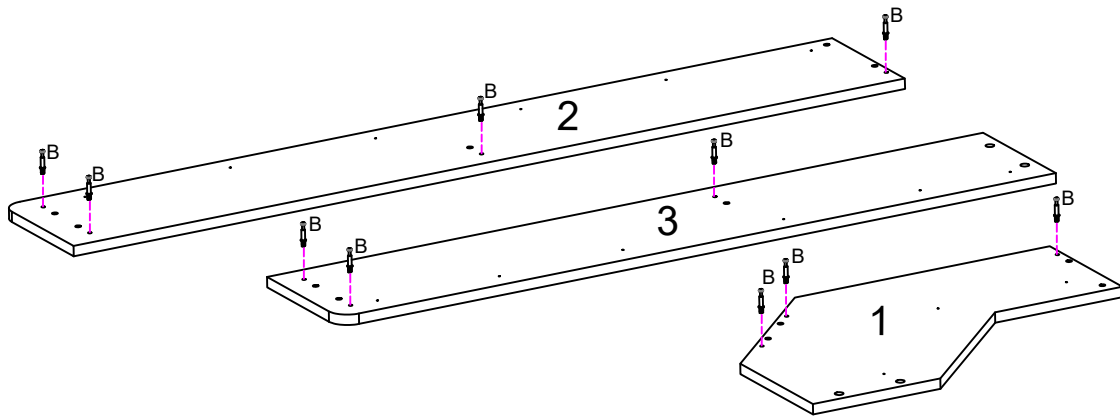

Step 40

Remove the tape

Press

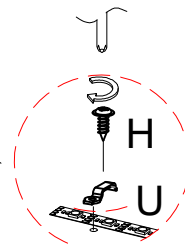
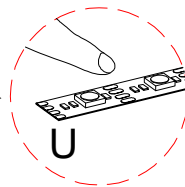
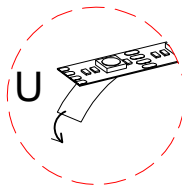
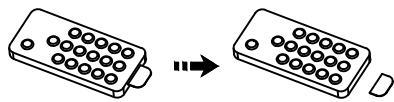

Note: Before using the remote control, pull out the plastic sheet at the bottom

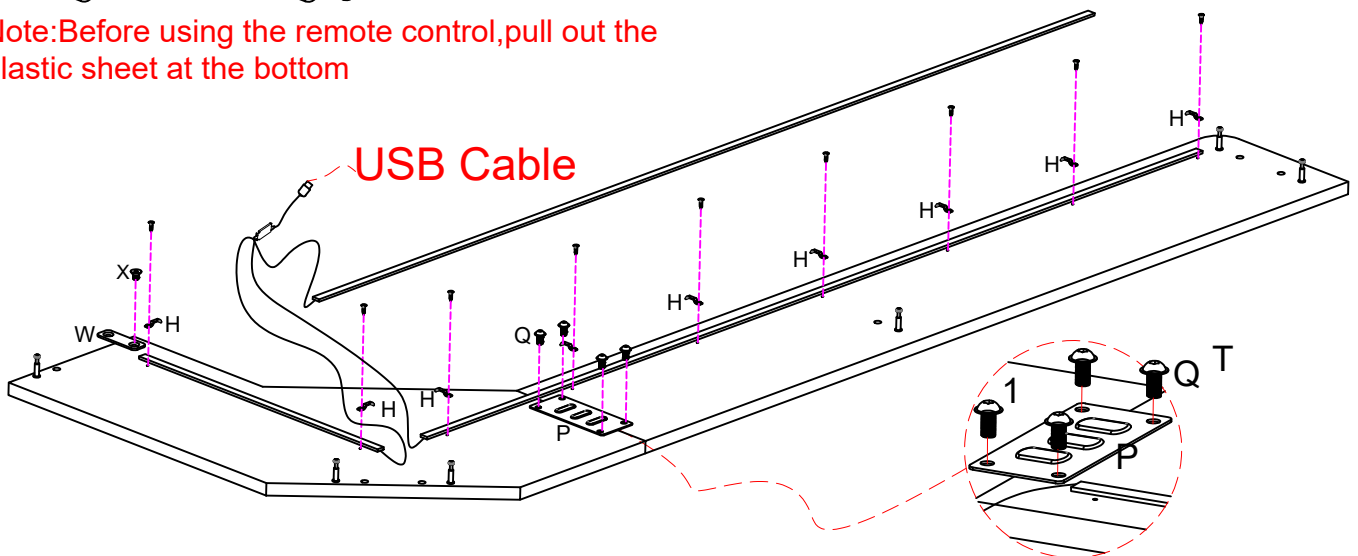

Step 41

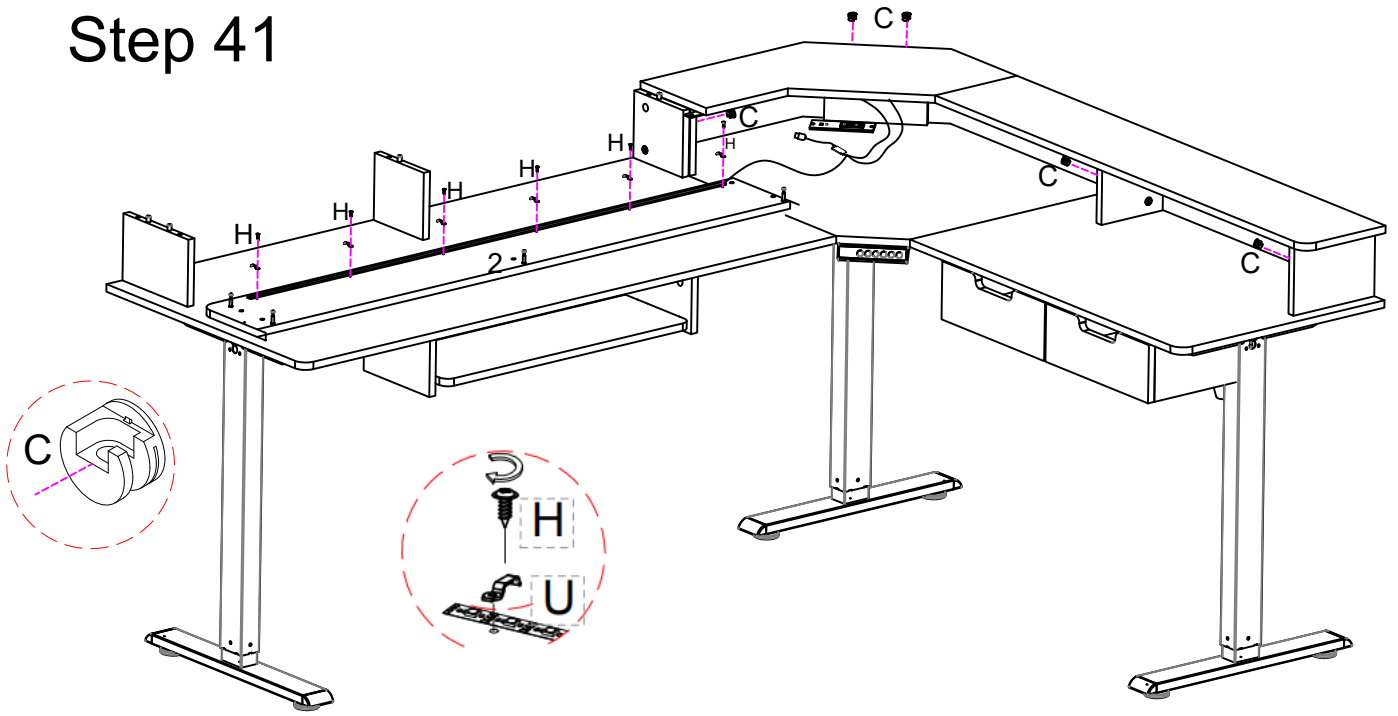

Refer to the previous step to install the led strip light to Part (3)

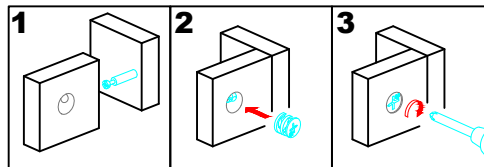

Step 42

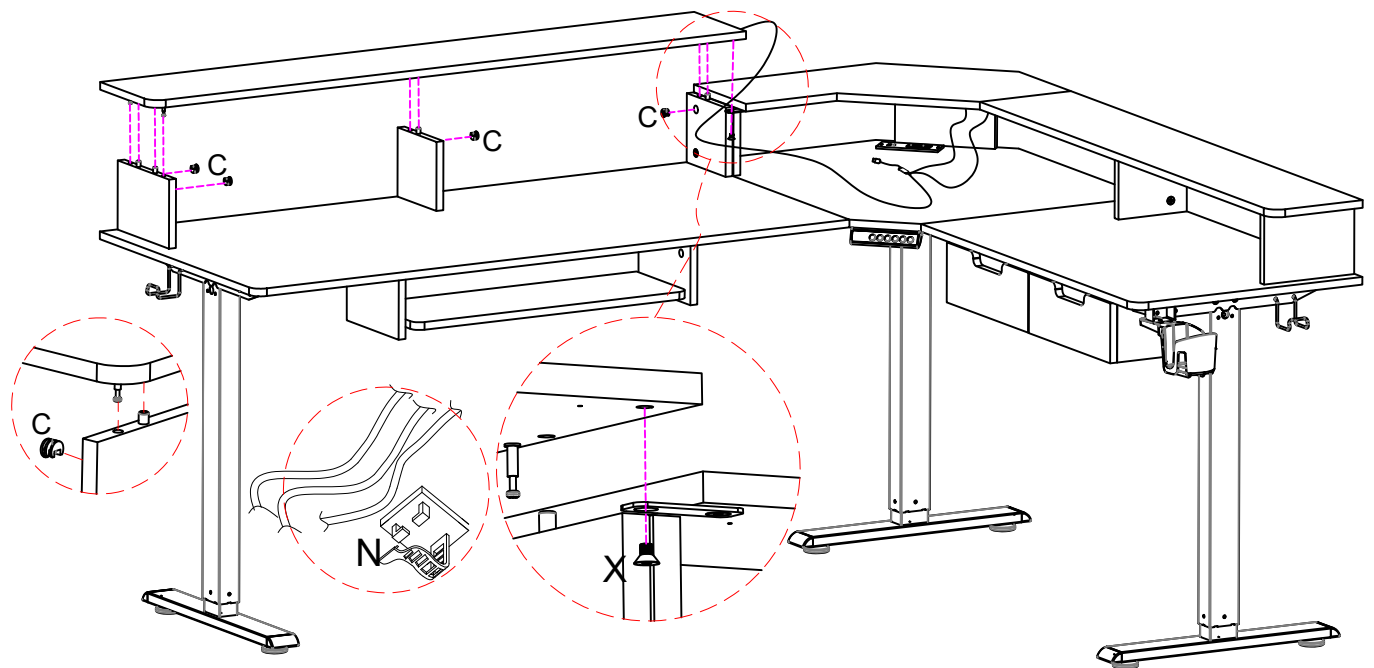

use 1pc Cable clips (N) to tie cords of led strip light

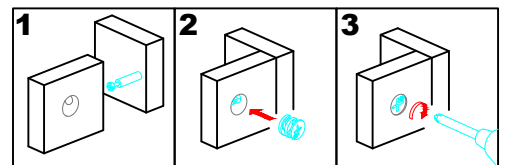

Step 43

Plug the Connector cable (L) into the Motor cable

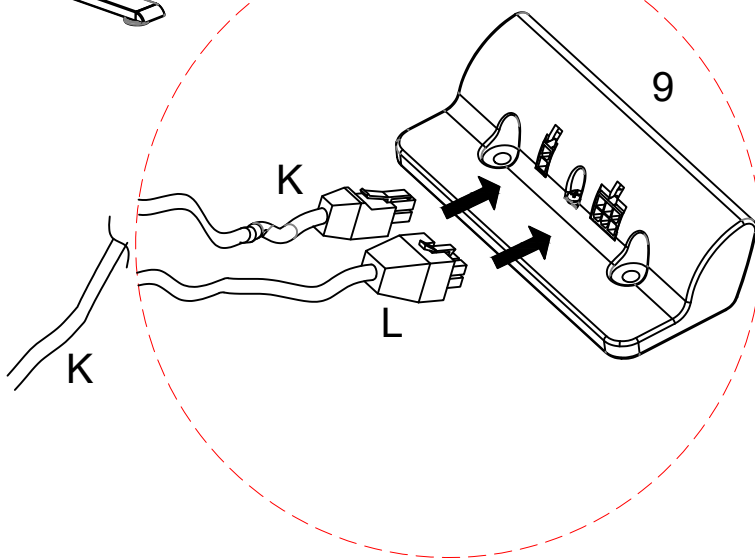
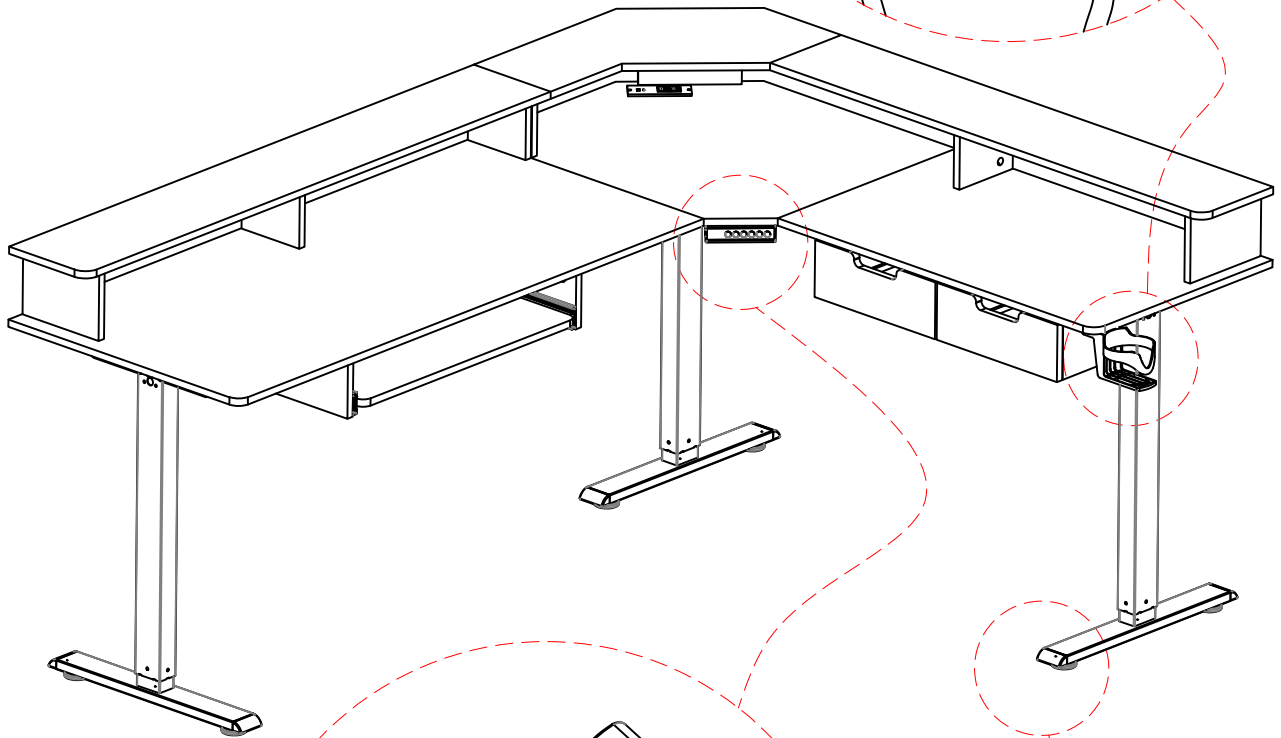
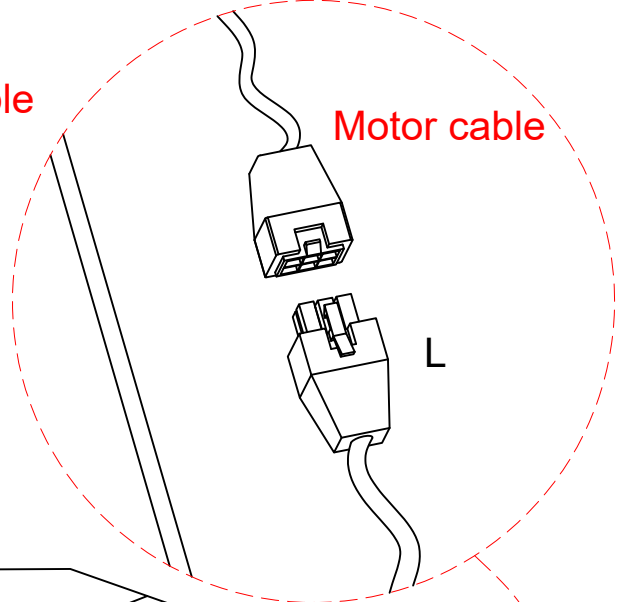

Plug the Adapter cable (K) and Connector cable (L) into the Control box (9)

If necessary adjust the floor leveler at the bottom of the leg to level the unit.

Step 44

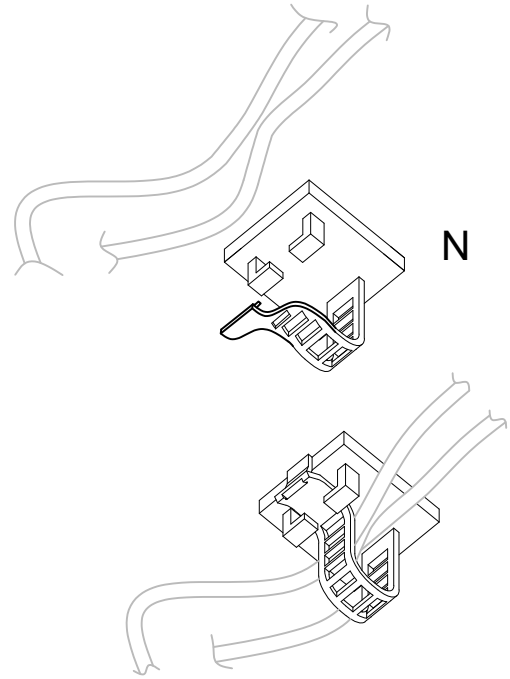
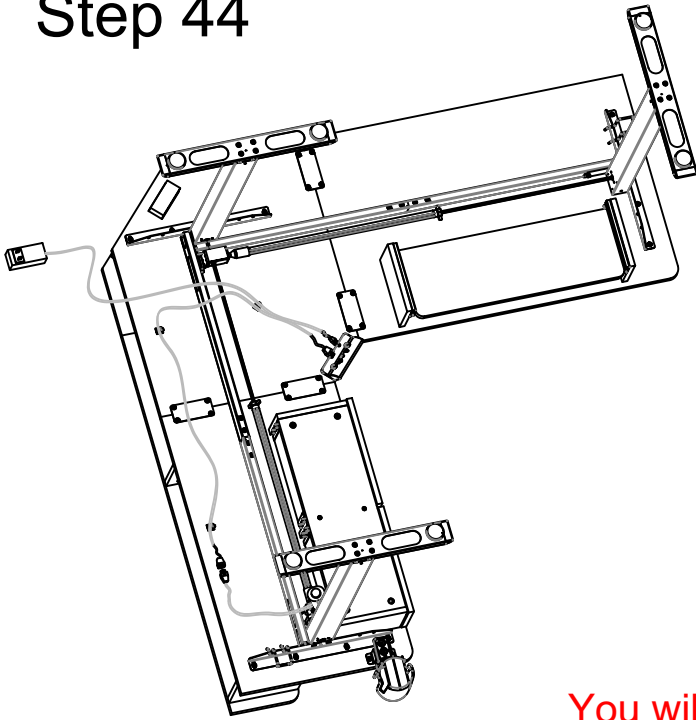

You will find that the cables all hang loose. Once everything is plugged in use the Cable clips (N) to keep them snug up against the desktop, to prevent them from getting caught on things under your desk.

Step 45

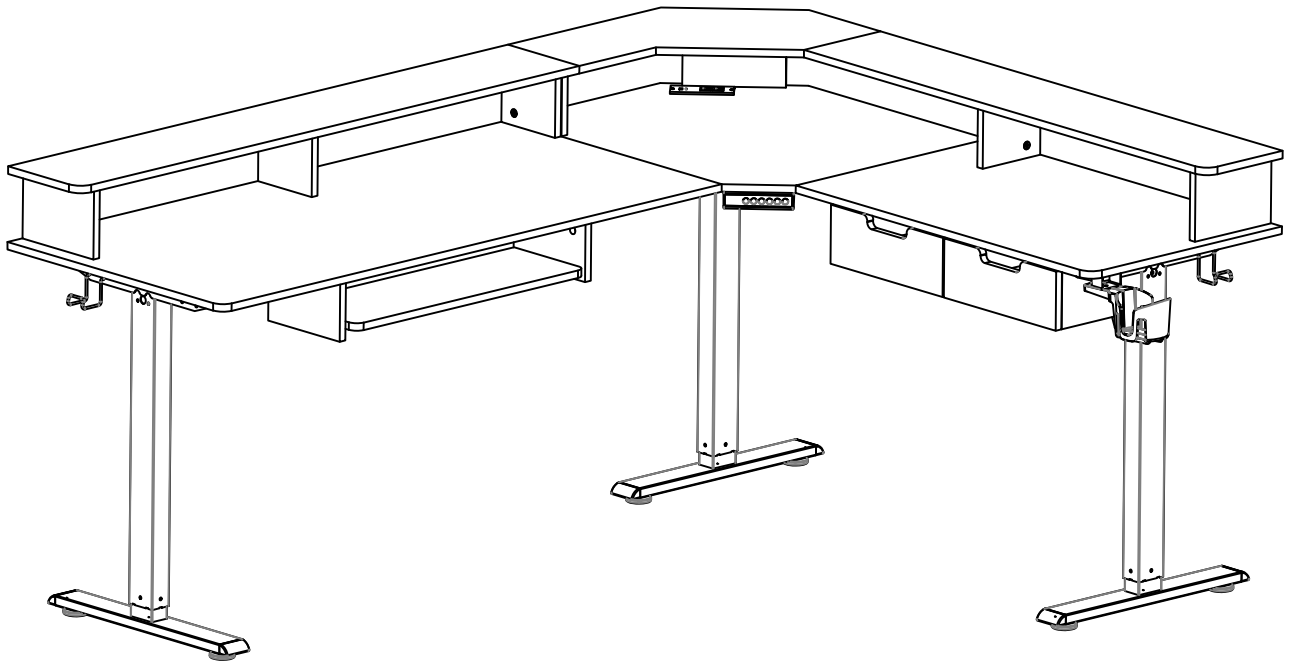

Final Assembly

Note:

Make sure cords are a length that will accommodate the change in height.

User Instructions

1. Height adjustment

Press and hold the Upper arrow to lift.The height will be show on the LED control panel

Press and hold the Down arrow to lower.The height will be show on the LED control panel

2. Save height setting.

This product provide 4 save heights for your choices .

Adjust the desk to the desired height.Press and hold the button 1or 2or 3 or 4 more than 2s.if a flashing H1orH2orH3orH4 appears on the LED control panel that means successfully save and store the desired height.

If you want to change the save height just repeat this step .the new save height would cover the last setting.

3. Parameter setting

Press and hold the 1&2 button at the same time on the LED control panel

,it will be flashing with the position (off ,L (light) N(normal),H(heavy)).

4.Error code

Code	Problem	Action
E02	Desk sloping	Make sure desk is evenly and reset the desk
Hot	Over heat	Power off and power on after at least 15mins
E10	Motor fault	Power off and check the cables and control systems. and then power on ,or reset the motor (see below section 5) or check the installation from step6 to step11 .if issue persists,contact the customer service.
E20	Over load	Remove some weight on the top panel until the error clears
E31	Lower voltage	Power off and check the cables and control systems. and then power on
E32	Height voltage	Power off and check the cables and control systems. and then power on ,if issue persists,contact the customer service.

5 Initialize and reset

When the error code“E10”“E20”appears on LED control panel or the desk at the lowest

position,Press and hold the down arrow for more than 3s , if flashing RES on the LED control

panel ,Release the button ,the desk will move downward to the end and rebound for a few distance that means successfully reset the lowest position.