

# ASSEMBLY INSTRUCTION

## STORAGE BENCH

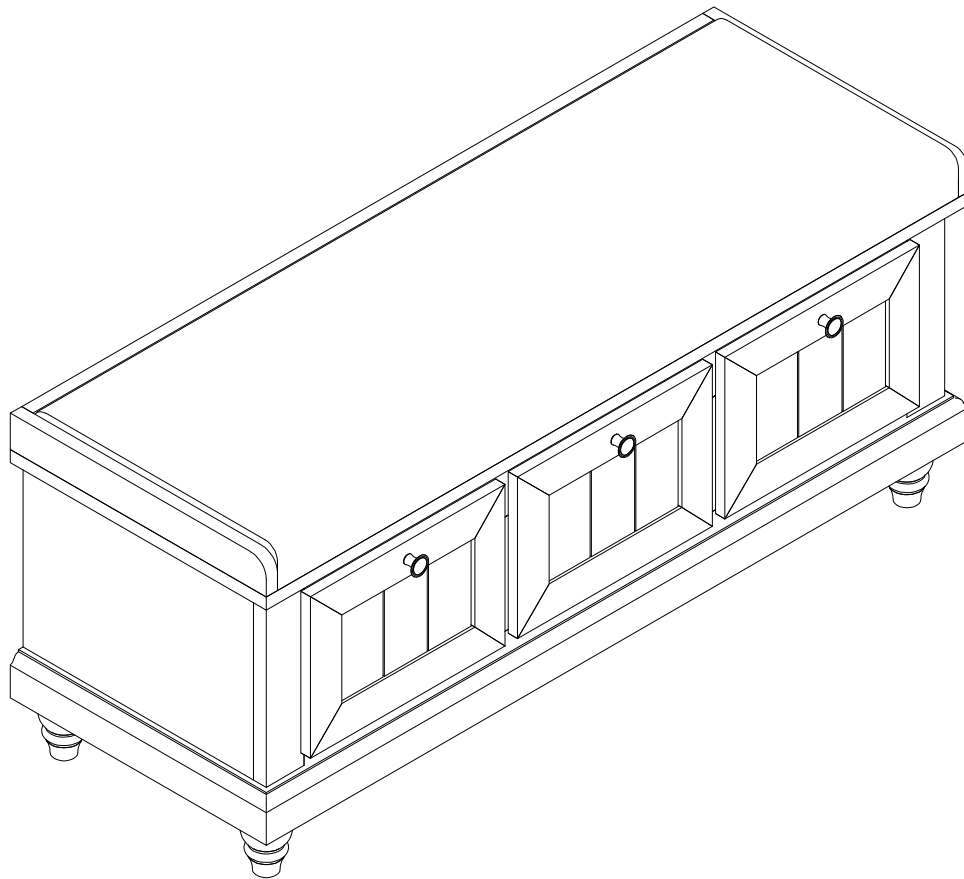

**IMPORTANT NOTE :**

- ① PLACE ALL PARTS ON A CLEAN AND SMOOTH SURFACE SUCH AS A RUG OR CARPET TO AVOID THE PARTS FROM BEING SCRATCHED.
- ② BEFORE YOU BEGIN , KINDLY FOLLOW THE ASSEMBLY INSTRUCTIONS STEP BY STEP.
- ③ DO NOT TIGHTEN ALL SCREWS AND BOLTS UNTIL THE TABLE IS FULLY SET-UP

## Detail View

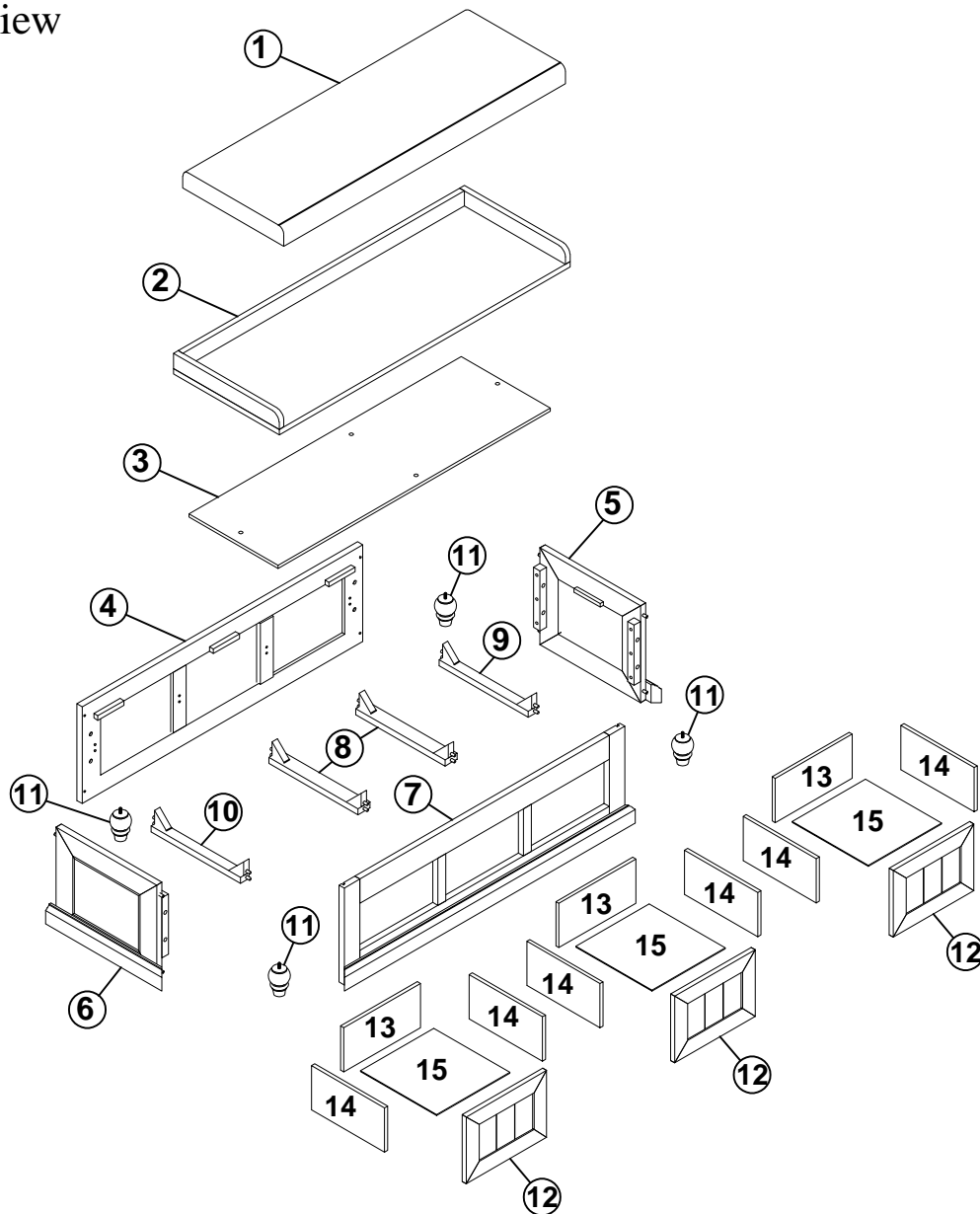





Please read these instructions fully before starting assembly:

1. Check you have all the components and tools listed on the following pages.
2. Remove all fittings from the plastic bags and separate them into their groups.
3. Keep children and animals away from the work area, small parts could choke if swallowed.
4. Make sure you have enough space to layout the parts before starting.
5. During assembly do not stand or put weight on the product, this could cause damage.
6. Assemble the item as close to its final position (in the same room) as possible.
7. Assemble on a soft level surface to avoid damaging the unit or your floor.
8. Parts of the assembly will be easier with 2 people.
9. To reduce the likelihood of damaging your product please ensure that your power drill is set on a low torque setting.
10. Assemble all parts and bolts loosely during assembly, only once the product is complete should you fully tighten the bolts
11. Regularly check and ensure That all bolts and fittings are tightend properly.
12. Please do not place items that exceed the load capacity.



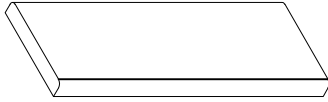
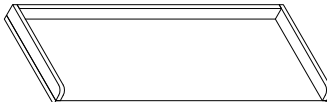

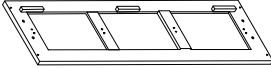
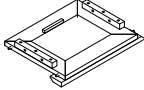
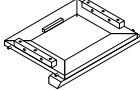
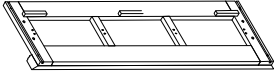
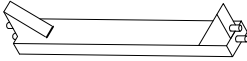
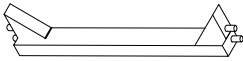
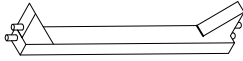

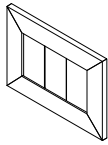
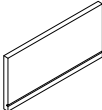
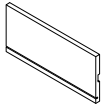
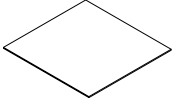
Care and maintenance:

Only clean using a damp cloth and mild detergent, do no use bleach or abrasive cleaners.

## PART LIST

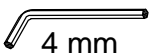

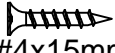
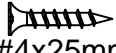

<b>1</b>  CUSHION(1pc)	<b>2</b>  TOP FRAME(1pc)
<b>3</b>  BOTTOM SHEF (1pc)	<b>4</b>  BACK FRAME (1pc)
<b>5</b>  RIGHT SIDE FRAME (1pc)	<b>6</b>  LEFT SIDE FRAME (1pc)
<b>7</b>  FRONT FRAME(1pc)	<b>8</b>  CENTER SUPPORT DRAWRE (2pcs)
<b>9</b>  LEFT SUPPORT DRAWRE (1pc)	<b>10</b>  RIGHT SUPPORT DRAWRE (1pc)
<b>11</b>  LEGS (4pcs)	<b>12</b>  FRONT DRAWER (3pcs)
<b>13</b>  BACK DRAWER (3pcs)	<b>14</b>  SIDE DRAWER (6pcs)
<b>15</b>  BOTTOM DRAWER (3pcs)	

## HARDWARE LIST

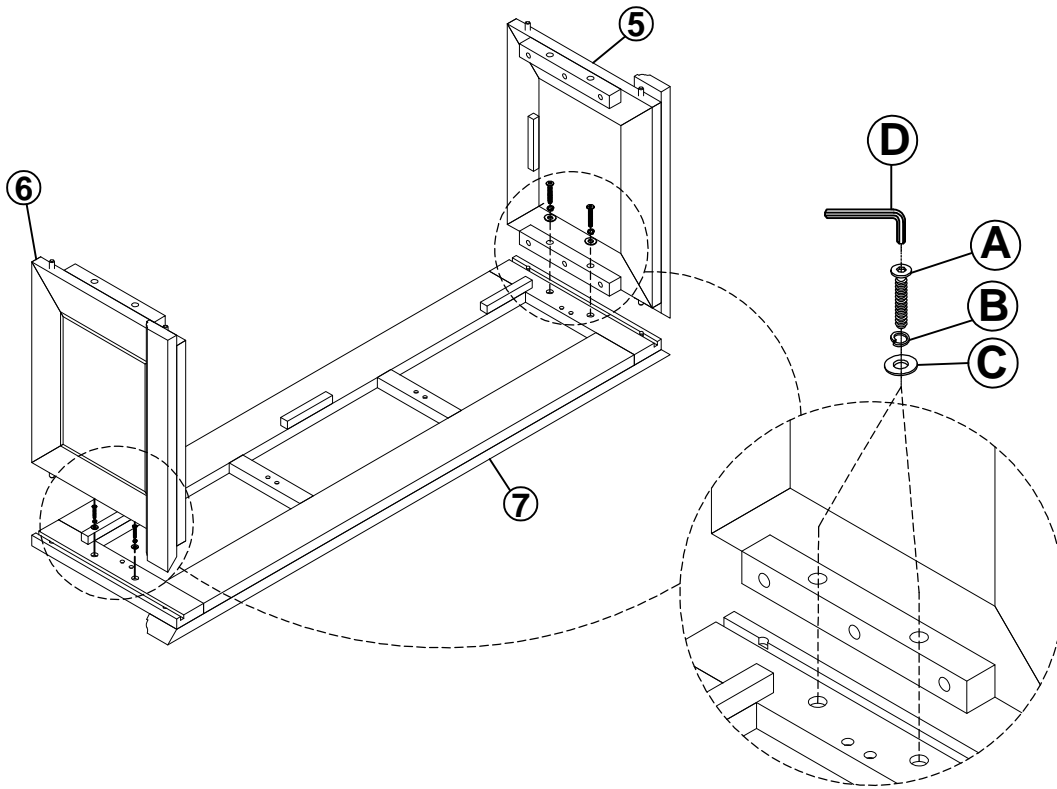
<b>A</b>  Ø1/4" x 35mm BOLT (8pcs)	<b>B</b>  Ø1/4"x11mm SPRING WASHER (8pcs)	<b>C</b>  Ø1/4"x19mm FLAT WASHER (8pcs)	<b>D</b>  4 mm ALLENKEY (1pc)
<b>E</b>  HOLES (2pcs)	<b>F</b>  FOLDED (1pc)	<b>G</b>  #4x15mm WOOD SCREW (20pcs)	<b>H</b>  #4x25mm WOOD SCREW (48pcs)
<b>I</b>  HANDLE (3pcs)	<b>J</b> Ø5/32x28mm  HANDLE BOLT (3pcs)		

# Step 1





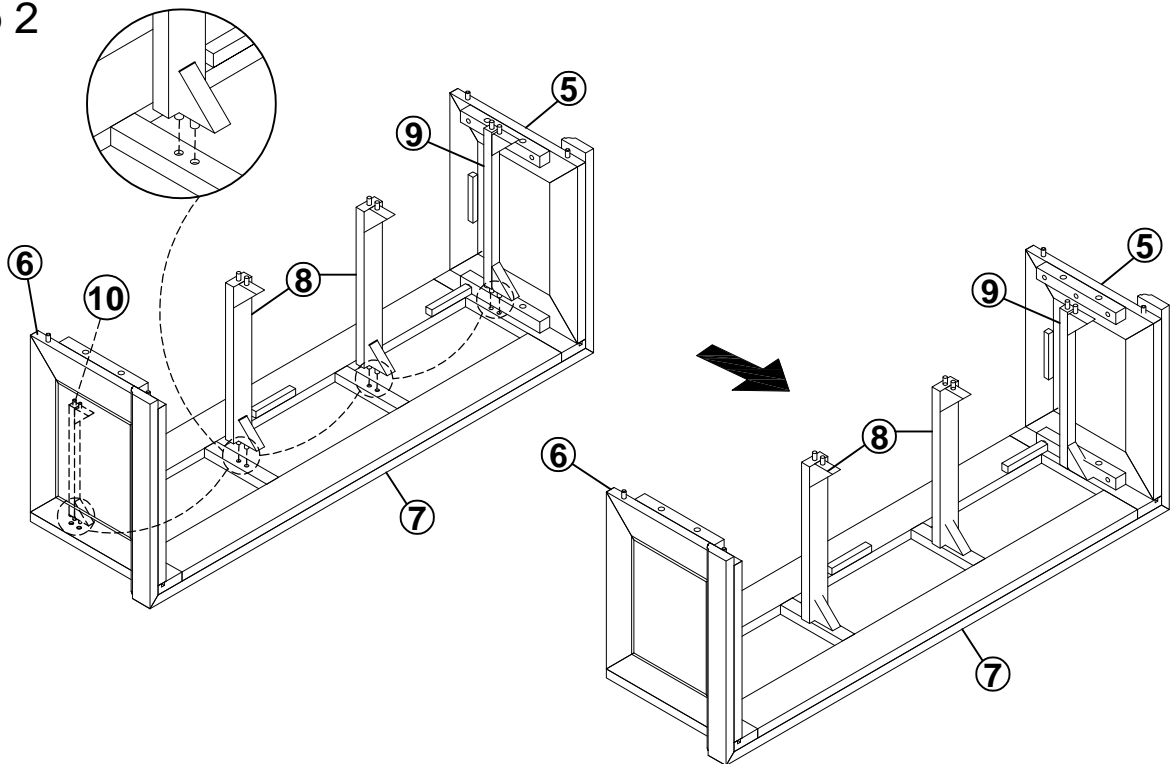

A	Ø1/4"x35		4PCS	C	Ø1/4"x19		4PCS
B	Ø1/4"x11		4PCS	D	4x58mm		1PC

# Step 2

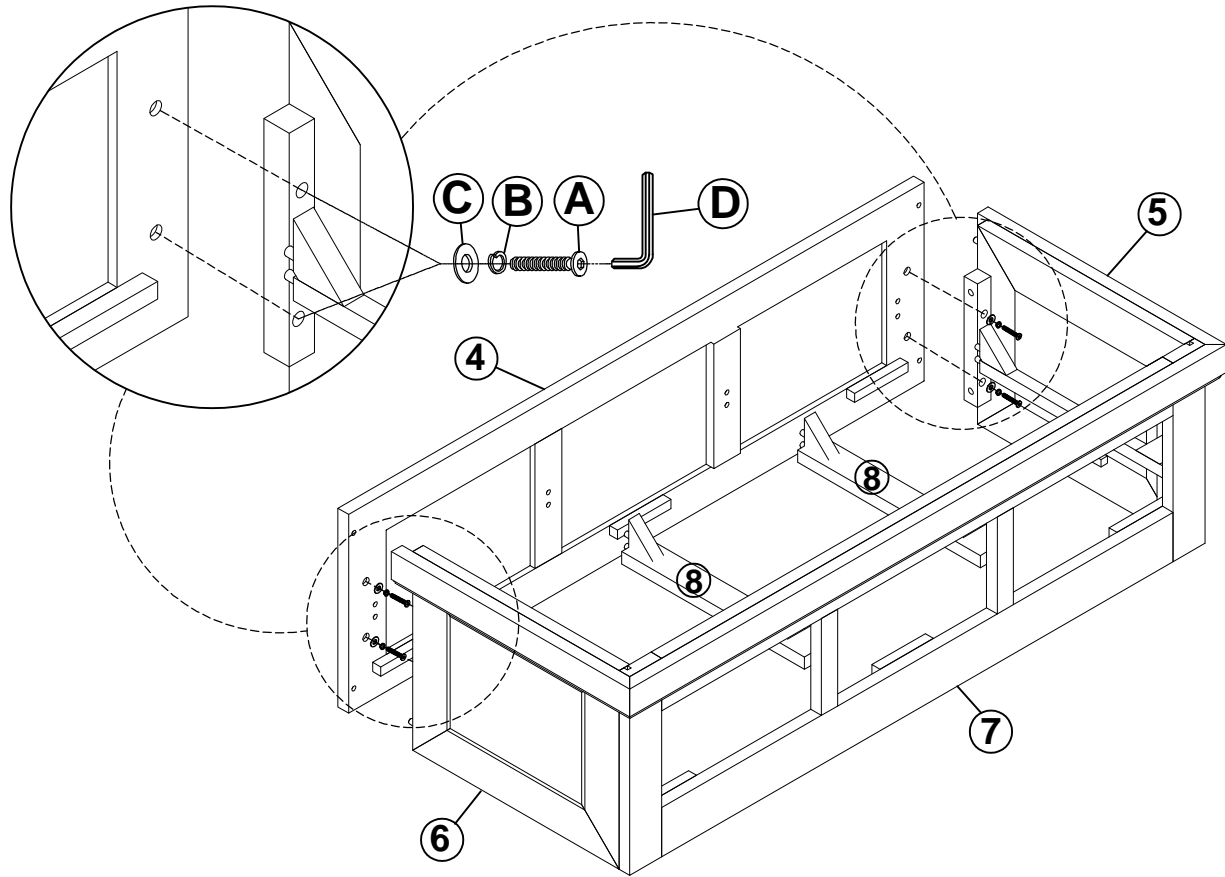

### Step 3



A	Ø1/4"x35		4PCS	C	Ø1/4"x19		4PCS
B	Ø1/4"x11		4PCS	D	4x58mm		1PC

### Step 4

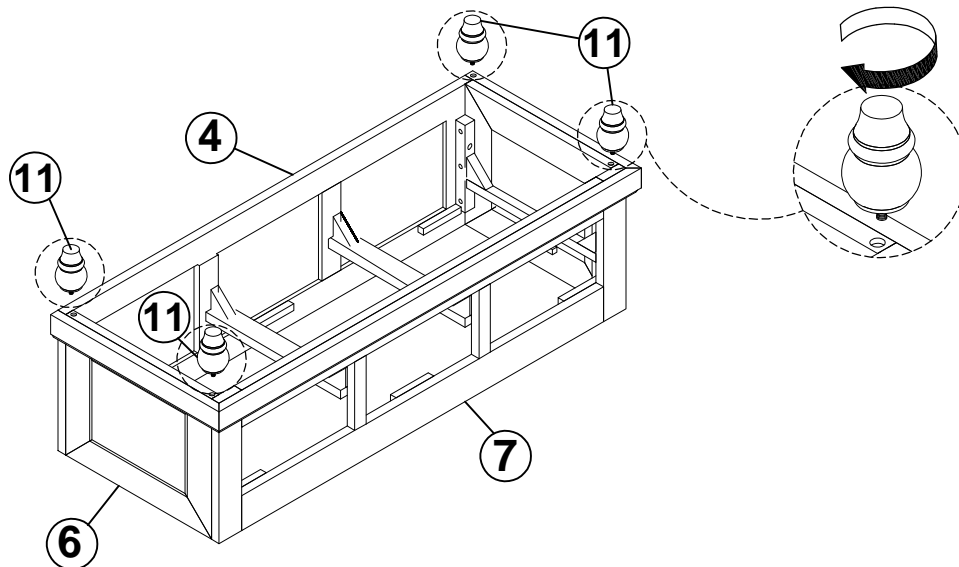

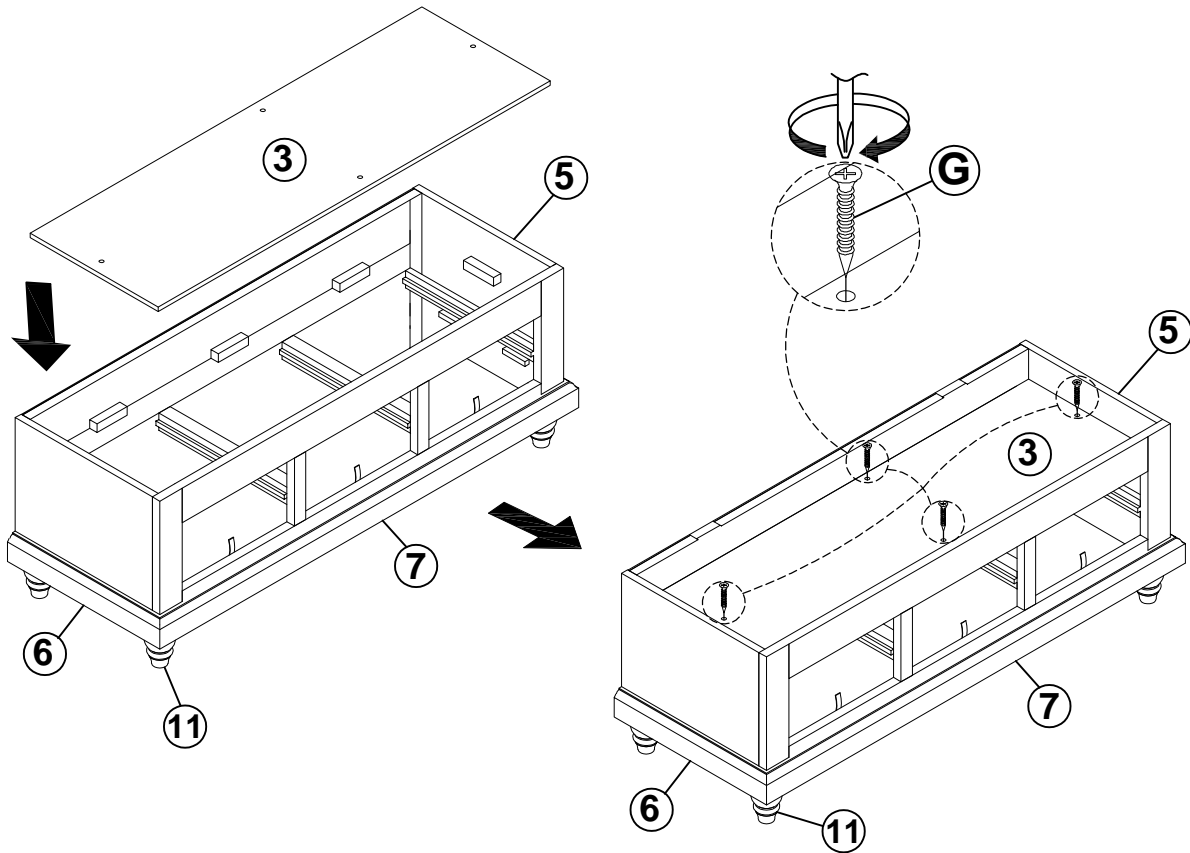

# Step 5

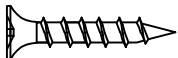

G	#4x15mm		4PCS
---	---------	---	------

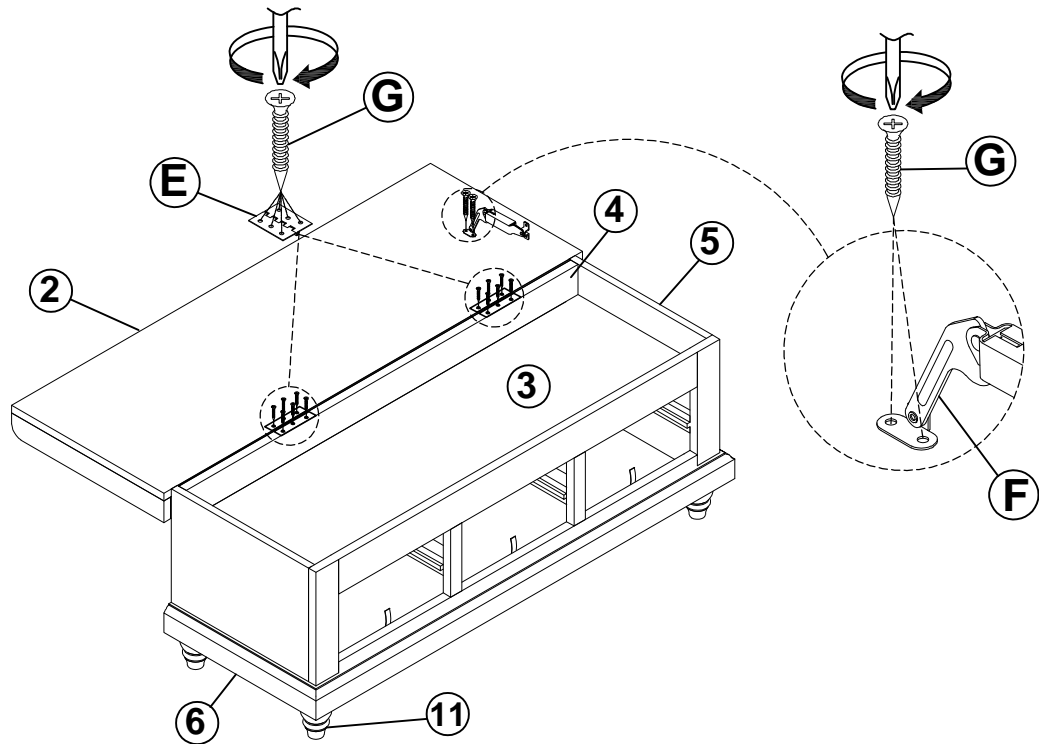

# Step 7

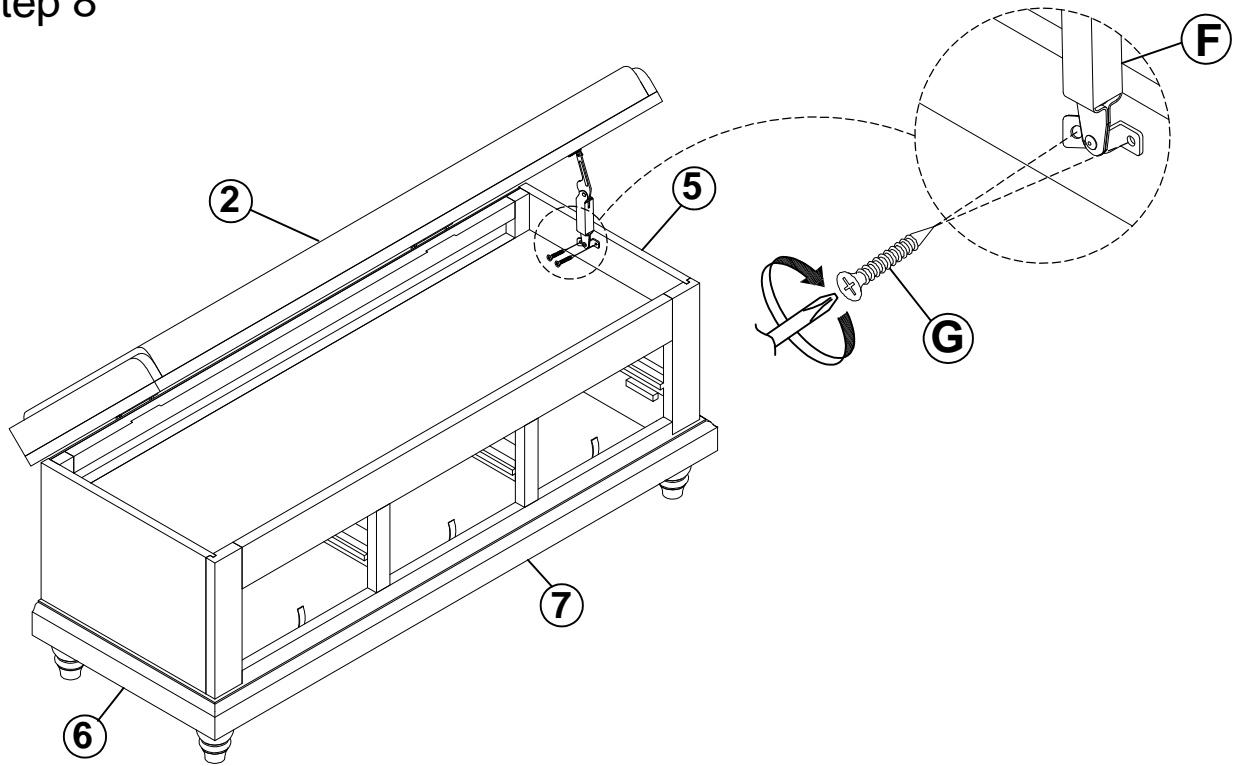

G	#4x15mm		14PCS	E		2PCS
---	---------	---	-------	---	---	------

### Step 8



G	#4x15mm		2PCS	F		1PC
---	---------	--	------	---	---	-----

### Step 9

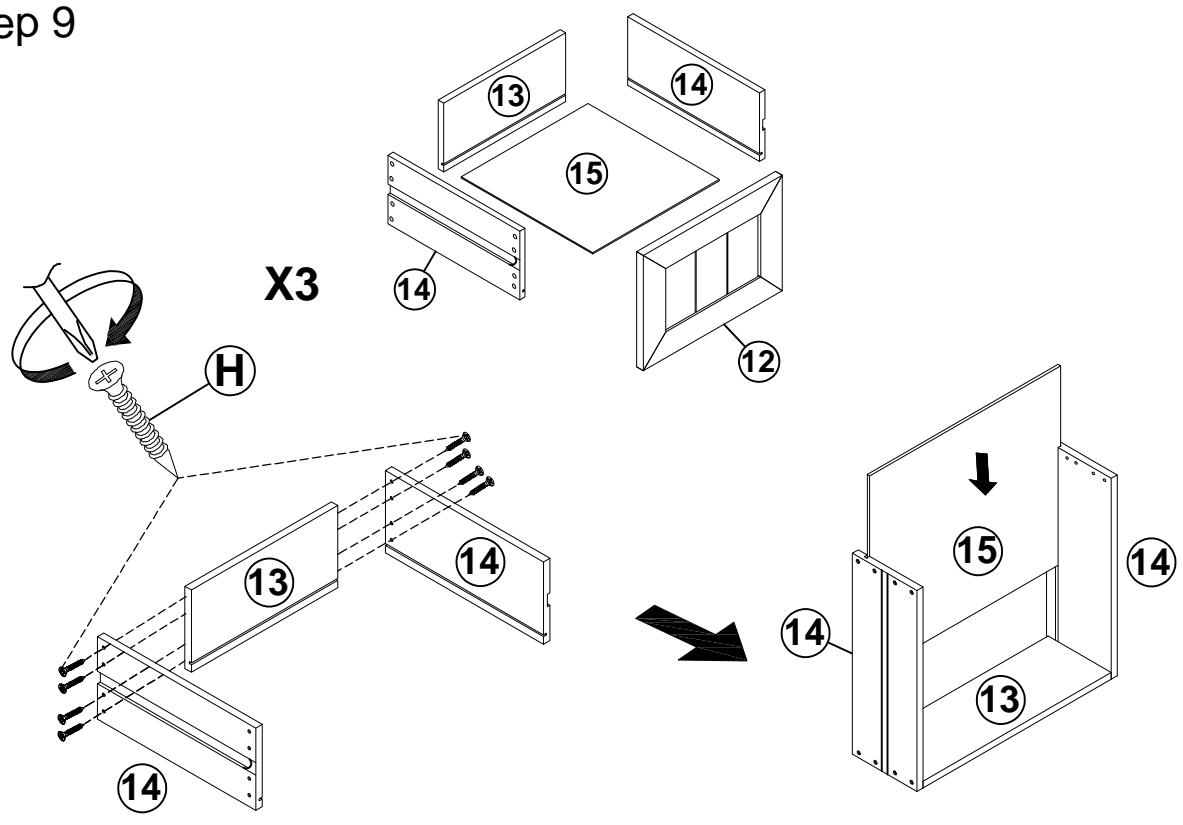

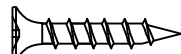
H	#4x25mm		24PCS			
---	---------	---	-------	--	--	--

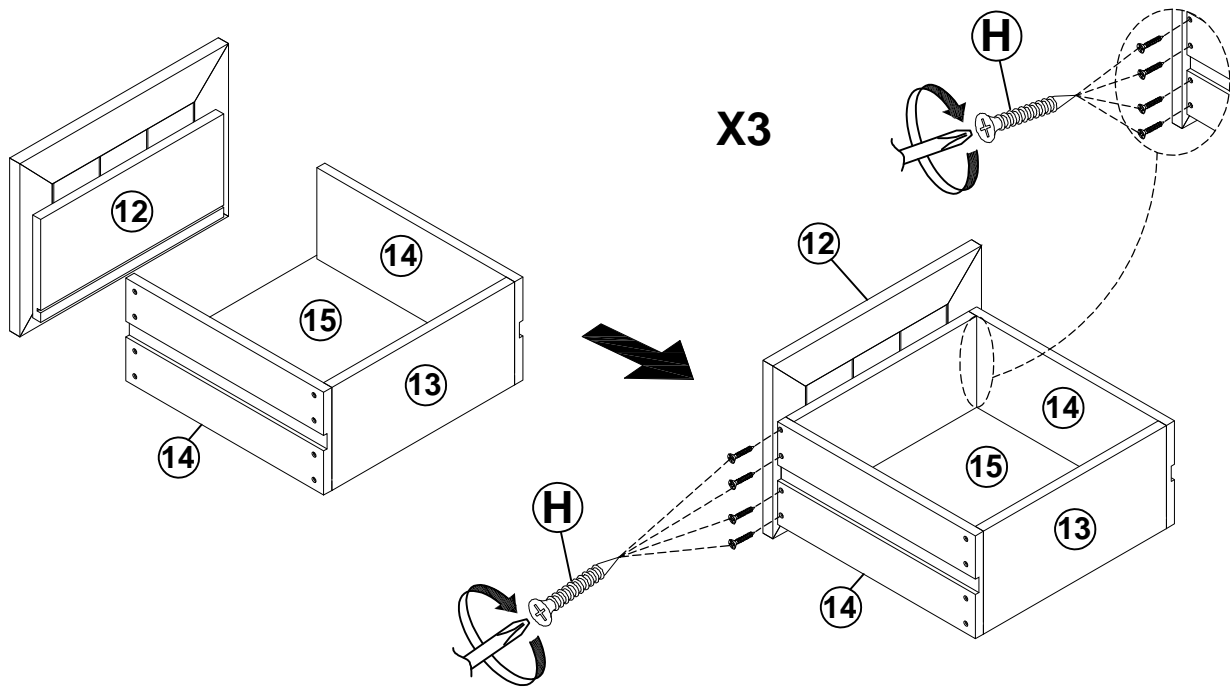

# Step 10

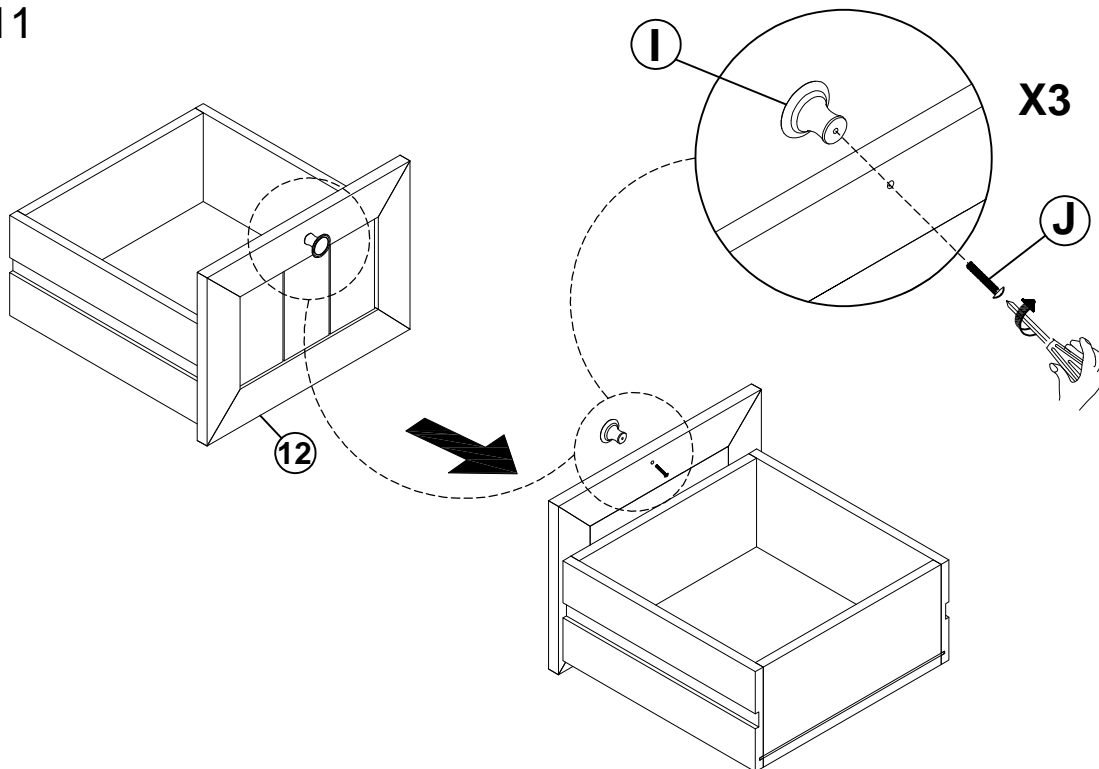

H	#4x25mm		24PCS	
---	---------	---	-------	--

# Step 11



I		3PCS	J	Ø5/32x28mm 	3PCS
---	---	------	---	--	------

# Step 12

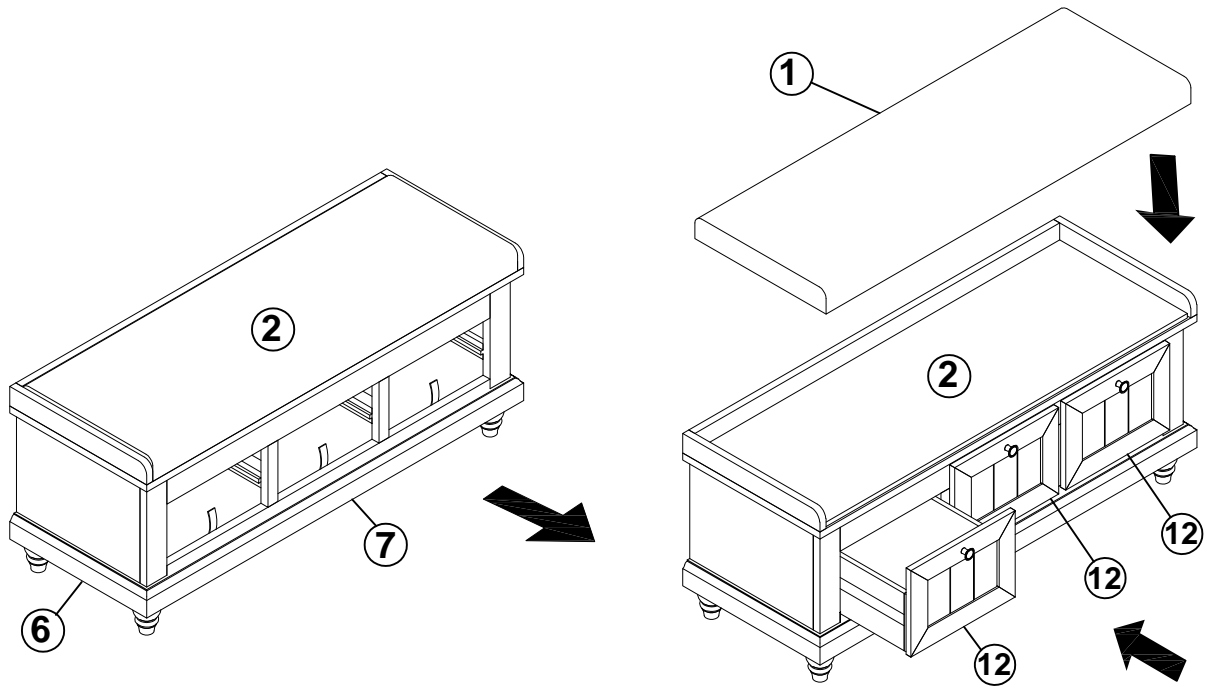

# Complete

