

# ASSEMBLY INSTRUCTIONS

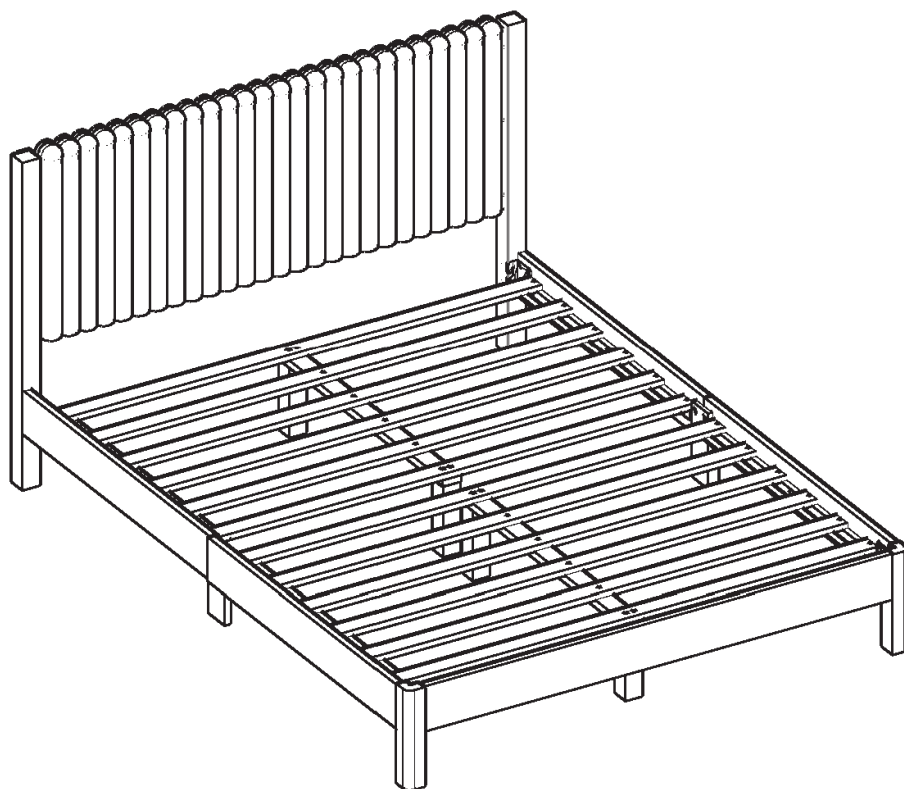

## TOOLS REQUIRED

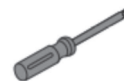

Screwdriver  
( Not included)



(Included)  
Allen Wrench



2 - People

## ASSEMBLY RATING



EASY —————> DIFFICULT

The Assembly Rating is a 5-point system showing the level of effort needed to assemble a specific product.



## **CHECK BEFORE STARTING**

### **Are you missing anything?**

Double-check all parts, hardware and accessories listed are all accounted for.

### **Check out our Quick Tips!**

We recommend reviewing the pre-assembly handouts. Even experts need a refresher now and then!

### **Should we send any replacements?**

Are there any irregularities or flaws in the parts? We can send replacements!

### **Prep Time!**

Please review the assembly instructions and all diagrams prior to assembling.

# PRE ASSEMBLY INTRODUCTION

We understand building ready-to-assemble furniture can be a challenging experience for some. To help avoid confusion, we have provided some helpful tips that may speed up the process.



## Teamwork

ALWAYS have at least two people to help with transporting and assembling the product to avoid potential injury and/or damage.



## Suitable Location

Assembling near the area of the intended location is highly recommended.



## Sufficient Space

Make sure you have enough space to move around during the assembly.



## Avoid Scratches

Use cardboard, blankets or a carpeted area while assembling furniture to prevent to prevent scratches and damages.



## Flat Surface

Make sure the furniture rests on a flat and level surface with each leg evenly touching the floor.

# ASSEMBLY AND CARE ADVICE



**FAILURE TO FOLLOW THE GUIDELINES BELOW MAY RESULT IN INJURY AND/OR PROPERTY DAMAGE.**



Position each part correctly and insert screws or bolts into their respective holes.



Turn clockwise to tighten and only tighten when step is completed or when instructed to do so.



Use the appropriate hand tools or power tools for assembly. Select steps, such as tightening screws and/or bolts, may require hand tools to avoid causing damage during assembly.



Save the instructions and store any supplied tools for later maintenance.



After two weeks, check and tighten any loose hardware and repeat again every six months thereafter.

**IT IS THE USER'S RESPONSIBILITY TO MAINTAIN THE FURNITURE. THE HARDWARE MAY LOOSEN OVER TIME AND MAY CAUSE THE FURNITURE TO BE WOBBLY AND UNABLE TO SUPPORT ITS INTENDED WEIGHT CAPACITY. THIS MAY LEAD TO COLLAPSE AND MAY CAUSE SERIOUS INJURY.**

# BED

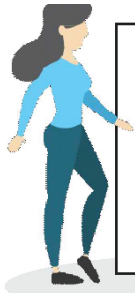

- Please keep instructions for future reference.
- Check the quantity and irregularity of parts and hardware before you start.

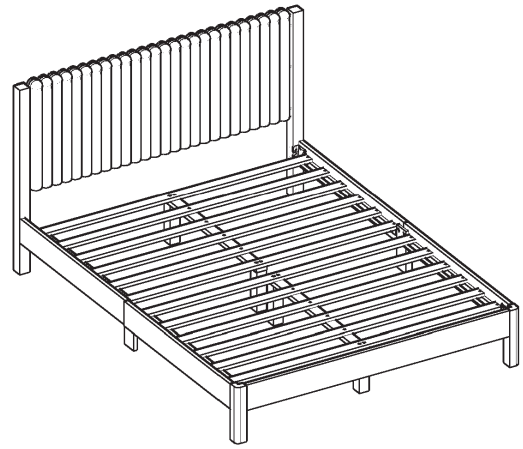

## PARTS

1

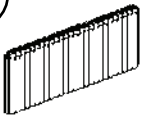

Headboard  
1 pc.

2L



Headboard Leg (Left)  
1 pc.

2R



Headboard Leg (Right)  
1 pc.

3L



Footboard Leg (Left)  
1 pc.

3R

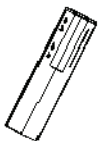

Footboard Leg (Right)  
1 pc.

4L

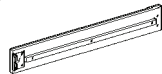

Side Rail  
1 pc.

4R



Side Rail  
1 pc.

5L



Side Rail  
1 pc.

5R



Side Rail  
1 pc.

6



Footboard  
1 pc.

7



Center Rail  
2 pcs.

8



Center Leg  
4 pcs.

9



Side Rail Leg  
2 pcs.

10

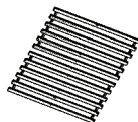

Slat  
12 pcs (2set)

## HARDWARE

A



Allen Key M4  
(Long Ball Head)  
1 pc.

B



Allen Key M5  
1 pc.

C

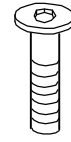

JCBC Bolt  
M6 x 50mm  
8 pcs.

D

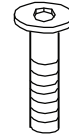

JCBC Bolt  
M6 x 40mm  
4 pcs.

E

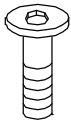

JCBC Bolt  
M6 x 45mm  
4 pcs.

F

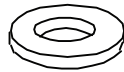

M6 Flat  
Washer  
4 pcs.

G



M6 Spring  
Washer  
8 pcs.

H



Wood Dowel  
M8 x 32mm  
4 pcs.

I

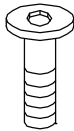

JCBC Bolt  
M6 x 25mm  
8 pcs.

J

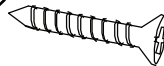

Wood Screw  
M4 x 25mm  
32 pcs.

# ASSEMBLY INSTRUCTIONS

1

- I. Attach the Headboard Legs (#2R, 2L) to Headboard (#1) using Bolt (#D) with Spring Washer (#G) and Flat Washer (#F).
- II. Align the Footboard Legs (#3R, 3L) with the Footboard (#6), ensuring the arrow points upward (see diagram). First, interlock with Wood Dowels (#H). Then secure with Bolt (#E) and Spring Washer (#G).

Part #1 x 1pc  
Part #2L x 1pc  
Part #2R x 1pc  
Part #3L x 1pc  
Part #3R x 1pc  
Part #6 x 1pc  
Hardware #D x 4pcs  
Hardware #E x 4pcs  
Hardware #F x 4pcs  
Hardware #G x 8pcs  
Hardware #H x 4pcs

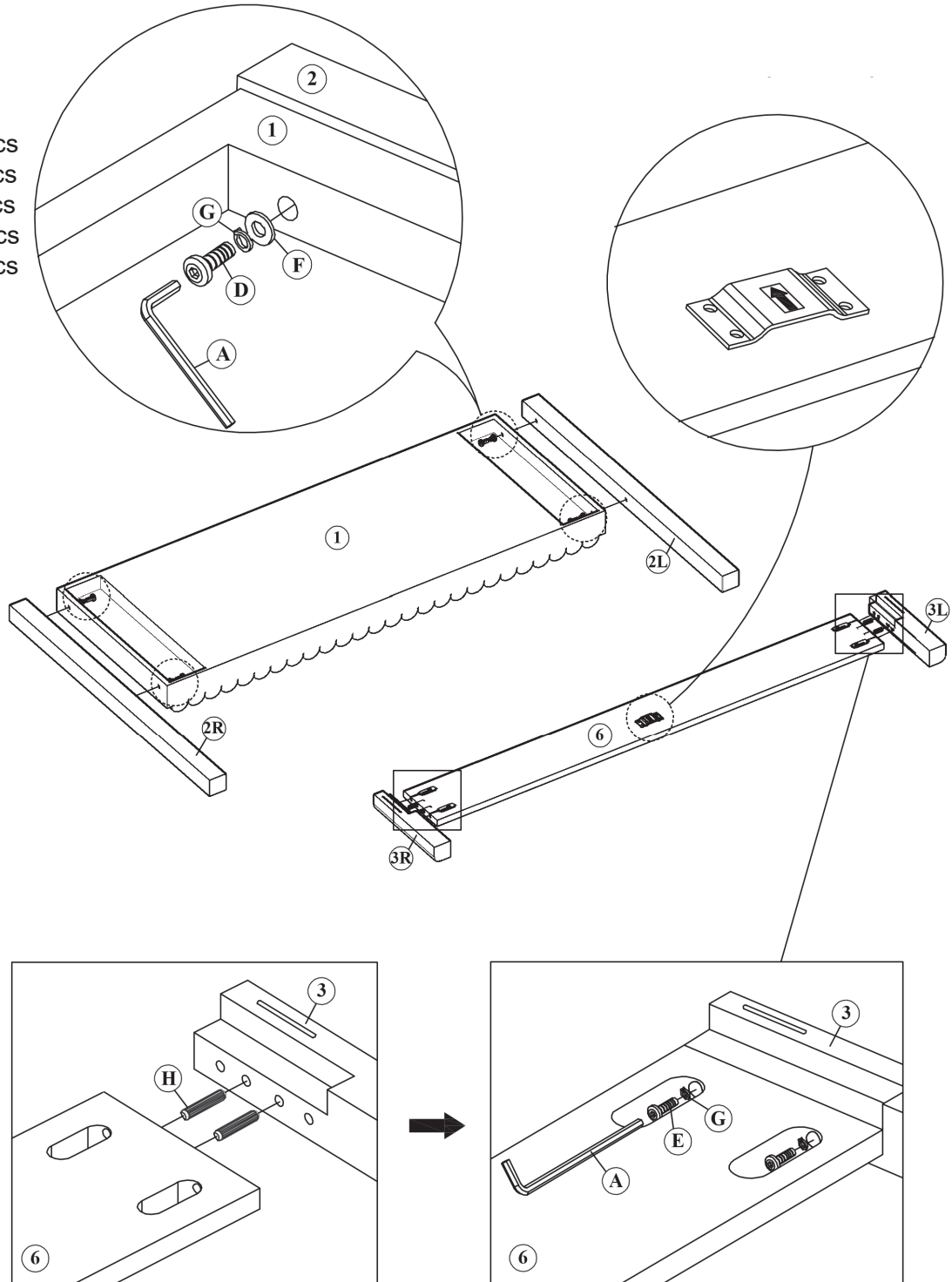

# ASSEMBLY INSTRUCTIONS

## 2

Attach the Side Rails (#4, 5) to Side Rail Leg (#9) using Bolt (#1).

Part #4L x 1pc  
Part #4R x 1pc  
Part #5L x 1pc  
Part #5R x 1pc  
Part #9 x 2pcs  
Hardware #1 x 8pcs

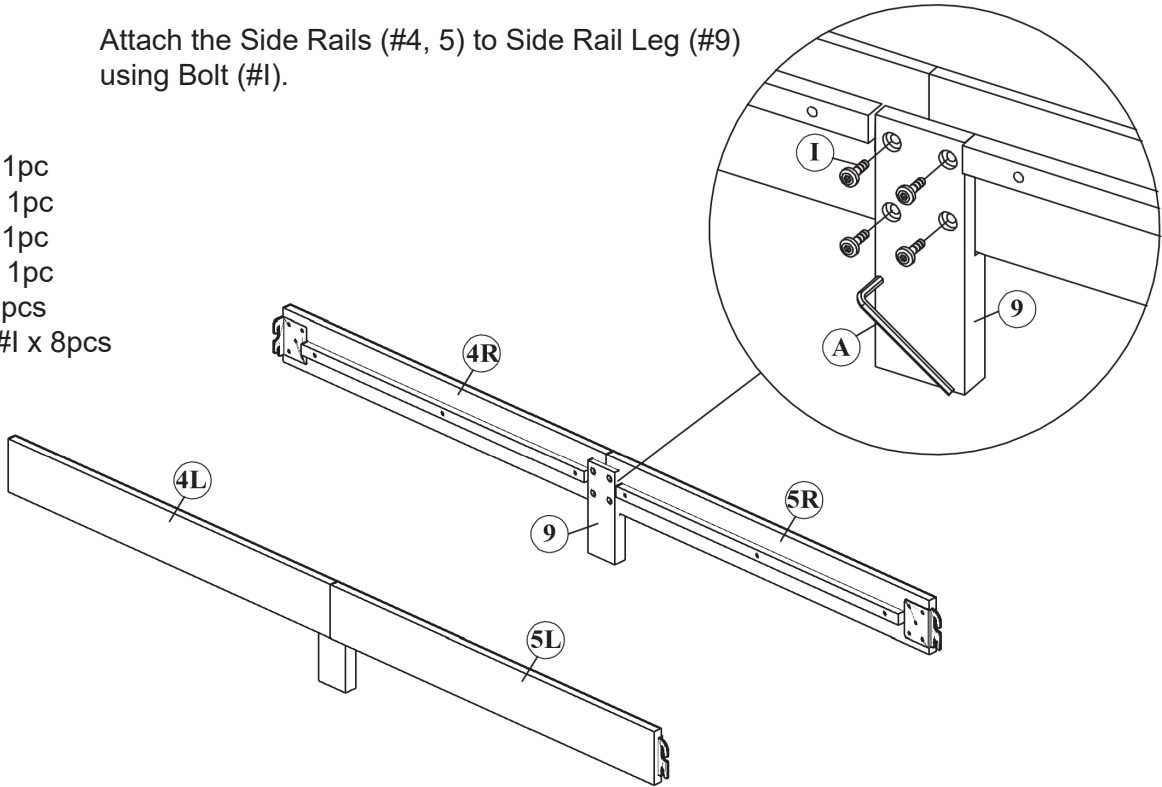

## 3

Align Side Rail (#4R) with Headboard Leg (#2R) and hook pre-attached bracket onto the protruding bolts. Align Side Rail (#5R) with Footboard Leg (#3R) and hook pre-attached bracket onto the protruding bolts. Tighten bolts with provided Allen Wrench (#B).

Repeat for other side with (#L) parts.

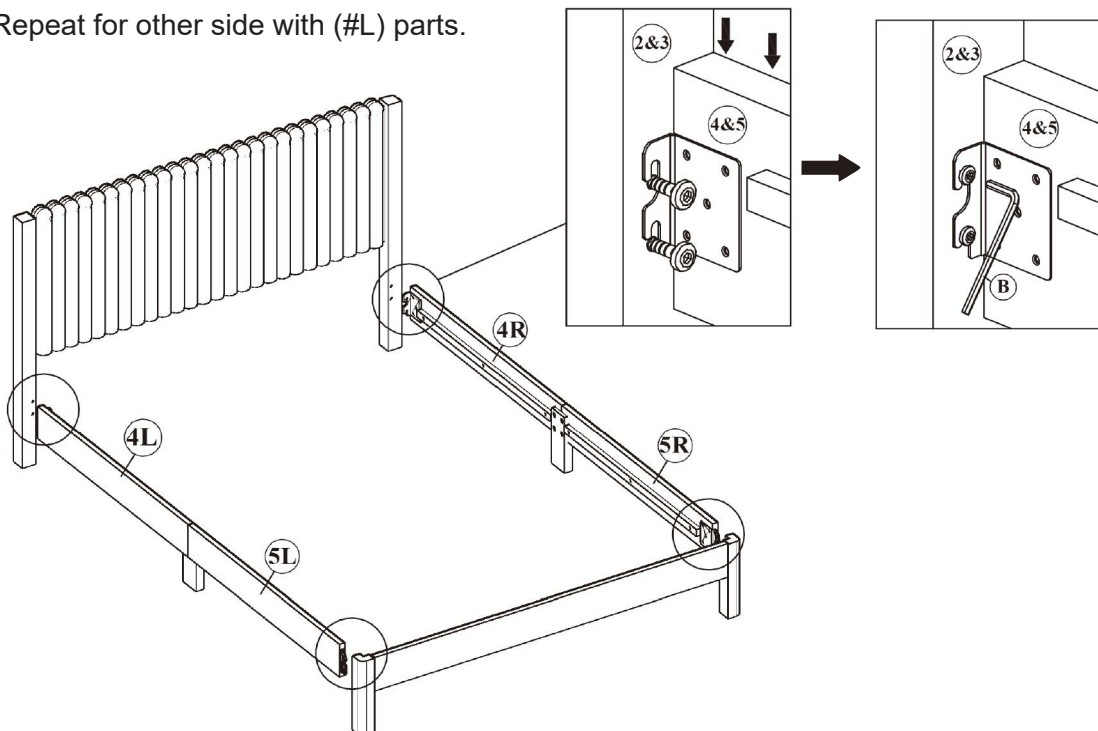

# ASSEMBLY INSTRUCTIONS

## 4

Align one Center Rail (#7) atop two Center Legs (#8). Place 1 set of Slats (#10) on top and secure the first and last slats with Bolt (#C). Repeat for other set.

Part #7 x 2pcs  
Part #8 x 4pcs  
Part #10 x 2sets  
Hardware #C x 8pcs

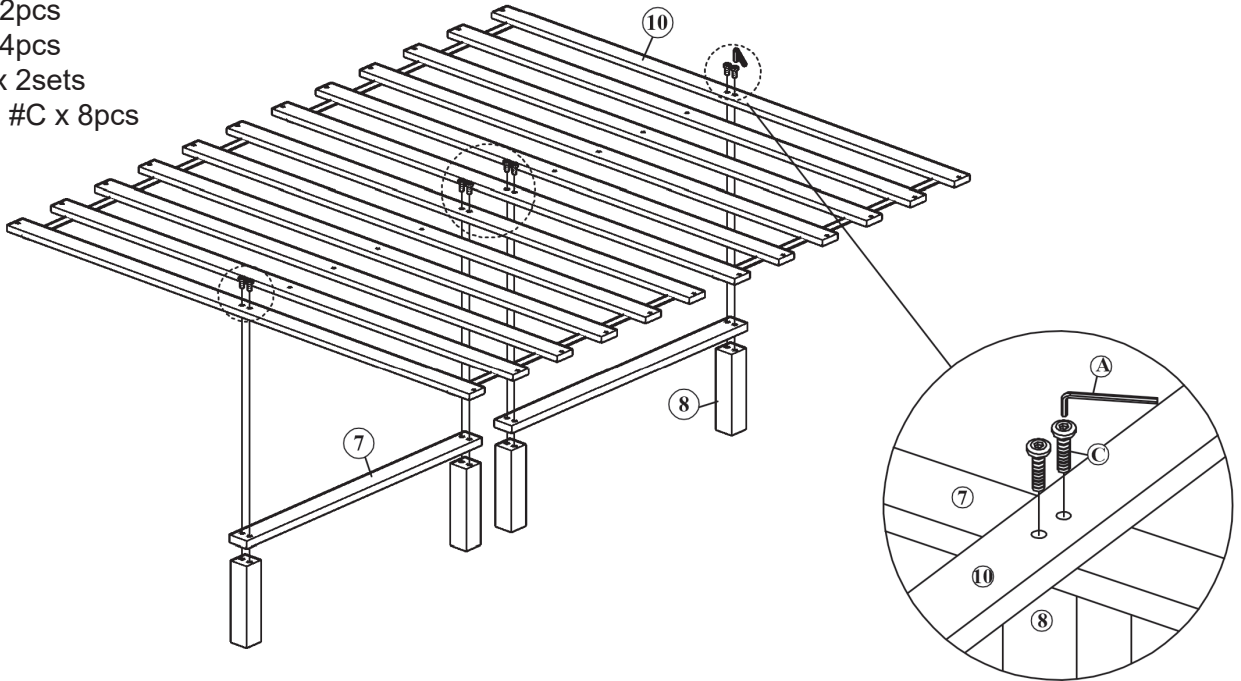

## 5

Place assembled Slats over the Side Rails. Secure every outer end of an individual slat to the Side Rails with Wood Screws (#J). Secure the center of each inner slat to the Center Rail (#7) with Wood Screws (#J).

Hardware #J x 32pcs

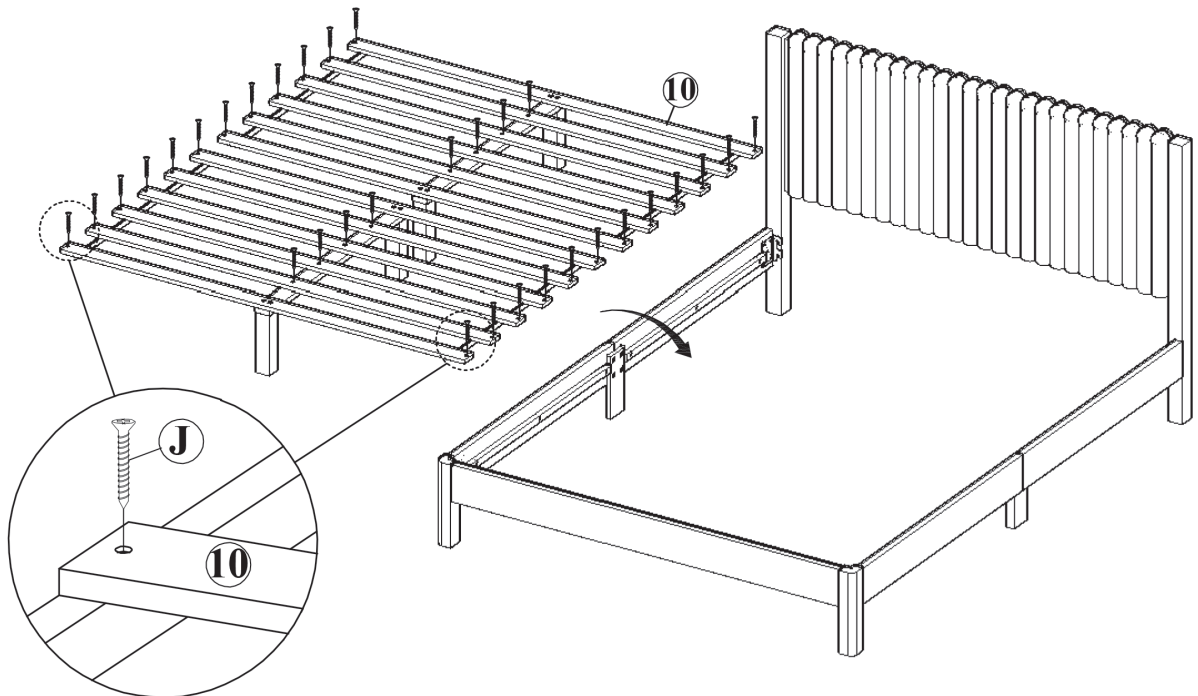

# ASSEMBLY INSTRUCTIONS

---

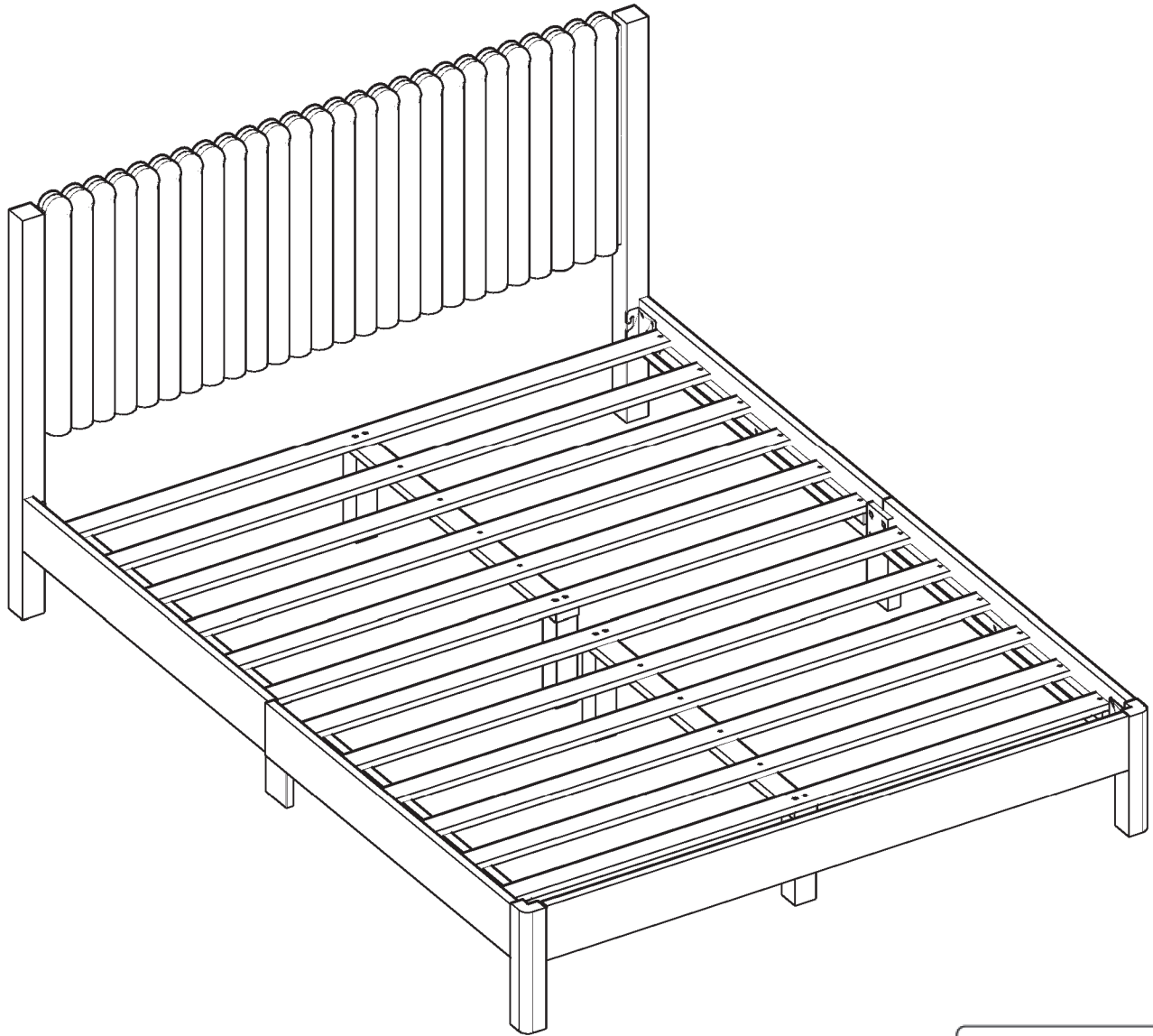

## ASSEMBLY COMPLETED



Please ensure the furniture rests on an even and flat surface. If the product wobbles or feels loose, double-check all bolts and/or screws are properly tightened and secured.

### ✓ **Keep this handy!**

Please retain this instruction manual and any order-related information for future reference.

### ✓ **Lift, don't drag!**

To avoid damage to product please always LIFT the product when transporting or adjusting the placement.