

# ASSEMBLY INSTRUCTIONS

## CORNER SEAT

NO.	PARTS LIST	QTY	DESCRIPTION	NO.	PARTS LIST	QTY	DESCRIPTION
A		1	Seat Frame	G		4	Wooden Leg
B		1	Left Back Rest	H		8	Allen Bolt ØM8*50
C		1	Right Back Rest	I		8	Lock Washer M8
D		1	Seat Cushion	K		8	Flat Washer M8*Ø22*1.5mm
E		1	Left Back Cushion	L		1	Allen Key M5*100*50mm
F		1	Right Back Cushion				

**STEP 1:** Take out Left Back Rest(B), Right Back Rest(C), Seat Cushion(D), Left Back Cushion(E), Right Back Cushion(F), Wooden Leg(G), Allen Bolt(H), Lock Washer(I), Flat Washer(K), Allen Key(L).

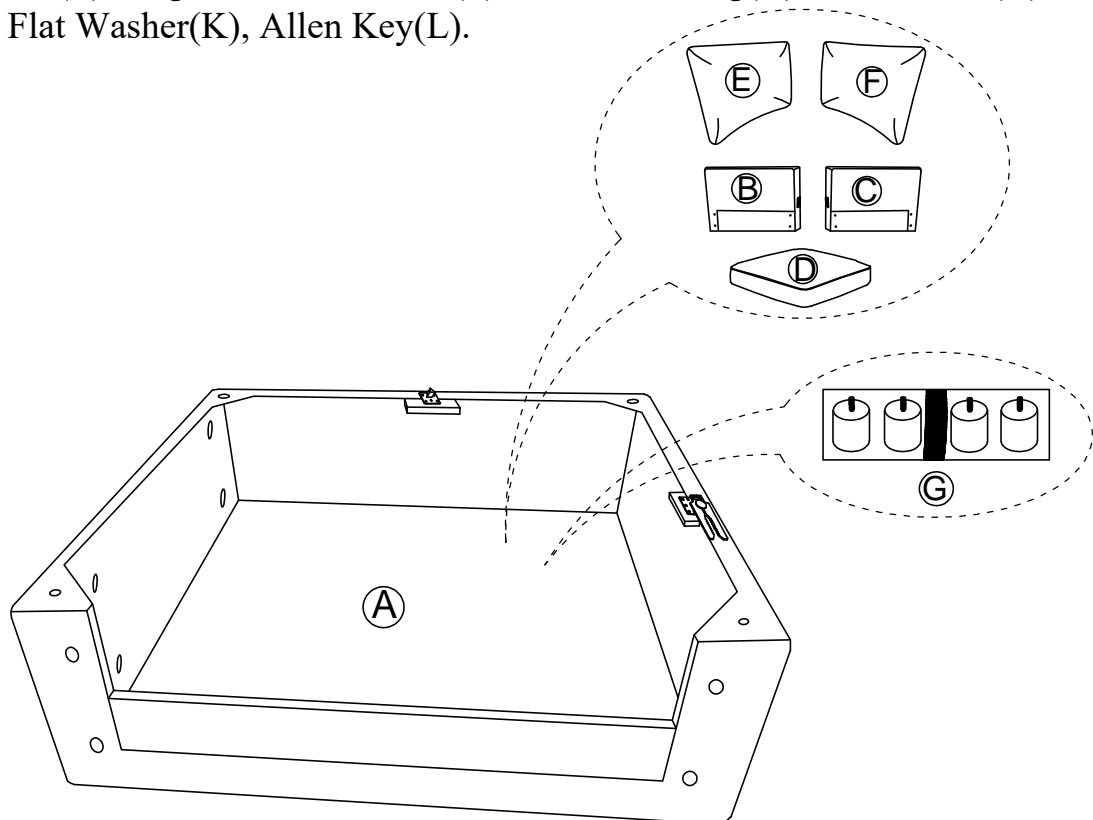

# ASSEMBLY INSTRUCTIONS

## CORNER SEAT

**STEP 2:** Align Wooden Leg (G) onto the bottom of the Seat Frame(A), rotate to tighten it.

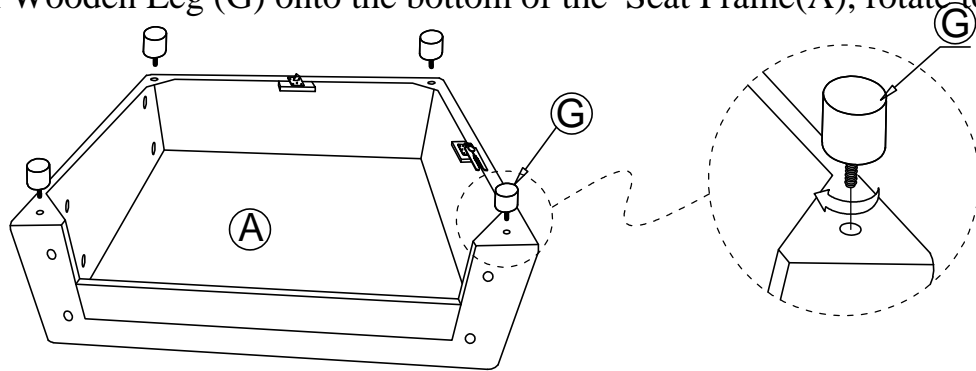

**STEP 3:** Insert Left Back Rest(B) into Right Back Rest(C).

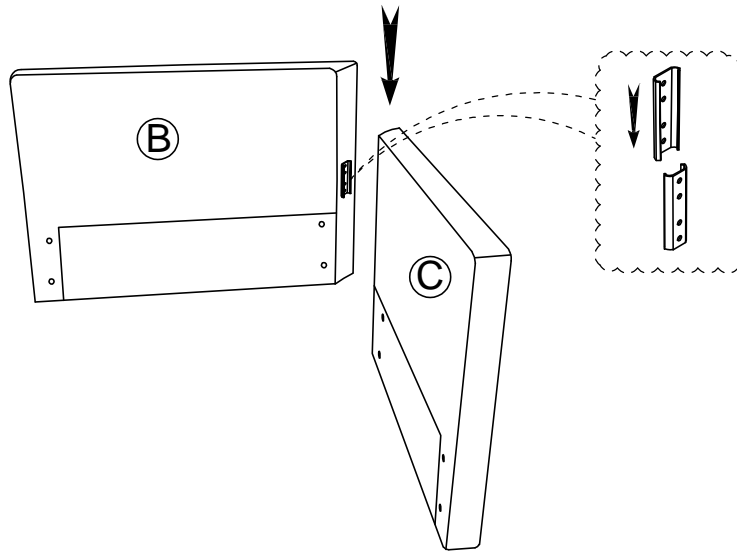

**STEP 4:** Place seat cushion on the seat frame. Match holes of Left Back Rest(B), Right Back Rest(C) and Seat Frame(A) correctly. Serew Allen Bolt(H) Lock Washer(I). Flat Washer(K) with Allen Key(L).

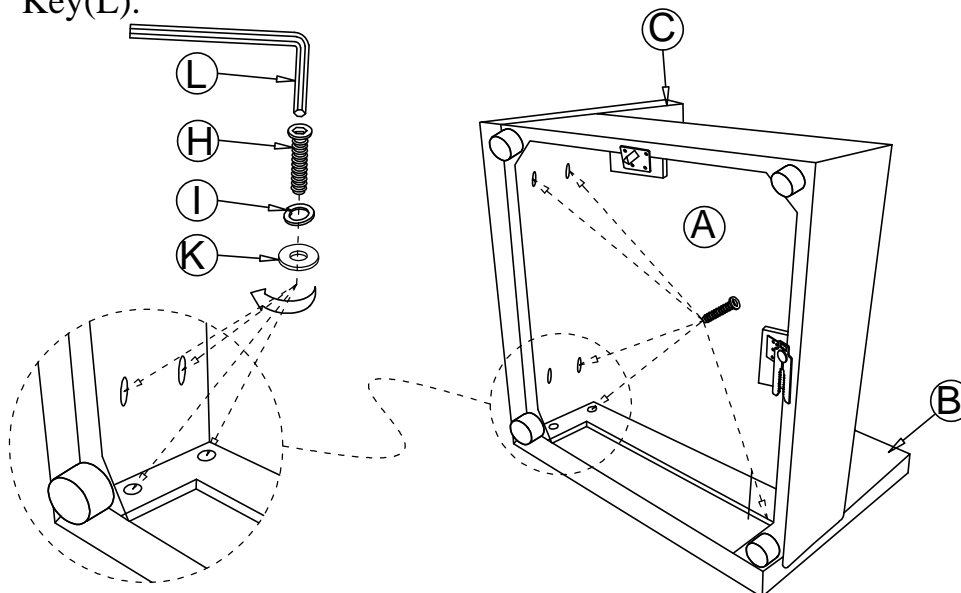

# ASSEMBLY INSTRUCTIONS

## CORNER SEAT

STEP 5: Put Seat Cushion(D) on the Seat Frame(A).

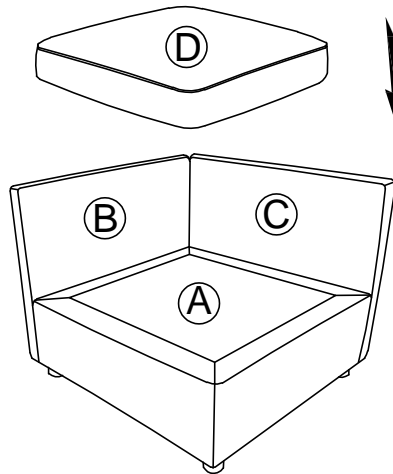

STEP 6: Put Left Back Cushion(E) and Right Back Cushion(F) on Seat Cushion(D).

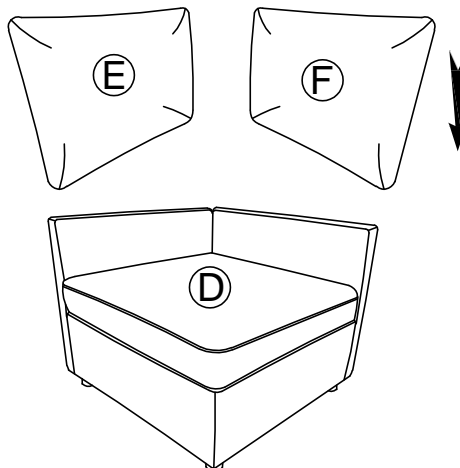

STEP 7: Completed

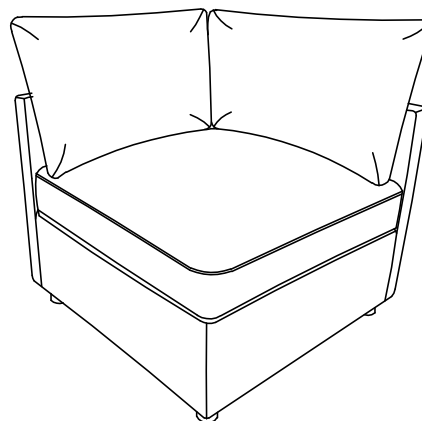

### CARE INSTRUCTIONS FOR FABRIC FURNITURE



To maintain the original appearance of your fabric furniture, please follow the simple care procedures below:

° Avoid exposing furniture directly to sunlight or heating and air conditioning outlets. Exposure to sunlight or heating and air conditioning outlets will fade/damage fabric.

° Wipe gently with a damp soft cloth to remove dust, dirt and any grime build up.

# ASSEMBLY INSTRUCTIONS

## CORNER SEAT

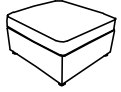
NO.	PARTS LIST	QTY	DESCRIPTION
A		2	CR-Corner Seat
B		2	AC-Armless Chair
C		1	4-Ottoman

**STEP 8:** Sectional connection by placing (B) into piece (A) Continue sectional connection with piece (C) and (B) the same method.

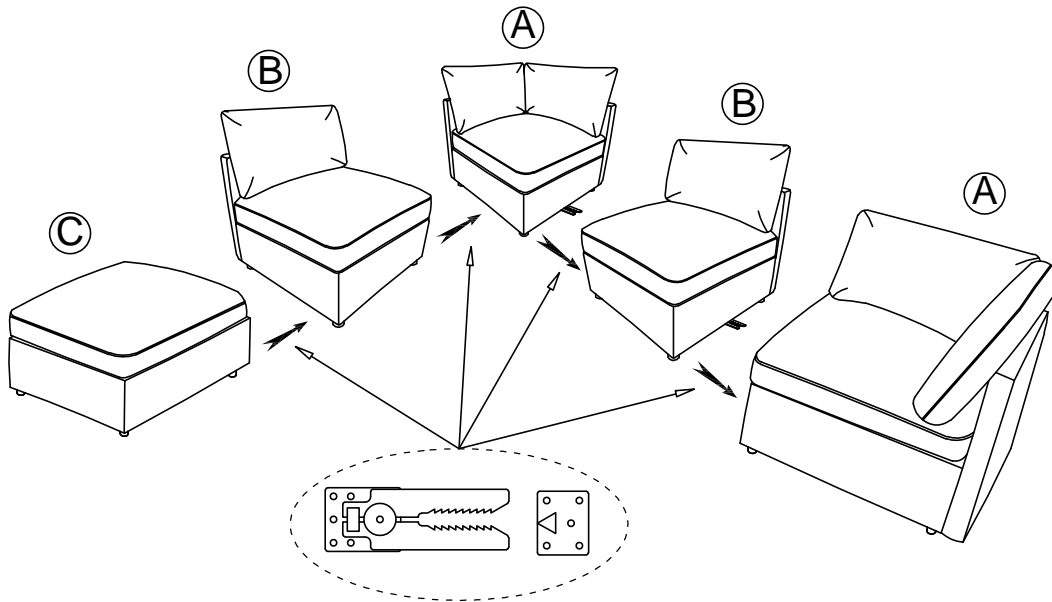



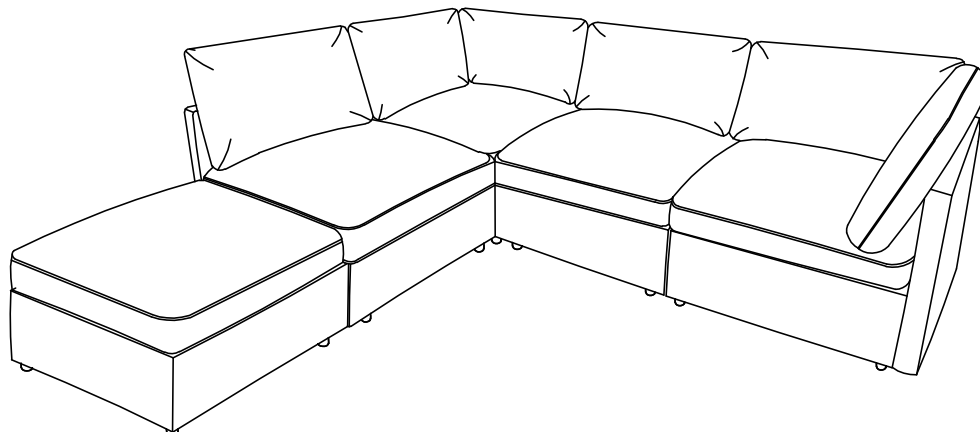



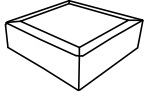

**STEP 9:** Completed

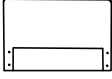

# ASSEMBLY INSTRUCTIONS

## ARMLESS CHAIR

NO.	PARTS LIST	QTY	DESCRIPTION	NO.	PARTS LIST	QTY	DESCRIPTION
A		1	Seat Frame	F		4	Allen Bolt øM8*50
B		1	Back Rest	G		4	Lock Washer M8
C		1	Seat Cushion	H		4	Flat Washer M8*ø22*1.5mm
D		1	Back Cushion	I		1	Allen Key M5*100*50mm
E		4	Wooden Leg	K			

**STEP 1:** Take out Back Rest(B), Seat Cushion(C), Back Cushion(D), Wooden Leg(E), Allen Bolt(F), Lock Washer(G), Flat Washer(H), Allen Key(I).

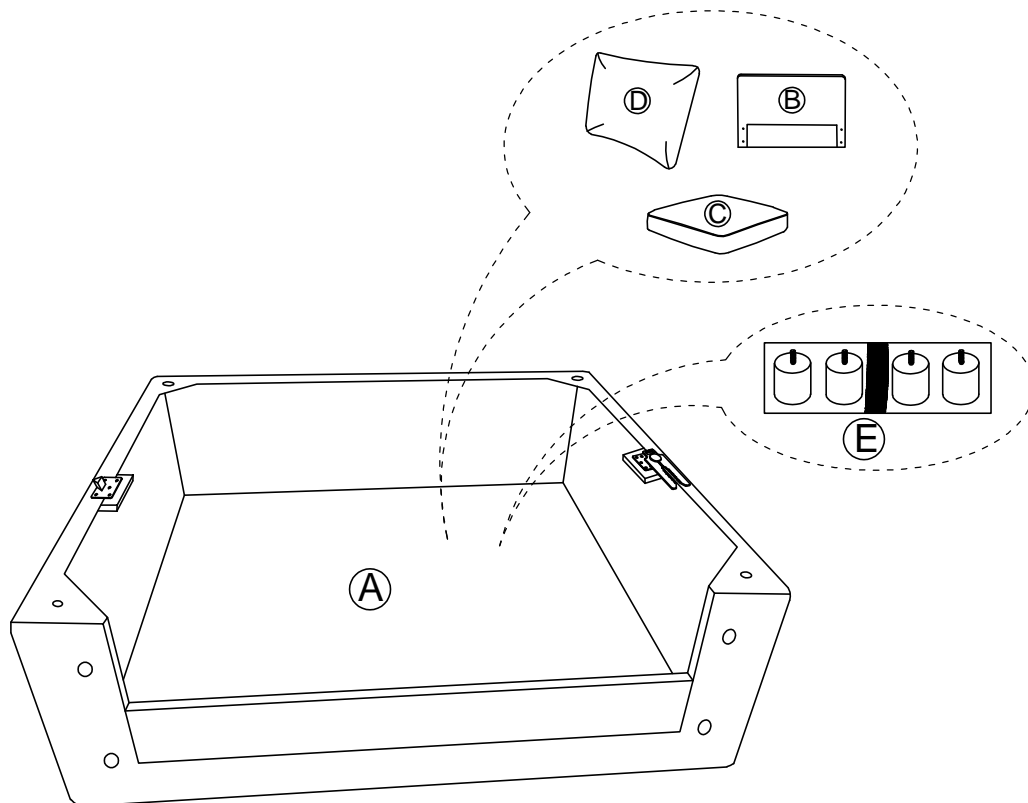

# ASSEMBLY INSTRUCTIONS

## ARMLESS CHAIR

**STEP 2:** Align Wooden Leg (E) onto the bottom of the Seat Frame(A), rotate to tighten it.

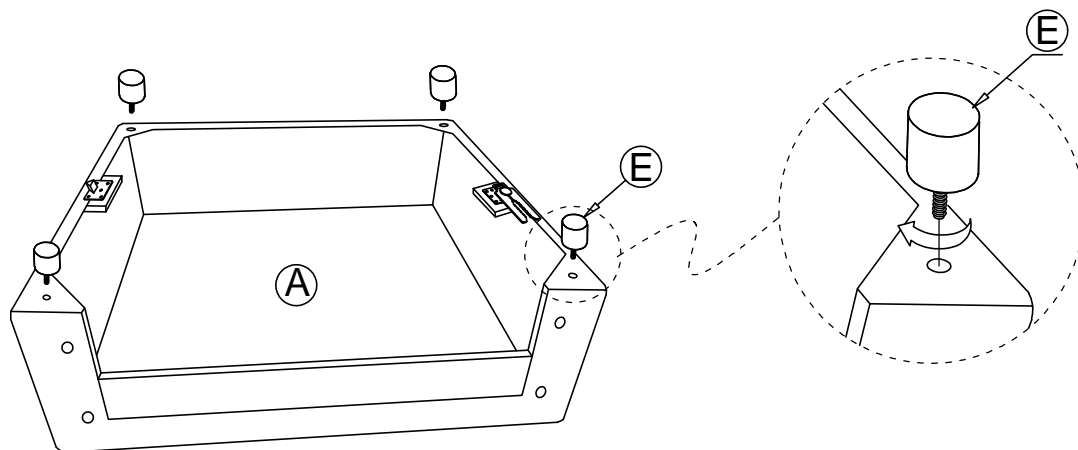

Place seat cushion on the seat frame.

**STEP 3:** Match holes of Back Rest(B) and Seat Frame(A) correctly. Serew Allen Bolt(F) Lock Washer(G), and Flat Washer(H) with Allen Key(I).

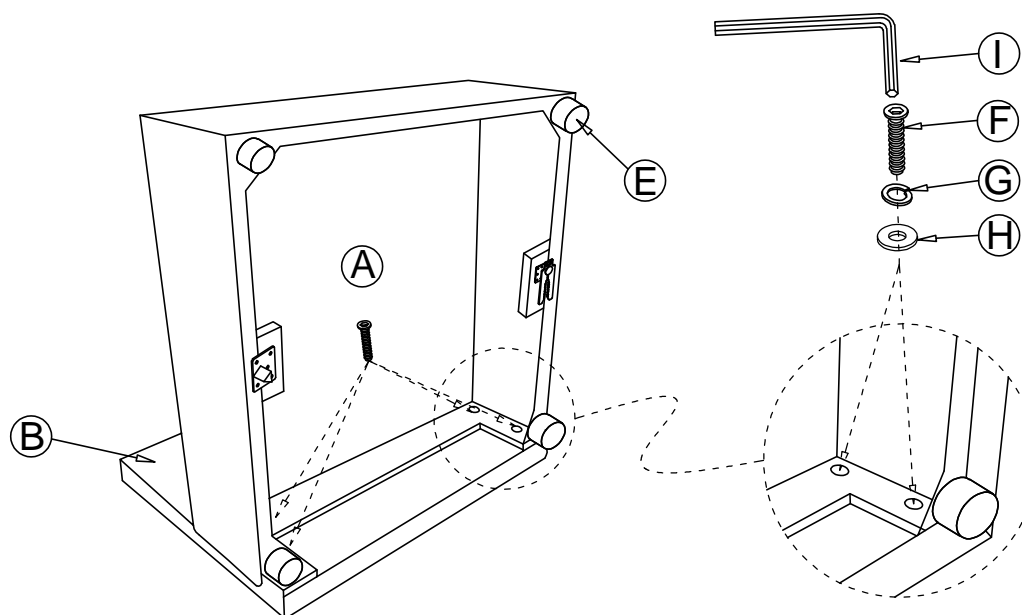

# ASSEMBLY INSTRUCTIONS

## ARMLESS CHAIR

STEP 4: Put Seat Cushion(C) on the Seat Frame(A).

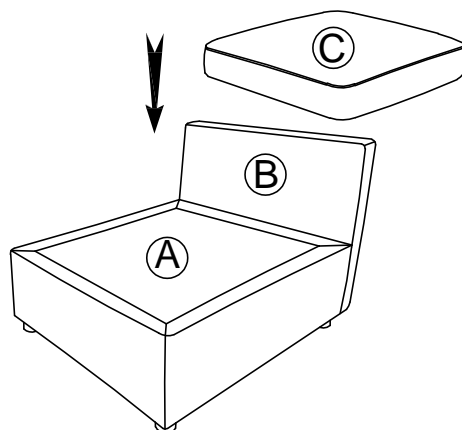

STEP 5: Put Back Cushion(D) on Seat Cushion(C).

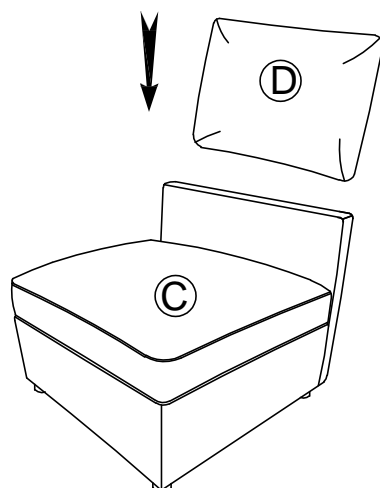

STEP 6: Completed

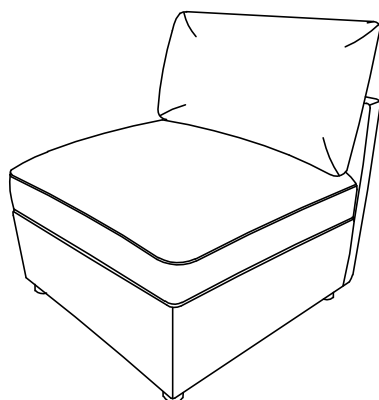

### CARE INSTRUCTIONS FOR FABRIC FURNITURE



**To maintain the original appearance of your fabric furniture, please follow the simple care procedures below:**

°Avoid exposing furniture directly to sunlight or heating and air conditioning outlets. Exposure to sunlight or heating and air conditioning outlets will fade/damage fabric.

°Wipe gently with a damp soft cloth to remove dust, dirt and any grime build up.

# ASSEMBLY INSTRUCTIONS

## ARMLESS CHAIR

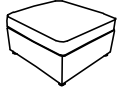
NO.	PARTS LIST	QTY	DESCRIPTION
A		2	CR-Corner Seat
B		2	AC-Armless Chair
C		1	4-Ottoman

**STEP 8:** Sectional connection by placing (B) into piece (A) Continue sectional connection with piece (C) and (B) the same method.

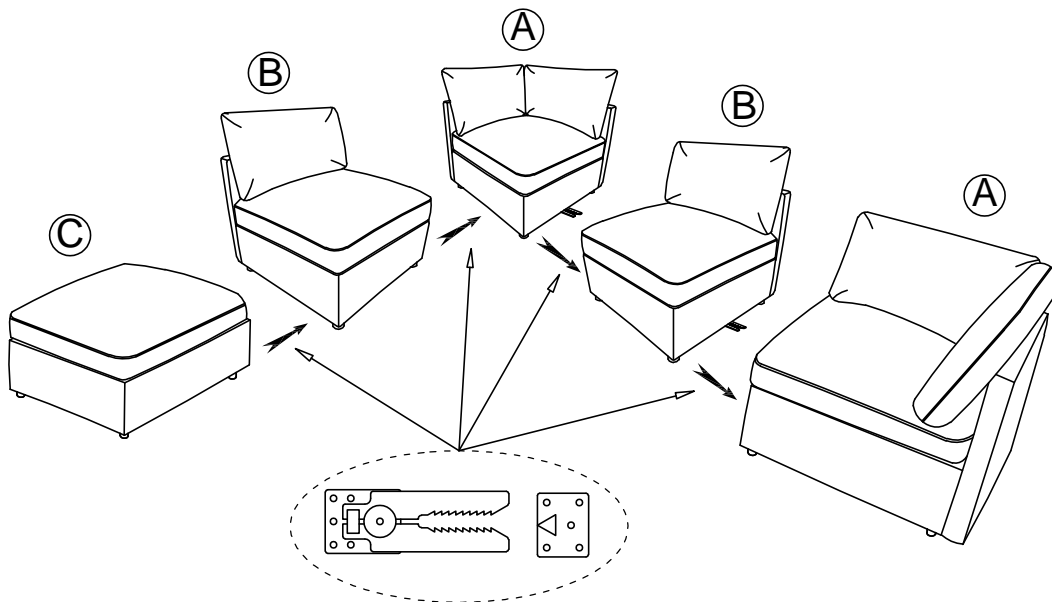

**STEP 9:** Completed

