

ASSEMBLY INSTRUCTION

AVA COLLECTION

D1891-10



MODEL : AVA DINING TABLE

Thank you for purchasing this quality product. Be sure to check all packing materials carefully for small parts, which may have come loose inside the carton during shipment. Identify and count all items and compare with the parts list and/or hardware list shown below.

Please read all instructions carefully. See the hardware and furniture part listing for guidance. Be sure you have all parts listed before beginning assembly. Place all wooden parts on a clean, flat surface to protect the finish from scratches. Follow the diagram to assemble.

CAUTION

1. Do not fully tighten the nuts or bolts until the table is fully assembled.
2. Please tighten by hand, not by a drill. Overtightening will damage threads. Do not overtighten.
3. Keep all hardware out of the reach of children.

| PARTS LIST | | | |
|------------|-------------|-----------------------------------------------------------------------------------|-------|
| ITEM | DESCRIPTION | SKETCH | QTY |
| A | TOP PANEL |  | 1 PC |
| B | LEG |  | 4 PCS |

| HARDWARE LIST | | | |
|---------------|--------------------------|-------------------------------------------------------------------------------------|--------|
| ITEM | DESCRIPTION | SKETCH | QTY |
| 1 | JCBC SCREW M6 x 1" |  | 20 PCS |
| 2 | SPRING WASHER M6 x 7/16" |  | 20 PCS |
| 3 | FLAT WASHER M6 x 6/8" |  | 20 PCS |
| 4 | M4 ALLEN KEY (3-15/16") |  | 1 PC |

HARDWARE DIMENSIONS VERIFICATION TOOL



STEP 1: Place the table top (A) upside down on a flat and soft surface.

Assemble the table leg (B) to the table top (A) by using the Allen key (4) with hardware 1, 2, and 3.

****Attention: DO NOT TIGHTEN THE SCREWS.**

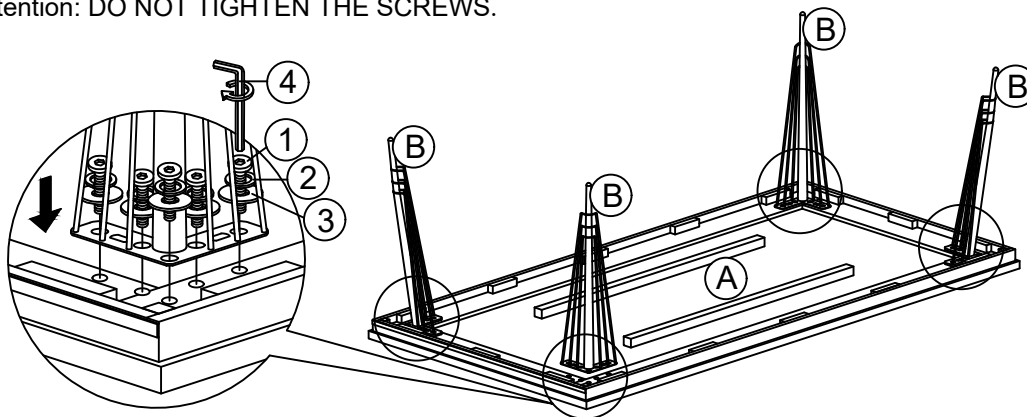

STEP 2: To level the table, stand the table up on a flat surface and tighten all screws with Allen key (4).

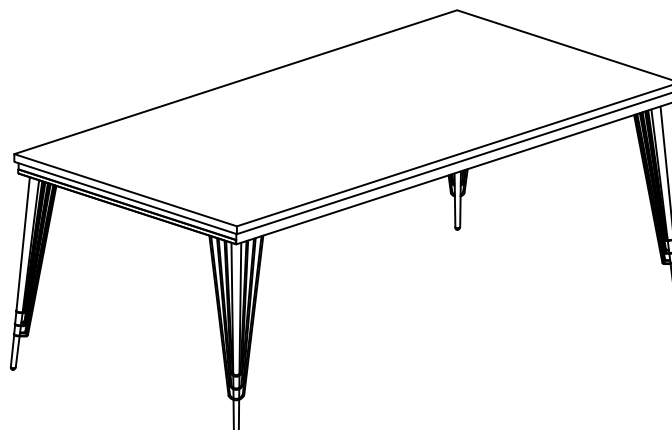

FULLY SET-UP

ASSEMBLY INSTRUCTION

AVA COLLECTION

D1891-20



MODEL : AVA DINING CHAIR (2 PER CARTON)









Thank you for purchasing this quality product. Be sure to check all packing materials carefully for small parts, which may have come loose inside the carton during shipment. Identify and count all items and compare with the parts list and/or hardware list shown below.

Please read all instructions carefully. See the hardware and furniture part listing for guidance. Be sure you have all parts listed before beginning assembly. Place all wooden parts on a clean, flat surface to protect the finish from scratches. Follow the diagram to assemble.

CAUTION

1. Do not fully tighten the nuts or bolts until the table is fully assembled.
2. Please tighten by hand, not by a drill. Overtightening will damage threads. Do not overtighten.
3. Keep all hardware out of the reach of children.

| PARTS LIST | | | |
|------------|-------------|-----------------------------------------------------------------------------------|-------|
| ITEM | DESCRIPTION | SKETCH | QTY |
| A | BACKREST |  | 2 PCS |
| B | SEAT |  | 2 PCS |
| C | LEG |  | 8 PCS |

| HARDWARE LIST | | | |
|---------------|--------------------------|---------------------------------------------------------------------------------------|--------|
| ITEM | DESCRIPTION | SKETCH | QTY |
| 1 | JCBC SCREW M6 x 1" |  | 32 PCS |
| 2 | JCBB SCREW M8 x 2" |  | 10 PCS |
| 3 | SPRING WASHER M6 x 7/16" |  | 32 PCS |
| 4 | FLAT WASHER M6 x 6/8" |  | 32 PCS |
| 5 | SPRING WASHER M8 x 1/2" |  | 10 PCS |
| 6 | FLAT WASHER M8 x 7/8" |  | 10 PCS |
| 7 | ALLEN KEY M4 (3-15/16") |  | 1 PC |
| 8 | ALLEN KEY M5 (2-9/16") |  | 1 PC |

WEIGHT CAPACITY (PER CHAIR) 300 LBS

**HARDWARE DIMENSIONS
VERIFICATION TOOL**

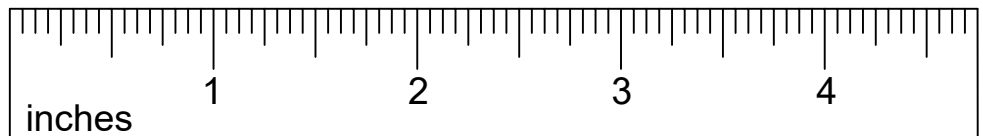

STEP 1: Place the Backrest (A) on a soft and clean surface.

Assemble the Seat (B) with the Backrest (A) by using the Allen Key (8) with hardware 2, 5, and 6.

****Attention: DO NOT TIGHTEN THE BOLTS.**

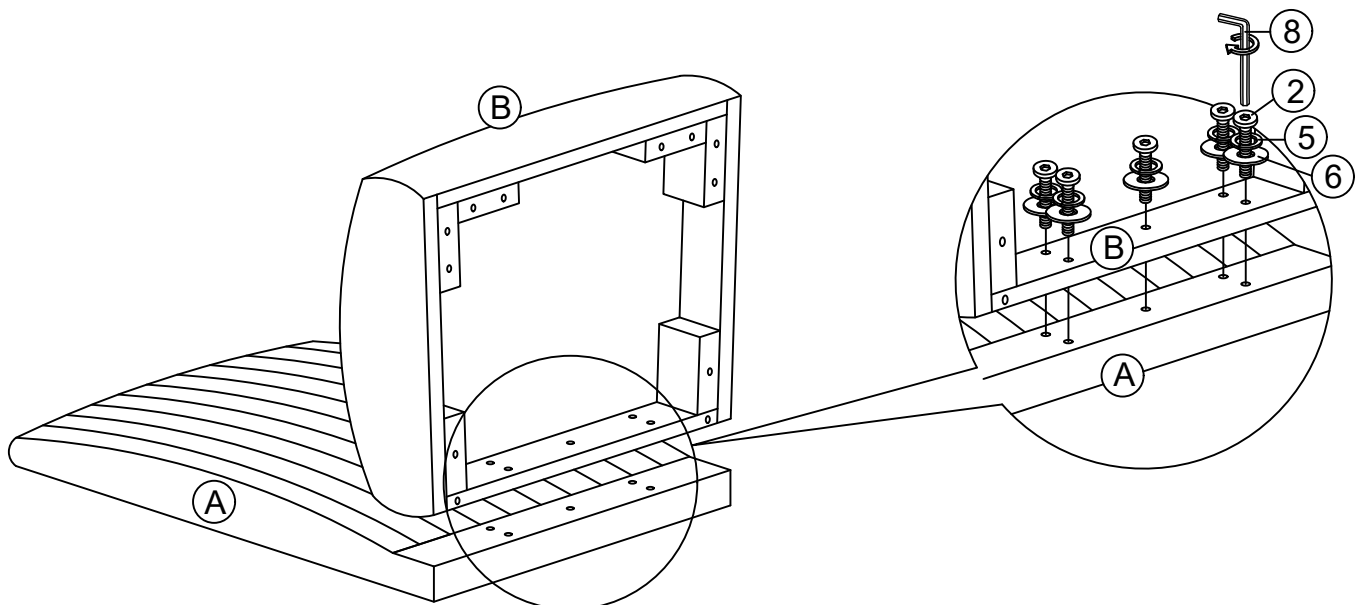

STEP 2: Assemble each leg (C) to seat (B) and backrest (A) by using Allen Key (7) with hardware 1, 3, and 4.

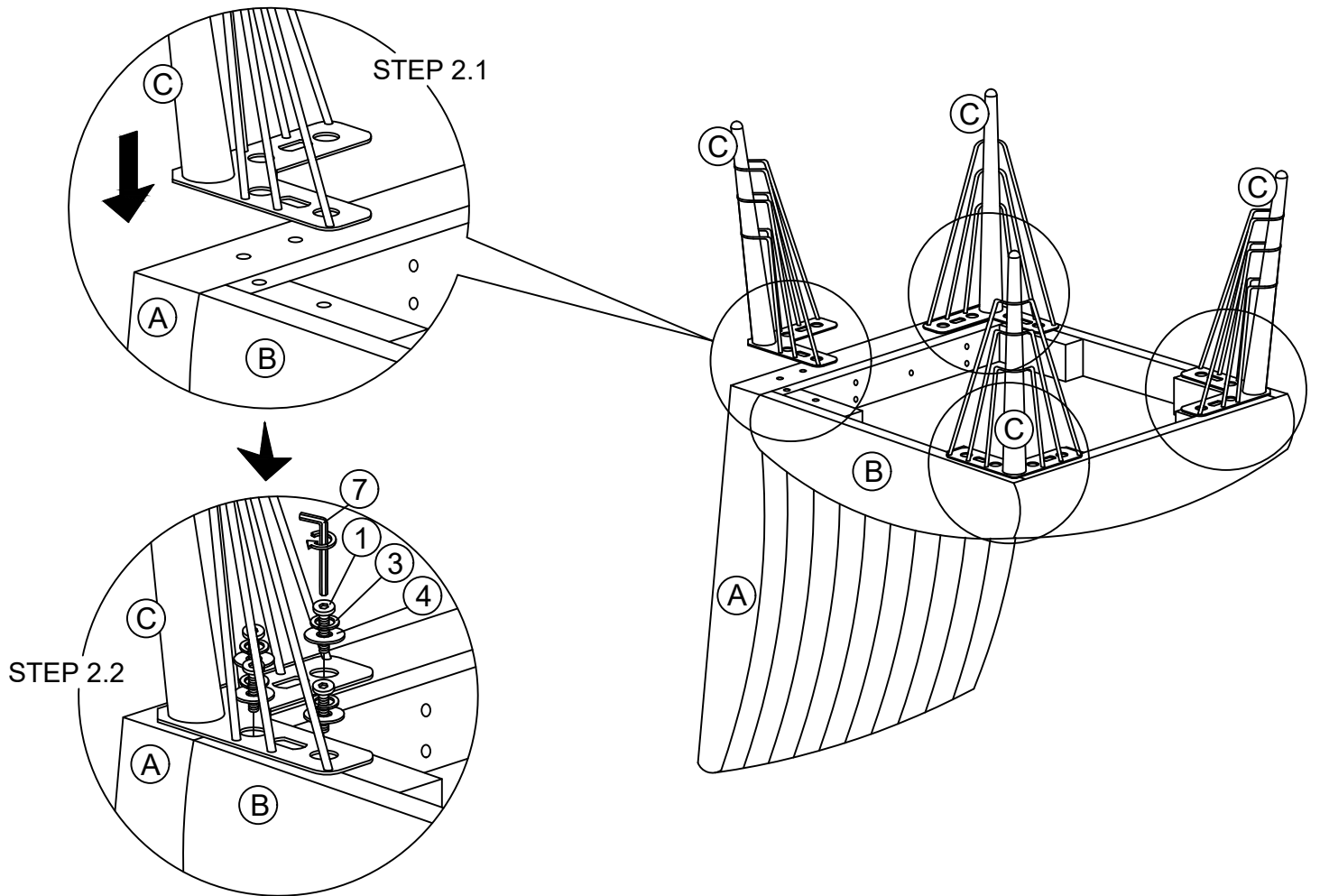

STEP 3: To level the chair, stand the chair up on a flat surface and tighten all the bolts using Allen Key (7) and (8).

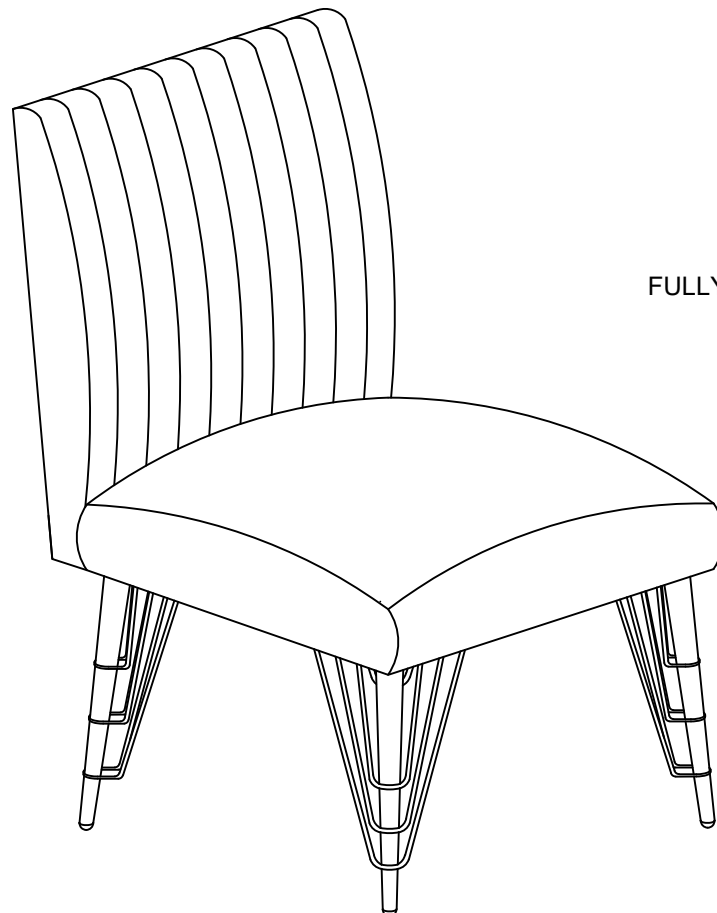

FULLY SET-UP