

Assembly Instructions

Model No. YDS-Y0009

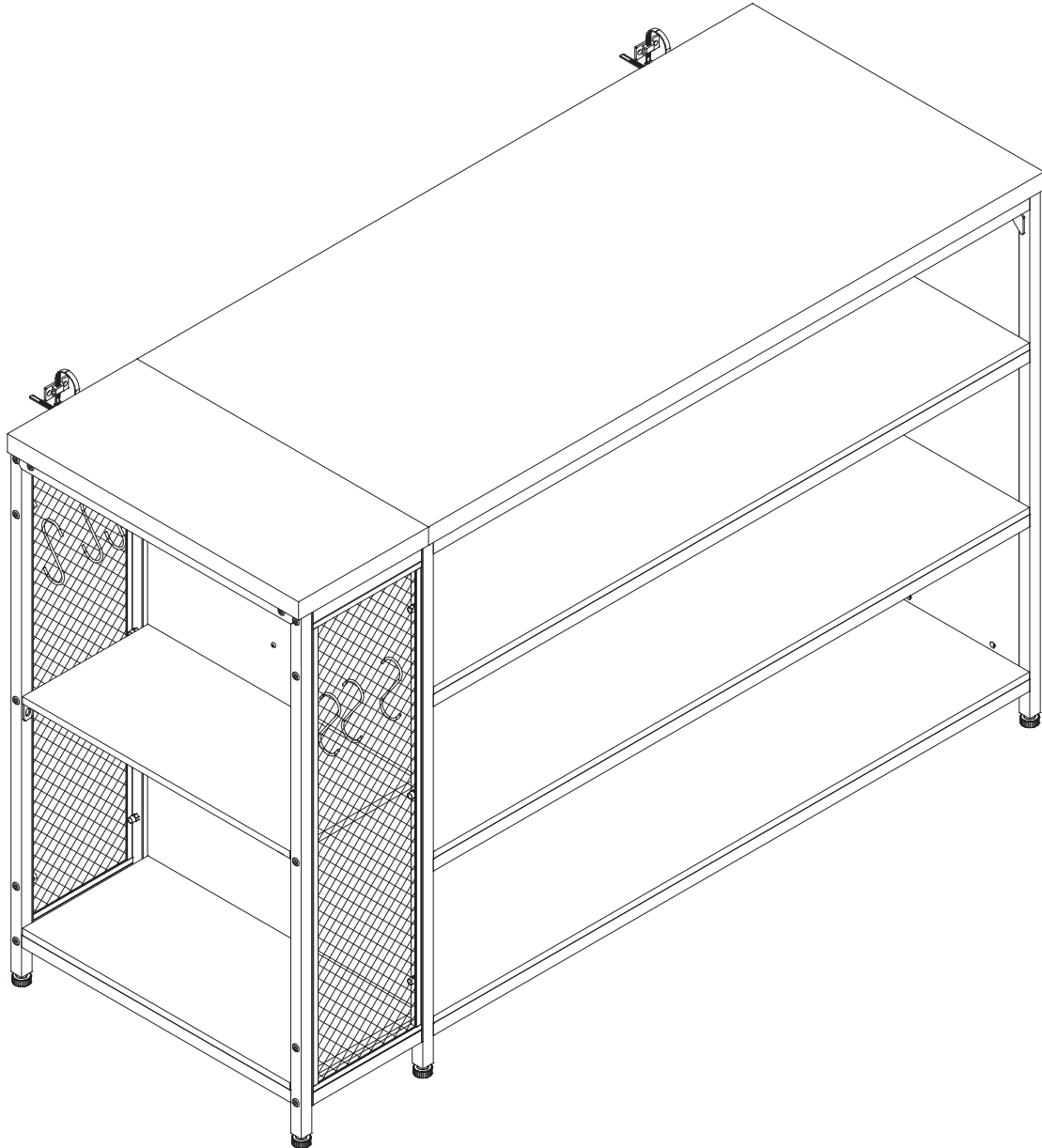

Notes: Don't tighten screws completely at first, just in case parts were assembled wrong and need be disassembled. Tighten screws at last when all parts are put together.

Contact us!

We're here to help!

If you have any issues with this product, please contact our customer service team **before returning** it.



We want you to be completely satisfied with your purchase! If anything is missing, damaged, incorrect, or not what you expected, don't worry. Please keep the outer packaging and take photos of both the packaging and products, and then reach out to us at **YDS13538281408@163.com** We'll take care of everything and send you a free replacement, so you can enjoy your purchase as soon as possible without any hassle.

Assembly Instructions:

1. Carefully read these instructions and keep them for future reference.
2. Refer to the parts list for guidance and ensure that you have all the pieces before starting the assembly process, if anything is missing, damaged, incorrect, contact us **FIRSTLY BEFORE** assembling.
3. When assembling, place all parts on a soft, clean, and flat surface, such as a carpet, to prevent any scratches.
4. To avoid misalignment of the holes, Please don't full tighten the screws until you ensure all parts in place.

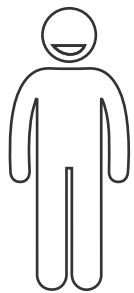

X2

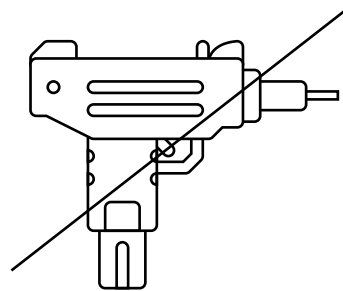
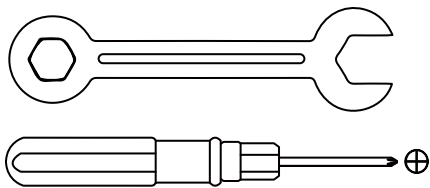

When using the electric screwdriver ,
Reduce the power and torque to avoid damaging the furniture

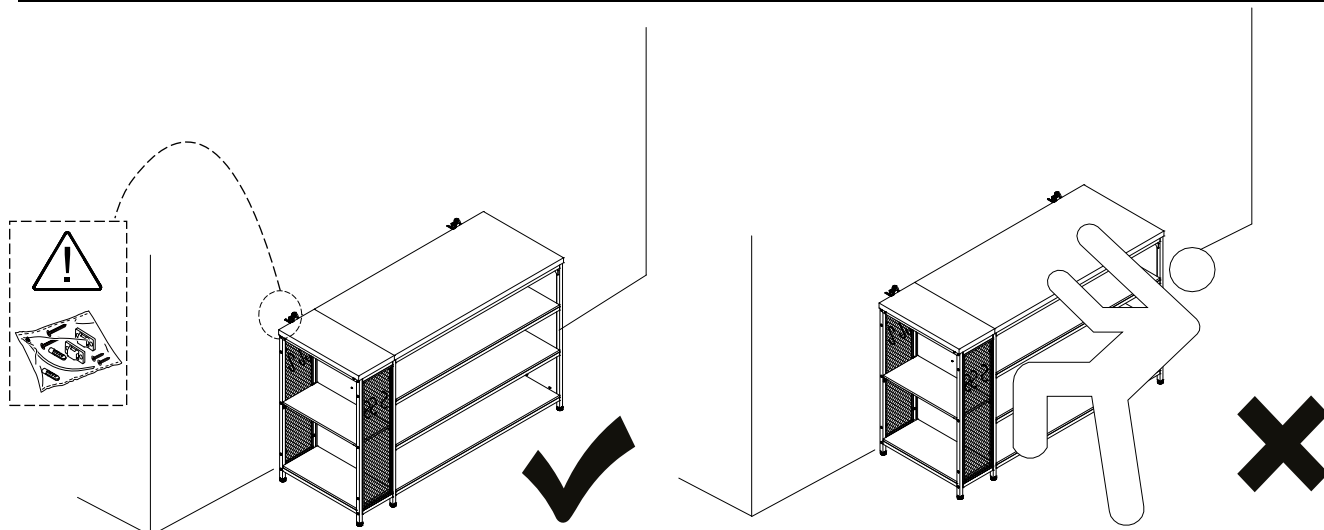
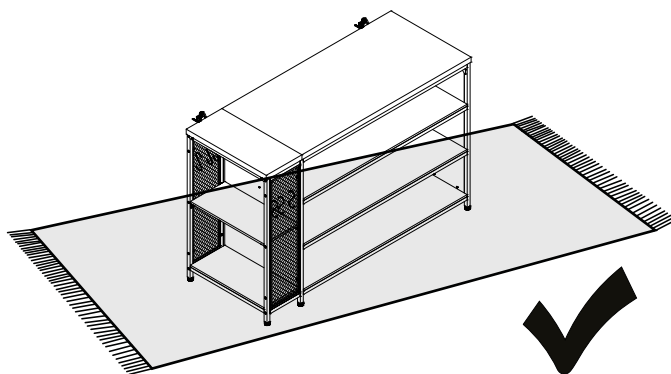
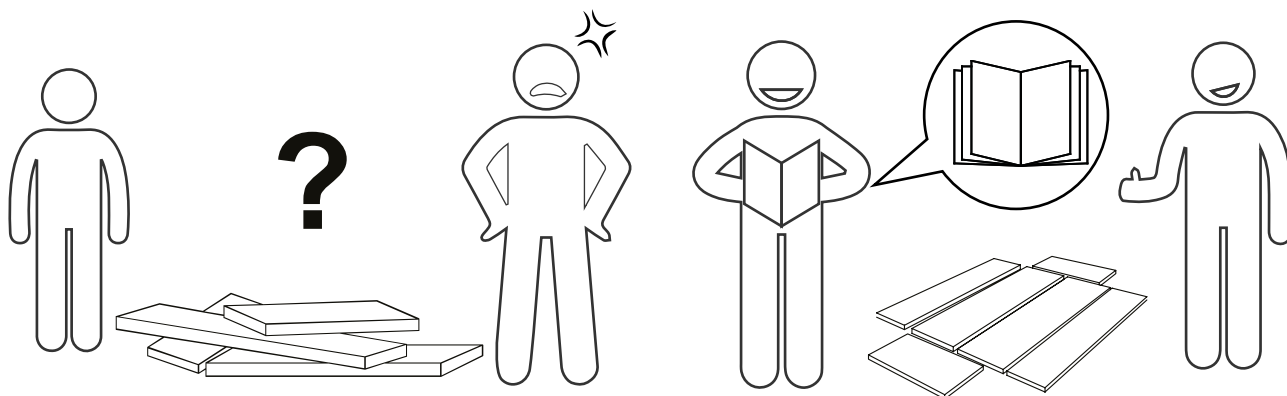

(Install tip-over restraint provided)

Use of tip-over restraints may only reduce but not eliminate the risk of tip-over.

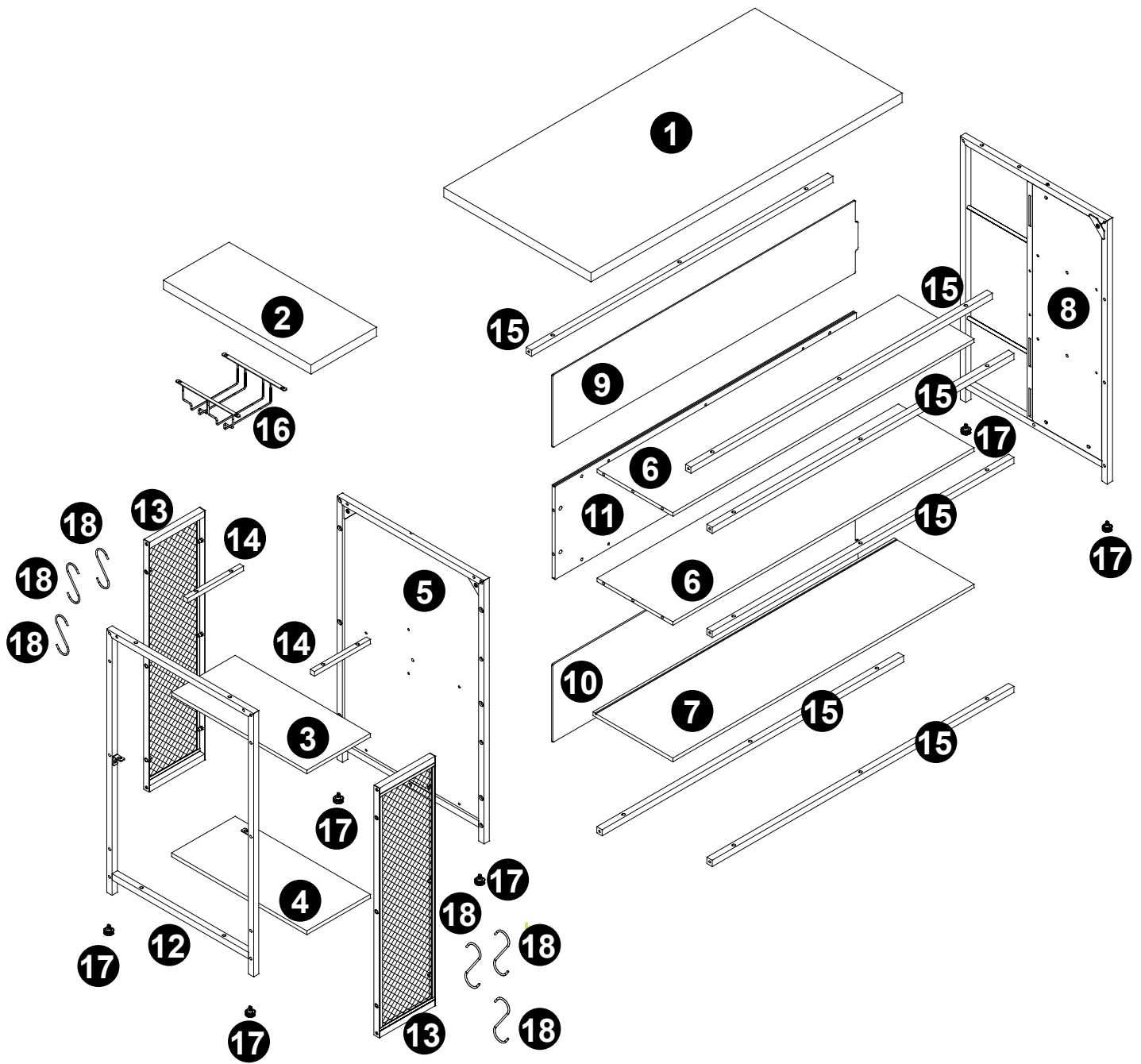

⚠ Caution

Make sure all parts are included. Most board parts are labeled or stamped on the raw edge. Contact us for free replacement if having damaged or missing parts

Parts & Hardware List

1166X552X30

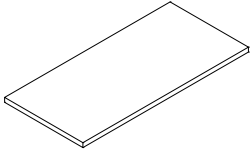

① 1pc

552X246X30

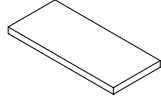

② 1pc

507X238X12

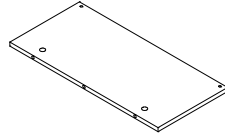

③ 1pc

507X238X12

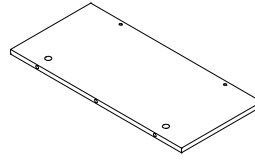

④ 1pc

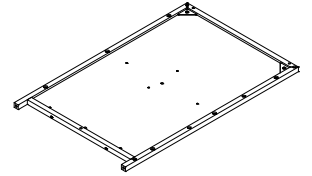

⑤ 1pc

1129X284X12

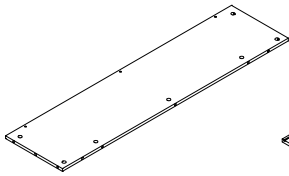

⑥ 2pc

1129X300X12

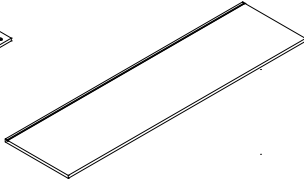

⑦ 1pc

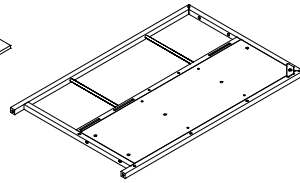

⑧ 1pc

235X1144.5X4

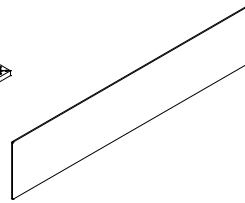

⑨ 1pc

253X1144.5X4

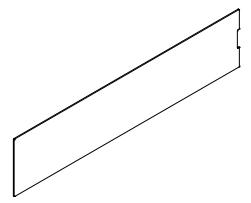

⑩ 1pc

302X1129X12

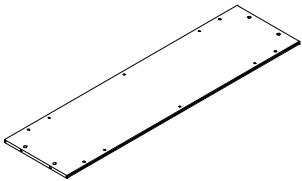

⑪ 1pc

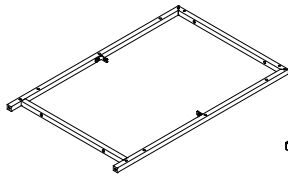

⑫ 1pc

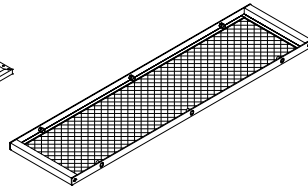

⑬ 2pc

15X15X210

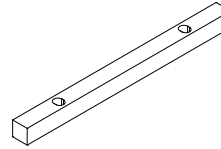

⑭ 2pc

20X20X1130

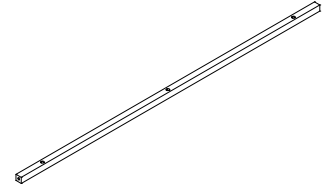

⑮ 6pc

M8

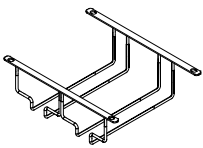

⑯ 1pc

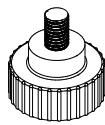

⑰ 6pc



⑱ 6pc

Hardware List



A

4pcs



B

30pcs



C

28pcs



D

2pcs



E

18pcs



F

18pcs



G

10pcs



H

4pcs



I

4pcs



J

4pcs

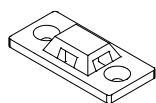

K

4pcs



L

2pcs

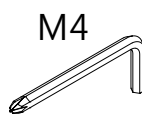

M

1pcs

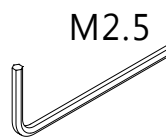

N

1pcs



O

4pcs

Installation of Cams and Pins

Screw the pin into the hole. To set the cams correctly, ensure that the arrow on the cam is opening to the hole of the pin it is locking. Lock the cam by turning the cam head with a screwdriver until it is tightened. Please do not use an electric screwdriver to assemble the unit.

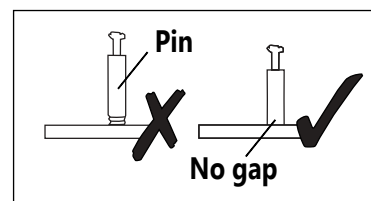
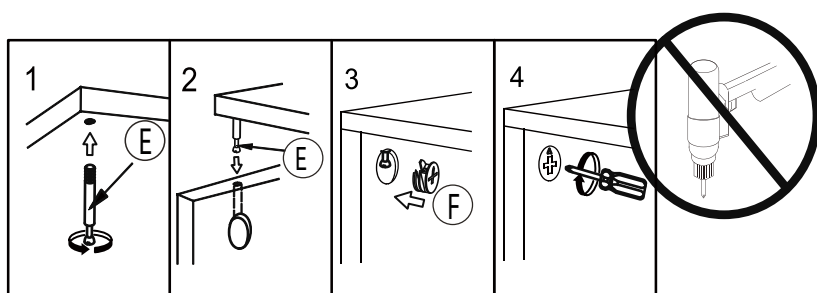

Read each step carefully before starting. It is very important that each step of instruction is performed in the correct order. If these steps are not followed in sequence, assembly difficulties will occur.

1

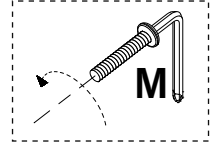
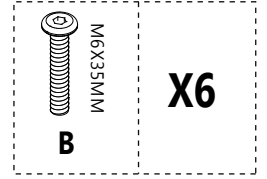
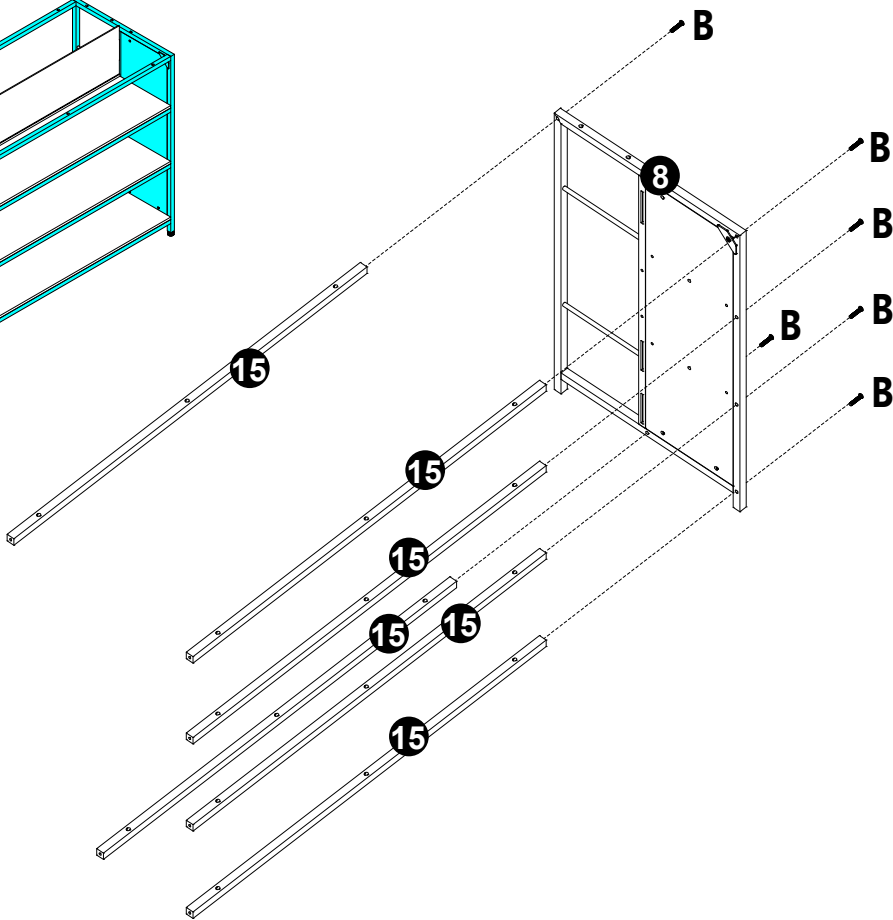
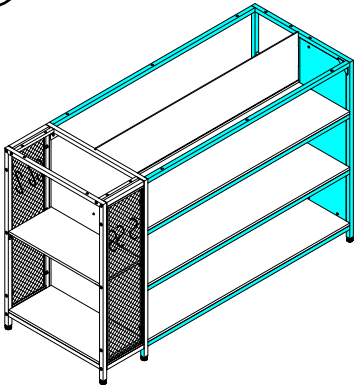

2

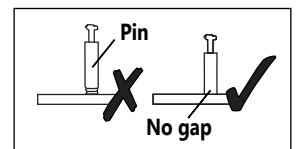
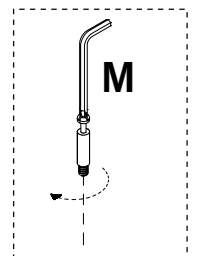
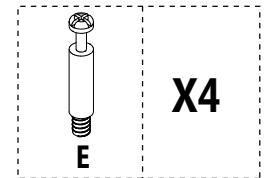
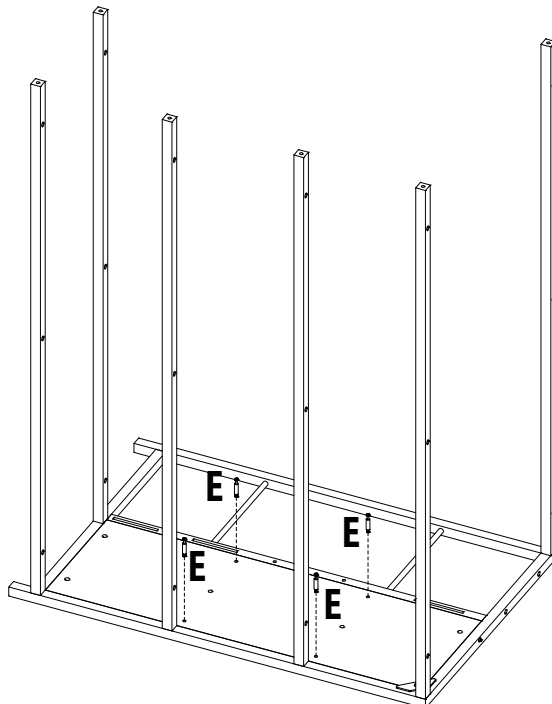
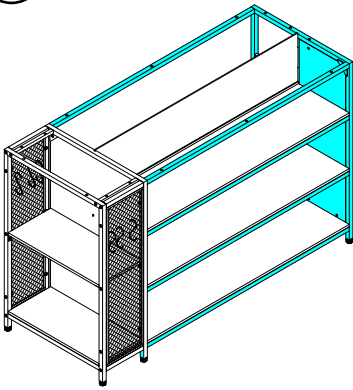

3

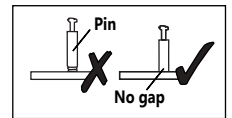
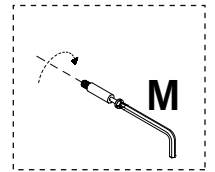
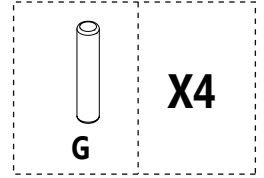
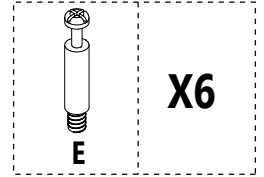
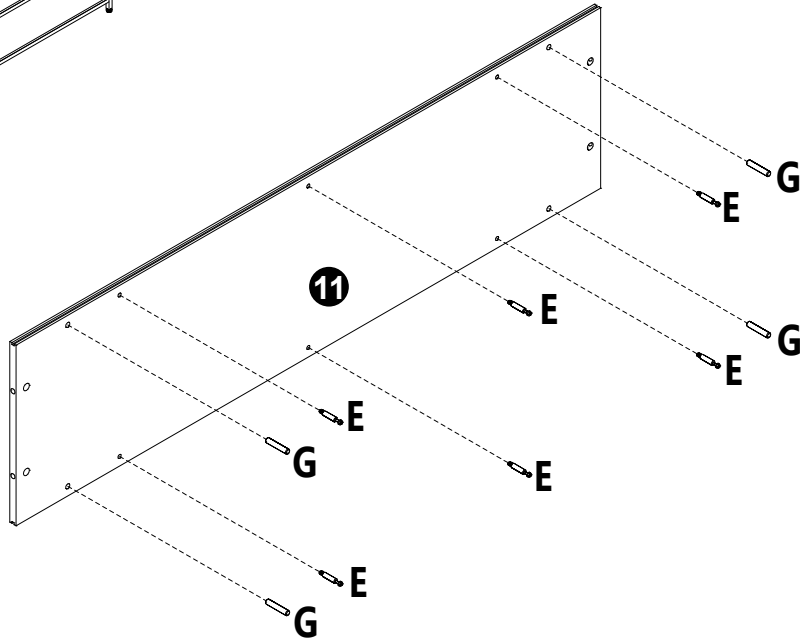
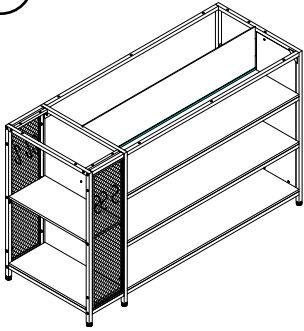

4

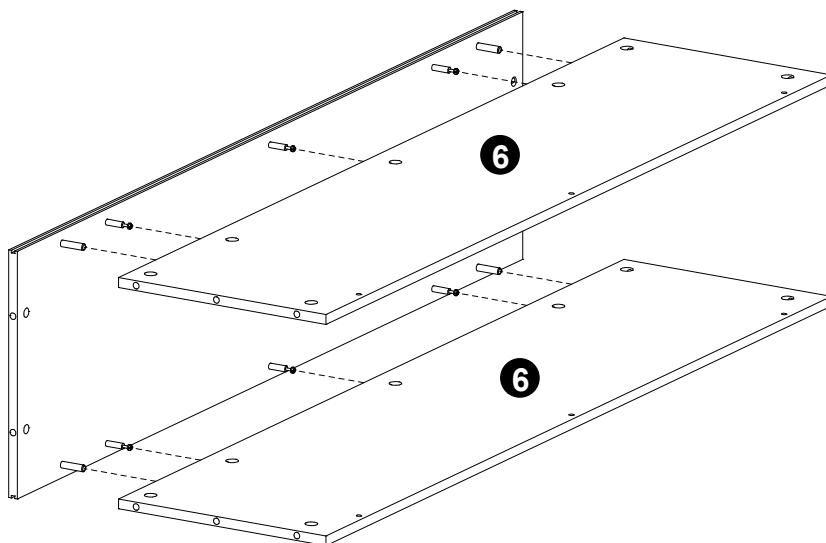
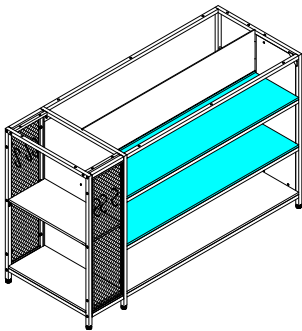

5

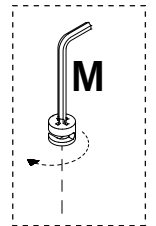
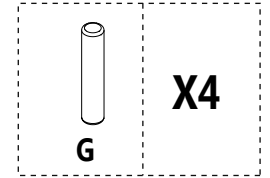
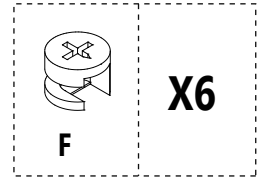
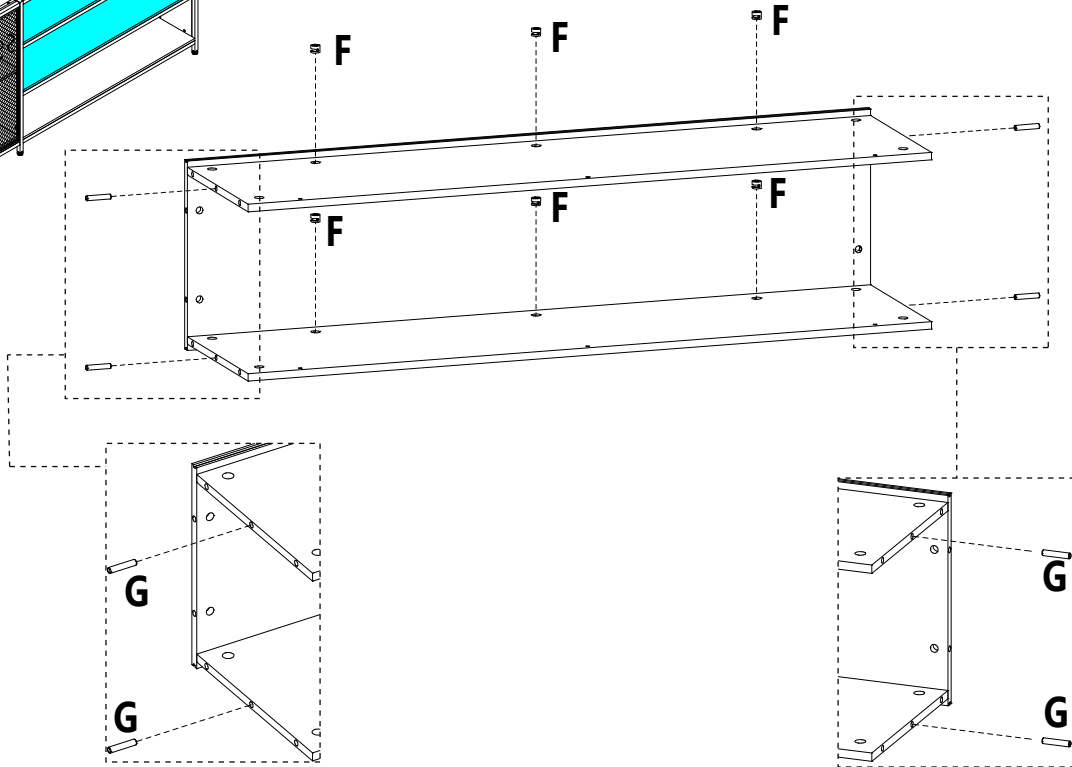
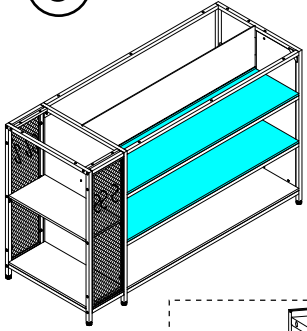

6

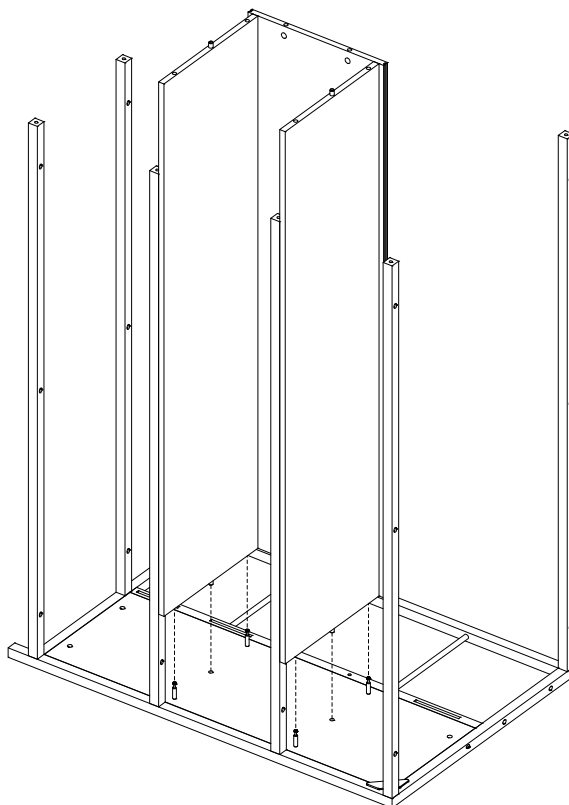
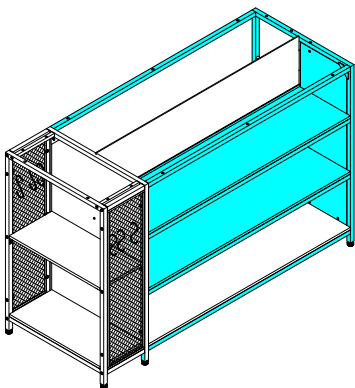

7

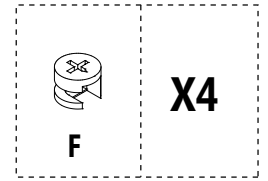
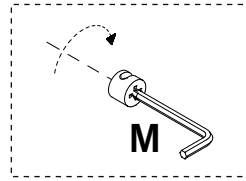
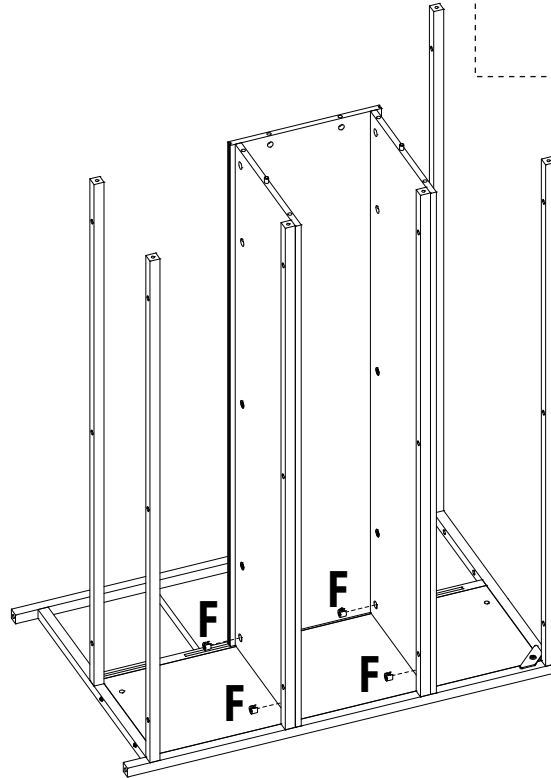
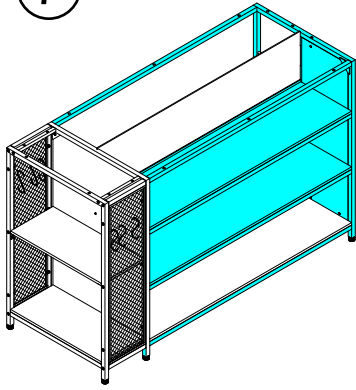

8

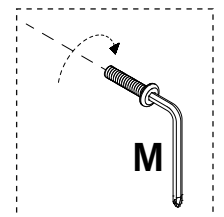
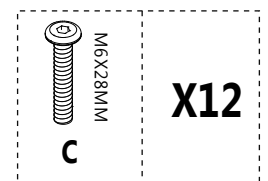
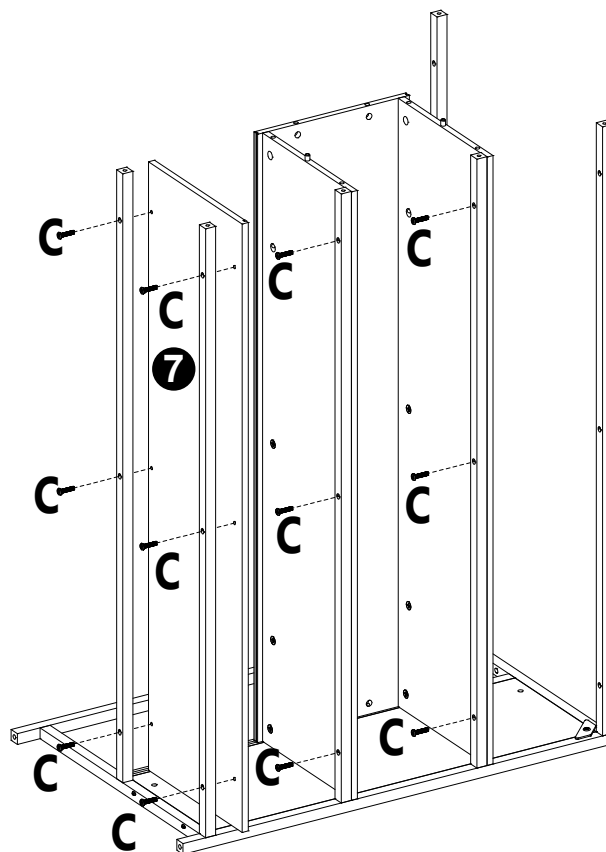
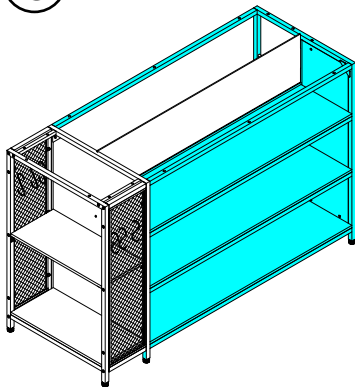

9

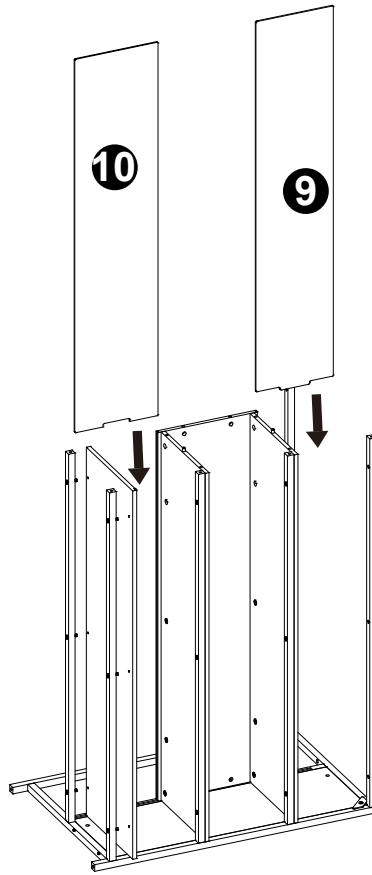
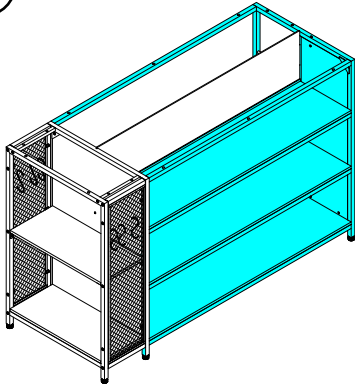

10

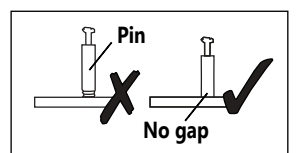
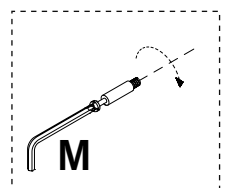
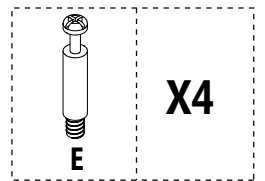
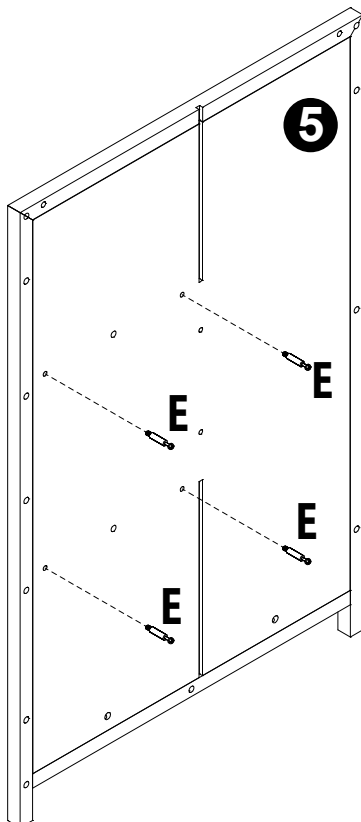
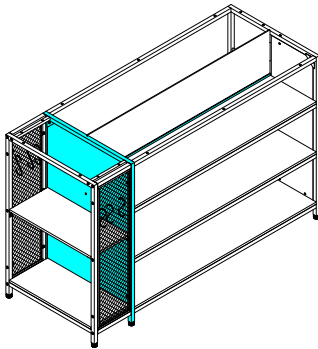

11

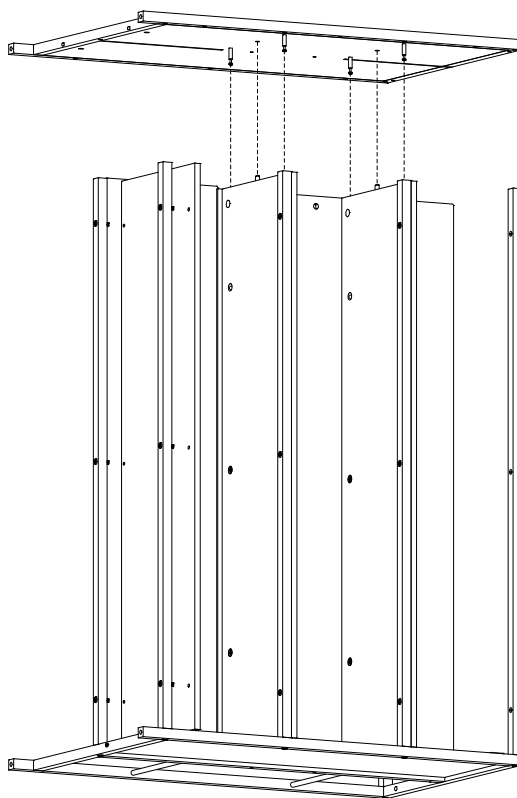
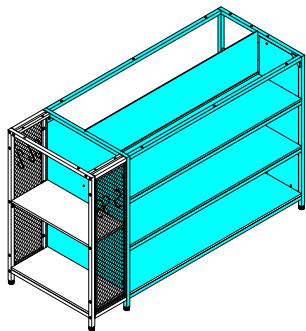

12

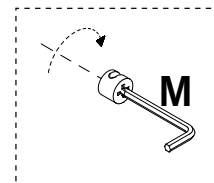
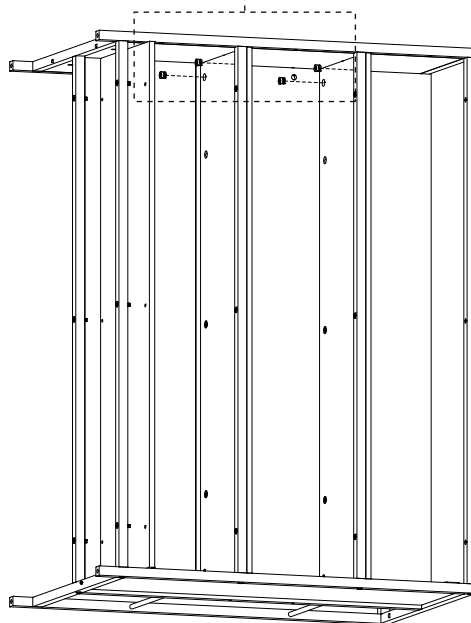
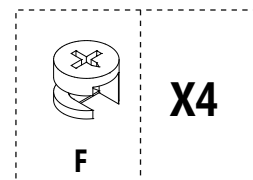
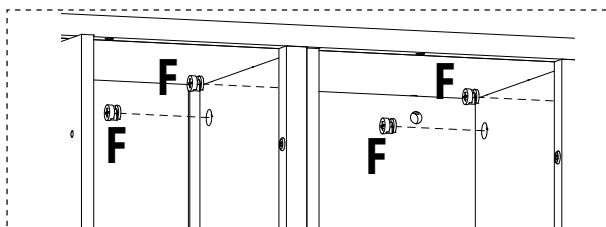
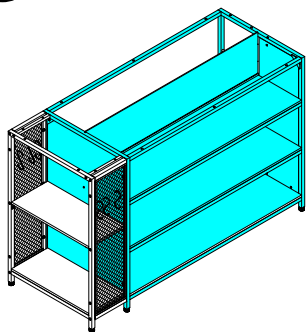

13

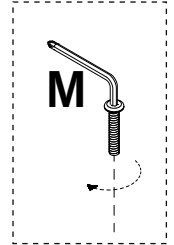
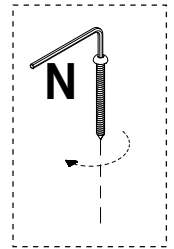
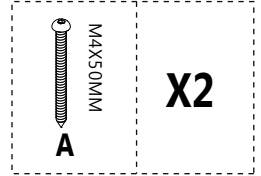
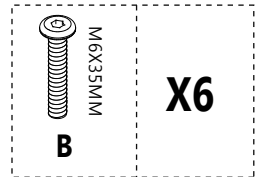
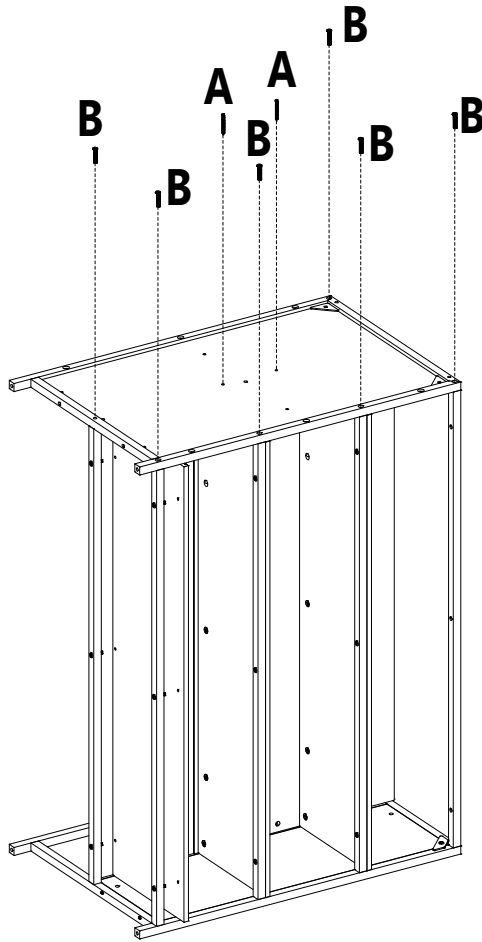
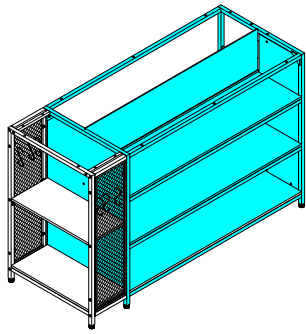

14

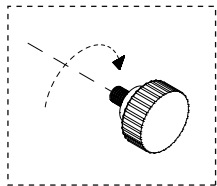
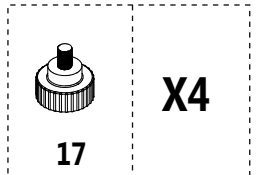
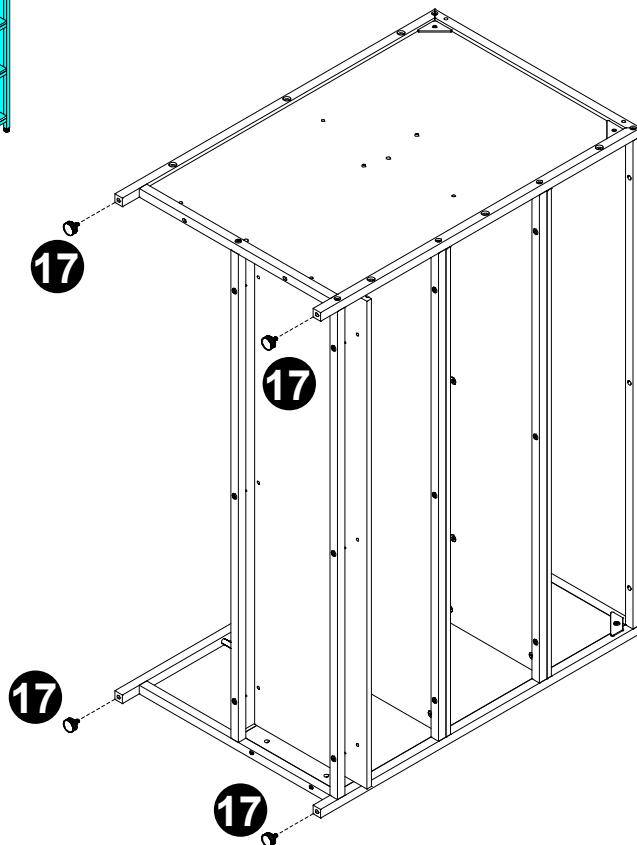
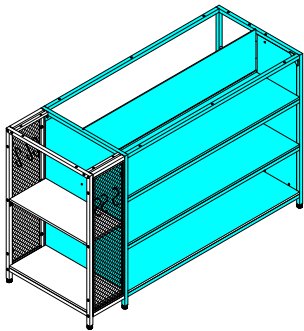

15

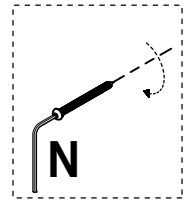
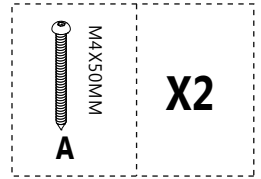
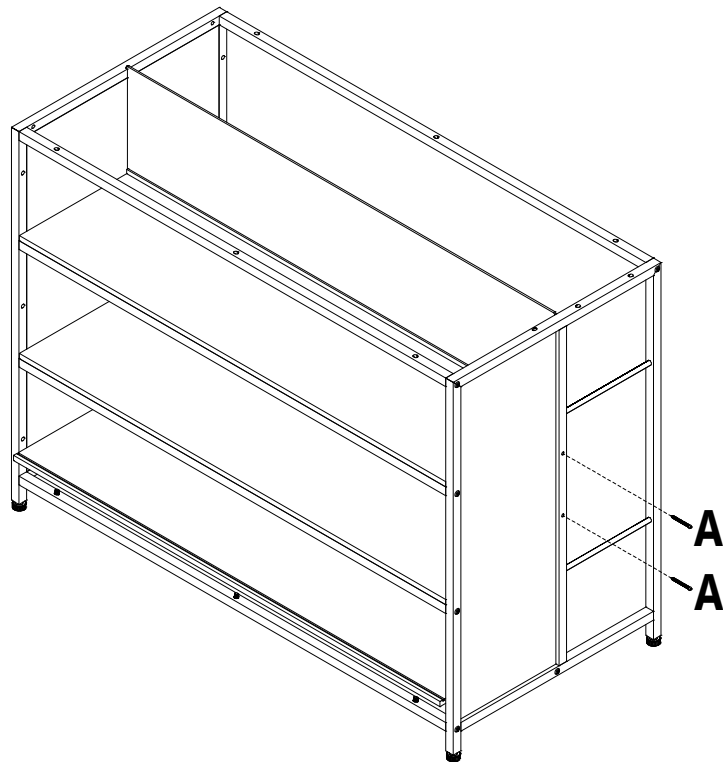
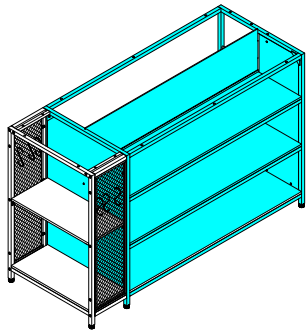

16

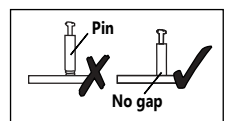
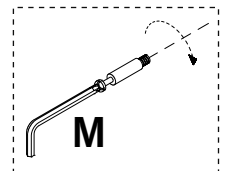
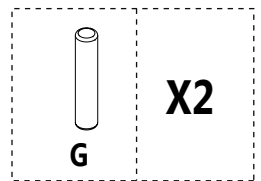
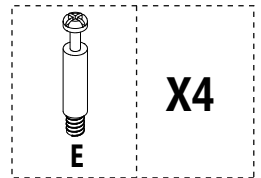
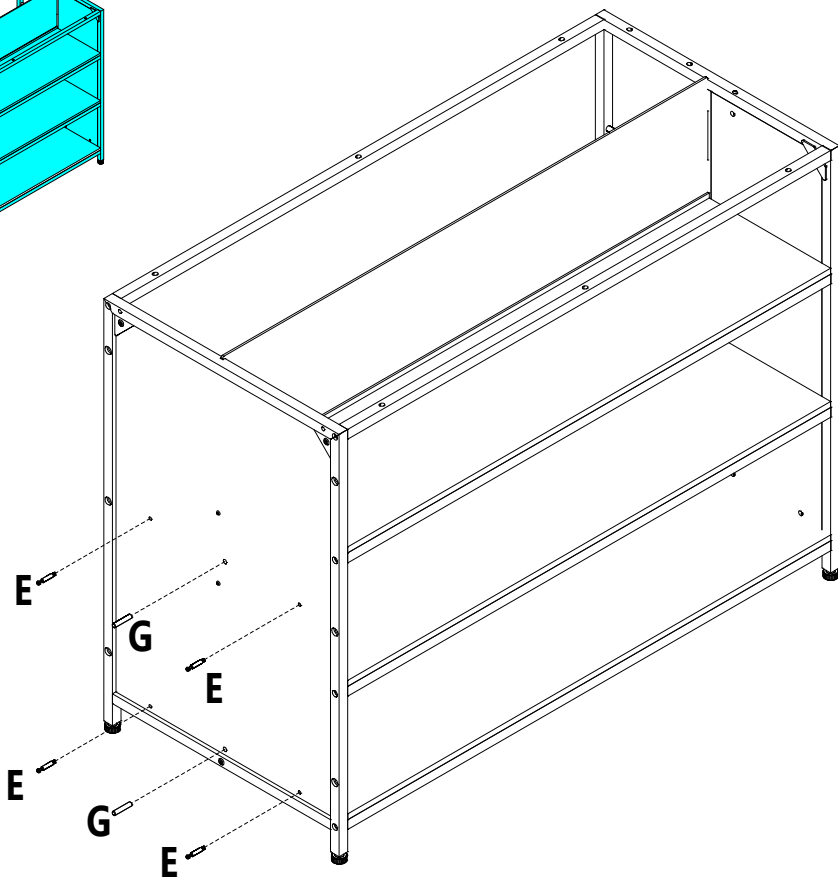
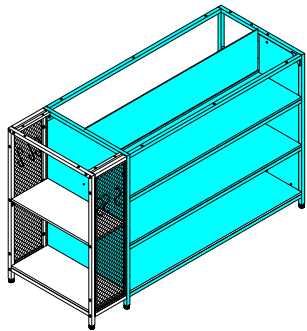

17

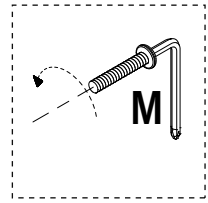
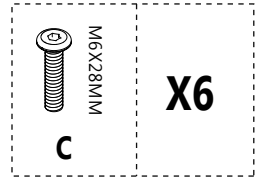
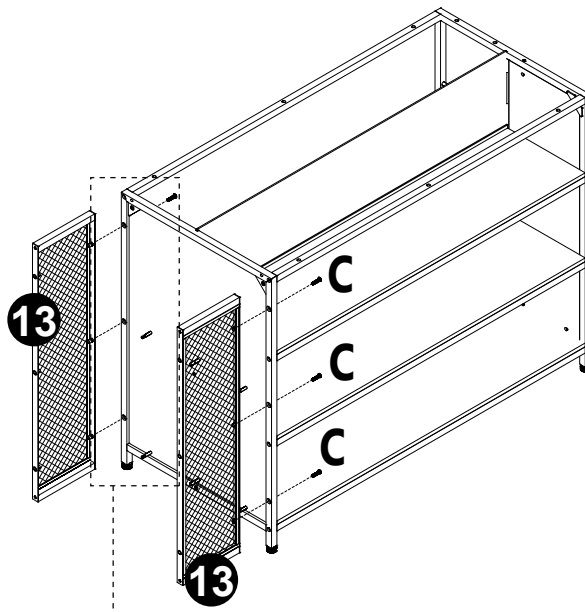
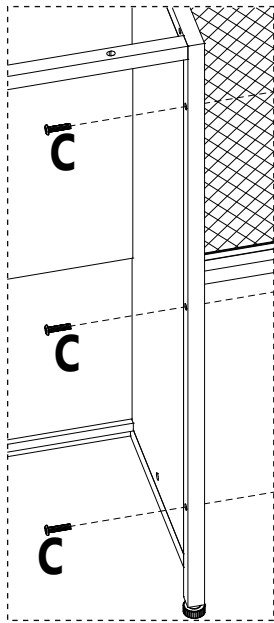
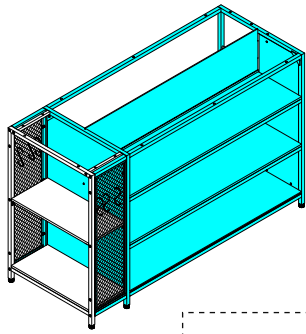

18

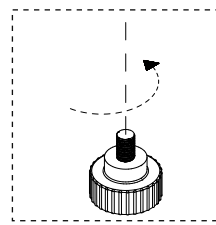
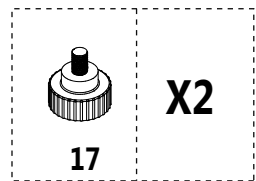
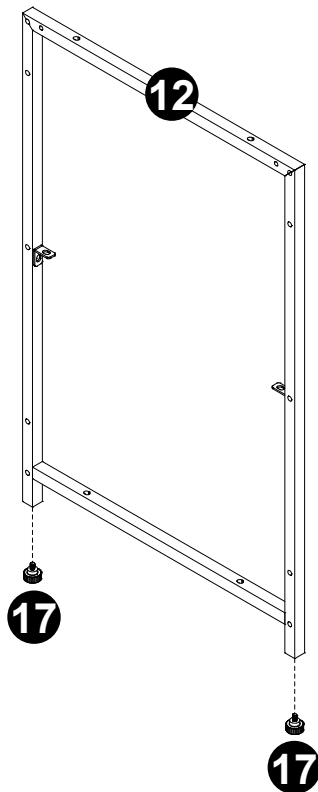
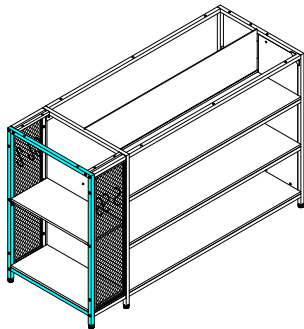

19

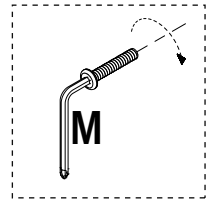
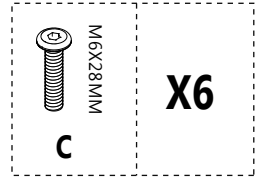
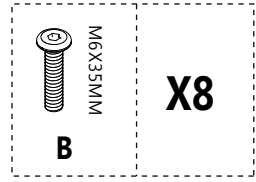
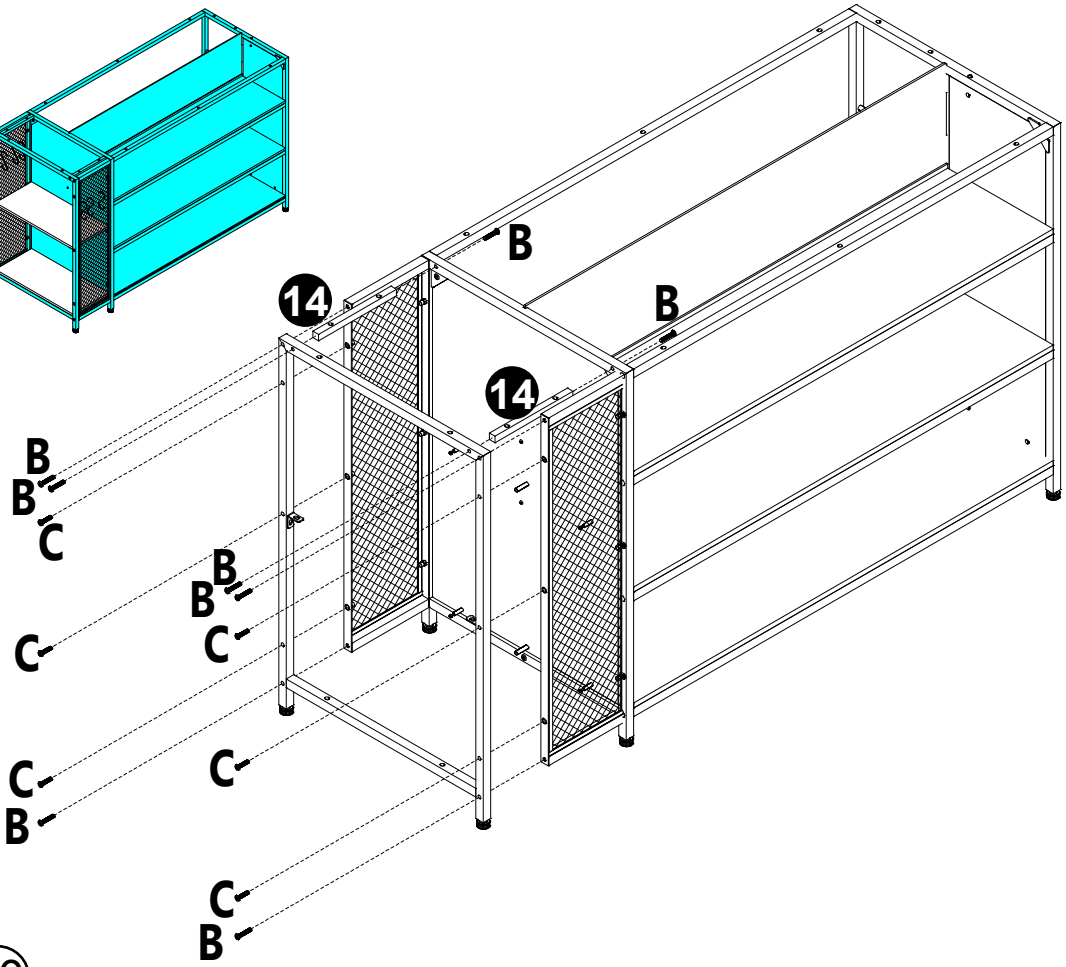
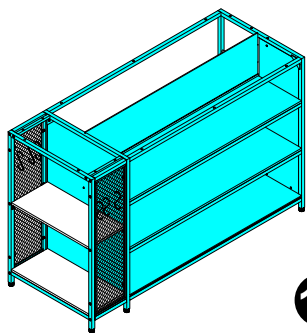

20

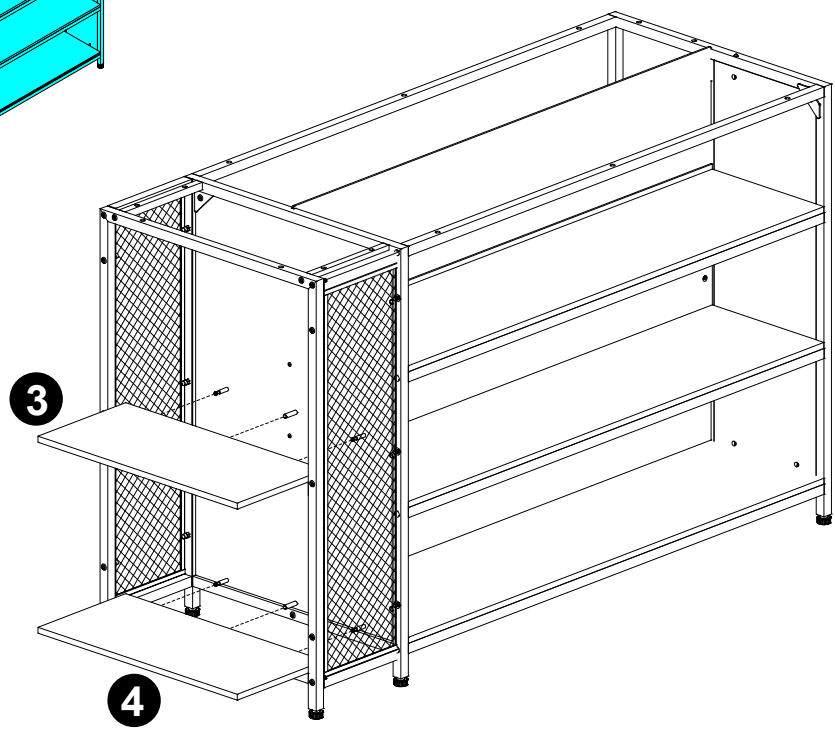
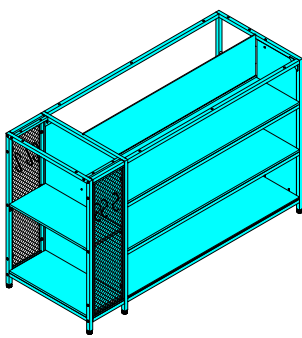

21

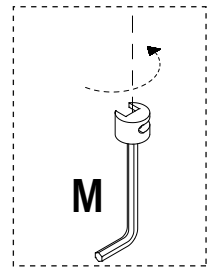
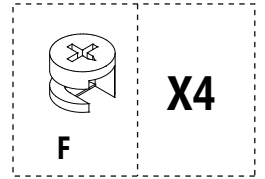
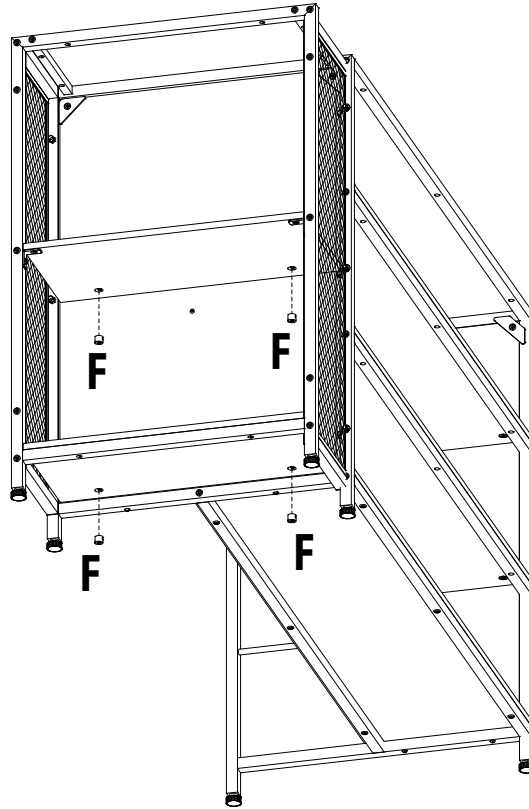
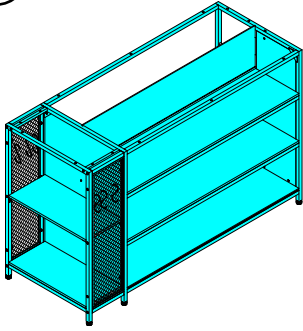

22

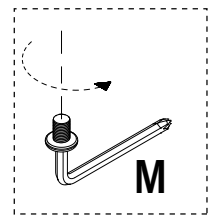
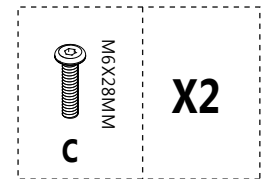
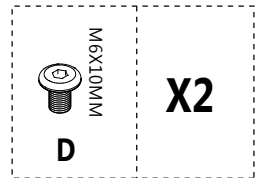
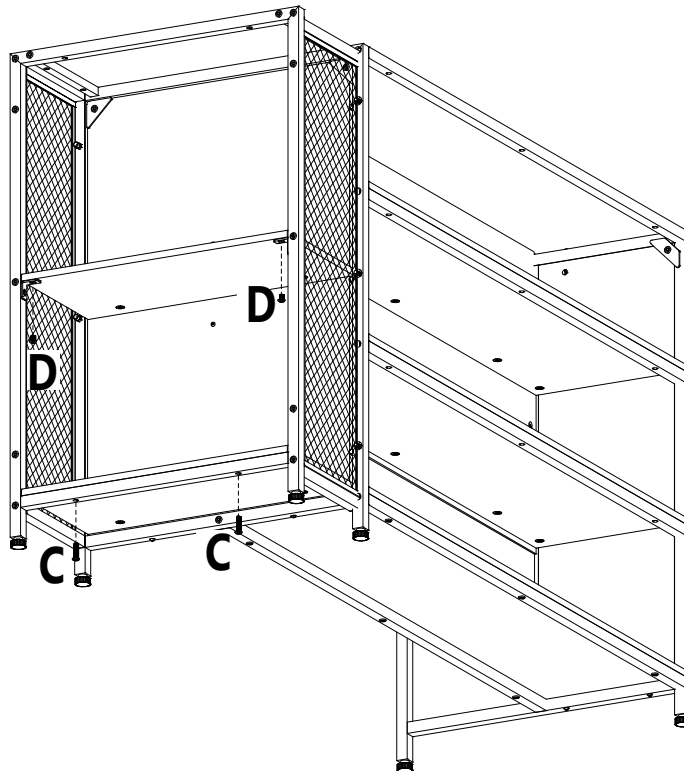
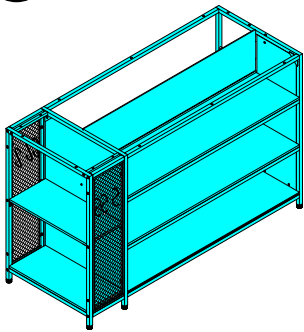

23

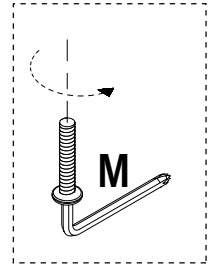
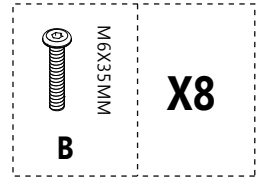
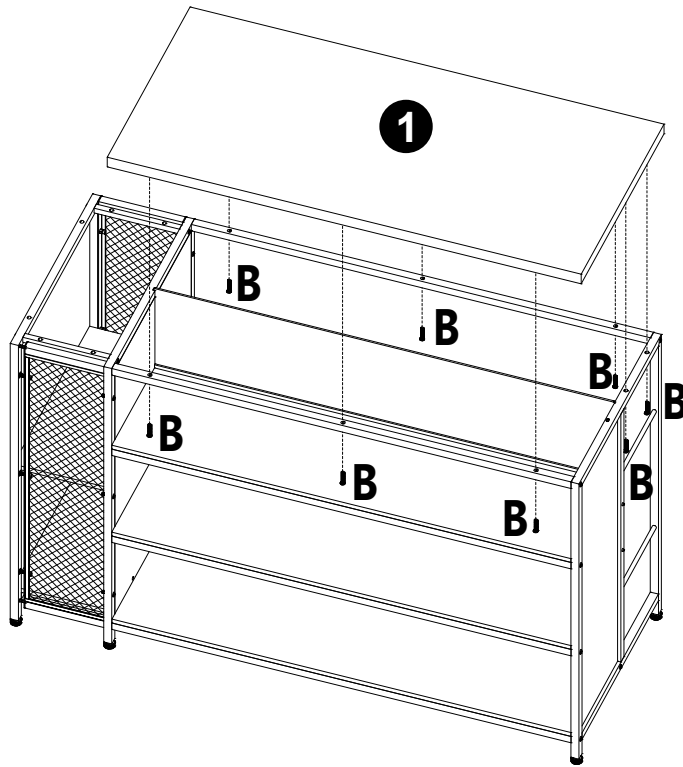
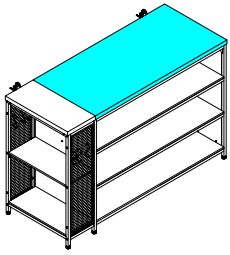

24

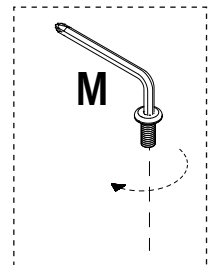
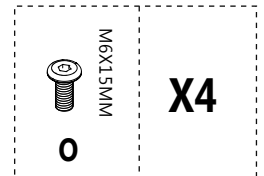
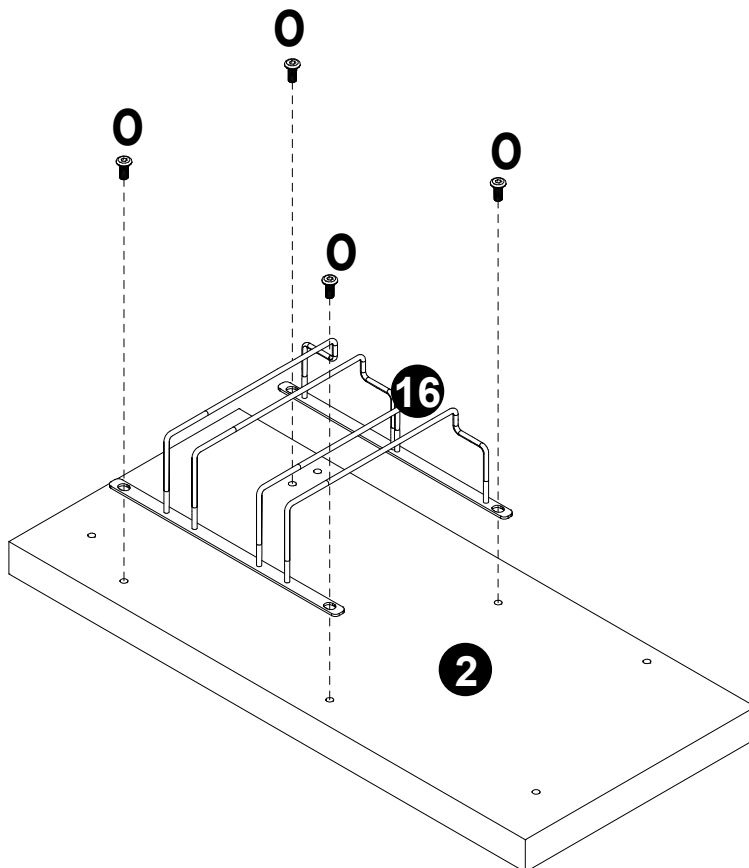
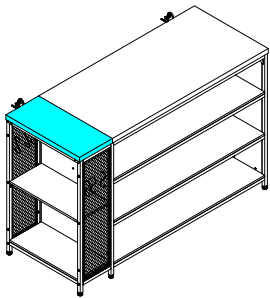

25

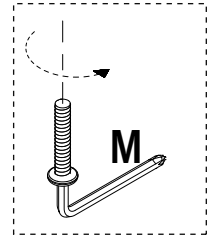
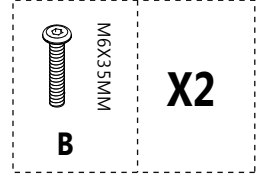
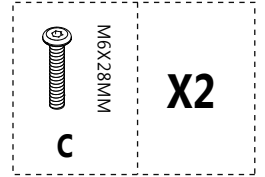
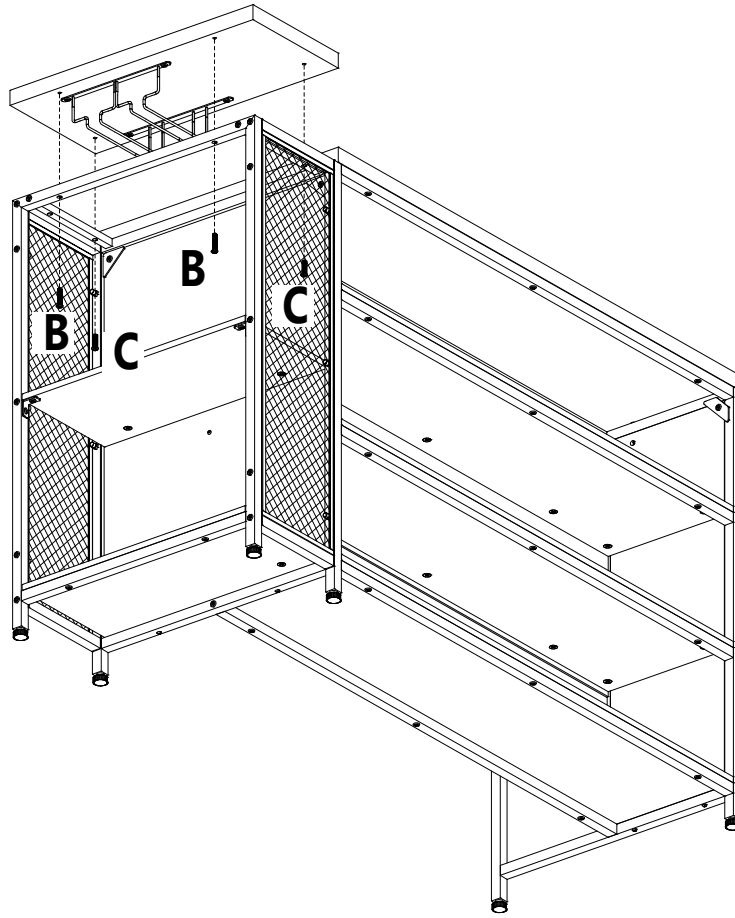
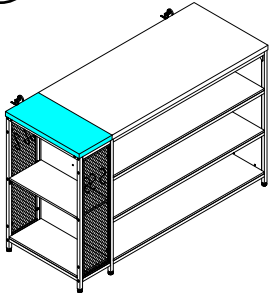

26

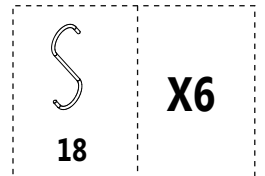
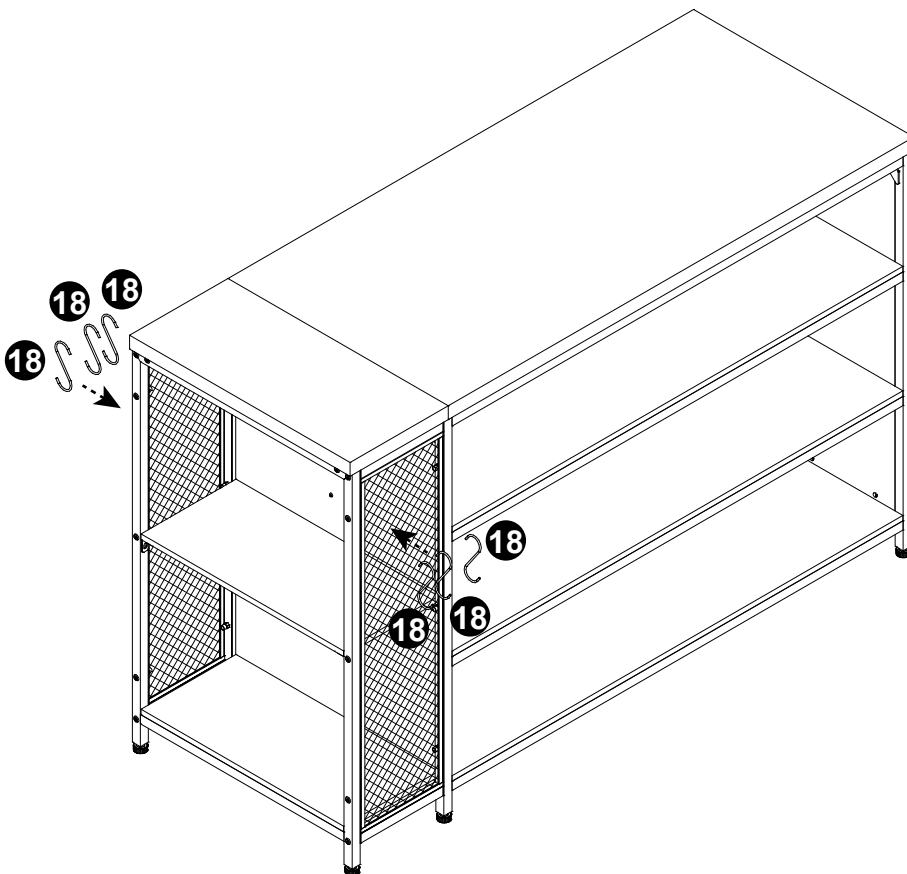

27

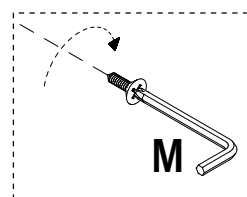
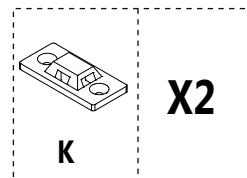
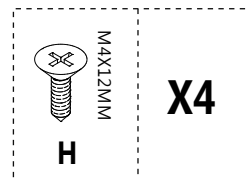
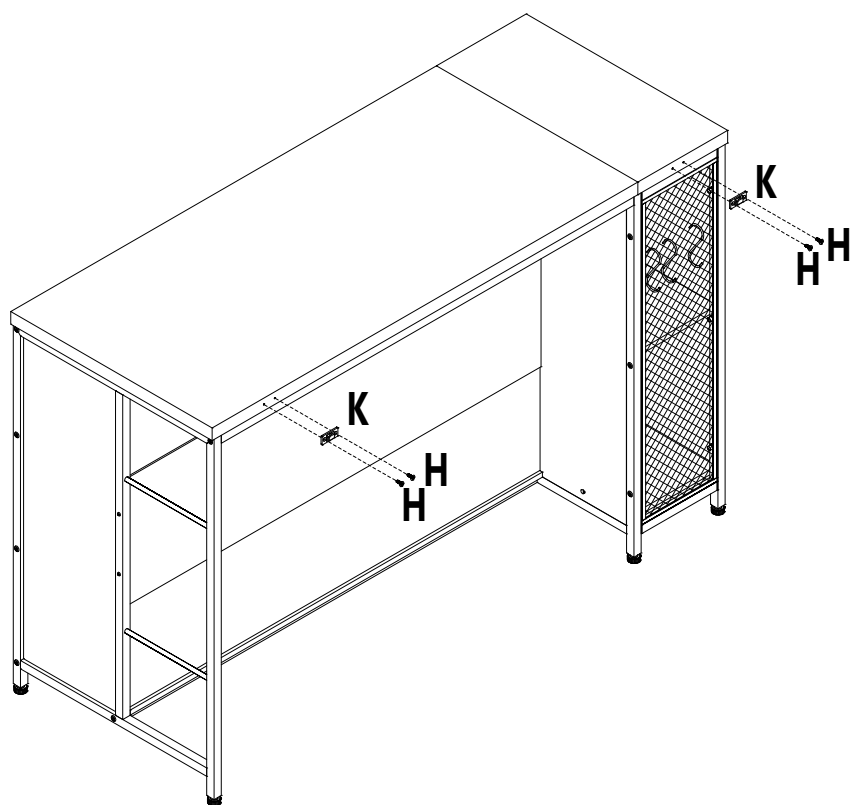

Give the same to the left

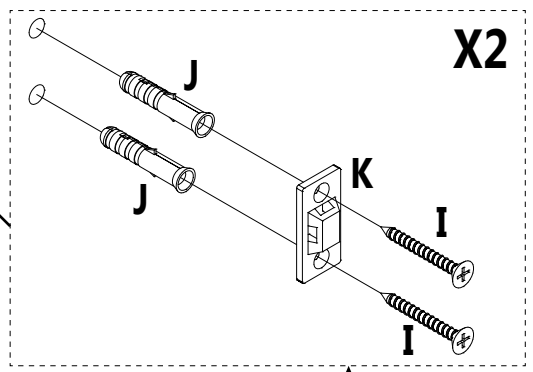
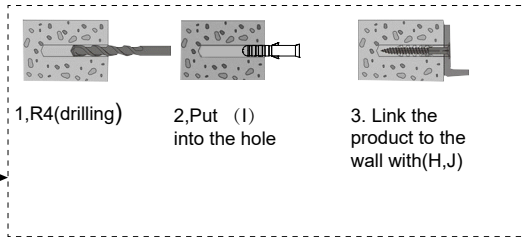
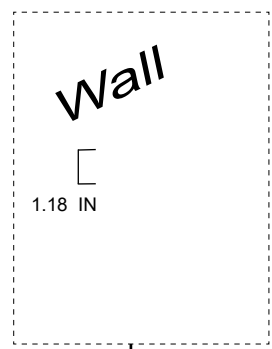
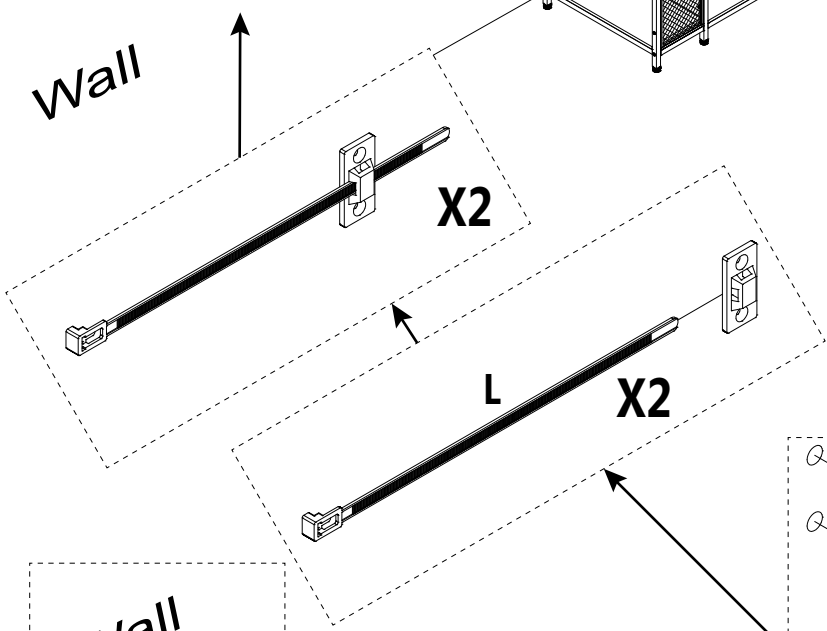
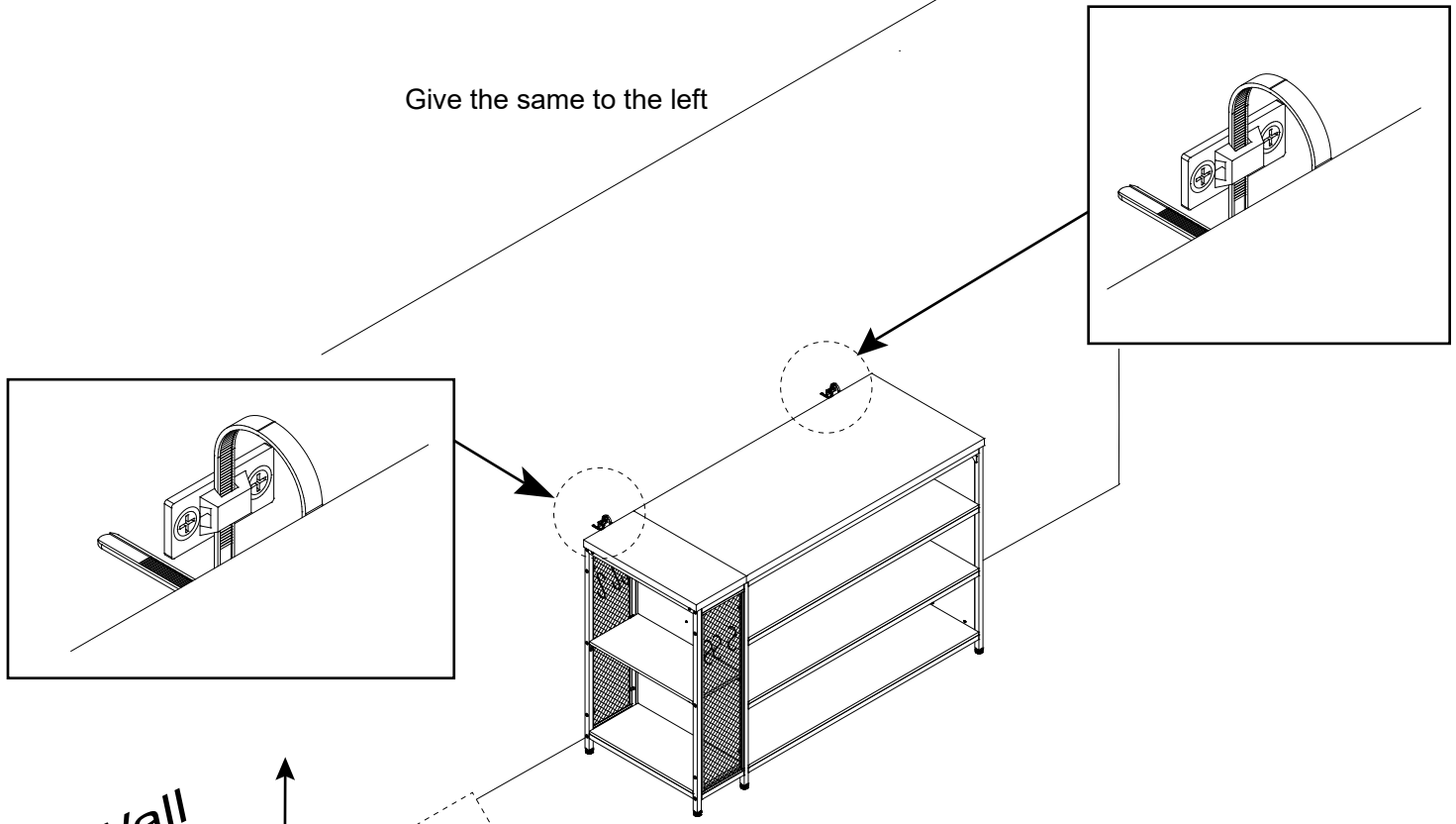

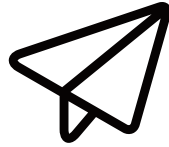

No heartburn, when we handle the return

Our way



YDS13538281408@163.com



Replacement/Refund



You

Their way



Re-package item



Schedule pick-up



Track package



Replacement



You

Contact our customer service team



YDS13538281408@163.com