

ASSEMBLY INSTRUCTIONS

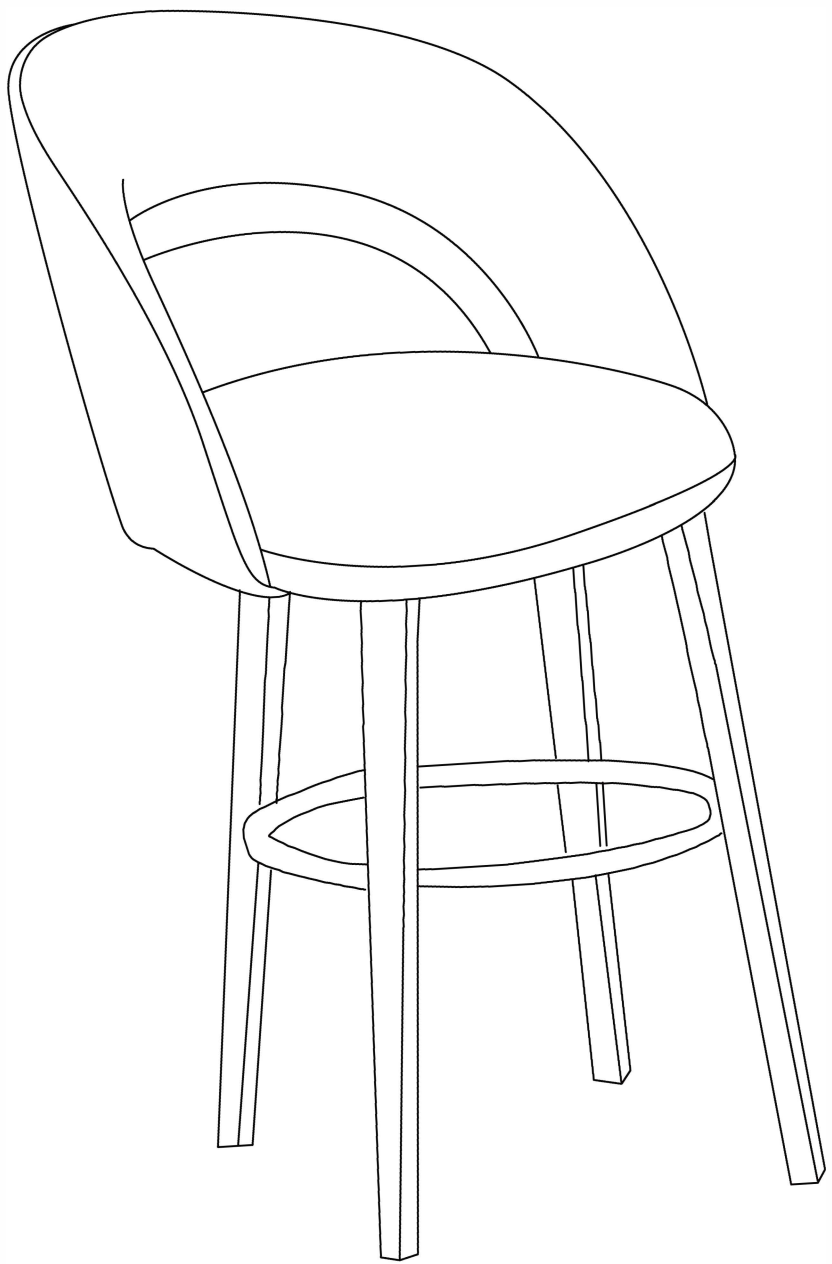

1

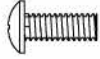

M6*20MM

G×10 + 1EXT



M6*16MM

H×2 + 1EXT



I×2



M6

J×1



K×1

SPARE PARTS

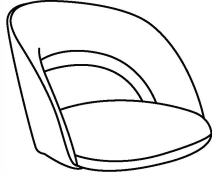

A×1



B×1

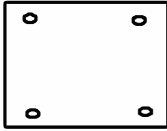

C×1



D×4

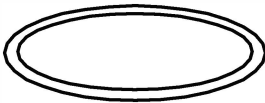

E×1

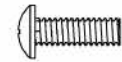

M6*30MM

F×4 + 1EXT

3



C×1



D×4



M6*20MM
G×4



M6
J×1

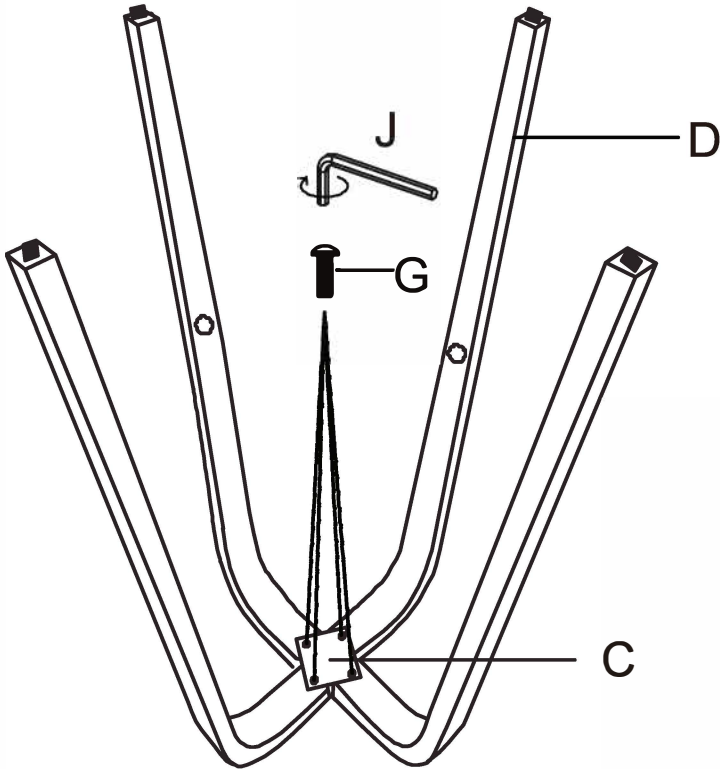
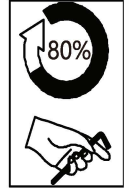

**Install the 4 screws G to 50% in sequence.
After all the four screws are installed,tighten them to 80%.**

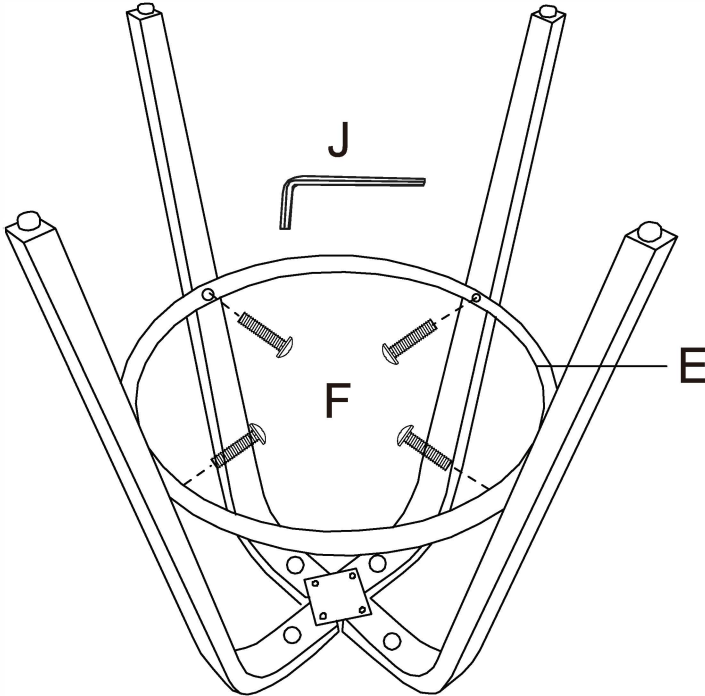
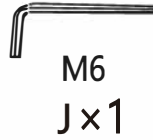
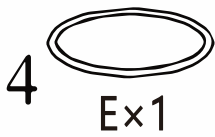

**Install the 4 screws F to 50% in sequence.
After all the four screws are installed, tighten them to 80%.**

5



B×1

Note:When installing the turntable, please rotate the turntable 45 degrees.

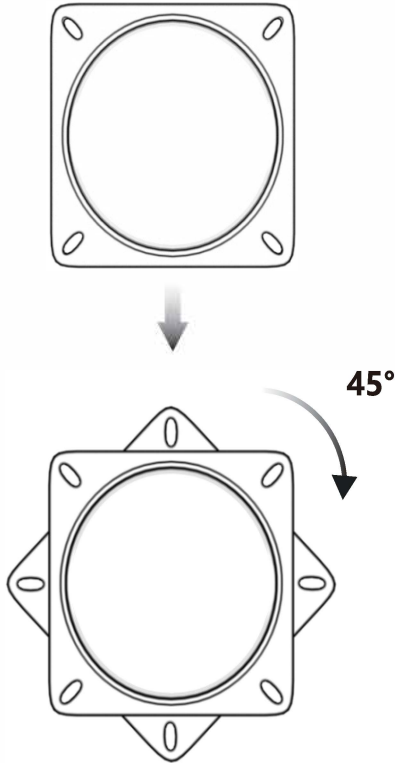

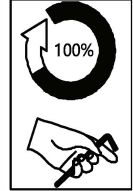
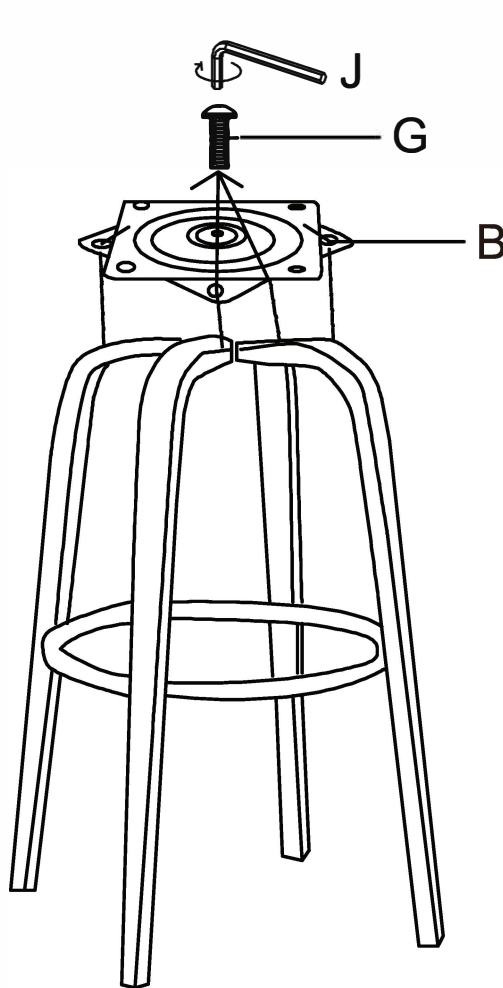
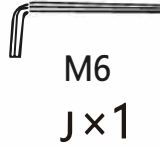
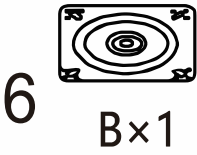

**Install the 4 screws G to 50% in sequence.
After all the four screws are installed,tighten them to 100%.**

Fasten All screws indicate on Step 1& Step2.

7 
1x2

Note:Accessories I should be placed at the front end,not at the back end

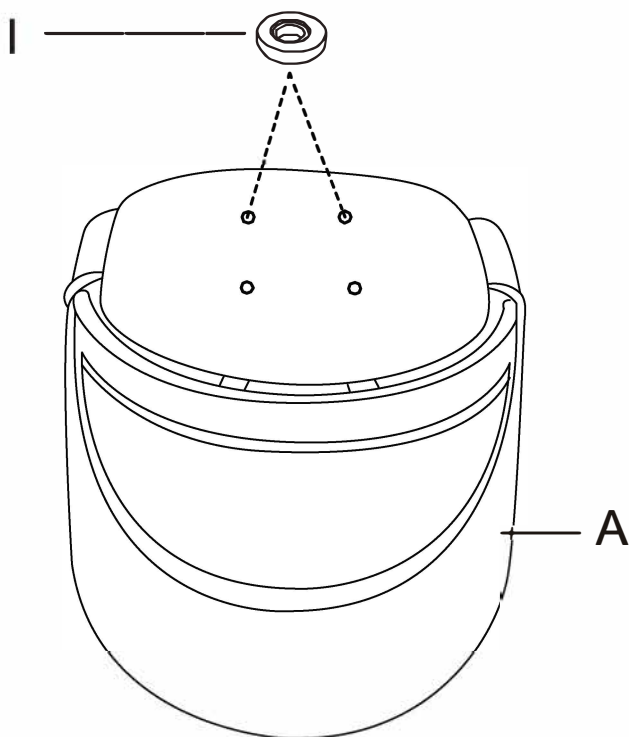

8



A×1



M6*20MM

G×2



M6*16MM

H×2



I×2



M6

J×1

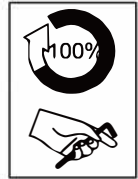
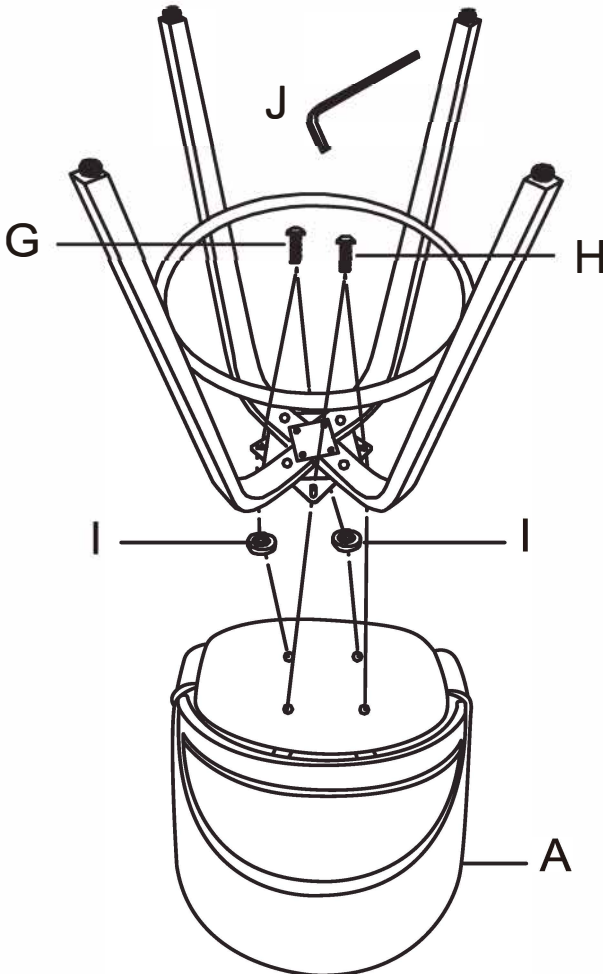

Install the 4 screws G and H to 50% in sequence.
After all the four screws are installed,tighten them to 100%

9



K×1

If you feel that the chair is not balance you can adjust the foot nails to level according to your needs.

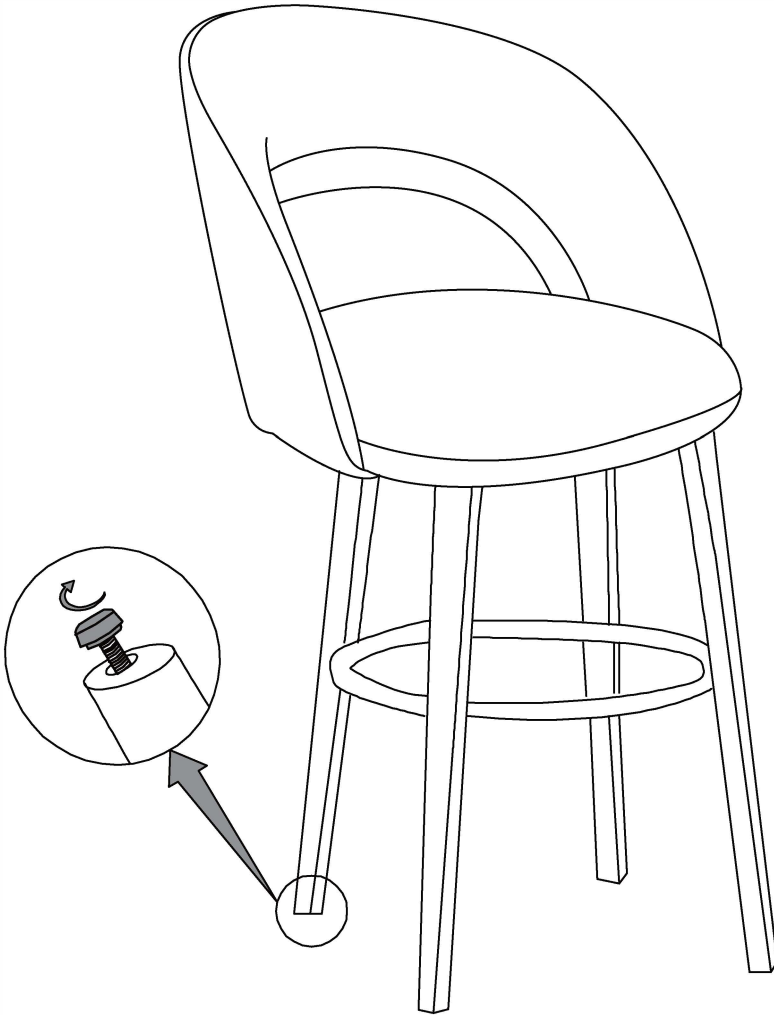

Be sure to keep spare parts.

If screws or nails of a product are damaged or lost, or screws or nails of a subsequent product are damaged or aged, spare parts can be used to replace them.