

Attendance access control integrated machine Quick Installation Guide

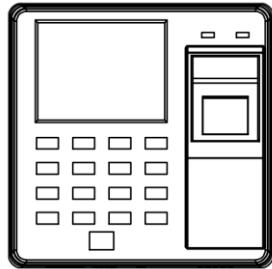

Due to the continuous updating of this product, our company does not promise that the actual product is consistent with the data, and does not assume any disputes caused by the actual technical parameters and the data does not match.

V4.4

1、 Installation Equipment (Wall Mounting)

- 1、 Remove the bottom screw with a screwdriver.
- 2、 Remove the rear cover from the device.

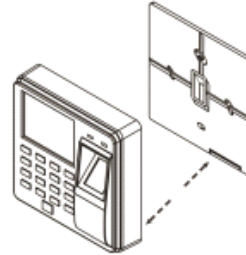

- 3、 Align the holes drilled in the wall and fix the rear cover to the wall with screws.
- 4、 Install the unit on the fixed rear cover.

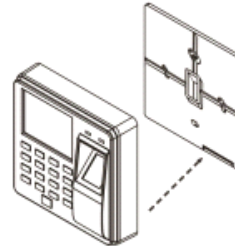
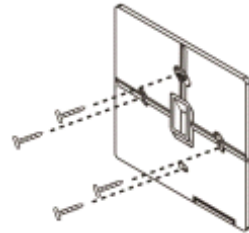

- 5、 Fix the device on the rear cover and lock it with screws.
- 6、 Tamper switch

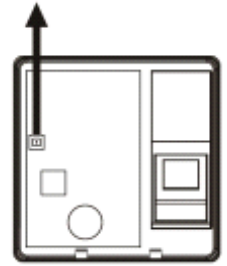

2、 Access Control Interface Definition

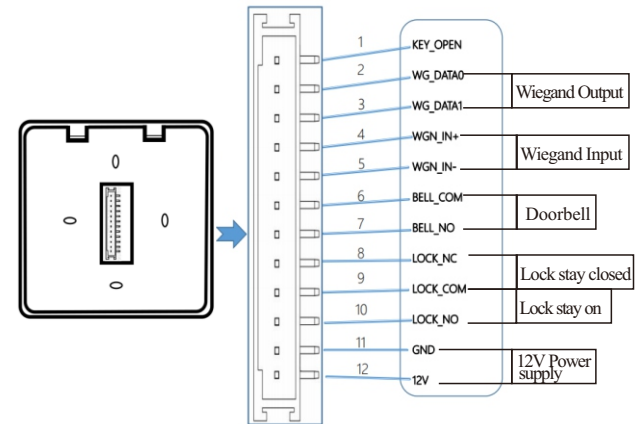

Process Of Using Attendance Machine For The First Time

Shift Setting→Dept.→Enroll→Employee Attendance→View Attendance Report

3、 Key Configuration and Input Method Description



- ESC Cancel or exit current settings
- MENU Enter menu management (delete key after entering menu)
- OK Confirm the current settings
- # Switching Input Method
- ▲ Move the cursor up
- ▼ Move the cursor downward
- 0-9 Input Number and 26 English Letters
- 🔔 Doorbell function

4、 Shift Setting

Shift 1				
	Hour	Min	Hour	Min
Time 1	08	00	12	00
Time 2	14	00	17	00
Overtime	18	00	20	00

- Press(MENU) enter main menu,press ▼to select“attendance setting”,→“shift setting”→“shift 1”(Up to 10 shifts can be set)
- OK →enter the shift modification interface→▲▼to select the period to be modified→OK to enter the work time and off time→ OK to confirm and save→ESU to return to the superior menu after editing.
- For example, if the company's working hours are: morning check-in time 08:00, afternoon check-out time 18:00, attendance twice a day. Shift setting as below:

Time1:8:00-18:00
Time2:0:00-0:00
Over time:0:00-0:00

Note: The default is shift 1

5、 Department Setting

Department	
1.Dept. 1	Not Set1
2.Dept. 2	Not Set2
3.Dept. 3	Not Set3
4.Dept. 4	Not Set4
5.Dept. 5	Not Set5

Dept. 1						
Week	Mon	Tue	Wed	Thu	Fri	Sat
01	01	01	01	01	01	01

Schedule: +10 Shift, empty/0-holidays

6、 Attend.Rules(If You Use The Default Attendance Rules, You Do Not Need To Change Any Settings)

Attend.Rules	
1. Company	
2. Shift	
3. Department	
4. Scheduling	Department
5. Attend. Time Allowed	

7、 Employee Registration

Enroll	
ID	000001
Name	
Dept.	Not Set1
Enroll	

- Department setting
Press(MENU)enter main menu,press ▼to select "attendance settings",press(OK)to enter,press▼to select "department settings",press(OK)to enter the modification department interface,use the Digital key to enter the name of the department, press the OK key to save.

- Shift (Menu→Attendance Setting→Department Setting→Department →Shift)
Number 1~10 means shift 1 to shift 10, 0 means off;

Note: When the shift is complex or the department schedule cannot meet your demand, it is recommended to download attendance setting form to set the shift and schedule for employees.

- Press(MENU)enter main menu,press ▼to select “attendance settings”,It can set up the company name, shift arrangement, ringing time, allowable late arrival, early departure time and repeated invalid attendance time.

- Press(MENU)enter main menu,press OK to select “Employee Management”, press OK to select “Enroll”.
- After completing the required settings,press(ESC)save and exit.

Employee Info	
1.ID	000001
2.Name	0
3.Finger	0
4.Password	0
5.Dept.	Not Set1

ID :System default.(The worker number can be set up to 1000)

Name:Use the numeric keys to enter.

Finger:The fingerprint collector was pressed 3 by the same finger, and the fingerprint was registered successfully, Press MENU to delete the employee's fingerprint

Password:Password can be entered up to 6 digits, you can pass this step.

Dept.:press (OK) to select departments from the list.

Authority:press (OK) to select Jurisdiction from the list.

8、 Download and view attendance reports

Menu		
Employee	Attendance	Attend. Rules
Log Query	Setting	About

Attendance	
1. Download All Report	
2. Download Individual Report	
3. Download Employee Form	
4. Upload Employee Form	
5. Download Employee Data	

- Insert U disk into machine's USB slot;
- Press(MENU)enter main menu, press ▼ select “attendance”.
- press(OK)enter,press ▼ select reports you want to download,Press the [OK] key to enter the report download interface, enter the time period, and press the [OK] key to download.

Warm Tip:

Please use FAT32 format U disk, if the attendance machine can not recognize your U disk, please first convert the U disk into FAT32 format, and then operate.

9、 Quick inquiry of staff attendance record instructions

- ID Query:Steps: Menu→Records Query→ID Query→Browse/Download→Enter ID→OK to confirm
- Time Query:Steps: MENU→Log Query→Records Query→Time Query→Browse/Download.