

Installation & Assembly

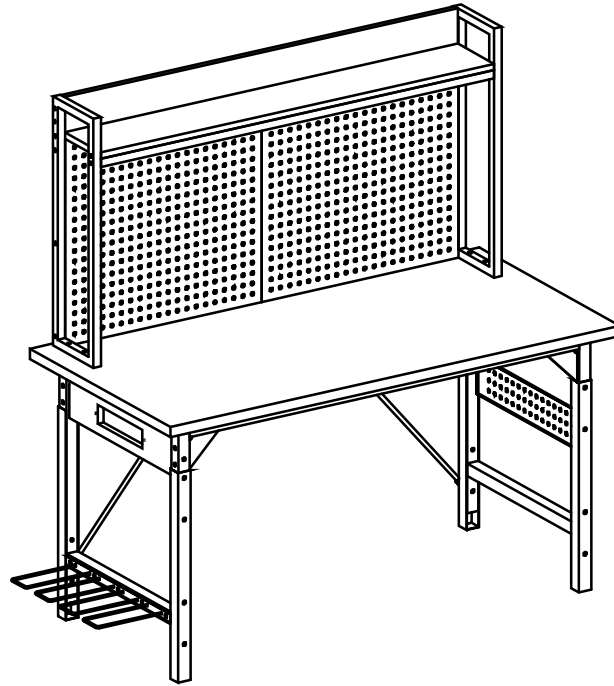

I

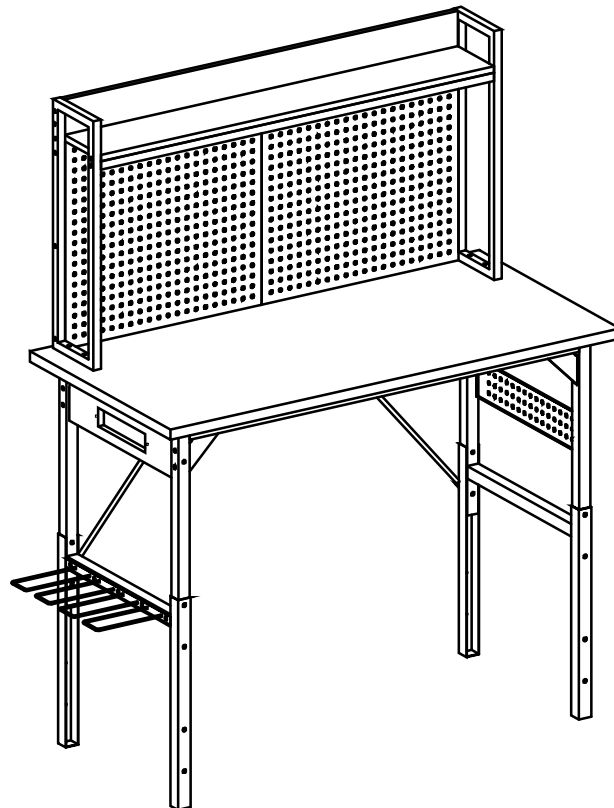

II

General Guidelines

- Please read the following instruction carefully and use the product accordingly.
- Please keep this manual and hand it over when you transfer the product.
- This summary may not include every detail of all variations and considered steps. Please contact us when further information and help are needed.

Notes

- The product is intended for indoor use only. The product must be assembled and used in accordance with the provisions of the manual. Personal injury and/or damage to product may occur if products are used outside of their intended purposes and/or if products have been changed/modified from their original design. The seller does not assume any responsibility or liability with respect to any injury/damage caused by incorrect assembly or improper use.
- Avoid long-term exposure to humid environments to prevent mildew.
- Keep the product away from fire sources and high temperatures. Do not expose the product to direct sunlight.
- Do not place any hot objects on the surface of the product.
- If there are any defective or missing parts after unpacking, please cease assembly immediately and contact us.
- Please assemble the item on a spacious surface and do not place the unwrapped product directly on the ground to avoid product damage.
- Please do not stand or sit on the wooden boards.
- Please wear gloves during the assembly and/or disassembly process to avoid scratches from any sharp edges.
- Please match the corresponding part and fitting based on the part number in the manual.
- If the part does not match with the fitting, please check the piece as specified in this manual.
- During assembly, first loosely align all screws with the corresponding pre-drilled holes and then tighten the screws one by one.
- Periodically inspect screw tightness while the product is in use. If necessary, retighten to ensure structural integrity.
- If you accidentally spill water or another liquid on the surface, immediately wipe clean with a dry towel.
- Please place this item on level, solid ground during use.

Warnings

- During assembly, keep all small parts out of the reach of children. It may be fatal if swallowed or inhaled.
- Children should not climb or play on the product in order to avoid tipping over the furniture and causing serious injury.
- To avoid the potential dangers of suffocation, please keep all parts and packaging (film, plastic bags, foam, etc.) away from babies and children.
- Keep sharp objects and corrosive items away from the product to avoid any damage or injury.
- Do not shake or move violently during use to avoid tipping over the product.

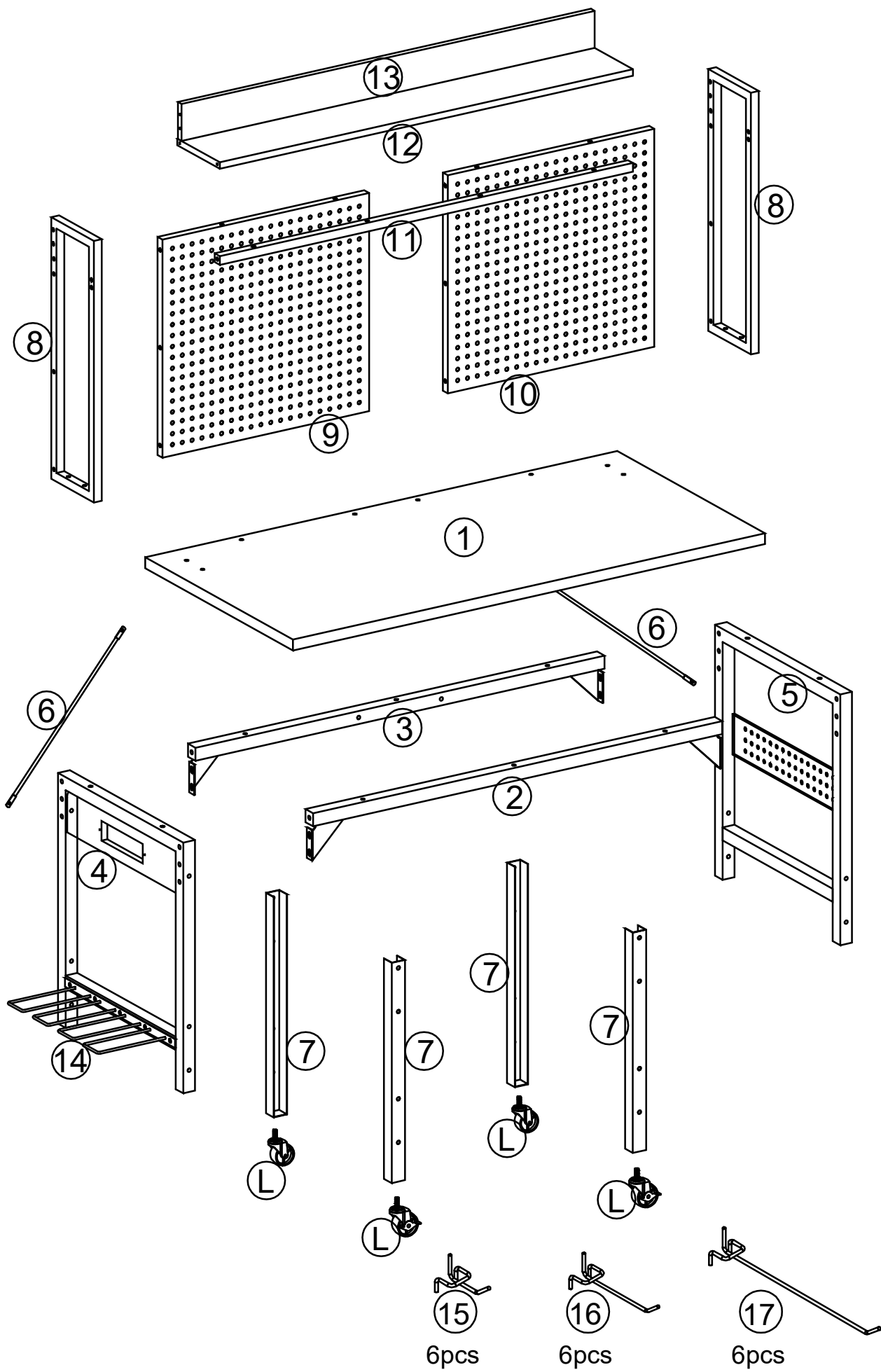

Part list

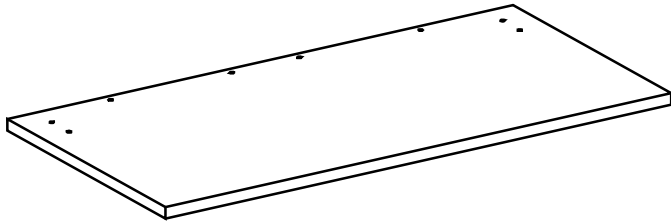

① X1

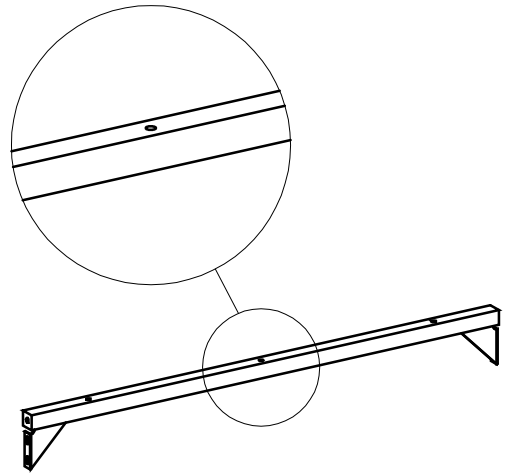

② X1

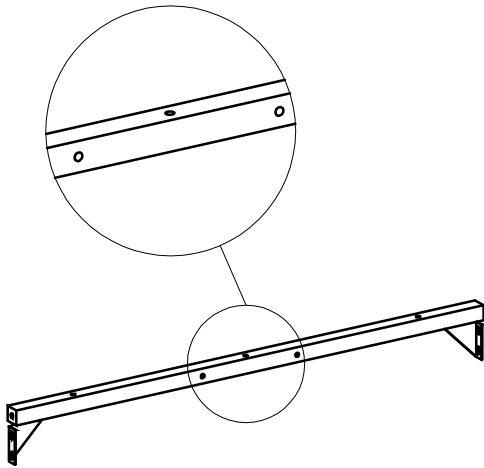

③ X1

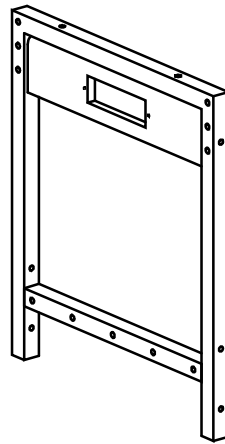

④ X1

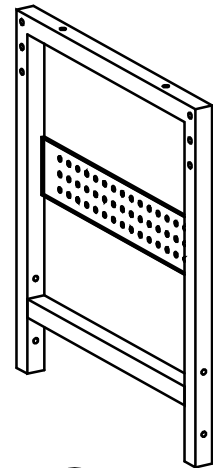

⑤ X1

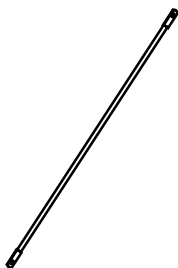

⑥ X2

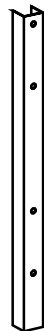

⑦ X4

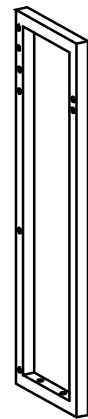

⑧ X2

Part list

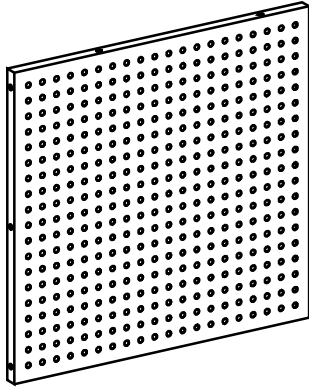

⑨X1

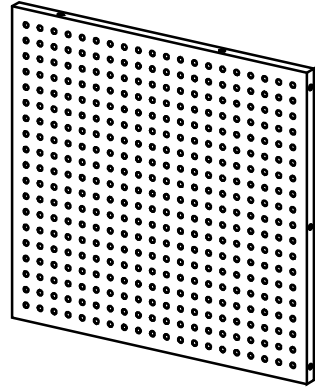

⑩X1

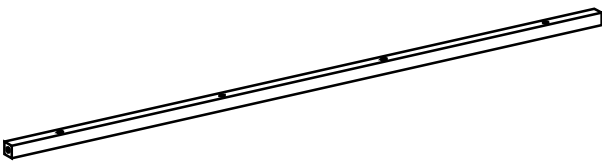

⑪X1

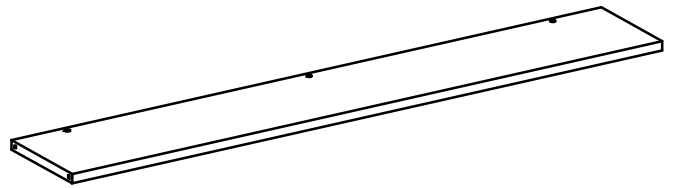

⑫X1

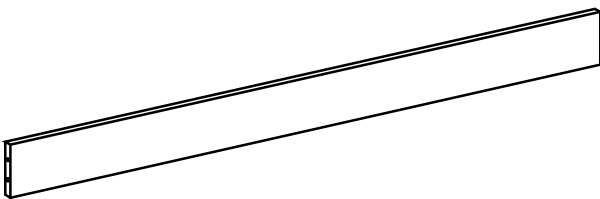

⑬X1

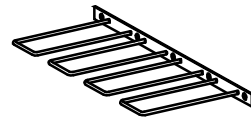

⑭X1



⑮
6pcs



⑯
6pcs

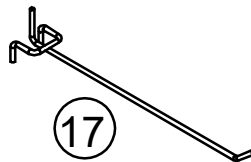

⑰
6pcs

Hardware list

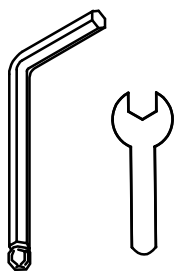

Ⓐ X1



Ⓑ X7+1

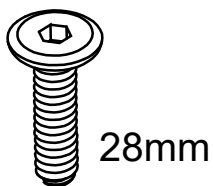

Ⓒ X14+1

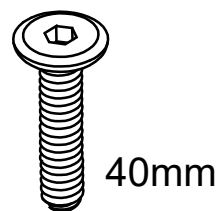

Ⓓ X33+2

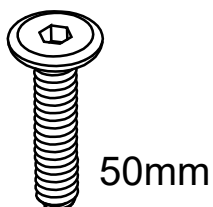

Ⓔ X4+1

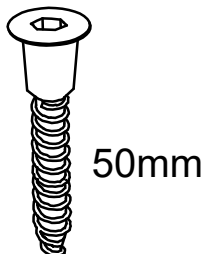

Ⓕ X12+1

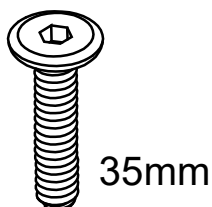

Ⓖ X4+1

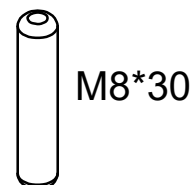

Ⓗ X3+1

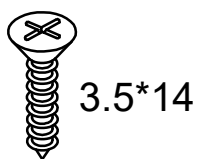

Ⓘ X2+1



Ⓙ X36+2



Ⓚ X4

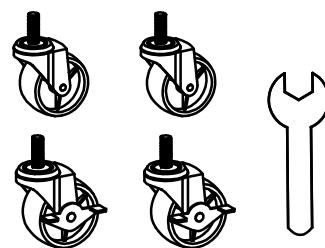

Ⓛ X1

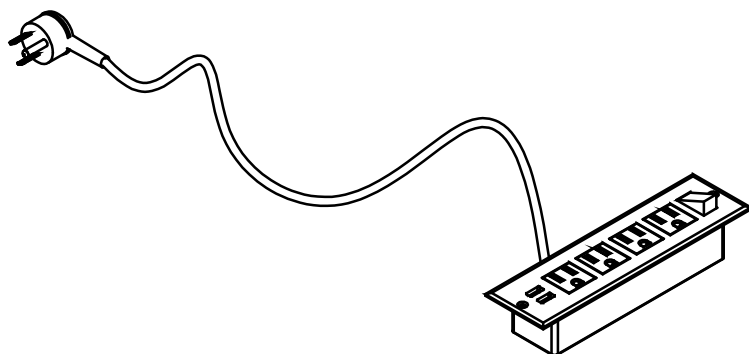

Ⓜ X1

1

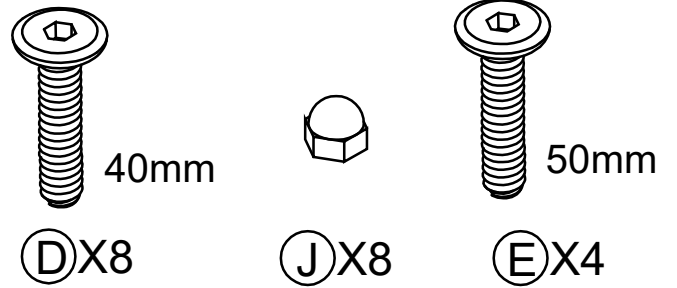
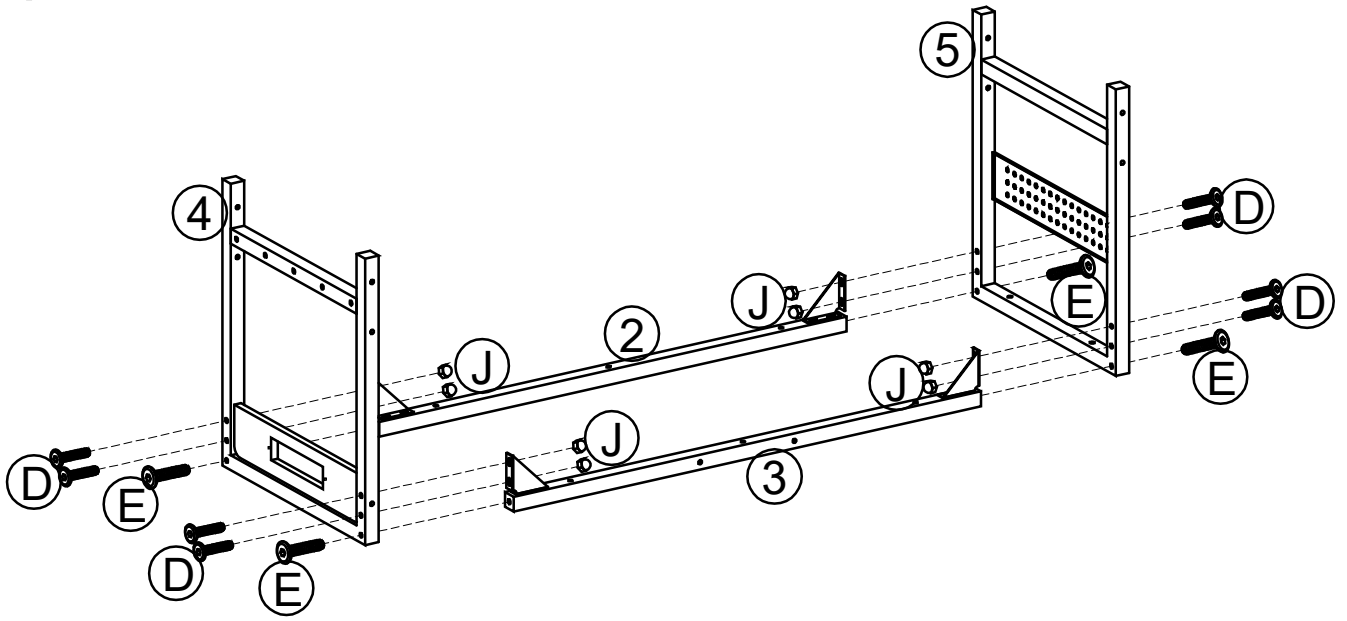

2

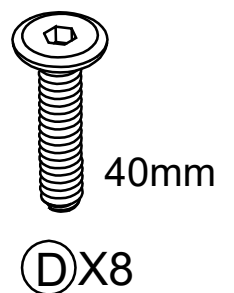
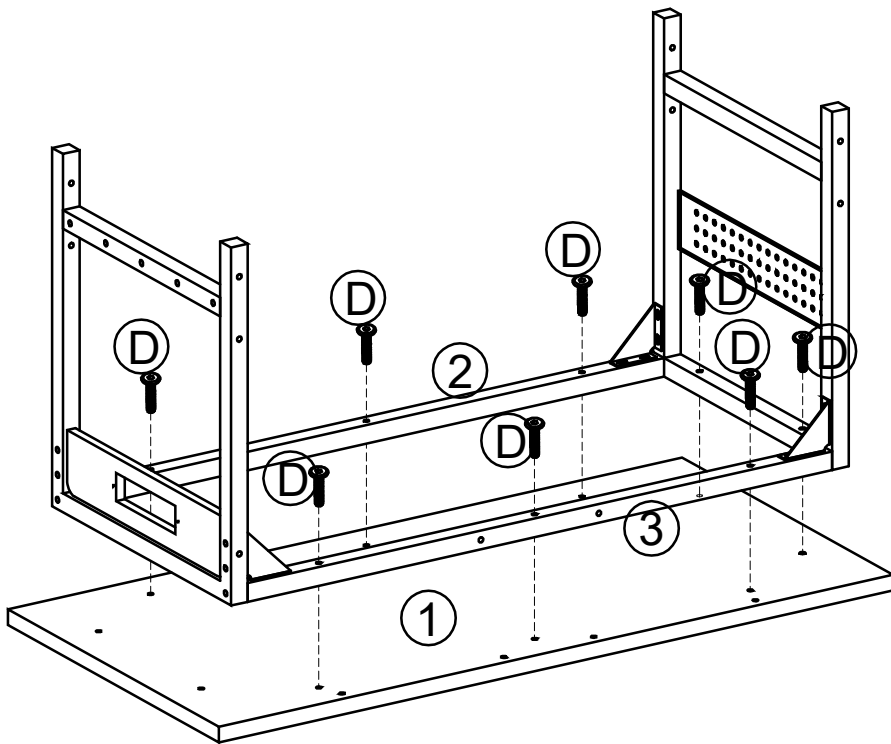

3

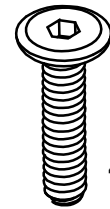
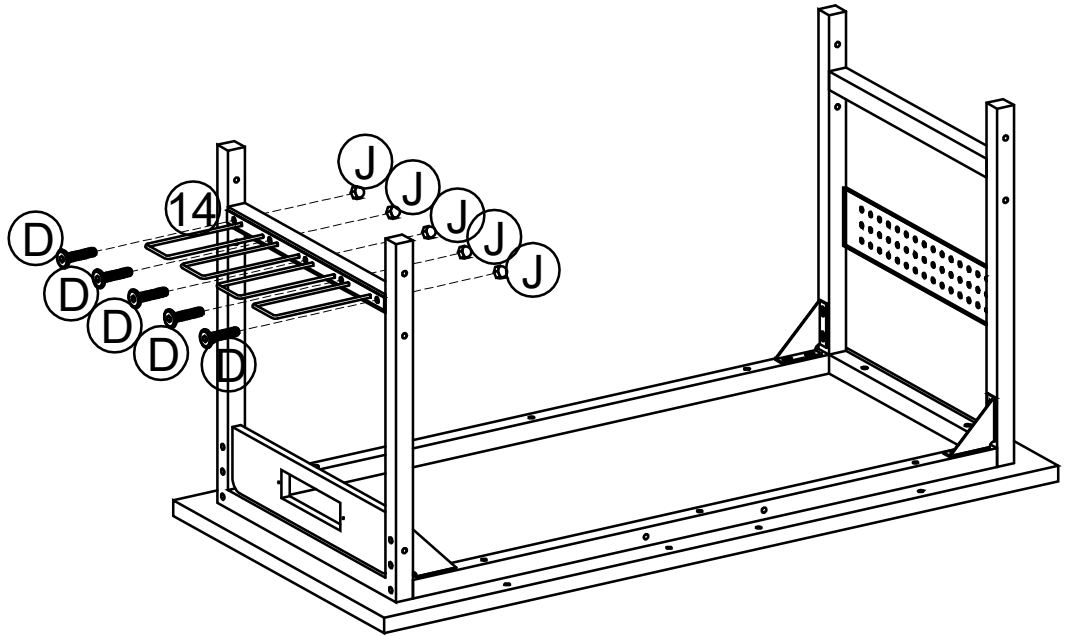

40mm



(D)X5

(J)X5

4

Install as required.

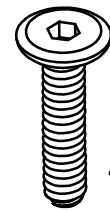

40mm



(D)X6

(J)X6

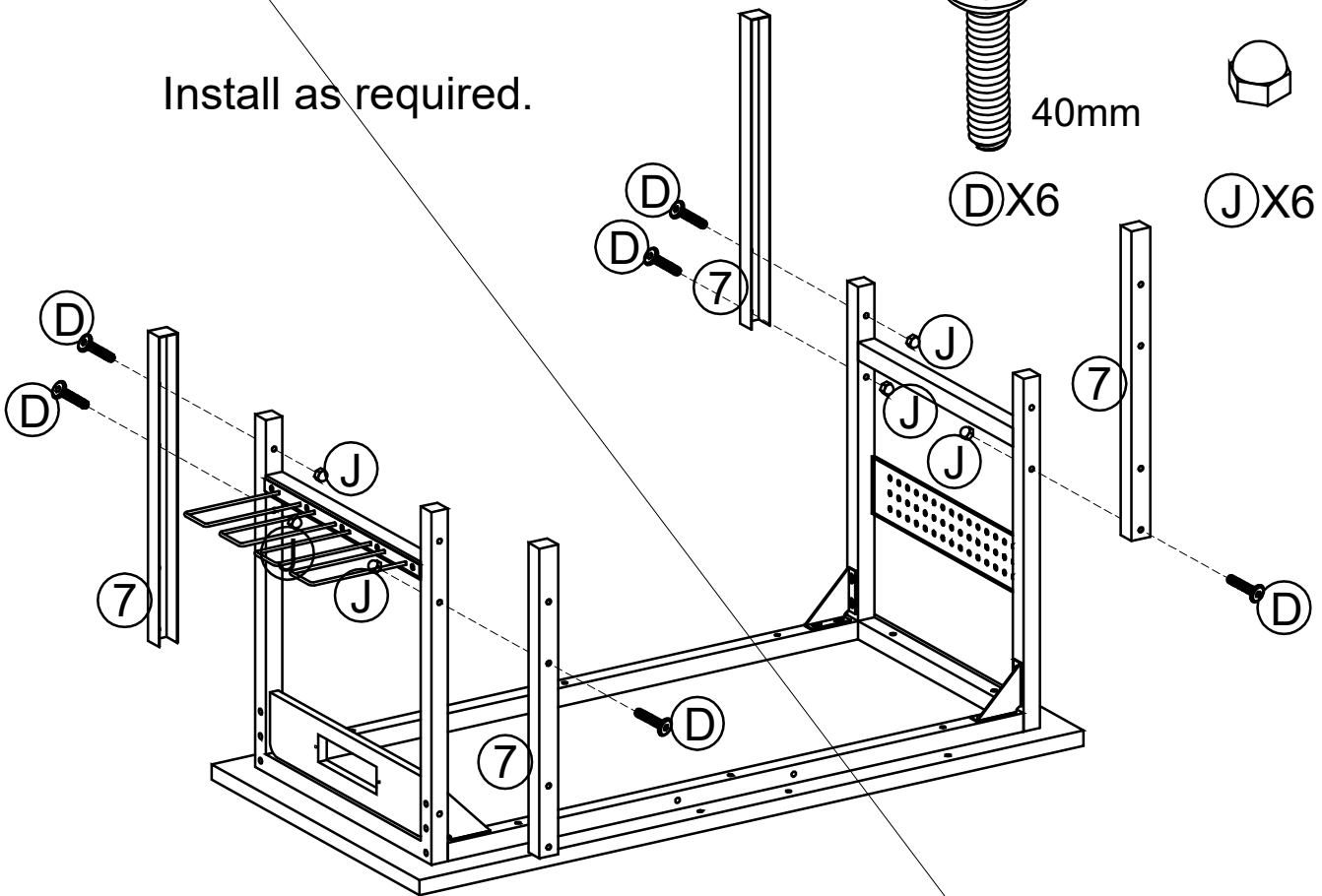

5

According to the actual situation,
L pieces move or K pieces fixed

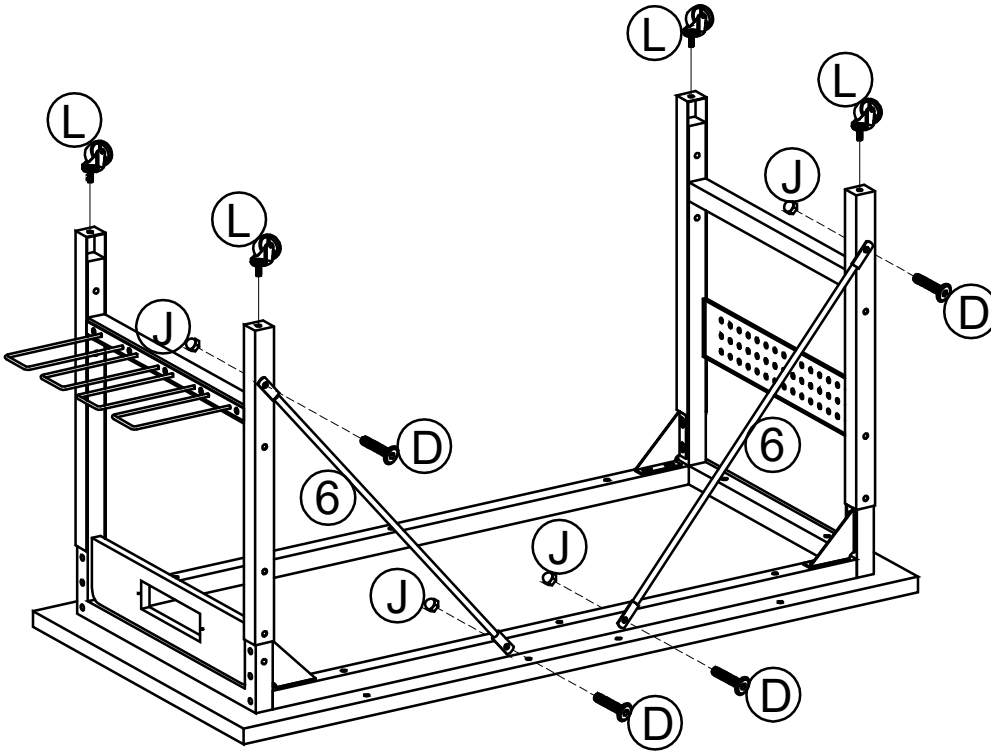
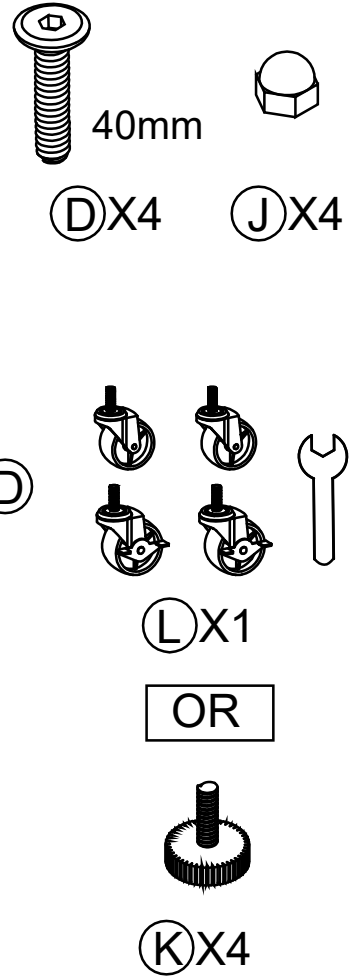

6

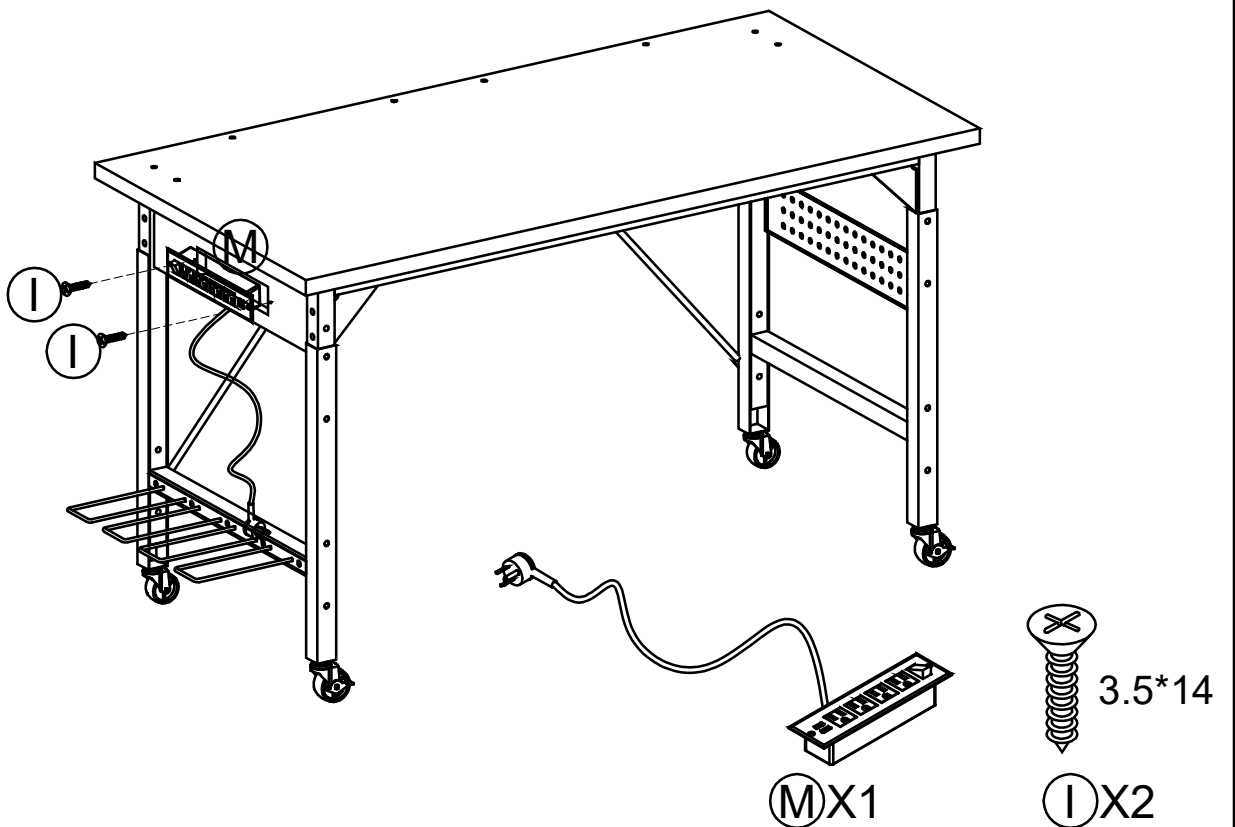

7

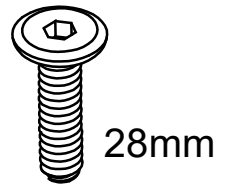
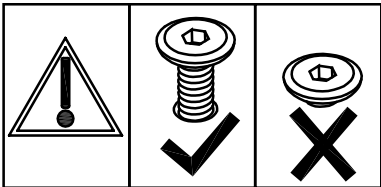
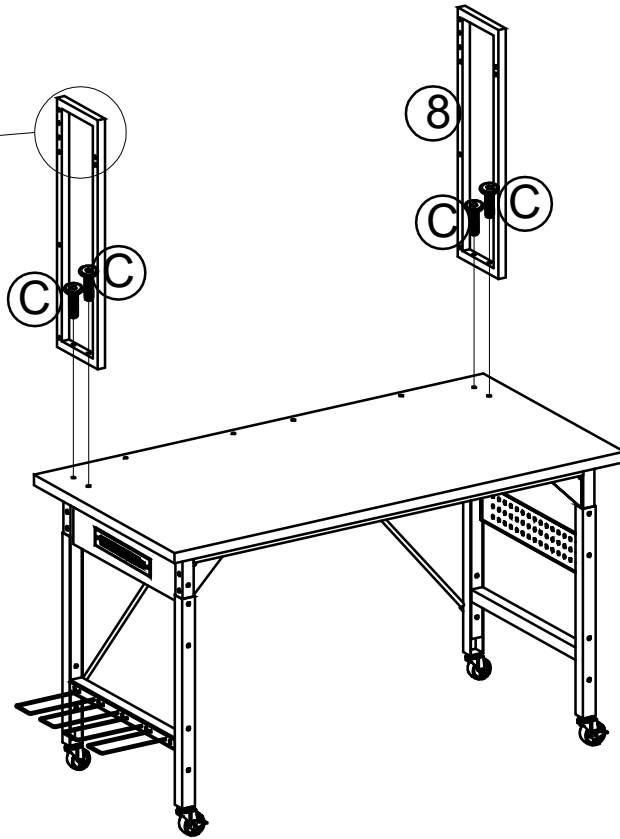
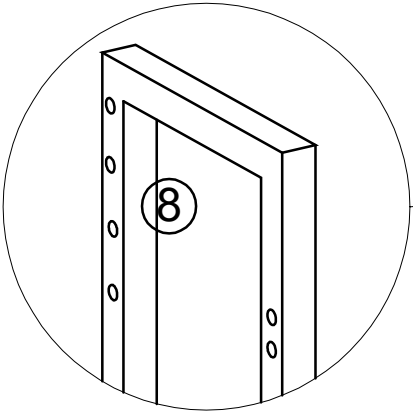

28mm

(C)X4

8

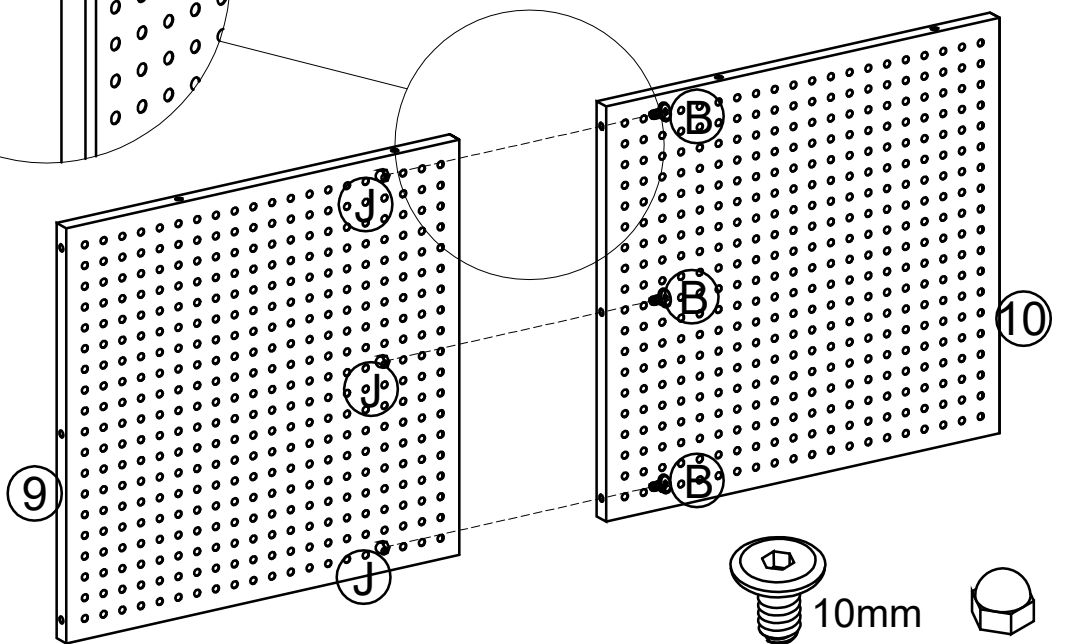
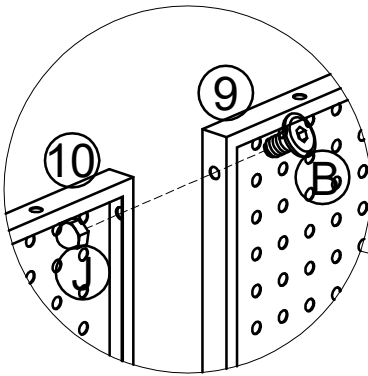

10mm



(B)X3

(J)X3

9

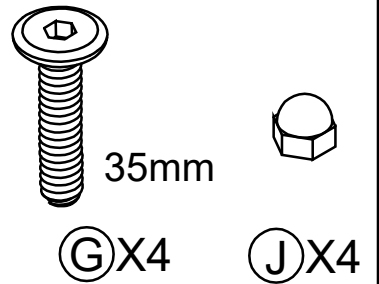
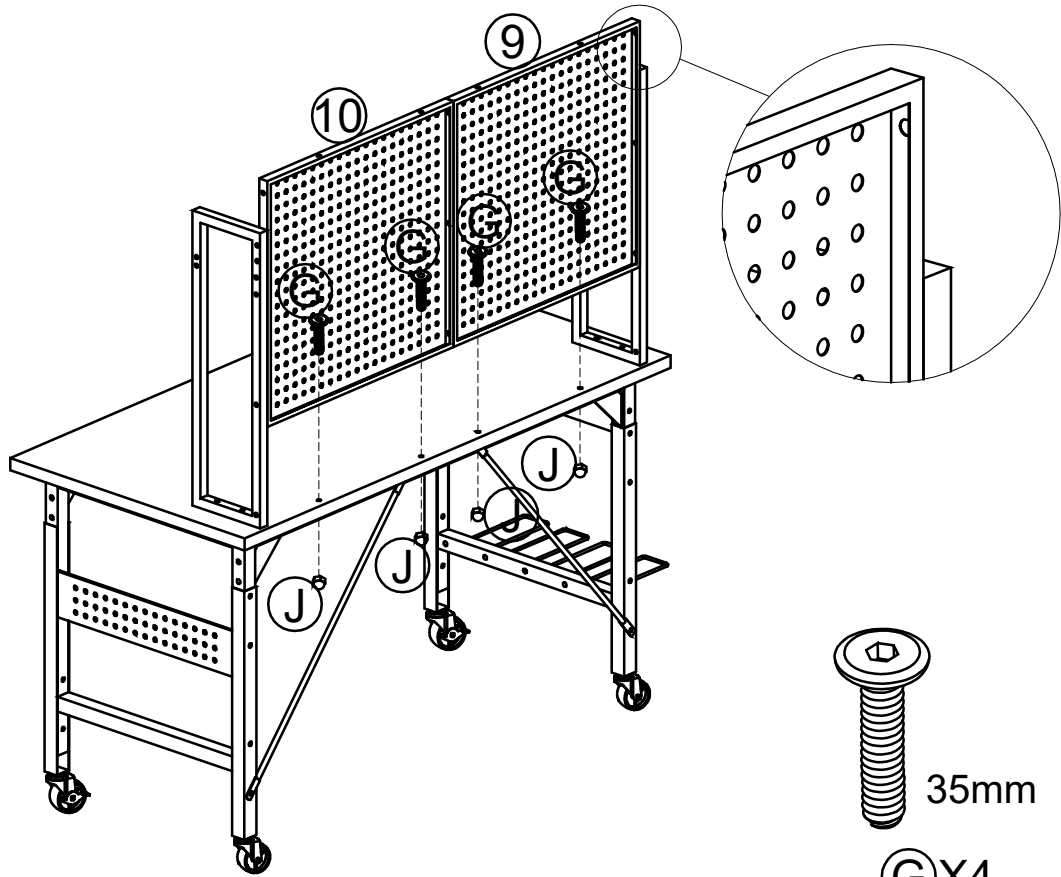

10

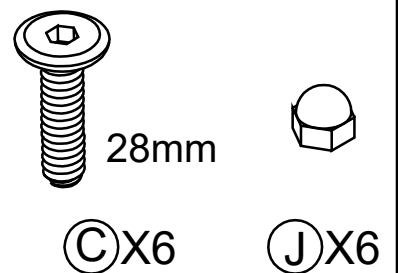
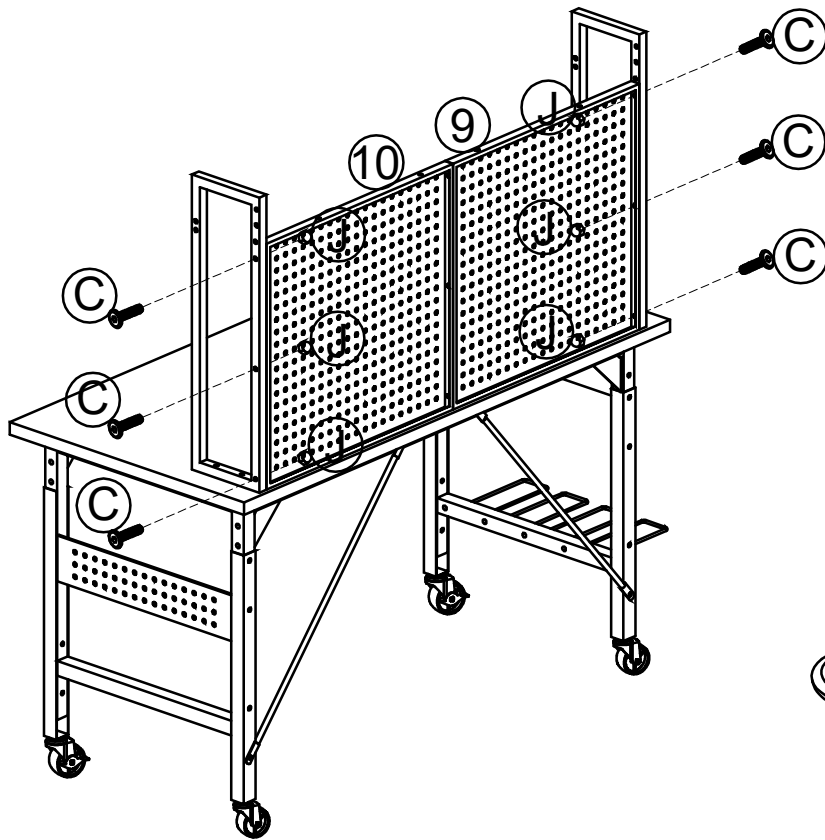

11

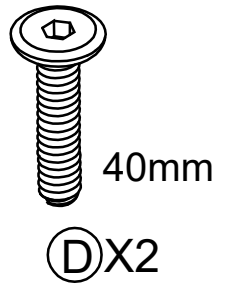
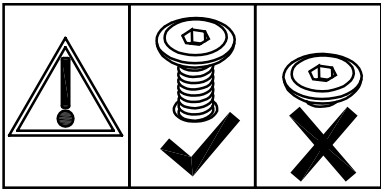
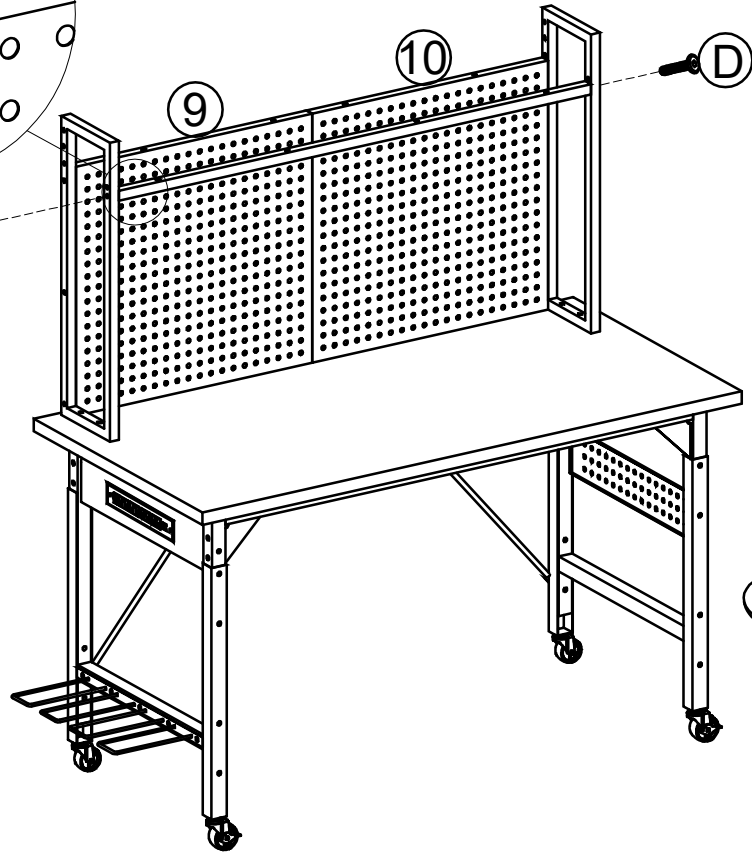
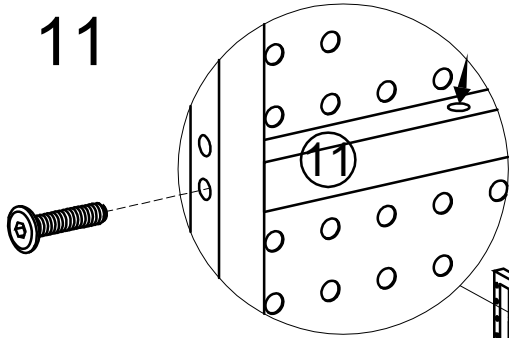

12

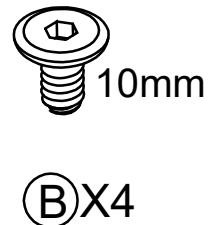
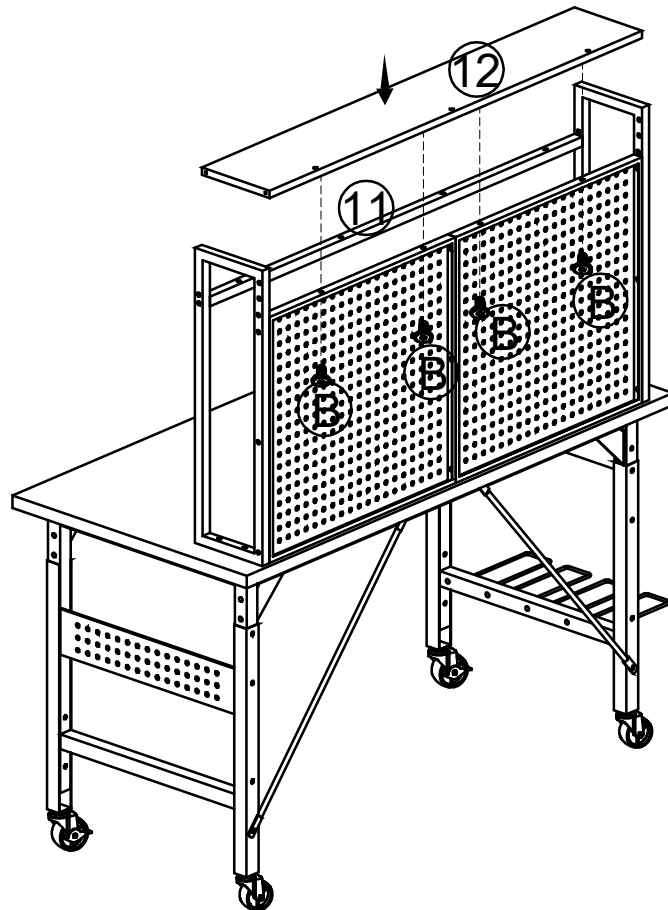

13

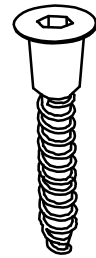
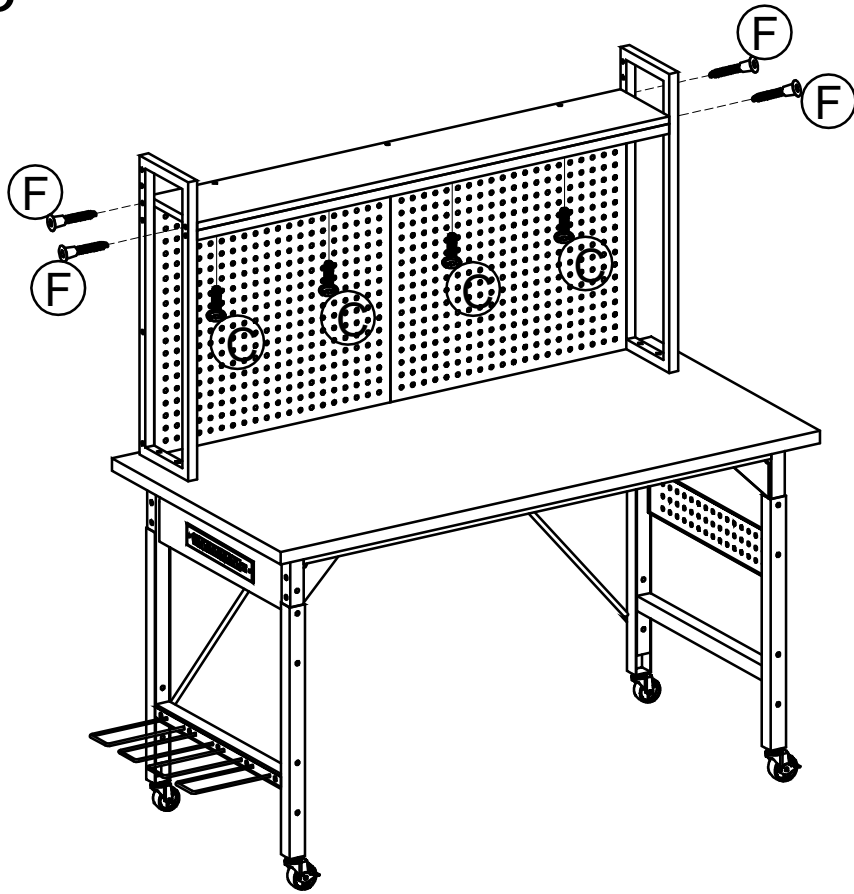

50mm

(F)X4

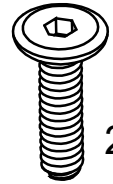

28mm

(C)X4

14

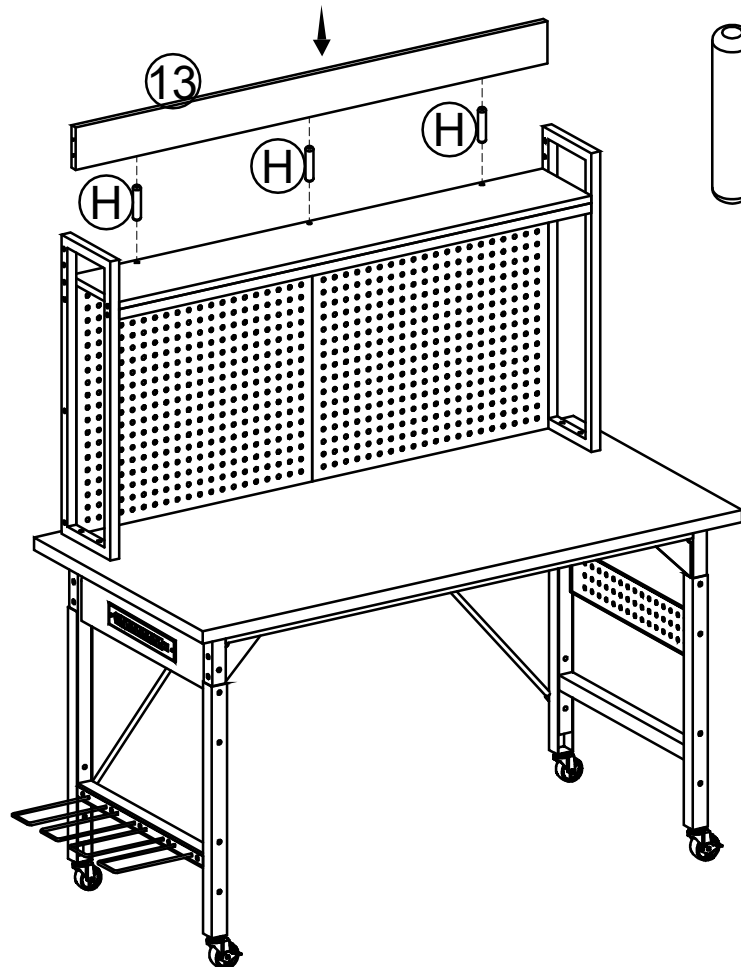

M8*30

(H)X3

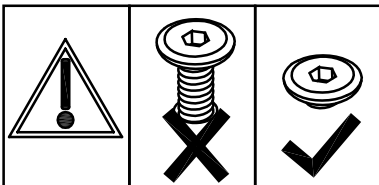

15

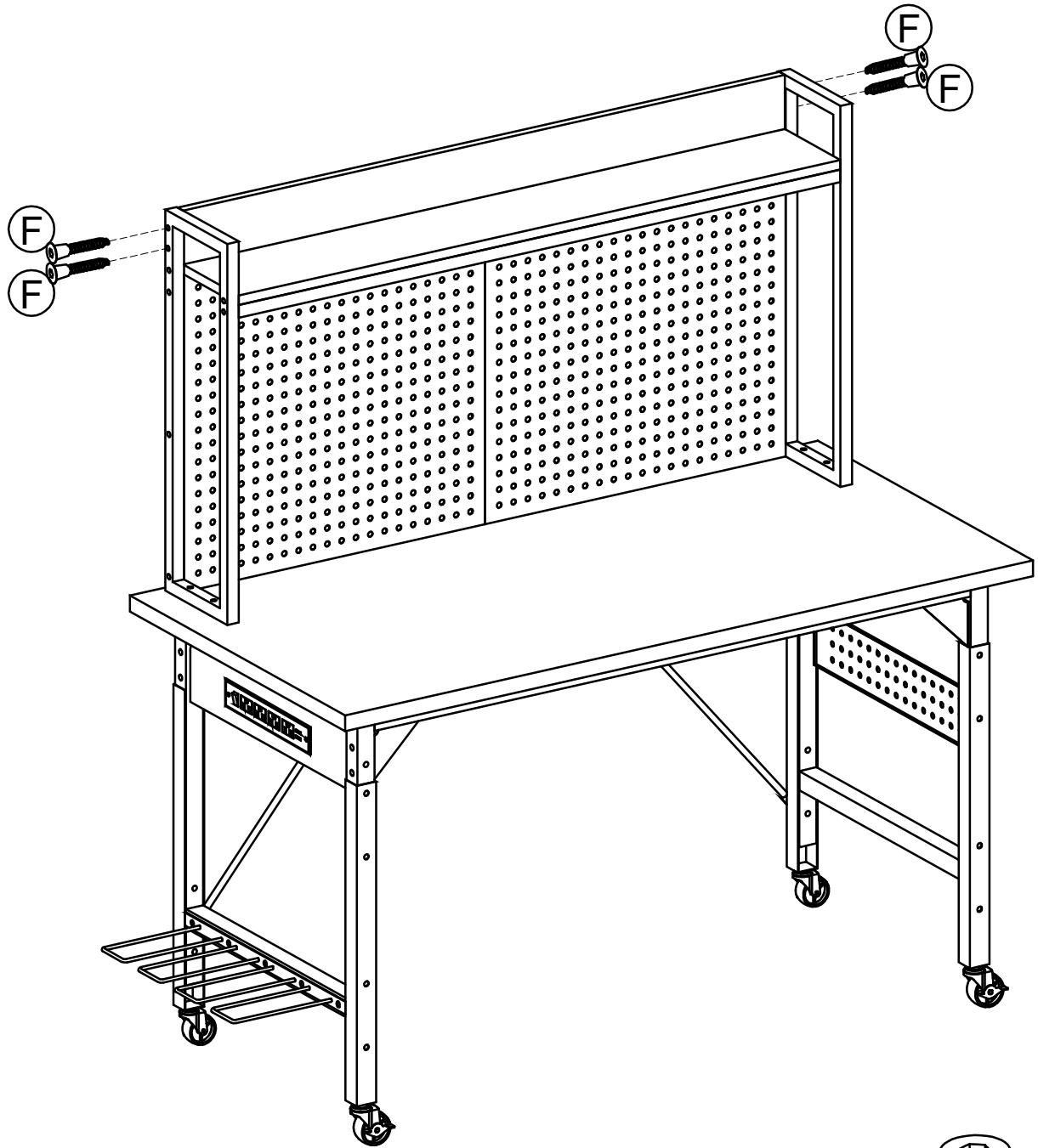

Tighten all screws !

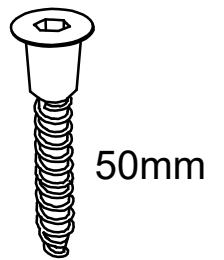

(F) X4

16

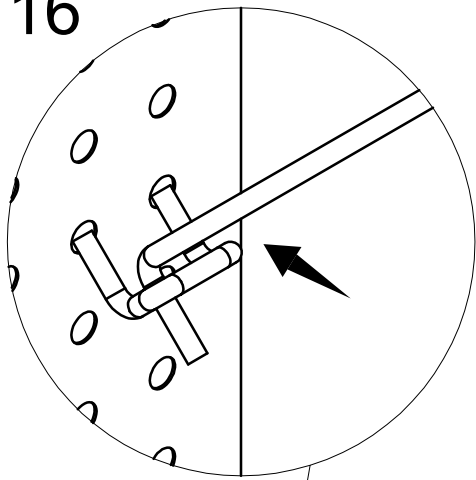

Sections 16, 17 and 18 each have a load-bearing capacity of approximately 1.5 kg.

