

Executive Desk

IMPORTANT

Carefully remove all the parts from the carton and place them individually on a soft cloth to prevent scratches or other damage.

Carefully and strictly follow these assembly instructions to ensure a completed product as designed.

Do not use power tools above 8 volts to assemble.

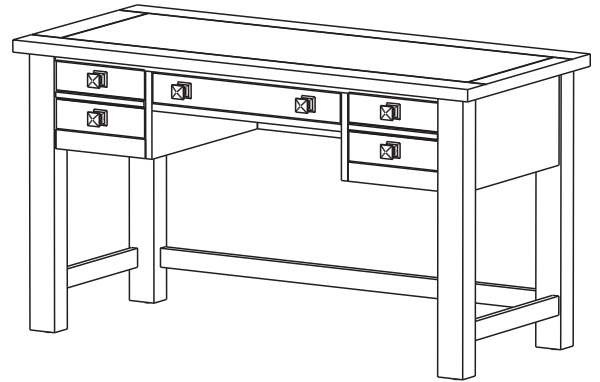

Part List

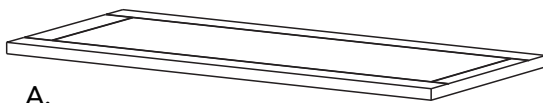

A.
Top
1 pc.

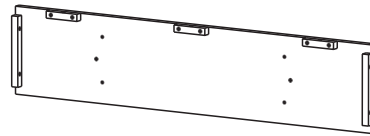

F.
Back Panel
1 pc.

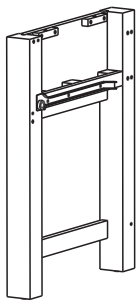

B.
Side Frame
1 pc.

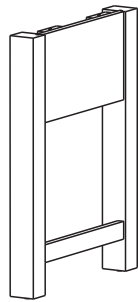

C.
Side Frame
1 pc.



G.
Back Rail
1 pc.



H.
Front Rail
1 pc.



I.
Front Rail
1 pc.



J.
Front Rail
2 pcs.



K
Drawer
2 pcs.

Refer to later page(s) of these instructions for drawer assembly.



D.
Middle Panel
1 pc.

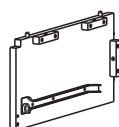

E.
Middle Panel
1 pc.



L
Keyboard Front
1 pc.

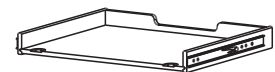

M.
Keyboard
1 pc.

Hardware List



Hex Wrench
1 pc.

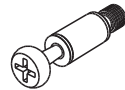

Cam Lock
8 pcs. (+1 extra)

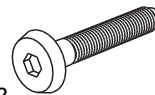

M6x32
Head Cap Bolt
17 pcs. (+1 extra)



Spring Washer
17 pcs. (+1 extra)



Flat Washer
17 pcs. (+1 extra)

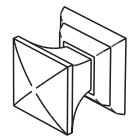

Knob
6 pcs.



Small Hex Wrench
1 pc.



Cam Lock Screw
8 pcs. (+2 extra)

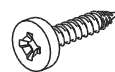

M3x15
Wood Screw
6 pcs. (+1 extra)

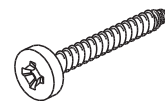

M4x38
Wood Screw (long)
2 pcs. (+1 extra)



M4x19
Machine Screw
8 pcs.

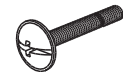

M4x25
Machine Screw (long)
4 pcs.

Tool(s) required for assembly: Phillips screwdriver, Level

Assembly Instructions 2/6

IMPORTANT

- Use a soft cloth between these parts and the floor.
- Do not use power tools above 8 volts to assemble.
- Do not tighten all the bolts until each part is properly assembled.
- The unit must be level to work properly. Use the included adjustable levelers to level.
- Keep Hex Wrench as the bolts may need to be tightened in the future.

STEP 1

Insert Cam Lock Screws into pre-drilled holes of Side Frames (B), (C) and Middle Panels (D), (E), then tighten. (See Figure 1)

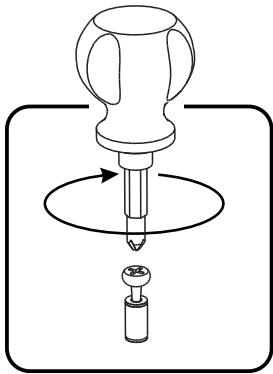
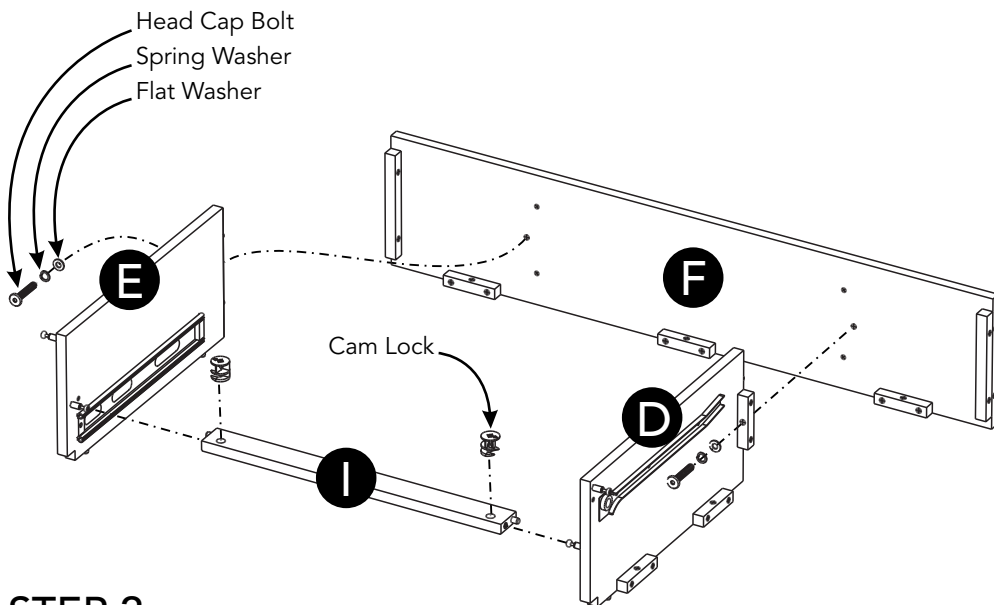
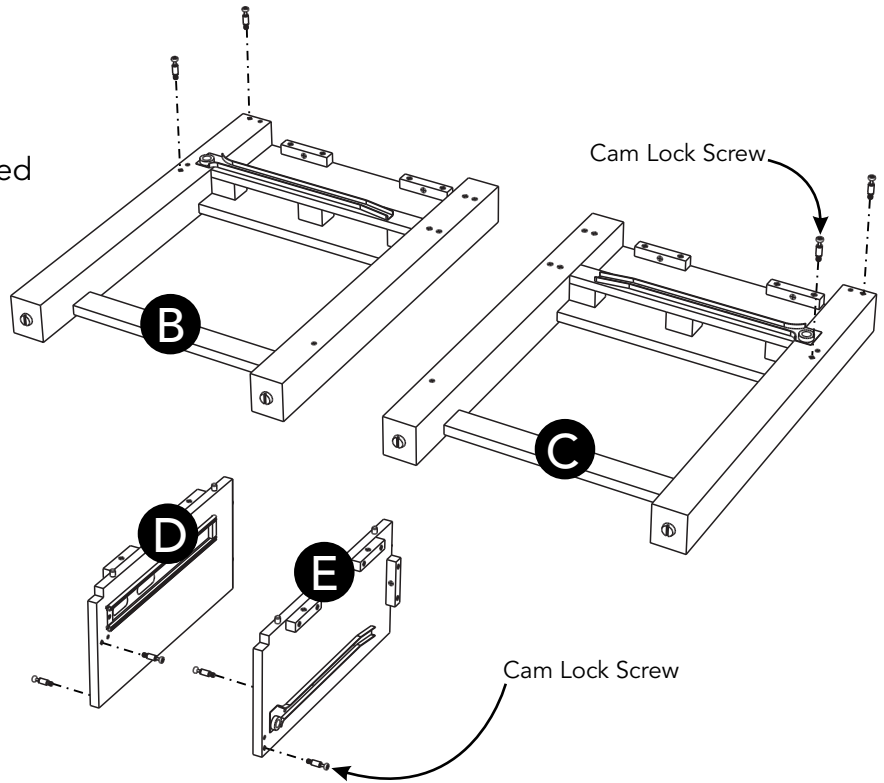

Figure 1



STEP 2

Attach Middle Panels (D) and (E) to Front Rail (I) with Cam Locks. (See Figure 2)

Attach unit to Back Panel (F) with Flat Washers, Spring Washers and Head Cap Bolts. (See Figure 3)

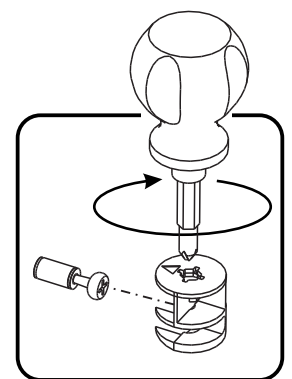

Figure 2

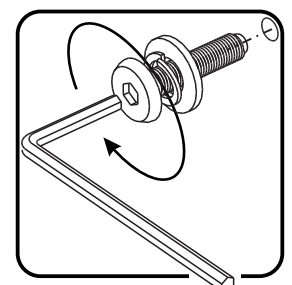

Figure 3

Assembly Instructions 3/6

STEP 3

Place Top (A) upside down on a soft cloth.

Attach unit and Front Rail (H) to Top (A) with Flat Washers, Spring Washers and Head Cap Bolts.

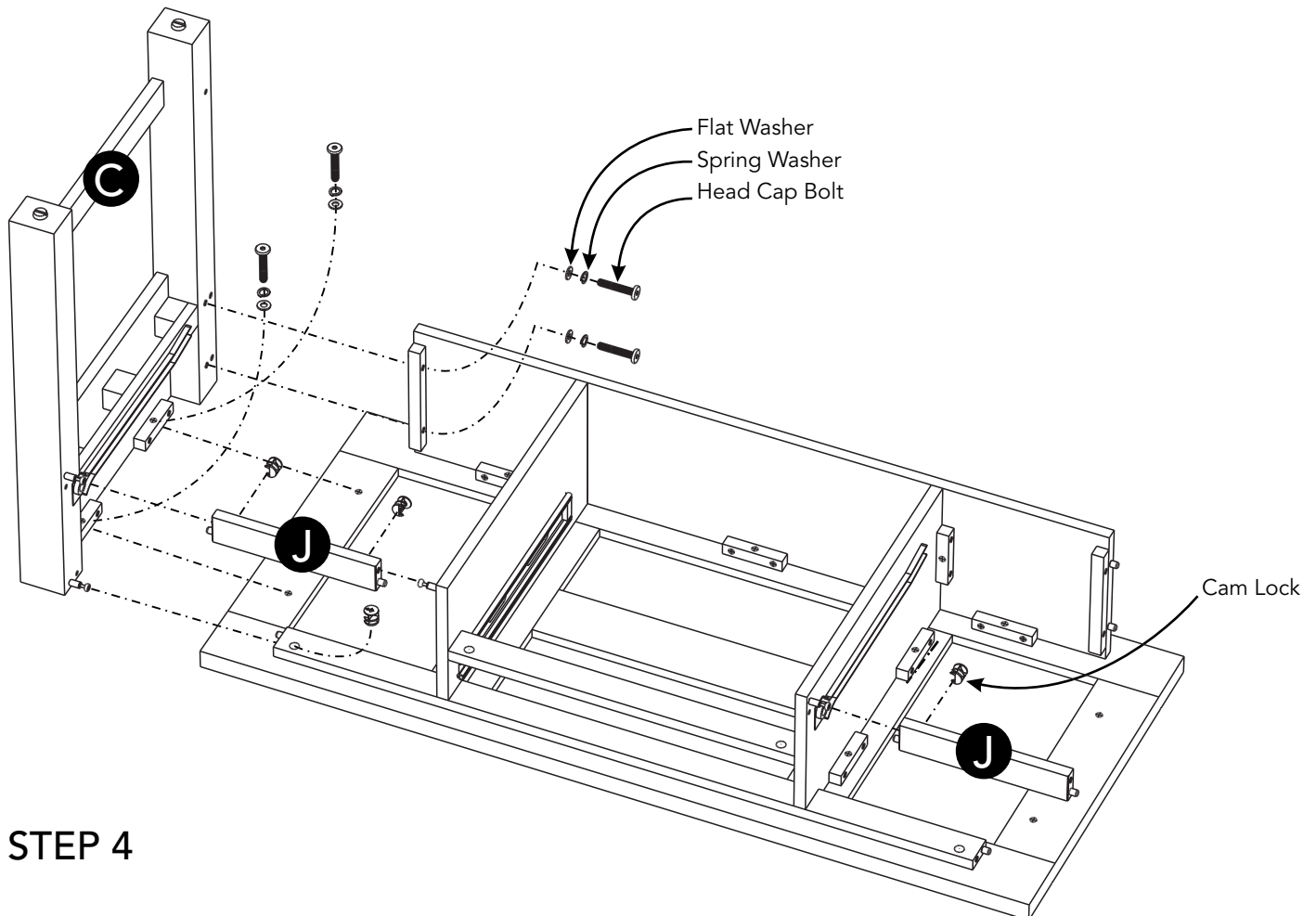
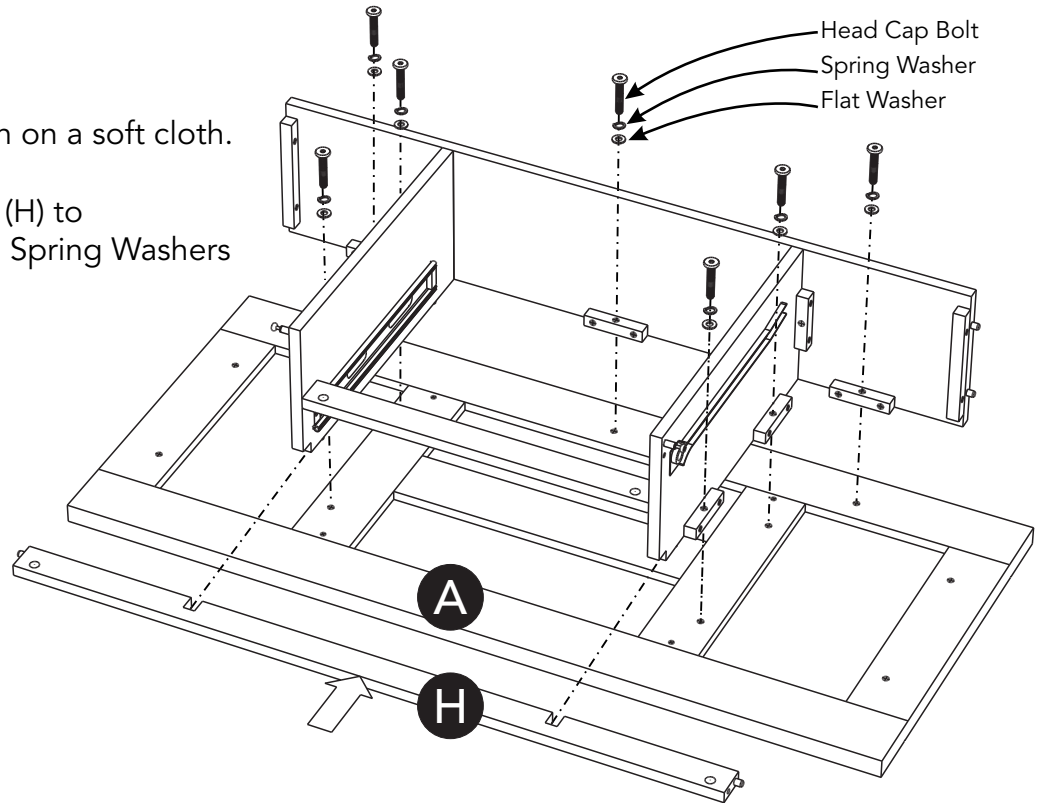

STEP 4

Attach Front Rails (J) to unit with Cam Locks.

Attach Side Frame (C) to unit with Cam Locks, Flat Washers, Spring Washers and Head Cap Bolts.

Assembly Instructions 4/6

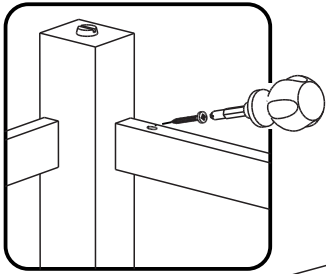
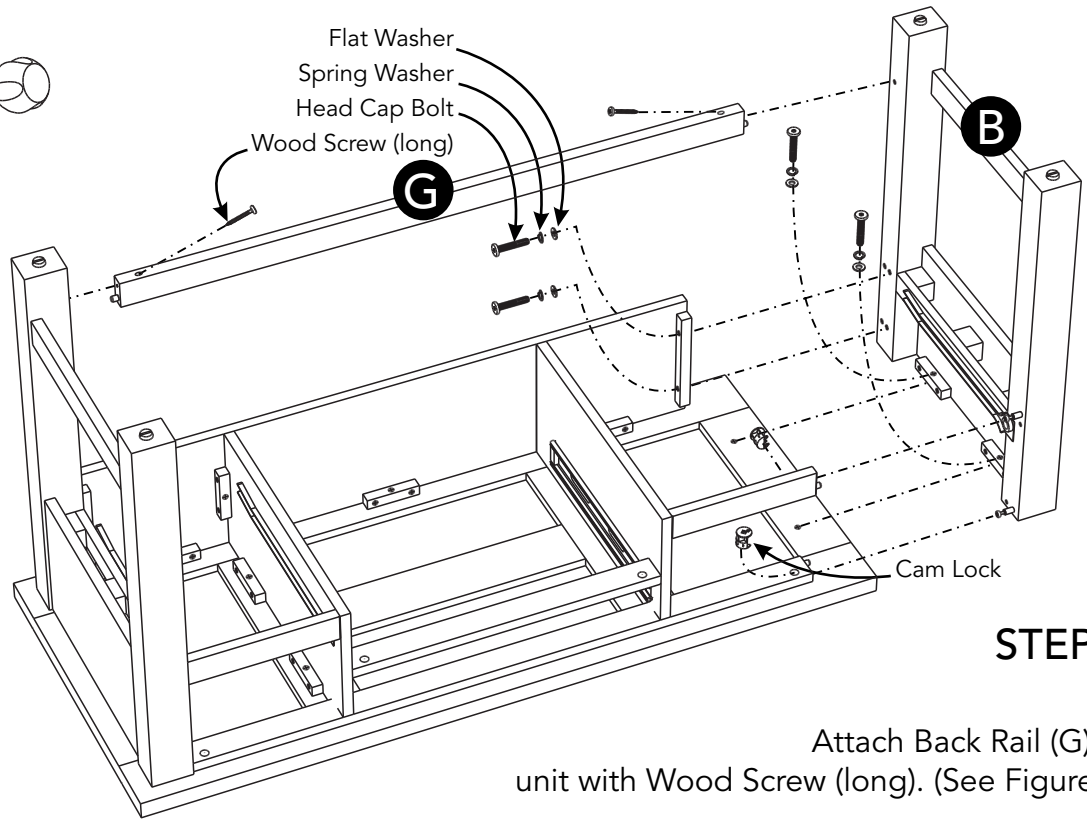

Figure 4



STEP 5

Attach Back Rail (G) to unit with Wood Screw (long). (See Figure 4)

Attach Side Frame (B) to unit with Flat Washers, Spring Washers, Head Cap Bolts, Cam Locks and Wood Screw (long).

STEP 6

Attach Keyboard Front (L) to Keyboard (M) with Wood Screws. (See Figure 5)

Attach Knobs to Keyboard Front (L) with Machine Screws (long). (See Figure 6)

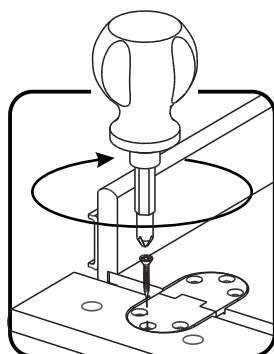
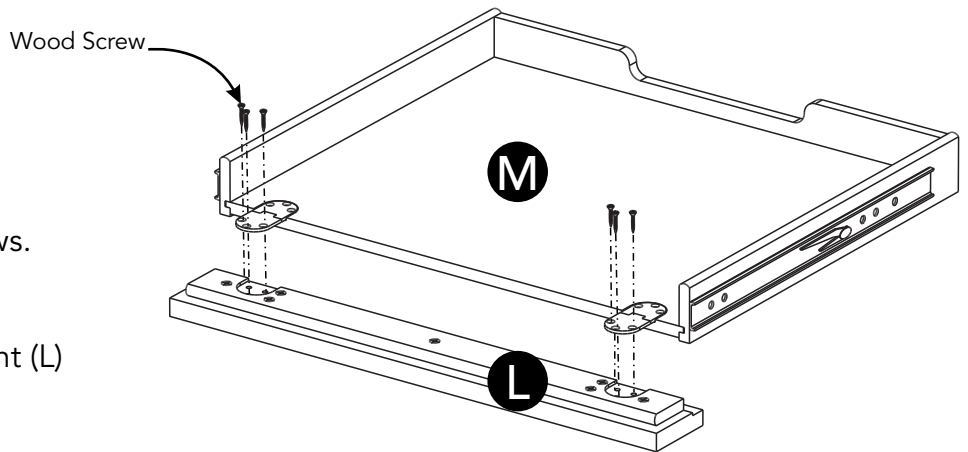

Figure 5

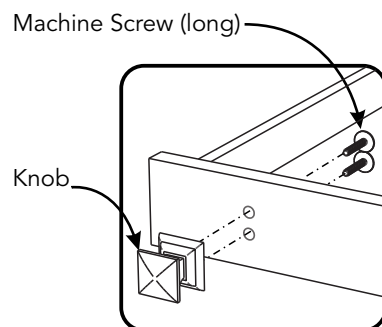
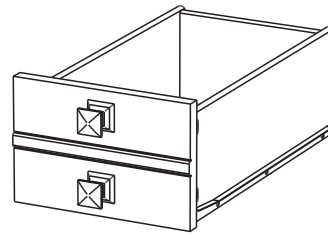
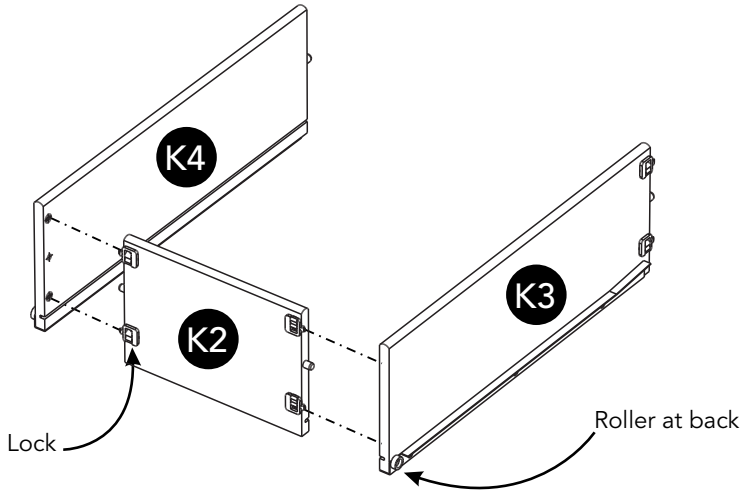

Figure 6

Assembly Instructions 5/6

Drawer (K)



STEP 7

Attach Drawer Sides (K3) and (K4) to Drawer Back (K2), then flip Locks. (See Figures 7 and 8)

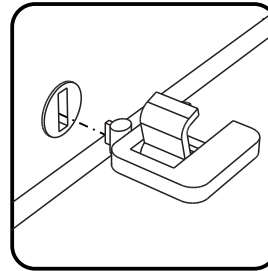

Figure 7

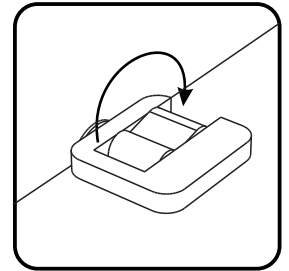
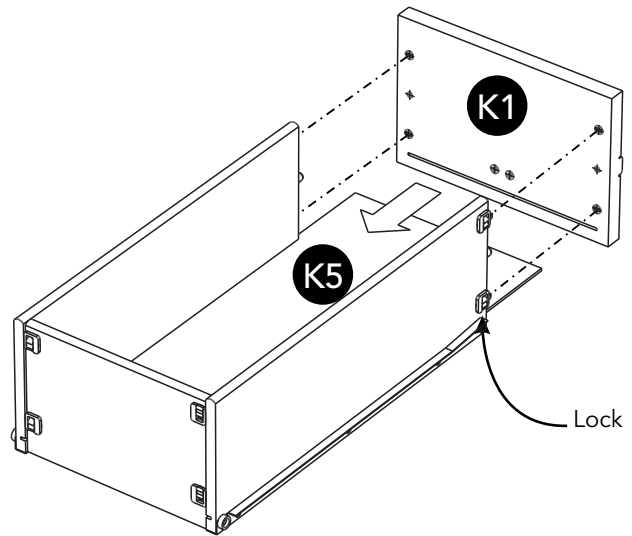
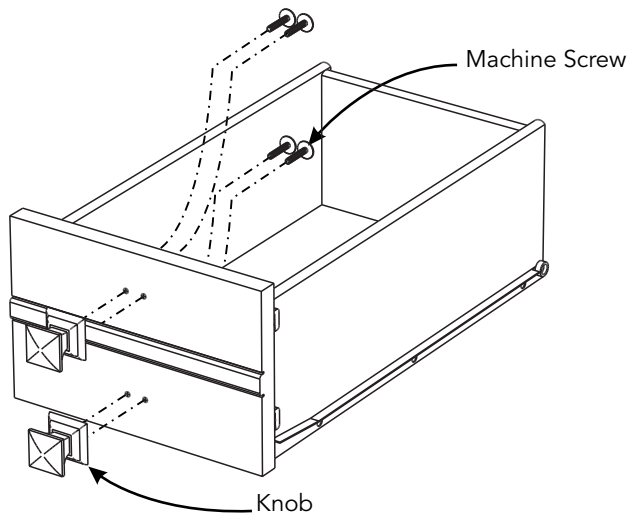

Figure 8

STEP 8

Slide Drawer Bottom (K5) into groove.

Attach Drawer Front (K1) to unit, then flip Locks.



STEP 9

Attach Knobs with Machine Screws.

Part List

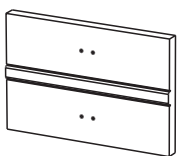

K1.
Drawer Front
2 pcs.



K2.
Drawer Back
2 pcs.

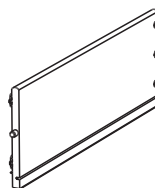

K3.
Drawer Side
2 pcs.

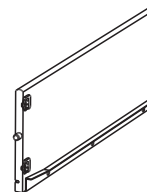

K4.
Drawer Side
2 pcs.

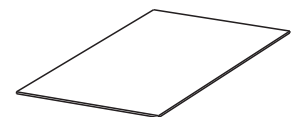

K5.
Drawer Bottom
2 pcs.

STEP 10

Turn unit from Step 5 over to its upright position.

Slide Drawers (K) and keyboard into position.

Note: To remove keyboard in future, push plastic lever on left side up, push plastic lever on right side down and pull open. (See Figures 9 and 10)

Level unit by adjusting the adjustable levelers on bottom of unit. (See Figure 11)

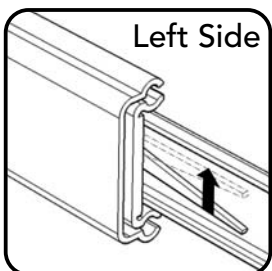
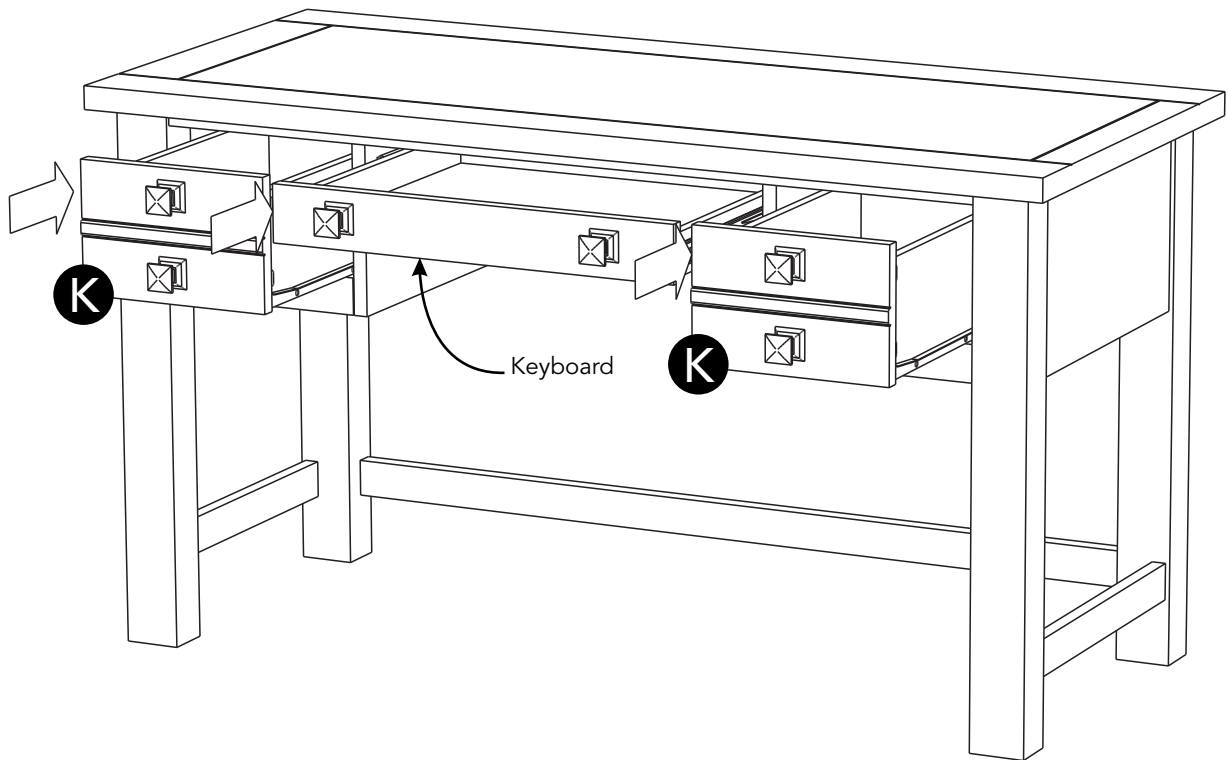

Figure 9

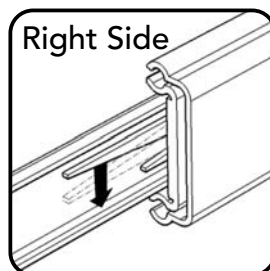

Figure 10

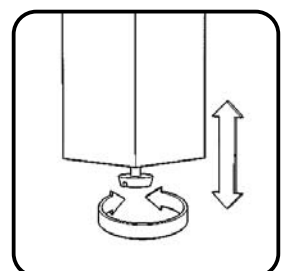

Figure 11

CARE INSTRUCTIONS

NEVER

allow liquids to remain on furniture.
Absorption causes parts to warp
and split and finishes to delaminate.

NEVER

use glass cleaners on
finished furniture. Ammonia
chemically attacks the finish.



Do not use power tools
above 8 volts to assemble.

**PREVENT
CRACKING**

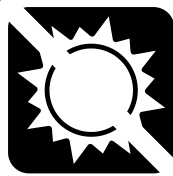

Do not place
in direct sunlight.

**PREVENT
FADING**



Do not write
directly on surface.

**PREVENT
MARKING**



Do not place hot
objects on surface.

**PREVENT
FINISH DAMAGE**

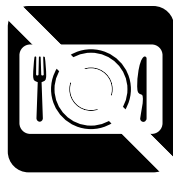

Do not use rubber
based placemats.

**PREVENT
DISCOLORING**



Do not use commercial
waxes and polishes.

**PREVENT
YELLOWING**

CLEAN

with a soft cloth moistened
in lukewarm soap and water.
Buff with a dry clean cloth.



We will provide replacements free of charge for missing or damaged parts within 30 days of purchase. Digital images of the defective parts may be required. If the product was not purchased from an authorized retailer, we are under no obligation to provide replacement parts. Parts are not available for fully assembled items, nor are parts available for sale. Replacements for missing or damaged parts may be requested.