

# Installation Manual



## Horizontal Storage Shed

Thanks to choose our product. Missing parts, Quality, Installation Questions, please contact with us.

Model : CWX120A

---

## Tools you need:

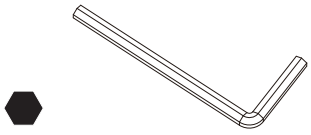

Hex wrench  
(included in the box)

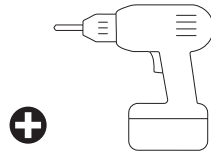

Electric drill  
(Not included in the accessory pack)

---

## Notes:

1. Before you start, separate and identify all the parts and plates to be sure that you have all the necessary parts for your building (refer to the Components List Page).
2. Finding a necessary area to assemble the storage shed, make sure the floor is flat.
3. Reviewing all instructions and the appropriate information before you begin, make sure following the step sequence carefully for successful results.
4. Following the steps to open the parts' bags and do not open all the bags in one time in case of mixture of parts.
5. The company will not be responsible for any losses caused by parts' damage due to incorrect installation methods, and the customer shall bear the responsibility on their own.

---

## Position of codes on plates:

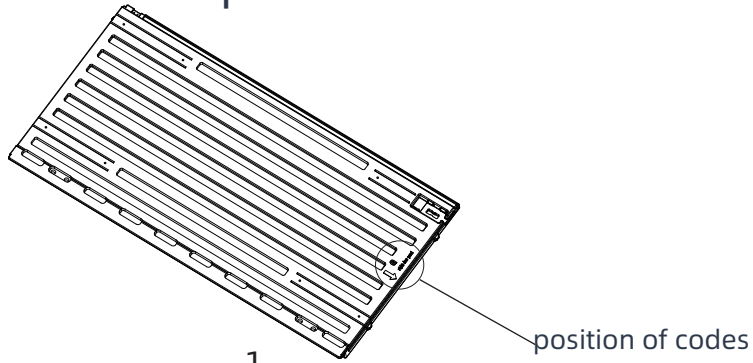

---

## Sizes:

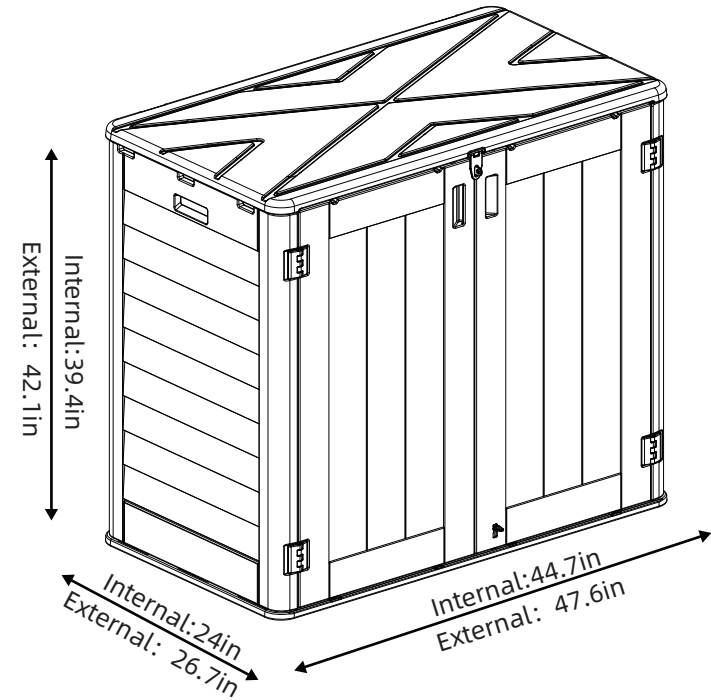

## Area of installation requirement

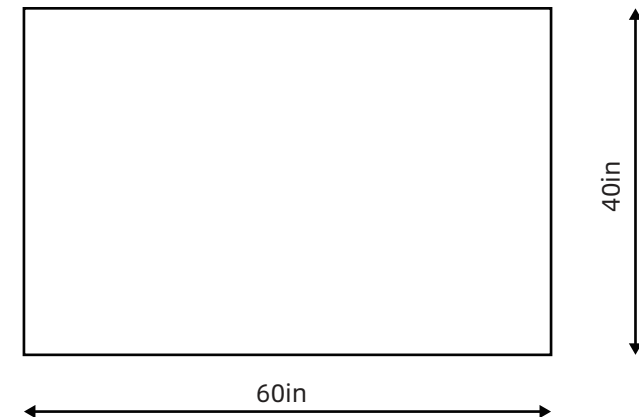

# Components List-A

Code	Photo	Qty	Position Of Package	Code	Photo	Qty	Position Of Package
A		1	Carton No.A	M		6	A-1
B		1	Carton No.A	N		12	A-1
C		1	Carton No.A	O		24	A-1
D		1	Carton No.A	P		9	A-2
E		1	Carton No.A	Q		1	A-2
F		1	Carton No.A	R		1	A-3
G		1	Carton No.A	S		3	A-3
H		1	Carton No.A	T		1	A-6
I		1	A-5	U		1	A-6
J		1	A-4	S		4	A-6
K		1	A-4	Backup		1	
L		1	A-5				

## PRODUCT ASSEMBLY

Top1

MIDDLE&UNDER

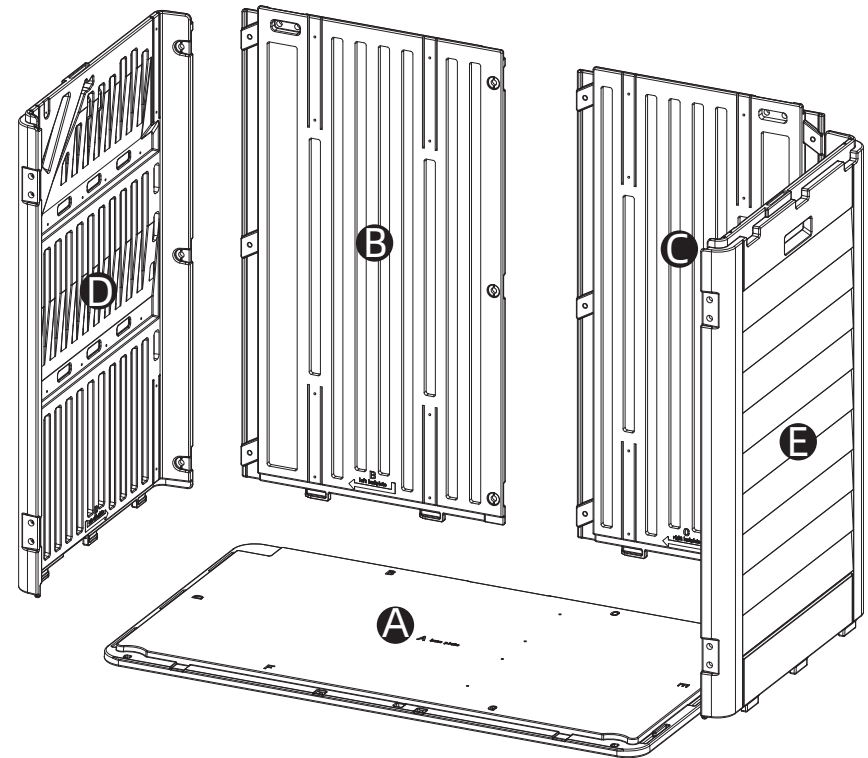
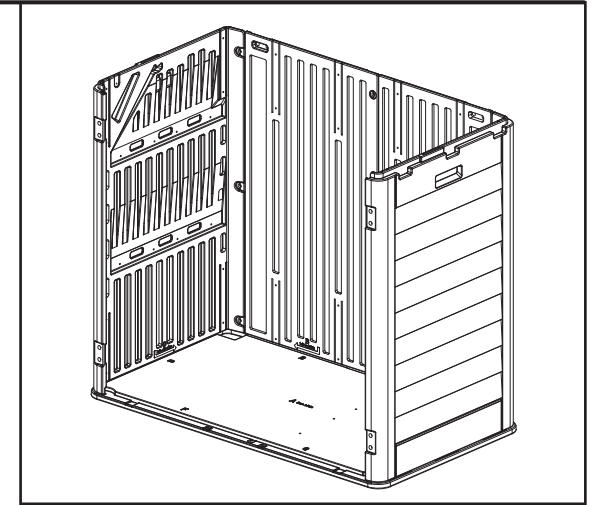

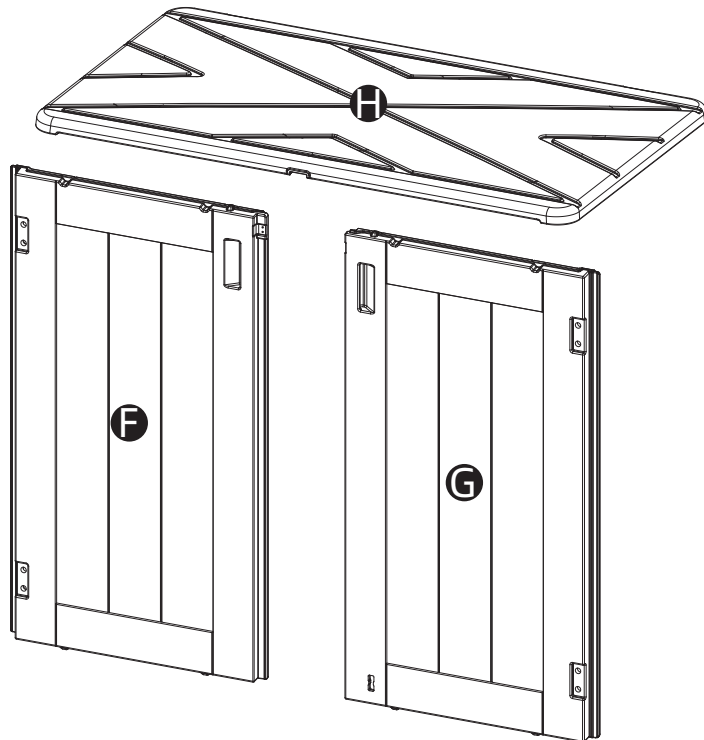
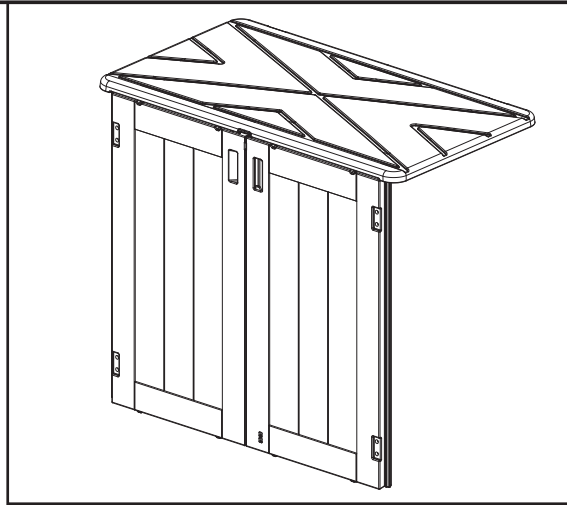

Top2

FRONT&UPPER



STEP1

BACK PLATE ASSEMBLY

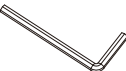
B		x1	Carton No.A	C		x1	Carton No.A
P		x3	A-2	Q		x1	A-2

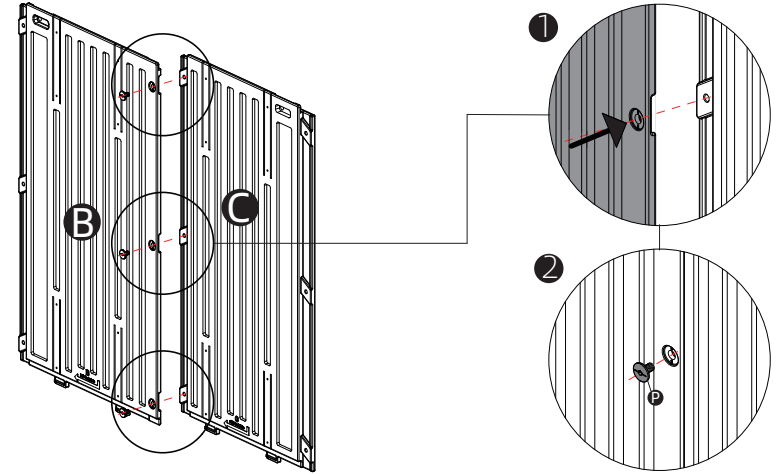

STEP2

BOTTOM PLATE ASSEMBLY

A		x1	Carton No.A				
---	---	----	-------------	--	--	--	--

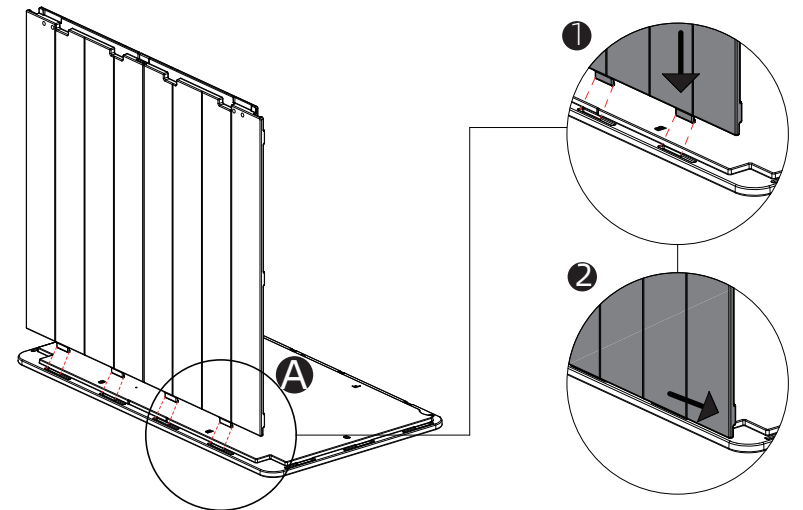

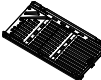

PRODUCT ASSEMBLY

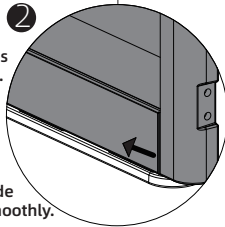
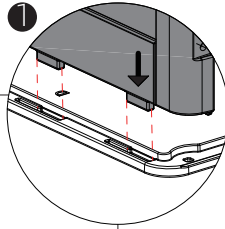
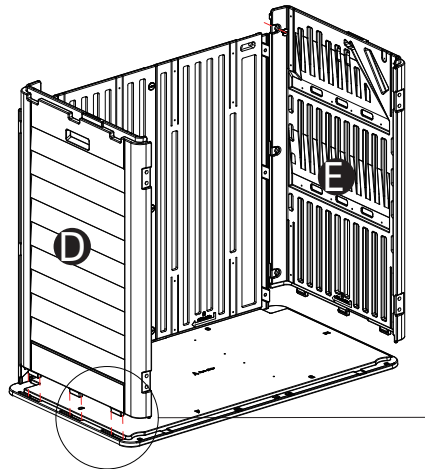
<b>STEP3</b>	D		x1	Carton No.A	E		x1	Carton No.A
SIDE PLATES ASSEMBLY								





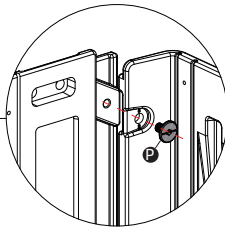
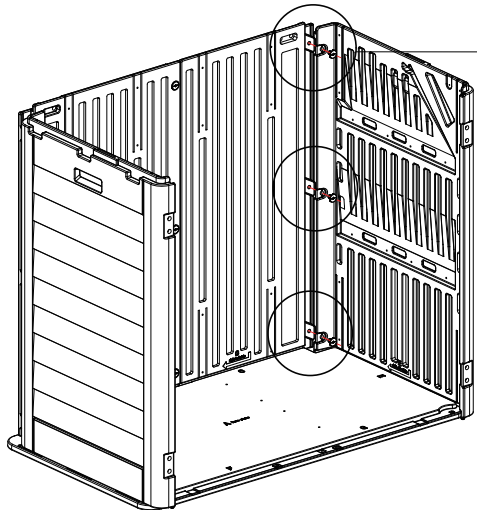

Note: Insert the side plates into the bottom first. Secondly push the side plates in the direction of arrow. Ensure that the plates are tilted 10 degrees to the outside to pass the bump smoothly.

<b>STEP4</b>	P		x6	A-2	Q		x1	A-2
SIDE PLATES FIXATION								

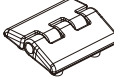
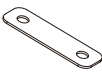

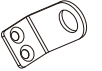
PRODUCT ASSEMBLY

<b>STEP5</b>	F		x1	Carton No.A	M		x2	A-1
PARTS ASSEMBLY FOR LEFT FRONT PLATE	N		x2	A-1	O		x4	A-1
	T		x1	A-6	S		x2	A-6

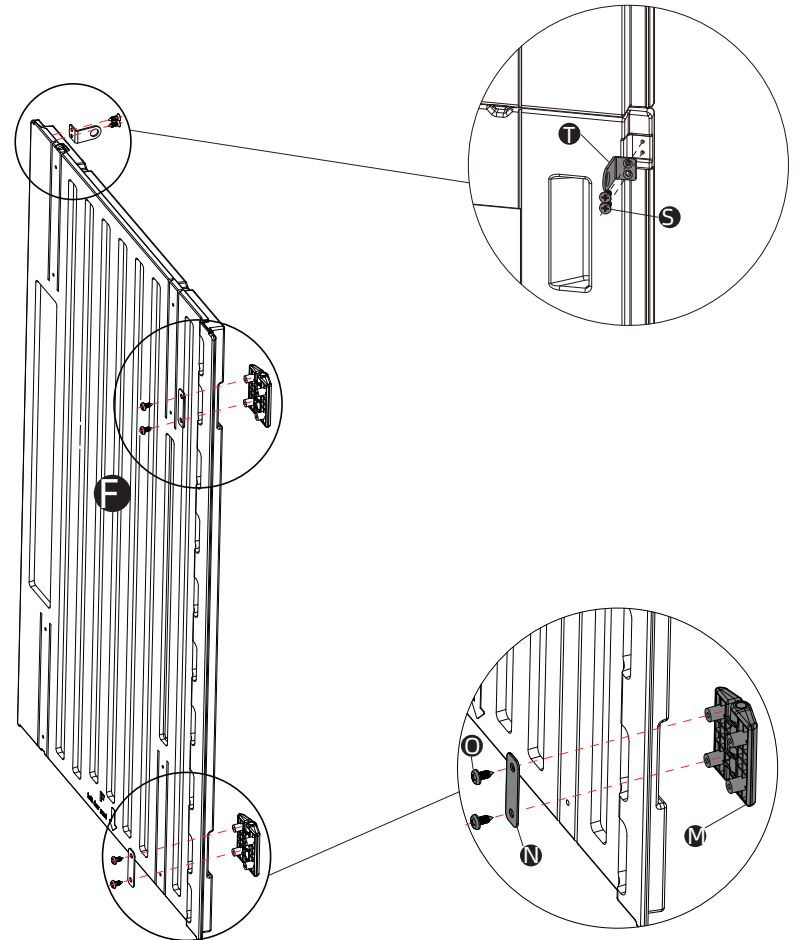

PRODUCT ASSEMBLY

STEP6		PARTS ASSEMBLY FOR RIGHT FRONT PLATE						
G		x1	Carton No.A	M		x2	A-1	
N		x2	A-1	O		x4	A-1	
U		x1	A-6	S		x2	A-6	
J		x1	A-4	K		x1	A-4	

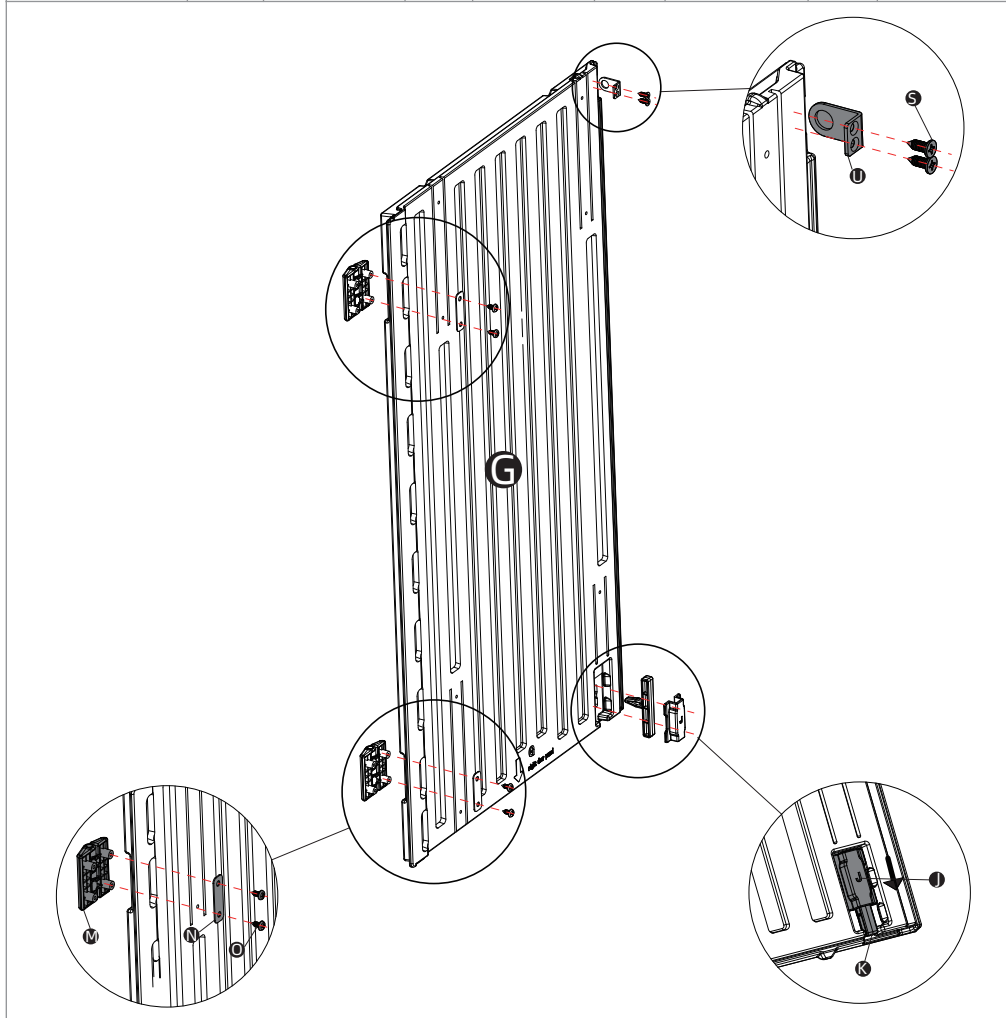

PRODUCT ASSEMBLY

STEP7		FRONT PLATES ASSEMBLY						
N		x4	A-1	O		x8	A-1	

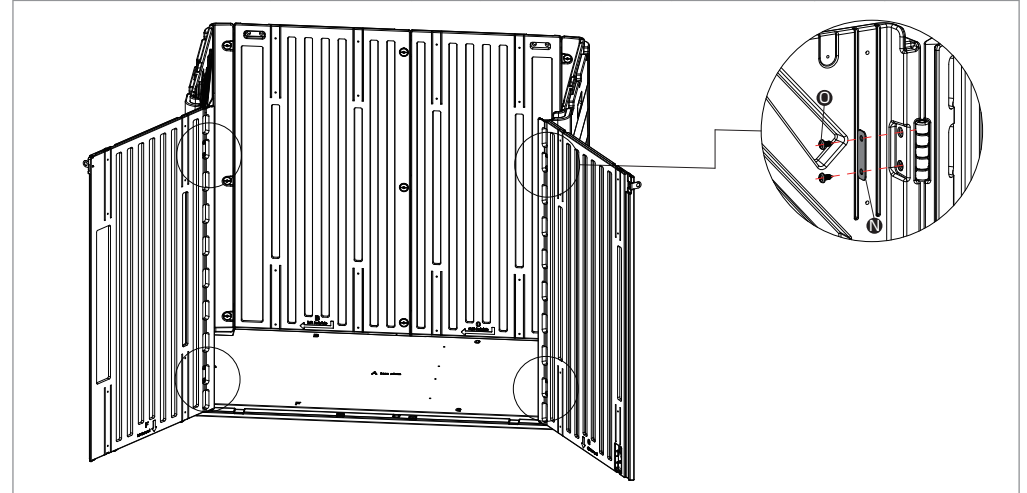



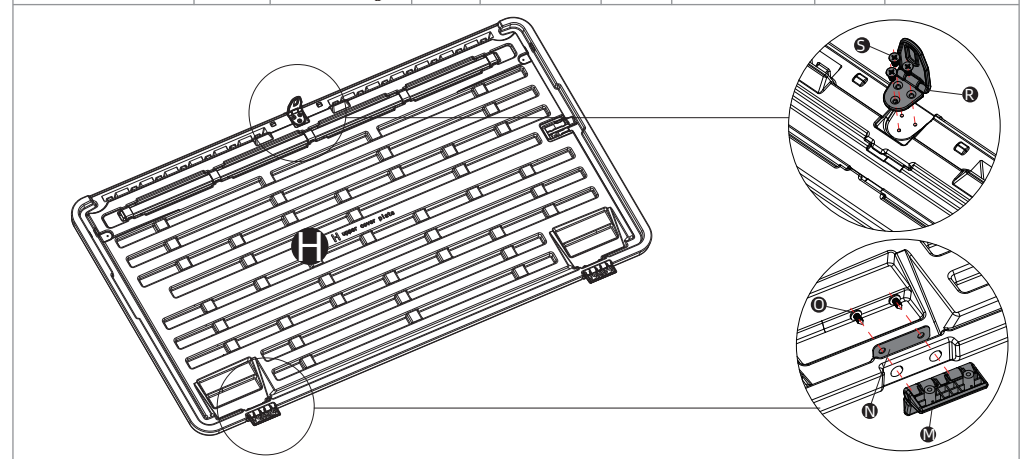

STEP8		PARTS ASSEMBLY FOR UPPER PLATES						
H		x1	Carton No.A	M		x2	A-1	
N		x2	A-1	O		x4	A-1	
R		x1	A-3	S		x3	A-3	



PRODUCT ASSEMBLY

STEP 9

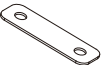
UPPER PLATES  
& ARM SUPPORT  
ASSEMBLY

L		x1	A-5	I		x1	A-5
N		x2	A-1	O		x4	A-1

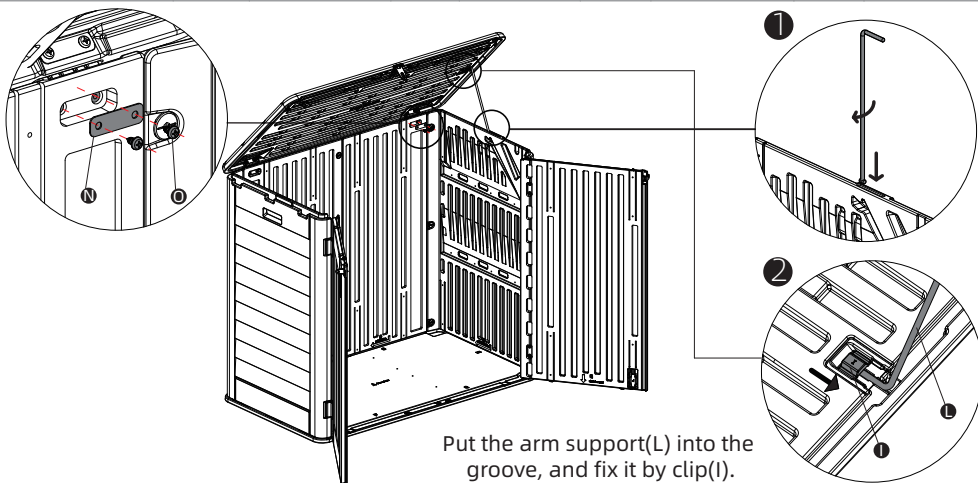

**Congratulations! You have completed the installation of the storage shed.**



PRODUCT USAGE STATUS

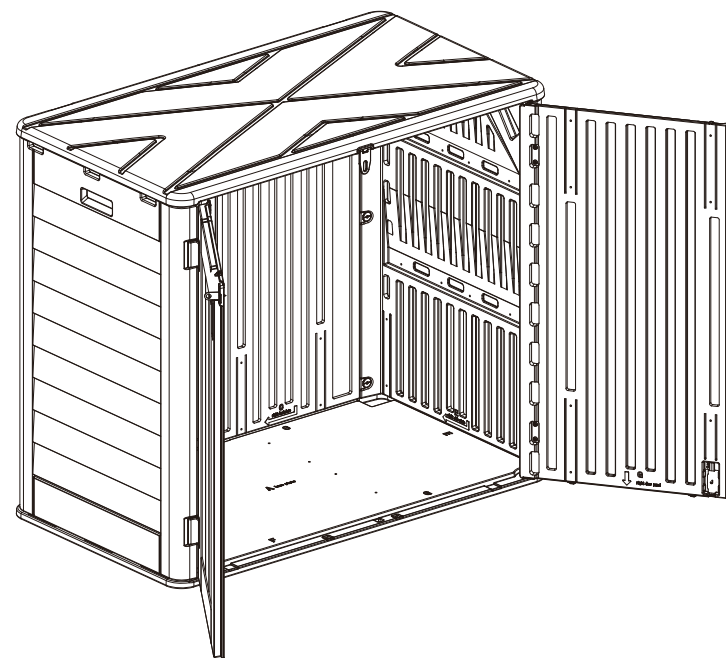
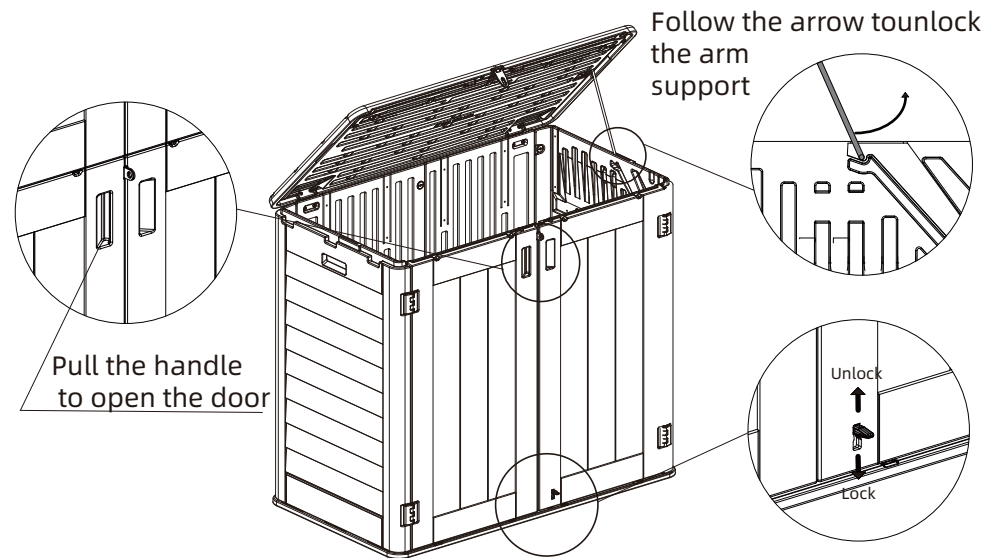

You can purchase extra parts in carton B to get horizontal storage shed if you need

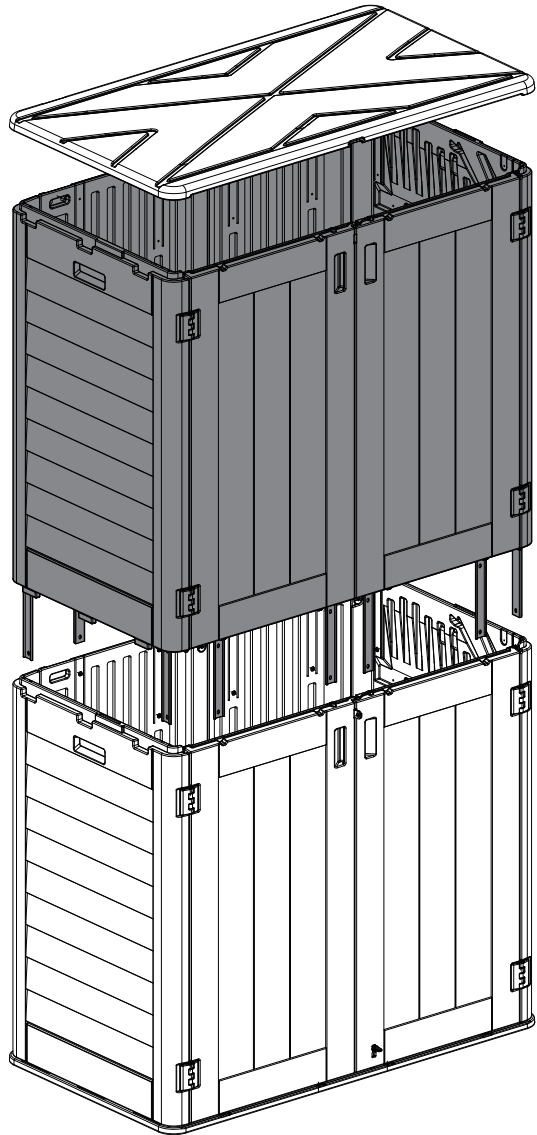

You can purchase metal shelves separately if you need.

Metal Shelves Kit For Horizontal Storage Shed

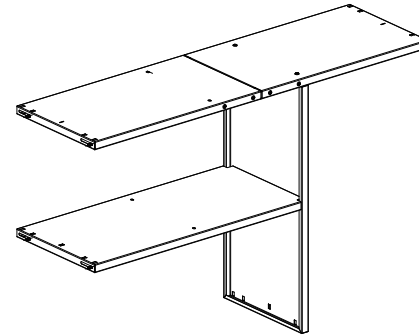

Display of finished assembly

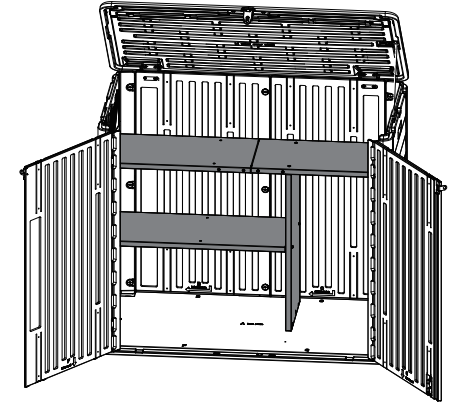

Metal Shelves Kit For Vertical Storage Shed

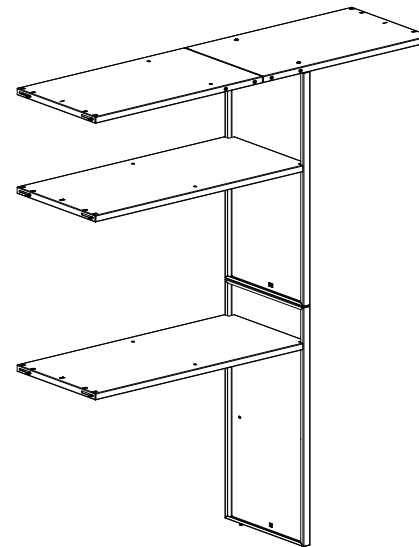

Display of finished assembly

